

DO NOT
SCALE FROM
THIS PRINT

**DESIGNED & DIMENSIONED
IN INCHES[MILLIMETERS]**
ALL DIMENSIONS REFERENCE EXCEPT AS SHOWN

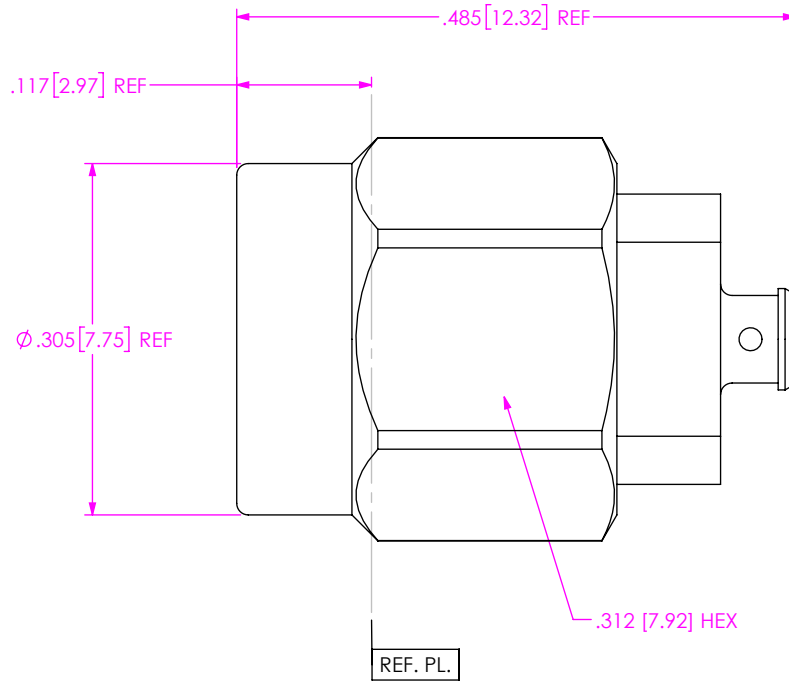

PRF01-P-C-XX-047A-SD

SERIES
-01: SMA

GENDER
-P: PLUG

TYPE
-C: CABLE

FINISH
-EG: 50µ" EXTRA HEAVY GOLD
CENTER CONTACT, 10µ" GOLD
OUTER CONTACT

TERMINATION
-D: DIRECT SOLDER

ORIENTATION
-S: STRAIGHT

CABLE TYPE
-047A: CCA-047-PFA

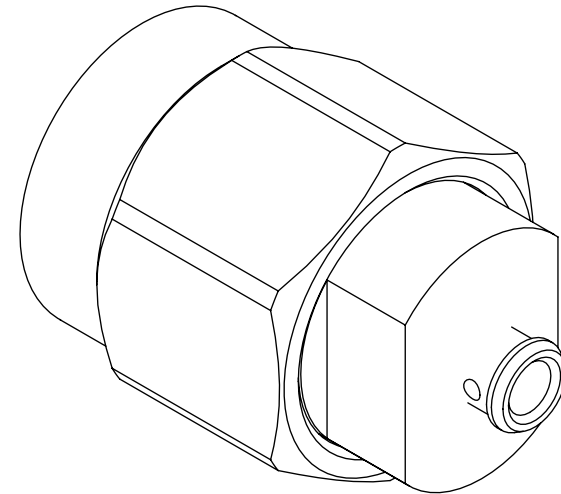

c:\enterprisevault\DWG\MISC\MKTG\PRF01-P-C-XX-047A-SD-MKT.SLDDRW

NOTES:

1. MATERIAL:
COUPLING NUT: 303 STAINLESS STEEL.
BODY: BRASS.
CONTACT & LOCK RING: BERYLLIUM COPPER.
GASKET: SILICONE RUBBER.
INSULATOR: TEFLON.

2. FINISH:
BODY: 10µ" MIN. GOLD OVER 50µ" MIN. NICKEL PLATE.
CONTACT: 50µ" MIN. GOLD OVER 50µ" MIN. NICKEL PLATE.

<p>PROPRIETARY NOTE</p> <p>THIS DOCUMENT CONTAINS CONFIDENTIAL AND PROPRIETARY INFORMATION AND ALL DESIGN, MANUFACTURING, REPRODUCTION, USE, PATENT RIGHTS AND SALES RIGHTS ARE EXPRESSLY RESERVED BY SAMTEC, INC. THIS DOCUMENT SHALL NOT BE DISCLOSED, IN WHOLE OR PART, TO ANY UNAUTHORIZED PERSON OR ENTITY NOR REPRODUCED, TRANSFERRED OR INCORPORATED IN ANY OTHER PROJECT IN ANY MANNER WITHOUT THE EXPRESS WRITTEN CONSENT OF SAMTEC, INC.</p>	 <p>520 PARK EAST BLVD., NEW ALBANY, IN 47150 PHONE: 812-944-6733 FAX: 812-948-5047 e-Mail info@SAMTEC.com code 55322</p>	
	<p>DO NOT SCALE DRAWING SHEET SCALE: 6:1</p>	<p>DESCRIPTION: SMA PLUG, DIRECT SOLDER FOR CCA-047-PFA CABLE</p>
	<p>DWG. NO. PRF01-P-C-XX-047A-SD</p> <p>BY: EVE L 11/02/2021 SHEET 1 OF 2</p>	

CABLE APPLICATION VIEWS

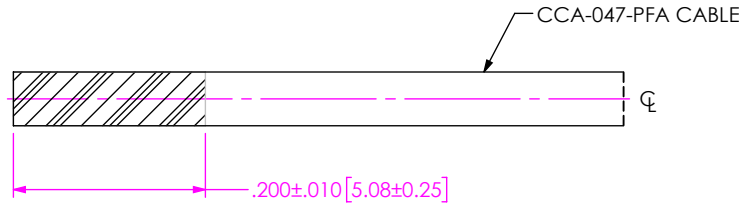

1. STRIP THEN PRE-TIN CABLE OVER LENGTH SHOWN.

IN-PROCESS VIEW 1

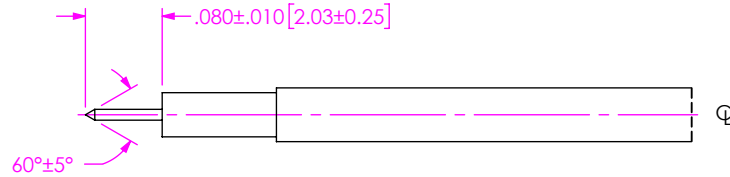

2. TRIM CABLE TO EXPOSE AND POINT CENTER CONDUCTOR AS SHOWN. (DO NOT SCORE CENTER CONDUCTOR)

IN-PROCESS VIEW 2

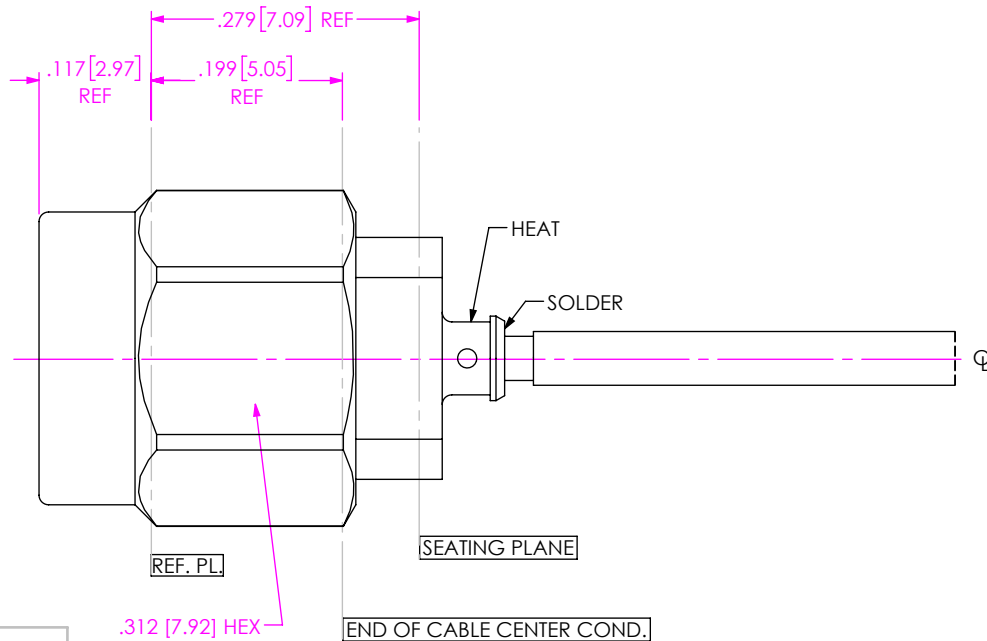

3. APPLY HEAT TO BODY TAIL WHERE SHOWN AND INSERT CABLE INTO CONNECTOR SUB-ASSEMBLY UNTIL FULLY SEATED. FLOW ADDITIONAL SOLDER WHERE SHOWN IF REQUIRED.

IN-PROCESS VIEW 3

PROPRIETARY NOTE
 THIS DOCUMENT CONTAINS CONFIDENTIAL AND PROPRIETARY INFORMATION AND ALL DESIGN, MANUFACTURING, REPRODUCTION, USE, PATENT RIGHTS AND SALES RIGHTS ARE EXPRESSLY RESERVED BY SAMTEC, INC. THIS DOCUMENT SHALL NOT BE DISCLOSED, IN WHOLE OR PART, TO ANY UNAUTHORIZED PERSON OR ENTITY NOR REPRODUCED, TRANSFERRED OR INCORPORATED IN ANY OTHER PROJECT IN ANY MANNER WITHOUT THE EXPRESS WRITTEN CONSENT OF SAMTEC, INC.



520 PARK EAST BLVD, NEW ALBANY, IN 47150
 PHONE: 812-944-6733 FAX: 812-948-5047
 e-Mail info@SAMTEC.com code 55322

DO NOT SCALE DRAWING

SHEET SCALE: 5:1

DESCRIPTION: SMA PLUG, DIRECT SOLDER FOR CCA-047-PFA CABLE

DWG. NO. PRF01-P-C-XX-047A-SD

BY: EVE L 11/02/2021 SHEET 2 OF 2