

DO NOT SCALE FROM THIS PRINT

DESIGNED & DIMENSIONED IN INCHES[MILLIMETERS]

PRF04-P-C-EP-200-SS

SERIES -04: TNCA
 GENDER -P: PLUG
 TYPE -C: CABLE
 FINISH -EP: 50µ" EXTRA HEAVY GOLD CENTER CONTACT, PASSIVATED OUTER CONTACT
 TERMINATION -S: SOLDER CLAMP
 ORIENTATION -S: STRAIGHT
 CABLE TYPE -200: CABLE (MAXGAIN 200)

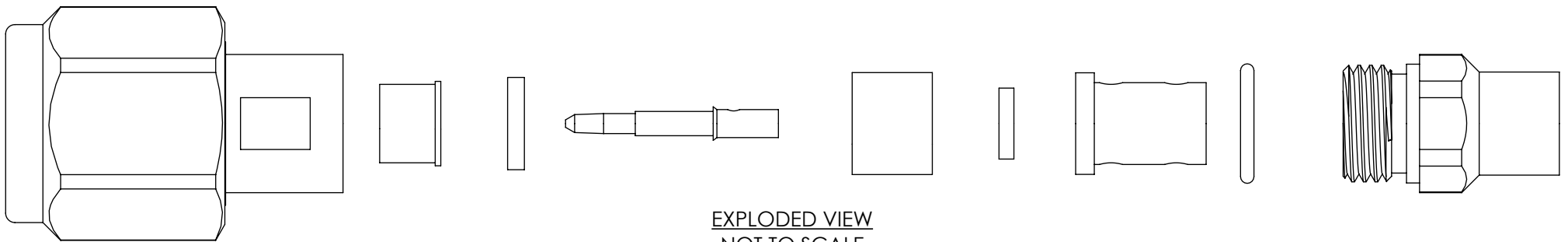
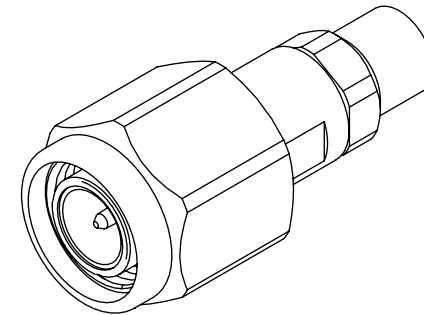
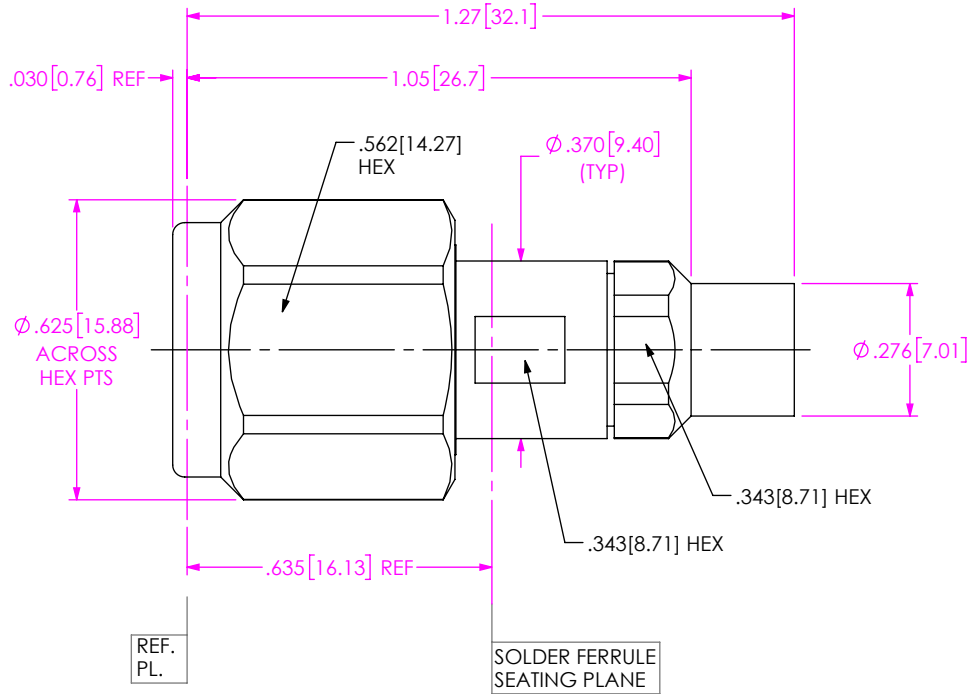

EXPLODED VIEW
 NOT TO SCALE
 (FOR CLARITY ONLY)

NOTES:

- MATERIAL:**
 BODY, BUSHING, CLAMP NUT, COUPLING NUT: STAINLESS STEEL
 CONTACT, LOCK RING: BERYLLIUM COPPER
 SOLDER FERRULE: BRASS ALLOY
 INSULATOR: PTFE
 BEADS: PEI
 O-RING, GASKET: SILICONE RUBBER
- FINISH:**
 BODY, BUSHING, CLAMP NUT, COUPLING NUT: PASSIVATED
 CONTACT, SOLDER FERRULE: 50µ" MIN. GOLD OVER 50µ" MIN. NICKEL PLATE
- PCI P/N: 3959

F:\DWG\MISC\MKTG\PRF04-P-C-EP-200-SS-MKT.SLDDRW

UNLESS OTHERWISE SPECIFIED, DIMENSIONS ARE IN INCHES. TOLERANCES ARE:
 DECIMALS .XX: ±.01 [0.3]
 .XXX: ±.005 [0.13]
 .XXXX: ±.0005 [0.013]

PROPRIETARY NOTE
 THIS DOCUMENT CONTAINS CONFIDENTIAL AND PROPRIETARY INFORMATION AND ALL DESIGN, MANUFACTURING, REPRODUCTION, USE, PATENT RIGHTS AND SALES RIGHTS ARE EXPRESSLY RESERVED BY SAMTEC, INC. THIS DOCUMENT SHALL NOT BE DISCLOSED, IN WHOLE OR PART, TO ANY UNAUTHORIZED PERSON OR ENTITY NOR REPRODUCED, TRANSFERRED OR INCORPORATED IN ANY OTHER PROJECT IN ANY MANNER WITHOUT THE EXPRESS WRITTEN CONSENT OF SAMTEC, INC.



520 PARK EAST BLVD, NEW ALBANY, IN 47150
 PHONE: 812-944-6733 FAX: 812-948-5047
 e-Mail info@SAMTEC.com code 55322

DO NOT SCALE DRAWING

SHEET SCALE: 2.5:1

DESCRIPTION: TNCA PLUG, SOLDER CLAMP FOR TIMES MAXGAIN 200 CABLE

DWG. NO. PRF04-P-C-EP-200-SS

BY: SHERRY W 8/5/2020 SHEET 1 OF 3

CABLE APPLICATION VIEWS

1A. TRIM CABLE AS SHOWN.

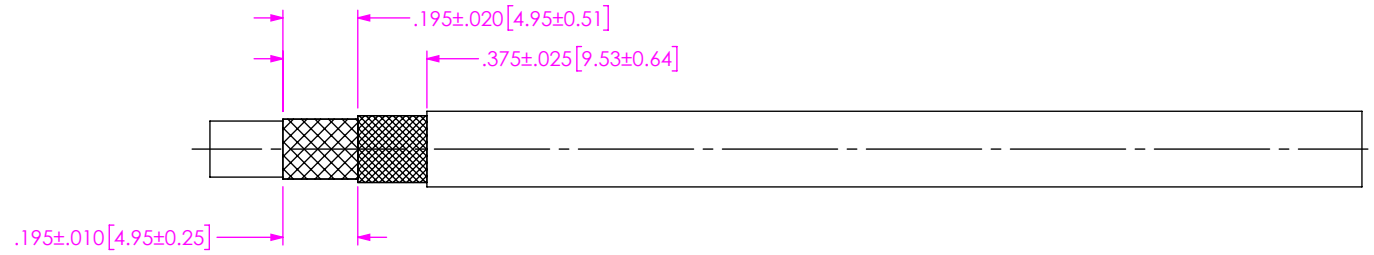

IN-PROCESS VIEW 1

2A. SLIDE CLAMP NUT OVER CABLE AS SHOWN.

2B. INSERT CABLE INTO SOLDER FERRULE UNTIL INNER SHIELD SEATS AND SOLDER TO BRAIDS WHERE SHOWN.

2C. TRIM CABLE DIELECTRIC FLUSH TO SOLDER FERRULE.

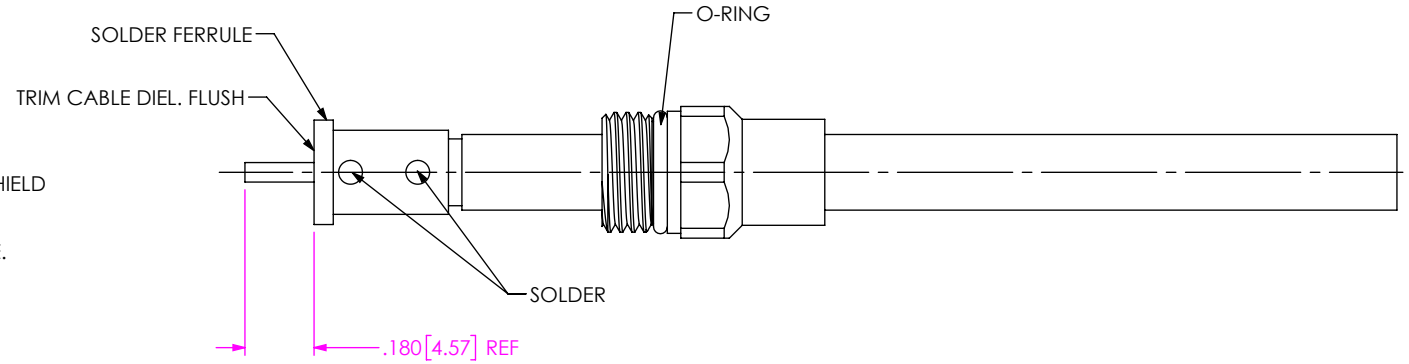

IN-PROCESS VIEW 2

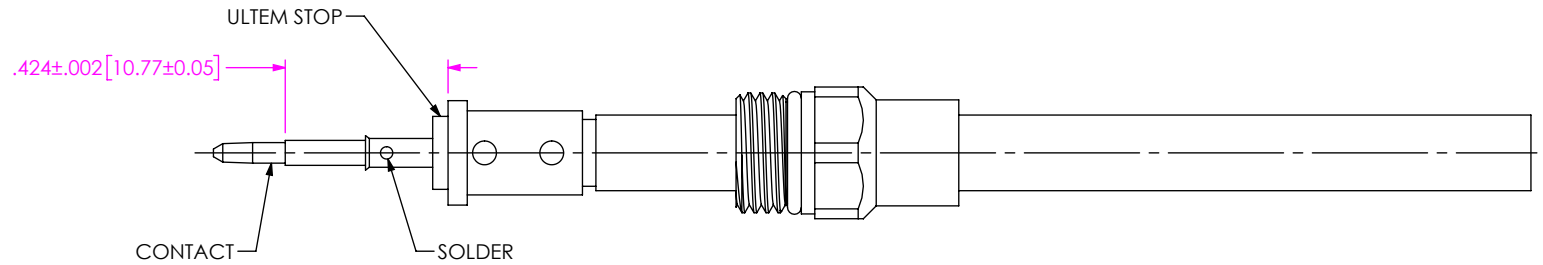

3A. SLIDE ULTEM DIELECTRIC STOP OVER CABLE CENTER CONTACT AGAINST SOLDER FERRULE AS SHOWN.

3B. SOLDER CONTACT FLUSH AGAINST STOP TO DIMENSION SHOWN.

IN-PROCESS VIEW 3

PROPRIETARY NOTE
 THIS DOCUMENT CONTAINS CONFIDENTIAL AND PROPRIETARY INFORMATION AND ALL DESIGN, MANUFACTURING, REPRODUCTION, USE, PATENT RIGHTS AND SALES RIGHTS ARE EXPRESSLY RESERVED BY SAMTEC, INC. THIS DOCUMENT SHALL NOT BE DISCLOSED, IN WHOLE OR PART, TO ANY UNAUTHORIZED PERSON OR ENTITY NOR REPRODUCED, TRANSFERRED OR INCORPORATED IN ANY OTHER PROJECT IN ANY MANNER WITHOUT THE EXPRESS WRITTEN CONSENT OF SAMTEC, INC.



520 PARK EAST BLVD, NEW ALBANY, IN 47150
 PHONE: 812-944-6733 FAX: 812-948-5047
 e-Mail info@SAMTEC.com code 55322

DO NOT SCALE DRAWING
 SHEET SCALE: 2:1

DESCRIPTION: TNCA PLUG, SOLDER CLAMP FOR TIMES MAXGAIN 200 CABLE

DWG. NO. PRF04-P-C-EP-200-SS

BY: SHERRY W 8/5/2020 SHEET 2 OF 3

CABLE APPLICATION VIEWS

***** NOTE *****
 BUSHING WILL NOT SEAT AGAINST SOLDER FERRULE IF ORIENTATION IS REVERSED.

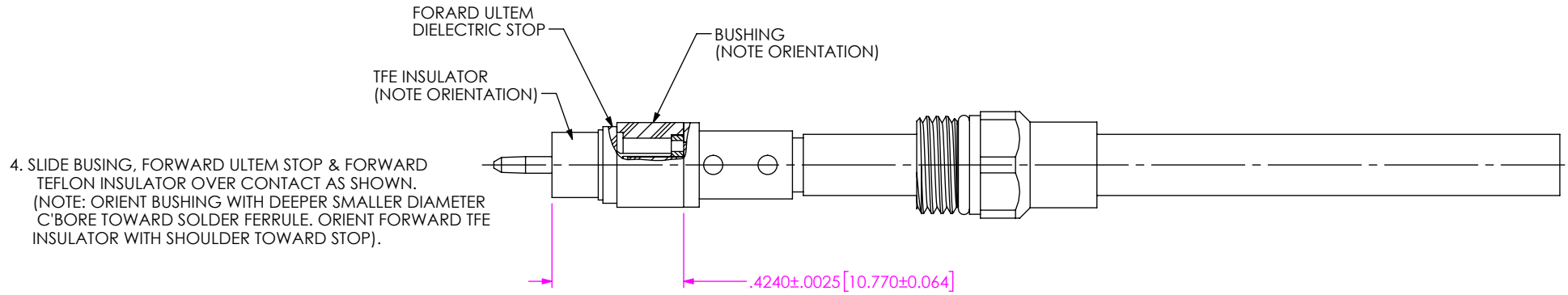

IN-PROCESS VIEW 4

5A. INSERT CABLE/CONTACT SUB-ASSEMBLY INTO CONNECTOR UNTIL SEATED AND TIGHTEN CLAMP NUT TO 35-45 IN-LBS.

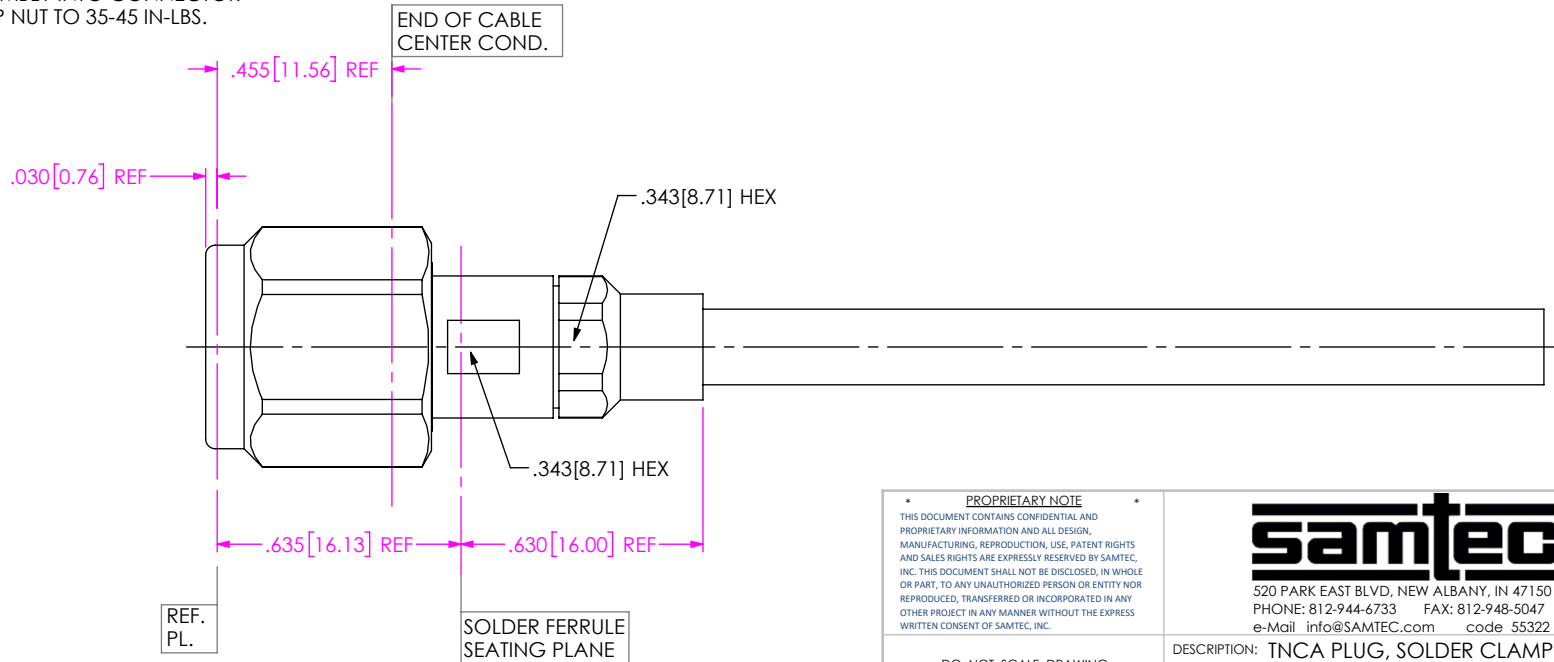

IN-PROCESS VIEW 5

• PROPRIETARY NOTE •
 THIS DOCUMENT CONTAINS CONFIDENTIAL AND PROPRIETARY INFORMATION AND ALL DESIGN, MANUFACTURING, REPRODUCTION, USE, PATENT RIGHTS AND SALES RIGHTS ARE EXPRESSLY RESERVED BY SAMTEC, INC. THIS DOCUMENT SHALL NOT BE DISCLOSED, IN WHOLE OR PART, TO ANY UNAUTHORIZED PERSON OR ENTITY NOR REPRODUCED, TRANSFERRED OR INCORPORATED IN ANY OTHER PROJECT IN ANY MANNER WITHOUT THE EXPRESS WRITTEN CONSENT OF SAMTEC, INC.



520 PARK EAST BLVD, NEW ALBANY, IN 47150
 PHONE: 812-944-6733 FAX: 812-948-5047
 e-Mail info@SAMTEC.com code 55322

DO NOT SCALE DRAWING

SHEET SCALE: 2:1

DESCRIPTION: TNCA PLUG, SOLDER CLAMP FOR TIMES MAXGAIN 200 CABLE

DWG. NO. PRF04-P-C-EP-200-SS

BY: SHERRY W 8/5/2020 SHEET 3 OF 3