

DESIGNED & DIMENSIONED
IN INCHES[MILLIMETERS]

PRF04-P-C-EP-300A-SS

DO NOT
SCALE FROM
THIS PRINT

SERIES
-04: TNCA

GENDER
-P: PLUG

TYPE
-C: CABLE

TERMINATION
S: SOLDER CLAMP

ORIENTATION
-S: STRAIGHT

CABLE TYPE
-300A: CABLE (MAXGAIN 300)

FINISH
-EP: 50µ" EXTRA HEAVY GOLD
CENTER CONTACT, PASSIVATED
OUTER CONTACT

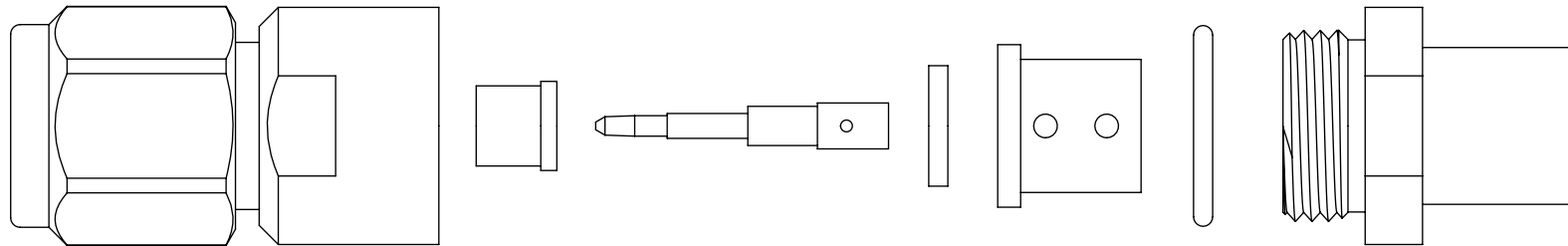
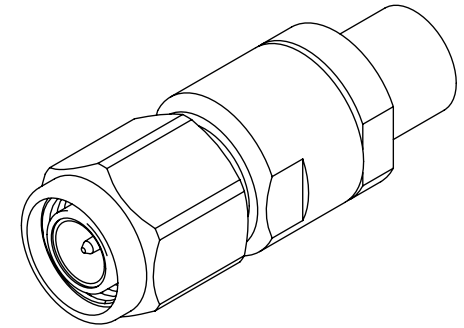
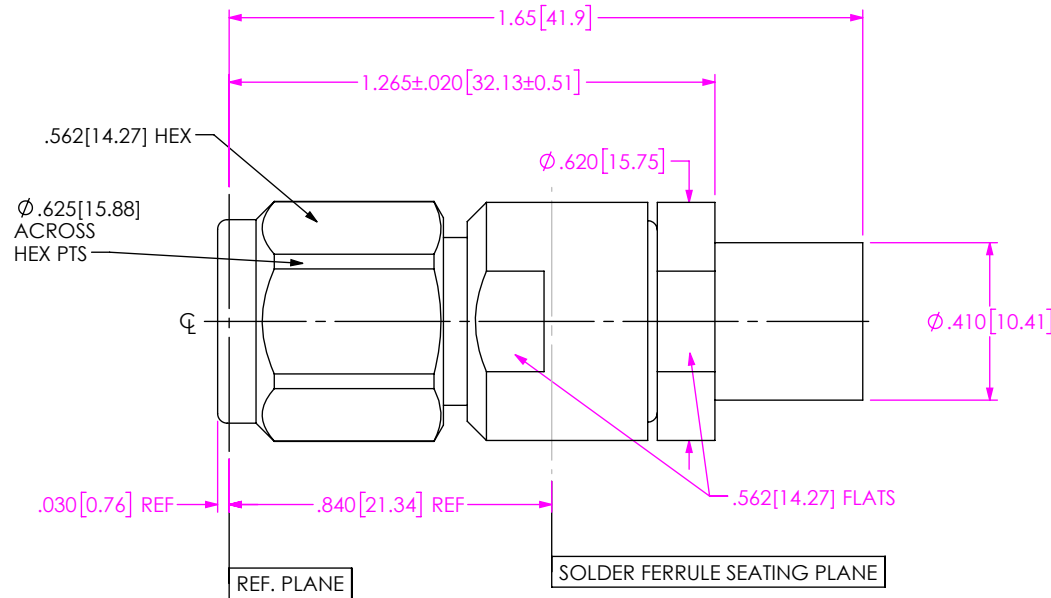

EXPLODED VIEW
NOT TO SCALE
(FOR CLARITY ONLY)

NOTES:

- MATERIAL:
BODY, COUPLING NUT & CLAMP NUT: STAINLESS STEEL.
PIN & LOCK RING: BERYLLIUM COPPER.
SOLDER FERRULE: BRASS.
GASKET & O-RING: SILICONE RUBBER.
INSULATOR: TEFLON.
BEAD: ULTEM 1000.
- FINISH:
BODY, COUPLING NUT & CLAMP NUT: PASSIVATED.
PIN & SOLDER FERRULE: GOLD OVER NICKEL PLATE,
50 µ" MIN GOLD OVER 50 µ" MIN NICKEL.
- PCI P/N: 3952.

UNLESS OTHERWISE SPECIFIED,
DIMENSIONS ARE IN INCHES.
TOLERANCES ARE:
DECIMALS ANGLES
.XX: ± .02[0.5]
.XXX: ± .005[0.13]
.XXXX: ± .0005[0.013]

PROPRIETARY NOTE
THIS DOCUMENT CONTAINS CONFIDENTIAL AND
PROPRIETARY INFORMATION AND ALL DESIGN,
MANUFACTURING, REPRODUCTION, USE, PATENT RIGHTS
AND SALES RIGHTS ARE EXPRESSLY RESERVED BY SAMTEC,
INC. THIS DOCUMENT SHALL NOT BE DISCLOSED, IN WHOLE
OR PART, TO ANY UNAUTHORIZED PERSON OR ENTITY NOR
REPRODUCED, TRANSFERRED OR INCORPORATED IN ANY
OTHER PROJECT IN ANY MANNER WITHOUT THE EXPRESS
WRITTEN CONSENT OF SAMTEC, INC.



520 PARK EAST BLVD, NEW ALBANY, IN 47150
PHONE: 812-944-6733 FAX: 812-948-5047
e-Mail info@SAMTEC.com code 55322

DO NOT SCALE DRAWING

SHEET SCALE: 2:1

DESCRIPTION: TNCA PLUG, SOLDER CLAMP FOR
TIMES MAXGAIN 300 CABLE

DWG. NO. PRF04-P-C-EP-300A-SS

BY: SHERRY W 7/23/2020 SHEET 1 OF 2

CABLE APPLICATION VIEWS

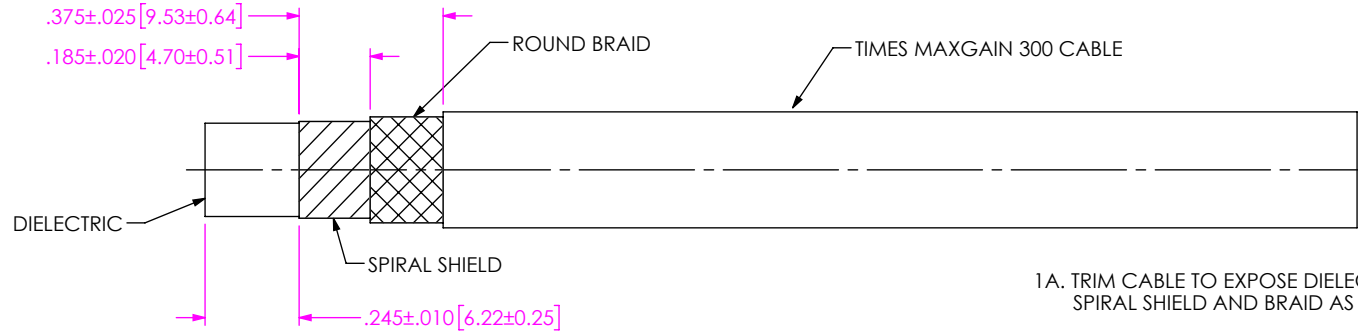

IN-PROCESS VIEW 1

1A. TRIM CABLE TO EXPOSE DIELECTRIC CORE SPIRAL SHIELD AND BRAID AS SHOWN.

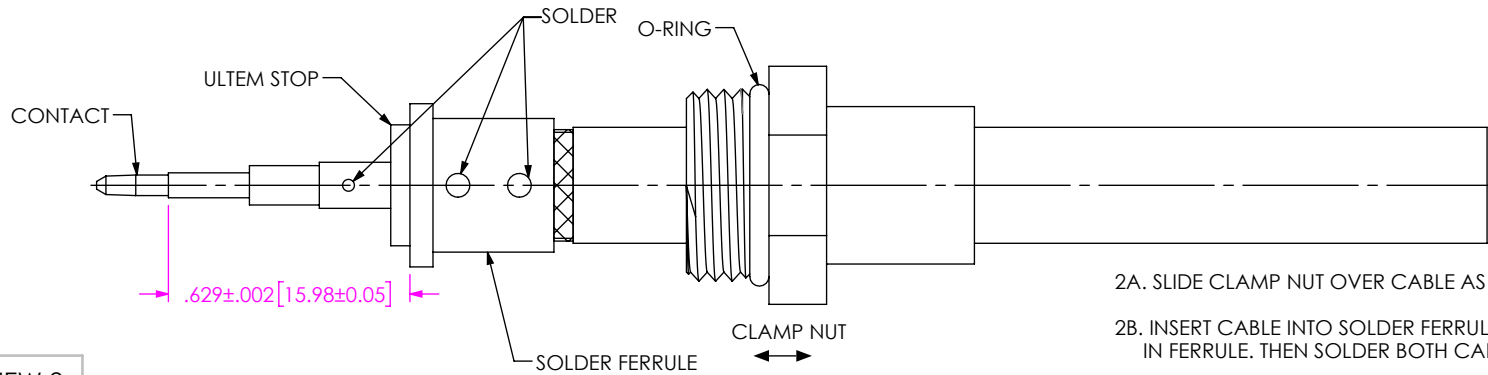

IN-PROCESS VIEW 2

2A. SLIDE CLAMP NUT OVER CABLE AS SHOWN.
 2B. INSERT CABLE INTO SOLDER FERRULE UNTIL INNER SHIELD SEATS IN FERRULE. THEN SOLDER BOTH CABLE BRAIDS WHERE SHOWN.
 2C. TRIM CABLE DIELECTRIC FLUSH WITH FACE OF FERRULE.
 2D. SLIDE DIELECTRIC STOP OVER CABLE CENTER CONDUCTOR AND SOLDER CONTACT FLUSH AGAINST STOP TO DIMENSION SHOWN.

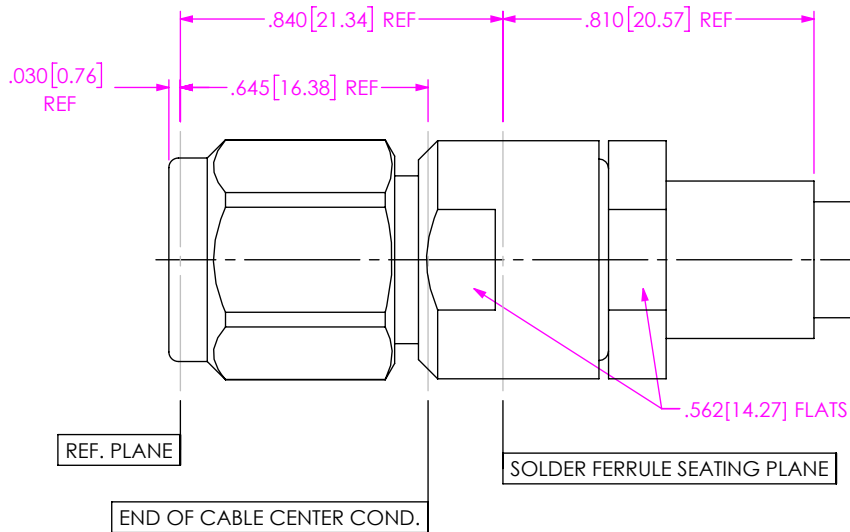

IN-PROCESS VIEW 3

3A. INSERT FORWARD INSULATOR INTO CONNECTOR IN ORIENTATION SHOWN.
 3B. INSERT CABLE/CONTACT SUB-ASSEMBLY INTO CONNECTOR UNTIL SEATED AND TIGHTEN CLAMP NUT TO 35-45 IN-LBS.

PROPRIETARY NOTE
 THIS DOCUMENT CONTAINS CONFIDENTIAL AND PROPRIETARY INFORMATION AND ALL DESIGN, MANUFACTURING, REPRODUCTION, USE, PATENT RIGHTS AND SALES RIGHTS ARE EXPRESSLY RESERVED BY SAMTEC, INC. THIS DOCUMENT SHALL NOT BE DISCLOSED, IN WHOLE OR PART, TO ANY UNAUTHORIZED PERSON OR ENTITY NOR REPRODUCED, TRANSFERRED OR INCORPORATED IN ANY OTHER PROJECT IN ANY MANNER WITHOUT THE EXPRESS WRITTEN CONSENT OF SAMTEC, INC.



DO NOT SCALE DRAWING
 SHEET SCALE: 2:1

DESCRIPTION: TNCA PLUG, SOLDER CLAMP FOR TIMES MAXGAIN 300 CABLE

DWG. NO. PRF04-P-C-EP-300A-SS

BY: SHERRY W 7/23/2020 SHEET 2 OF 2