

DO NOT  
SCALE FROM  
THIS PRINT

DESIGNED & DIMENSIONED  
IN INCHES[MILLIMETERS]

PRF06-P-C-EP-305-SS

SERIES  
-06: NTPPE

GENDER  
-P: PLUG

TYPE  
-C: CABLE

FINISH  
-EP: 50µ" EXTRA HEAVY GOLD  
CENTER CONTACT, PASSIVATED  
OUTER CONTACT

TERMINATION  
-S: SOLDER CLAMP

ORIENTATION  
-S: STRAIGHT

CABLE TYPE  
-305: SEMFLEX HP305

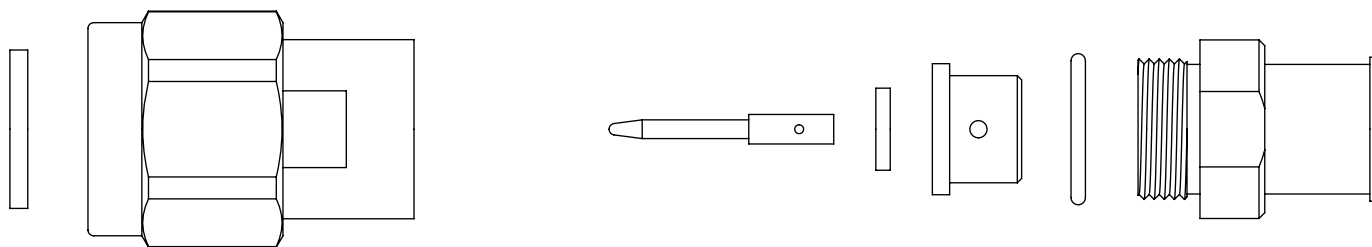
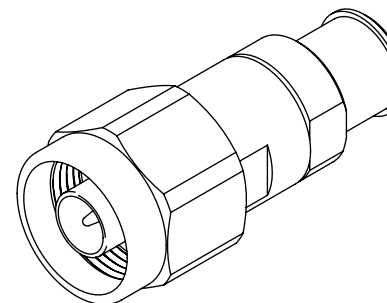
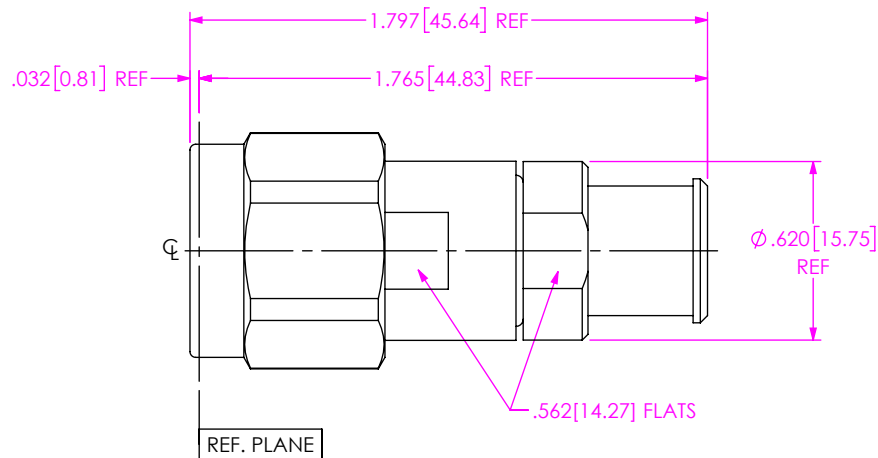

EXPLODED VIEW  
NOT TO SCALE  
(FOR CLARITY ONLY)

NOTES:

- MATERIAL:  
BODY, COUPLING NUT & CLAMP NUT: STAINLESS STEEL.  
PIN & LOCK RING: BERYLLIUM COPPER.  
SOLDER FERRULE: BRASS.  
GASKET & O-RING: SILICONE RUBBER.  
INSULATOR: PTFE.  
BEADS: ULTEM 1000.
- FINISH:  
BODY, COUPLING NUT & CLAMP NUT: PASSIVATED.  
PIN & SOLDER FERRULE: GOLD OVER NICKEL PLATE,  
50 µIN MIN GOLD OVER 50 µIN MIN NICKEL.
- PCI P/N: 3260.

UNLESS OTHERWISE SPECIFIED,  
DIMENSIONS ARE IN INCHES.

TOLERANCES ARE:

DECIMALS      ANGLES  
.XX: ±.01 [0.3]      1°  
.XXX: ±.005 [0.13]  
.XXXX: ±.0005 [0.013]

PROPRIETARY NOTE

THIS DOCUMENT CONTAINS CONFIDENTIAL AND PROPRIETARY INFORMATION AND ALL DESIGN, MANUFACTURING, REPRODUCTION, USE, PATENT RIGHTS AND SALES RIGHTS ARE EXPRESSLY RESERVED BY SAMTEC, INC. THIS DOCUMENT SHALL NOT BE DISCLOSED, IN WHOLE OR PART, TO ANY UNAUTHORIZED PERSON OR ENTITY NOR REPRODUCED, TRANSFERRED OR INCORPORATED IN ANY OTHER PROJECT IN ANY MANNER WITHOUT THE EXPRESS WRITTEN CONSENT OF SAMTEC, INC.



520 PARK EAST BLVD., NEW ALBANY, IN 47150  
PHONE: 812-944-6733    FAX: 812-948-5047  
e-Mail: info@SAMTEC.com    code 55322

DO NOT SCALE DRAWING

SHEET SCALE: 3:2

DESCRIPTION: NTPPE PLUG (18 GHZ), SOLDER CLAMP FOR SEMFLEX HP305 CABLE

DWG. NO. PRF06-P-C-EP-305-SS

BY: CHRISTIAN S. 05/06/2019 SHEET 1 OF 2

1. TRIM CABLE AS SHOWN.

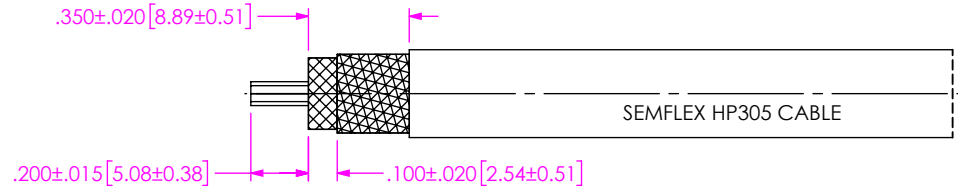

IN-PROCESS 1

2A. SLIDE CLAMP NUT OVER CABLE AS SHOWN.

2B. INSERT CABLE INTO SOLDER FERRULE UNTIL CABLE DIELECTRIC AND BRAID ARE FLUSH WITH FACE OF FERRULE. THEN SOLDER CABLE BRAIDS WHERE SHOWN.

2C. SLIDE DIELECTRIC STOP OVER CABLE CENTER CONDUCTOR AND SOLDER CONTACT FLUSH AGAINST STOP TO DIMENSION SHOWN.

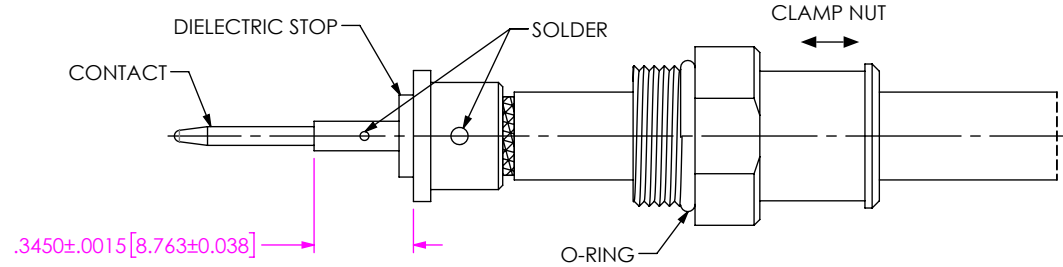

IN-PROCESS 2

3. INSERT CABLE/CONTACT SUB-ASSEMBLY INTO CONNECTOR UNTIL SEATED AND TIGHTEN CLAMP NUT TO 35-45 IN-LBS.

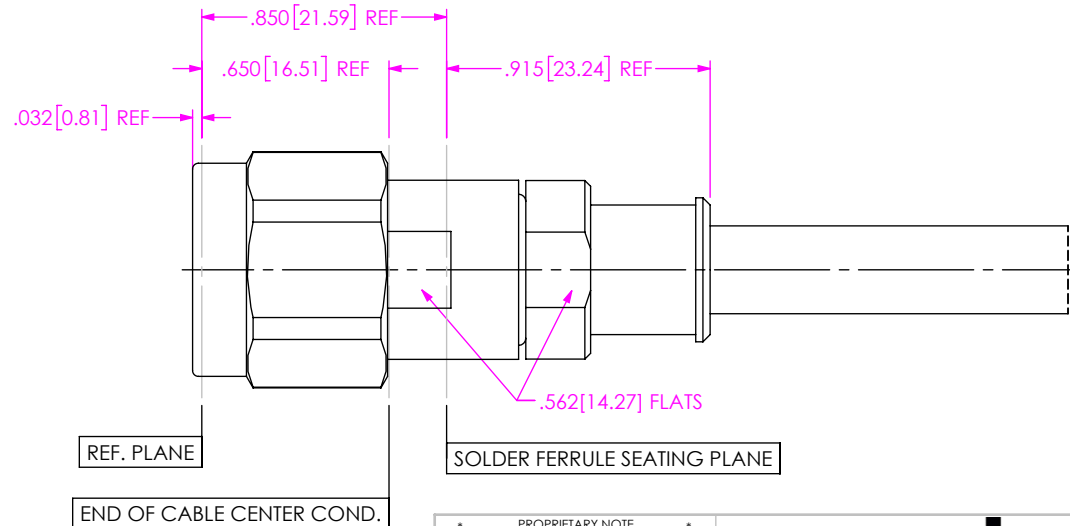

IN-PROCESS 3

**PROPRIETARY NOTE**  
 THIS DOCUMENT CONTAINS CONFIDENTIAL AND PROPRIETARY INFORMATION AND ALL DESIGN, MANUFACTURING, REPRODUCTION, USE, PATENT RIGHTS AND SALES RIGHTS ARE EXPRESSLY RESERVED BY SAMTEC, INC. THIS DOCUMENT SHALL NOT BE DISCLOSED, IN WHOLE OR PART, TO ANY UNAUTHORIZED PERSON OR ENTITY NOR REPRODUCED, TRANSFERRED OR INCORPORATED IN ANY OTHER PROJECT IN ANY MANNER WITHOUT THE EXPRESS WRITTEN CONSENT OF SAMTEC, INC.



520 PARK EAST BLVD, NEW ALBANY, IN 47150  
 PHONE: 812-944-6733 FAX: 812-948-5047  
 e-Mail info@SAMTEC.com code 55322

DO NOT SCALE DRAWING

SHEET SCALE: 3:2

DESCRIPTION: NTPE PLUG (18 GHZ), SOLDER CLAMP FOR SEMIFLEX HP305 CABLE

DWG. NO. PRF06-P-C-EP-305-SS

BY: CHRISTIAN S. 05/06/2019 SHEET 2 OF 2