

DO NOT SCALE FROM THIS PRINT

PRF10-J-C-VP-047D-SS-X

**SERIES**  
-10: 1.0 MM

**GENDER**  
-J: JACK

**TYPE**  
-C: CABLE

**PACKAGING**  
-B: BULK (IN INCREMENTS OF 50)  
(BLANK): STANDARD PACKAGING

**TERMINATION**  
-S: SOLDER CLAMP

**ORIENTATION**  
-S: STRAIGHT

**CABLE TYPE**  
-047D: .047" SEMI-RIGID CABLE

**PLATING**  
-VP: 50µ"-75µ" PRECISION GOLD CENTER CONTACT, PASSIVATED OUTER CONTACT

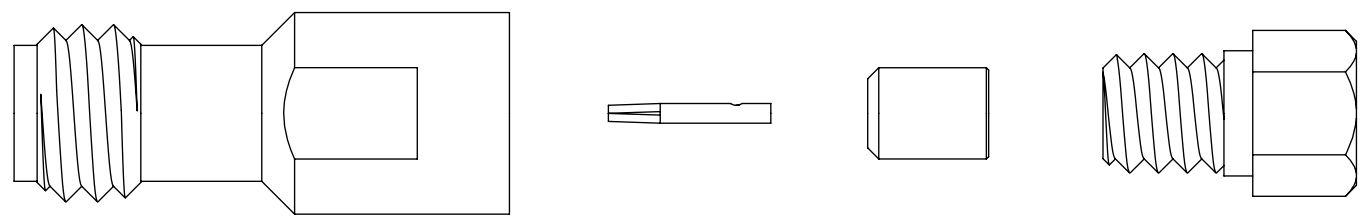
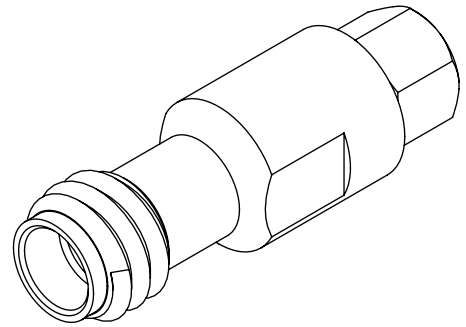
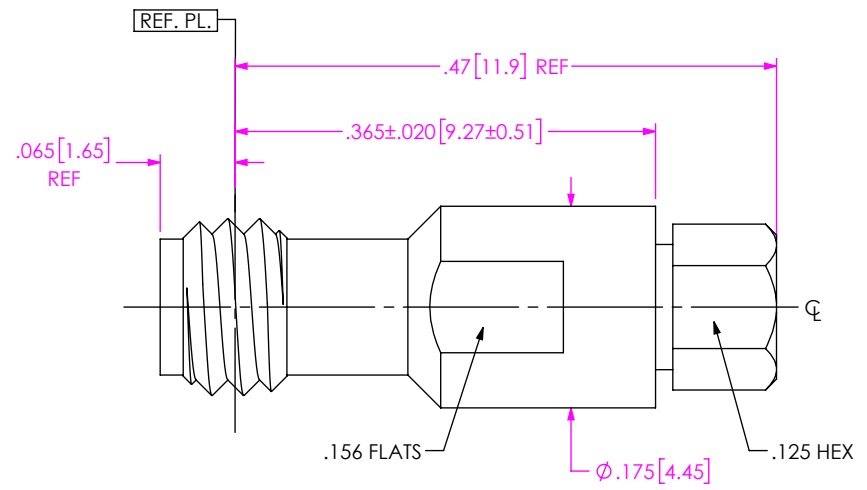

**EXPLODED VIEW**  
**NOT TO SCALE**  
(FOR CLARITY ONLY)

- NOTES:**
- MATERIALS:**  
BODY, CLAMP NUT: STAINLESS STEEL  
CONTACT: BERYLLIUM COPPER  
SOLDER FERRULE: BRASS ALLOY
  - FINISH:**  
BODY, CLAMP NUT: PASSIVATED  
CONTACT: 50µ"-75µ" GOLD OVER 50µ"-75µ" NICKEL PLATE  
SOLDER FERRULE: 50µ" GOLD OVER 50µ" NICKEL PLATE
  - PERFORMANCE:**  
IMPEDANCE: 50 Ω  
FREQUENCY: DC TO 110 GHz  
VSWR: 1.16:1 MAXIMUM  
INSERTION LOSS: 0.03 x √f(GHz)  
DWV: 600 Vrms
  - PCI P/N: 3633.
  - BULK PACKAGING OPTION (-B) FOR ORDERS IN INCREMENTS OF 50 PCS.

F:\DWG\MISC\MKTG\PRF10-J-C-VP-047D-SS-X-MKT.SLDDRW

UNLESS OTHERWISE SPECIFIED, DIMENSIONS ARE IN INCHES. TOLERANCES ARE: DECIMALS                      ANGLES .XX: ±.01 [0.3]                      1° .XXX: ±.005 [0.13] .XXXX: ±.0005 [0.013]	* <b>PROPRIETARY NOTE</b> * THIS DOCUMENT CONTAINS CONFIDENTIAL AND PROPRIETARY INFORMATION AND ALL DESIGN, MANUFACTURING, REPRODUCTION, USE, PATENT RIGHTS AND SALES RIGHTS ARE EXPRESSLY RESERVED BY SAMTEC, INC. THIS DOCUMENT SHALL NOT BE DISCLOSED, IN WHOLE OR PART, TO ANY UNAUTHORIZED PERSON OR ENTITY NOR REPRODUCED, TRANSFERRED OR INCORPORATED IN ANY OTHER PROJECT IN ANY MANNER WITHOUT THE EXPRESS WRITTEN CONSENT OF SAMTEC, INC.	 520 PARK EAST BLVD, NEW ALBANY, IN 47150 PHONE: 812-944-6733    FAX: 812-948-5047 e-Mail info@SAMTEC.com    code 55322

# CABLE APPLICATION VIEWS

1. TRIM CABLE TO EXPOSE CENTER DIELECTRIC AS SHOWN.
2. PRE-TIN CABLE OUTER JACKET OVER APPROX. LENGTH SHOWN

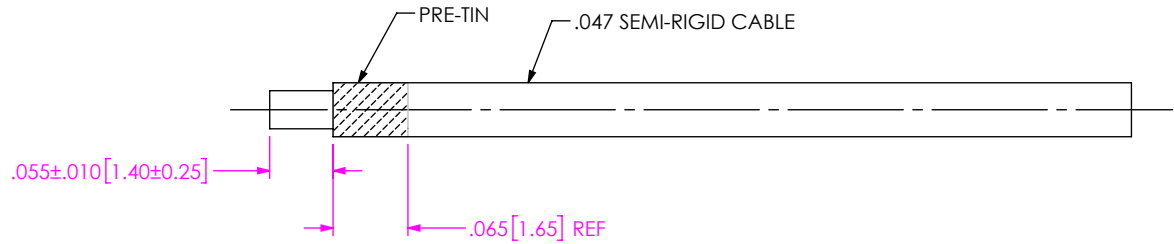

IN-PROCESS VIEW 1

- 2A: SLIDE CLAMP NUT ONTO CABLE AS SHOWN.
- 2B: INSTALL CABLE INTO SOLDER FERRULE UNTIL CABLE IS FULLY SEATED. THEN SOLDER CABLE TO FERRULE WHERE SHOWN
- 2C: TRIM DIELECTRIC CORE FLUSH TO SOLDER FERRULE TO EXPOSE CONDUCTOR (NOTE: DO NOT SCORE CENTER COND.)
- 2D: SOLDER CONTACT WITH GAP SHOWN USING SHIM.

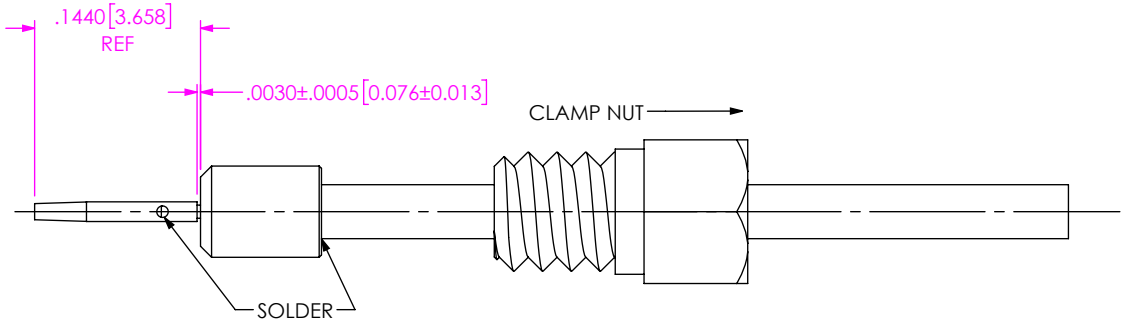

SLIGHT PRESS FIT BETWEEN CABLE DIELECTRIC AND SOLDER FERRULE.

IN-PROCESS VIEW 2

INTERFACE SUPPORT TOOL 450250

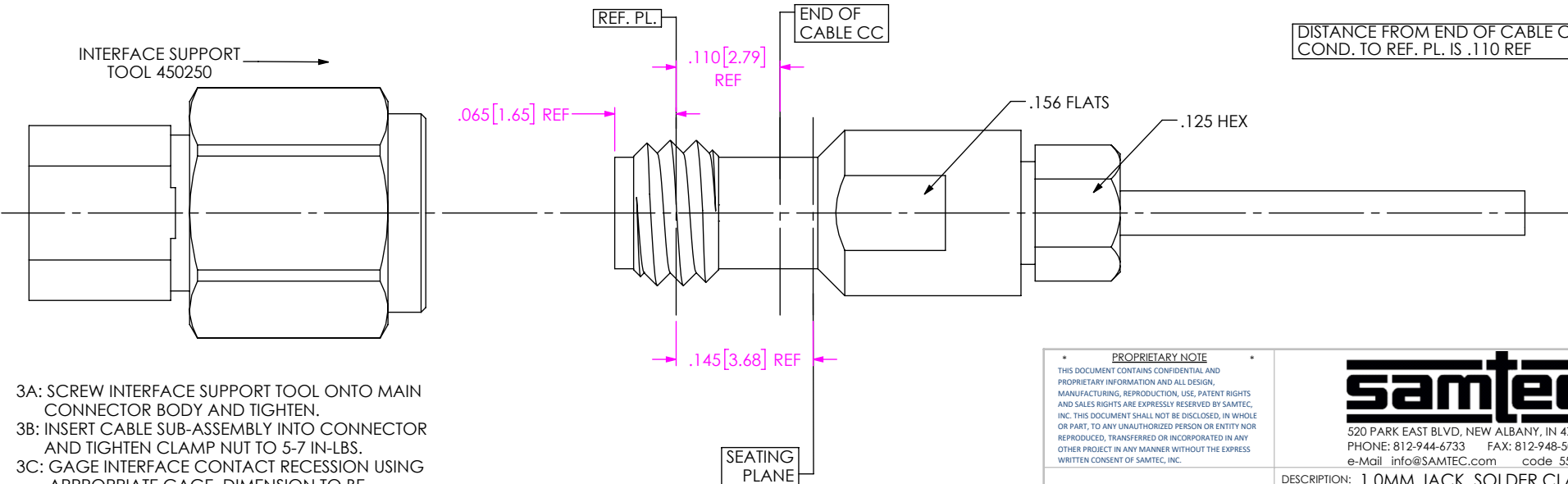

- 3A: SCREW INTERFACE SUPPORT TOOL ONTO MAIN CONNECTOR BODY AND TIGHTEN.
- 3B: INSERT CABLE SUB-ASSEMBLY INTO CONNECTOR AND TIGHTEN CLAMP NUT TO 5-7 IN-LBS.
- 3C: GAGE INTERFACE CONTACT RECESSION USING APPROPRIATE GAGE. DIMENSION TO BE .000/.003 SUB-FLUSH

IN-PROCESS VIEW 3

**PROPRIETARY NOTE**  
 THIS DOCUMENT CONTAINS CONFIDENTIAL AND PROPRIETARY INFORMATION AND ALL DESIGN, MANUFACTURING, REPRODUCTION, USE, PATENT RIGHTS AND SALES RIGHTS ARE EXPRESSLY RESERVED BY SAMTEC, INC. THIS DOCUMENT SHALL NOT BE DISCLOSED, IN WHOLE OR PART, TO ANY UNAUTHORIZED PERSON OR ENTITY NOR REPRODUCED, TRANSFERRED OR INCORPORATED IN ANY OTHER PROJECT IN ANY MANNER WITHOUT THE EXPRESS WRITTEN CONSENT OF SAMTEC, INC.



520 PARK EAST BLVD, NEW ALBANY, IN 47150  
 PHONE: 812-944-6733 FAX: 812-948-5047  
 e-Mail: info@SAMTEC.com code 55322

DO NOT SCALE DRAWING

SHEET SCALE: 6:1

DESCRIPTION: 1.0MM JACK, SOLDER CLAMP FOR .047" SEMI-RIGID CABLE

DWG. NO. PRF10-J-C-VP-047D-SS-X

BY: HENSON T 04/06/2019 SHEET 2 OF 2