

DO NOT SCALE FROM THIS PRINT

DESIGNED & DIMENSIONED IN INCHES[MILLIMETERS]

PRF92-J-C-EP-160-SS

SERIES
-92: 2.92 mm

GENDER
-J: JACK

TYPE
-C: CABLE

FINISH
-EP: 50µ" EXTRA HEAVY GOLD CENTER CONTACT, PASSIVATED OUTER CONTACT

TERMINATION
-S: SOLDER CLAMP

ORIENTATION
-S: STRAIGHT

CABLE TYPE
-160: SEMFLEX HP160

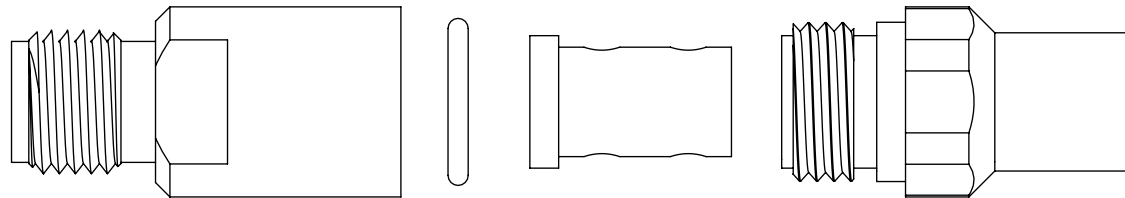
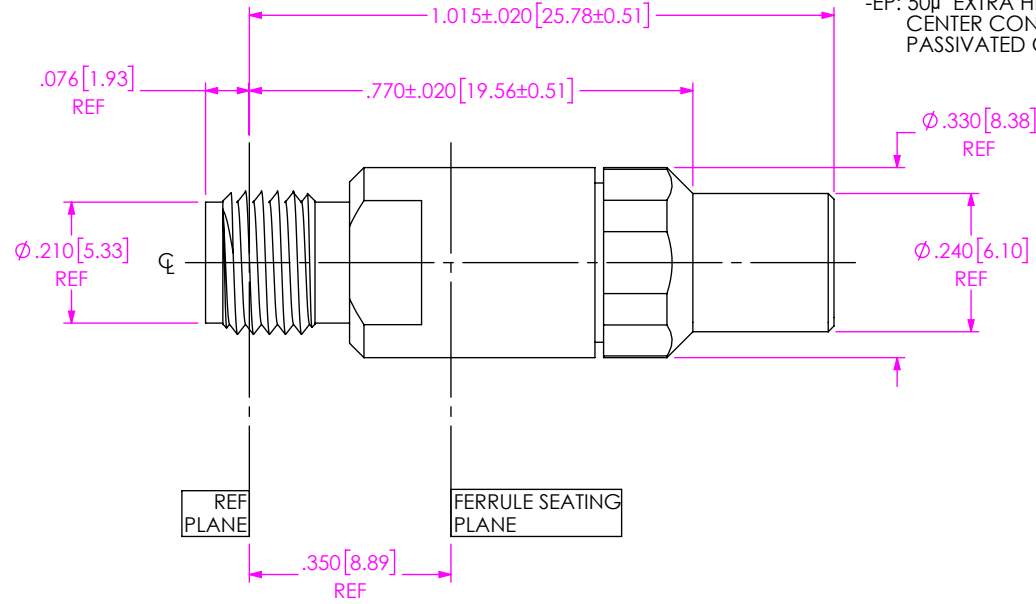

EXPLODED VIEW
NOT TO SCALE
(FOR CLARITY ONLY)

NOTES:

- MATERIAL:
BODY, CLAMP NUT: STAINLESS STEEL.
O-RING: SILICONE RUBBER.
BEAD: PEI.
SOLDER FERRULE: BRASS ALLOY
CONTACT: BERYLLIUM COPPER.
- FINISH:
BODY, BUSHING, CLAMP NUT: PASSIVATED.
CONTACT, SOLDER FERRULE: GOLD OVER NICKEL PLATE,
50 µIN MIN GOLD OVER 50 µIN MIN NICKEL.
- PCI P/N: 3312.

UNLESS OTHERWISE SPECIFIED, DIMENSIONS ARE IN INCHES. TOLERANCES ARE: DECIMALS .XX: ± .01 .XXX: ± .005 .XXXX: ± .0005 ANGLES 1°	* PROPRIETARY NOTE * THIS DOCUMENT CONTAINS CONFIDENTIAL AND PROPRIETARY INFORMATION AND ALL DESIGN, MANUFACTURING, REPRODUCTION, USE, PATENT RIGHTS AND SALES RIGHTS ARE EXPRESSLY RESERVED BY SAMTEC, INC. THIS DOCUMENT SHALL NOT BE DISCLOSED, IN WHOLE OR PART, TO ANY UNAUTHORIZED PERSON OR ENTITY NOR REPRODUCED, TRANSFERRED OR INCORPORATED IN ANY OTHER PROJECT IN ANY MANNER WITHOUT THE EXPRESS WRITTEN CONSENT OF SAMTEC, INC.	 520 PARK EAST BLVD., NEW ALBANY, IN 47150 PHONE: 812-944-6733 FAX: 812-948-5047 e-Mail info@SAMTEC.com code 55322
		DESCRIPTION: 2.92MM JACK, SOLDER CLAMP FOR SEMFLEX HP160 DWG. NO. PRF92-J-C-EP-160-SS BY: SAMUEL C 05/06/2019 SHEET 1 OF 3

CABLE APPLICATION VIEWS

1A. TRIM CABLE AS SHOWN.

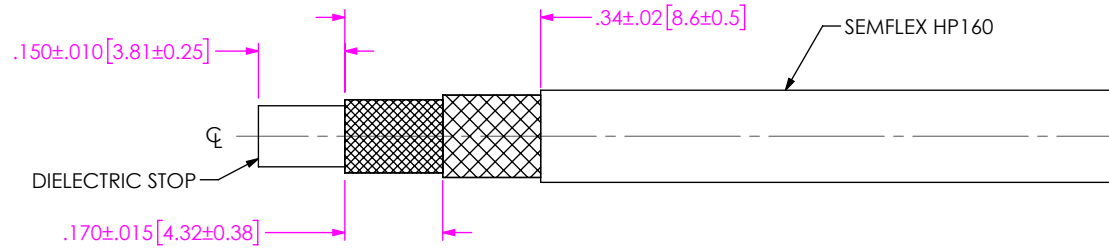

IN-PROCESS VIEW 1

2A. INSTALL O-RING ONTO CLAMP NUT WHERE SHOWN AND SLIDE CLAMP NUT OVER CABLE AS SHOWN.
 2B. INSERT CABLE INTO SOLDER FERRULE UNTIL SEATED AND SOLDER TO CABLE BRAIDS AS SHOWN.

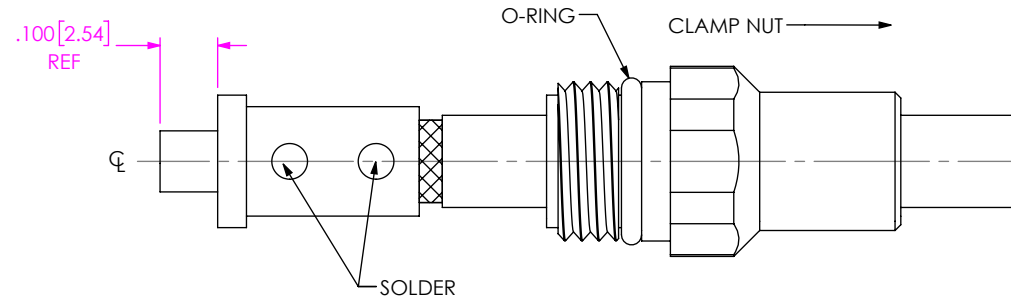

IN-PROCESS VIEW 2

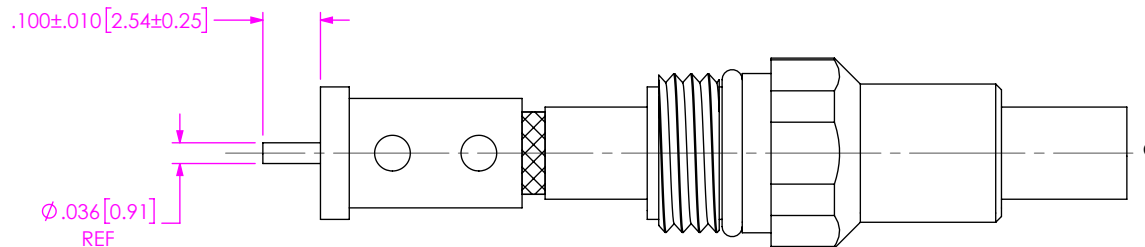

3A. TRIM DIELECTRIC FLUSH WITH SEATING SURFACE OF SOLDER FERRULE.
 3B. VERIFY CENTER CONDUCTOR DIM. SHOWN FROM FERRULE SEATING SURFACE.

IN-PROCESS VIEW 3

PROPRIETARY NOTE
 THIS DOCUMENT CONTAINS CONFIDENTIAL AND PROPRIETARY INFORMATION AND ALL DESIGN, MANUFACTURING, REPRODUCTION, USE, PATENT RIGHTS AND SALES RIGHTS ARE EXPRESSLY RESERVED BY SAMTEC, INC. THIS DOCUMENT SHALL NOT BE DISCLOSED, IN WHOLE OR PART, TO ANY UNAUTHORIZED PERSON OR ENTITY NOR REPRODUCED, TRANSFERRED OR INCORPORATED IN ANY OTHER PROJECT IN ANY MANNER WITHOUT THE EXPRESS WRITTEN CONSENT OF SAMTEC, INC.

DO NOT SCALE DRAWING
 SHEET SCALE: 3:1



520 PARK EAST BLVD., NEW ALBANY, IN 47150
 PHONE: 812-944-6733 FAX: 812-948-5047
 e-Mail: info@SAMTEC.com code 55322

DESCRIPTION: 2.92MM JACK. SOLDER CLAMP FOR SEMFLEX HP160

DWG. NO. PRF92-J-C-EP-160-SS

BY: SAMUEL C 05/06/2019 SHEET 2 OF 3

CABLE APPLICATION VIEWS

A

4A. POINT CABLE CENTER CONDUCTOR AS SHOWN.

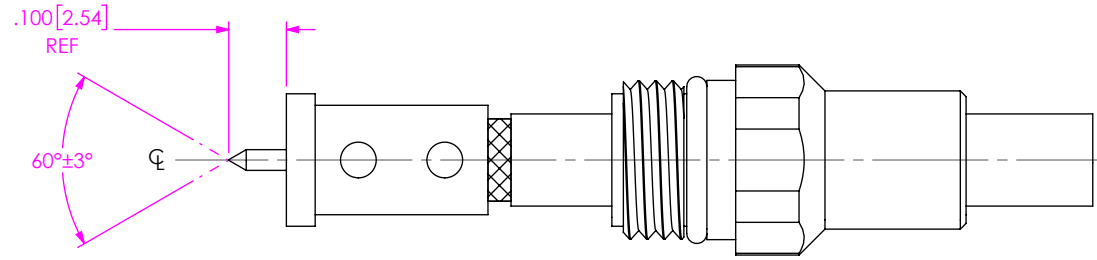

IN-PROCESS VIEW 4

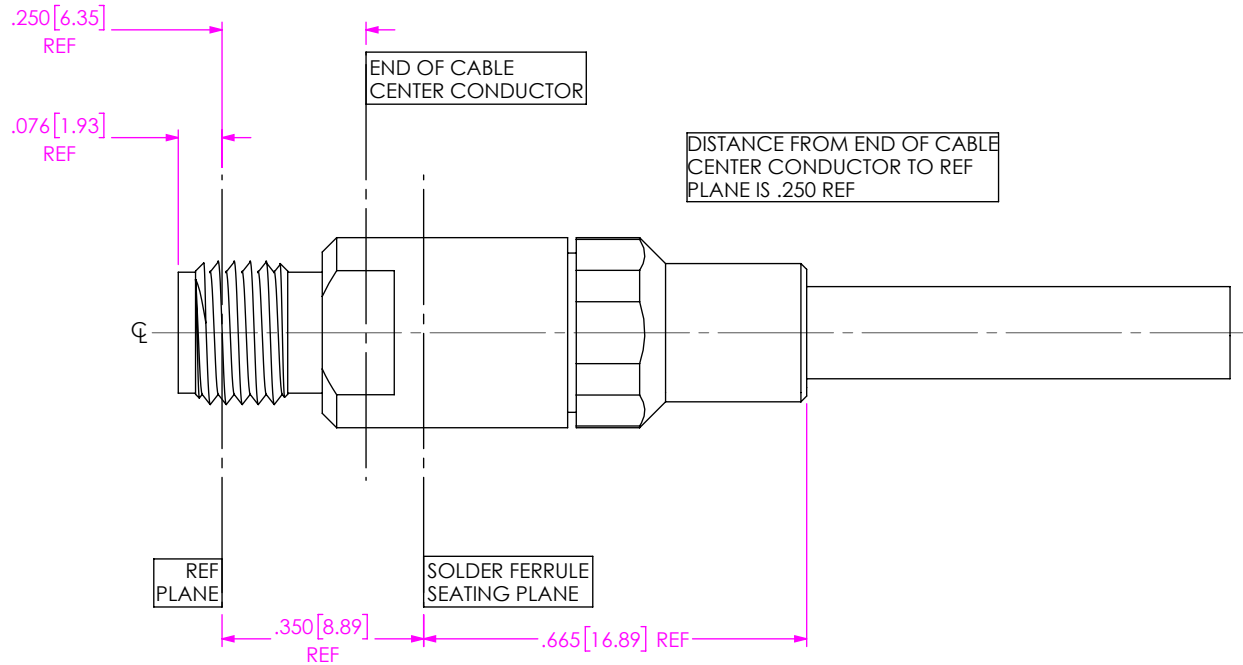

A

5A. INSERT CABLE SUB-ASSEMBLY INTO CONNECTOR UNTIL SEATED AND TIGHTEN CLAMP NUT TO 25-35 IN-LBS.

IN-PROCESS VIEW 5

PROPRIETARY NOTE
 THIS DOCUMENT CONTAINS CONFIDENTIAL AND PROPRIETARY INFORMATION AND ALL DESIGN, MANUFACTURING, REPRODUCTION, USE, PATENT RIGHTS AND SALES RIGHTS ARE EXPRESSLY RESERVED BY SAMTEC, INC. THIS DOCUMENT SHALL NOT BE DISCLOSED, IN WHOLE OR PART, TO ANY UNAUTHORIZED PERSON OR ENTITY NOR REPRODUCED, TRANSFERRED OR INCORPORATED IN ANY OTHER PROJECT IN ANY MANNER WITHOUT THE EXPRESS WRITTEN CONSENT OF SAMTEC, INC.



520 PARK EAST BLVD, NEW ALBANY, IN 47150
 PHONE: 812-944-6733 FAX: 812-948-5047
 e-Mail: info@SAMTEC.com code 55322

DO NOT SCALE DRAWING
 SHEET SCALE: 3:1

DESCRIPTION: 2.92MM JACK. SOLDER CLAMP FOR SEMFLEX HP160

DWG. NO. PRF92-J-C-EP-160-SS

BY: SAMUEL C 05/06/2019 SHEET 3 OF 3