

DO NOT  
SCALE FROM  
THIS PRINT

DESIGNED & DIMENSIONED  
IN INCHES[MILLIMETERS]

PRF92-P-C-EE-405-SD-3

SERIES  
-92: 2.92mm

GENDER  
-P: PLUG

TYPE  
-C: CABLE

FINISH  
-EE: 50μ" EXTRA HEAVY GOLD  
CENTER CONTACT, 50μ" EXTRA  
HEAVY GOLD OUTER CONTACT

OPTION  
-3

TERMINATION  
-D: DIRECT SOLDER

ORIENTATION  
-S: STRAIGHT

CABLE TYPE  
-405: RG-405

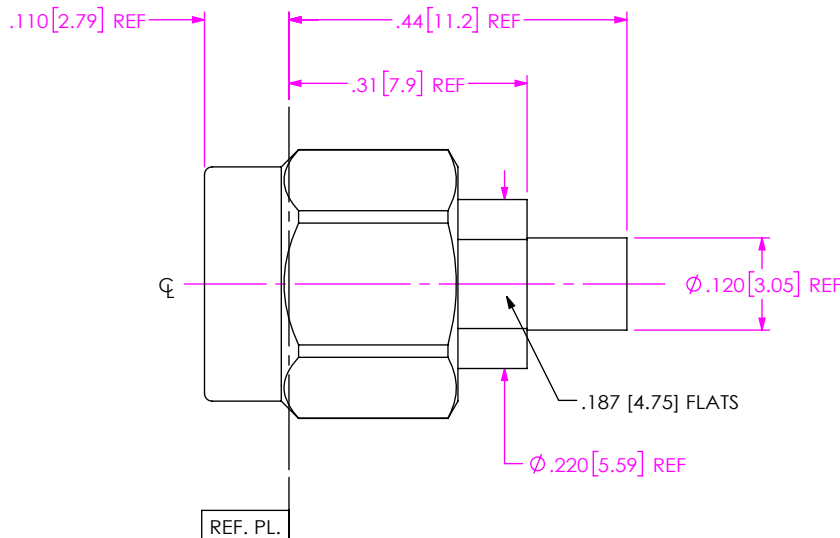
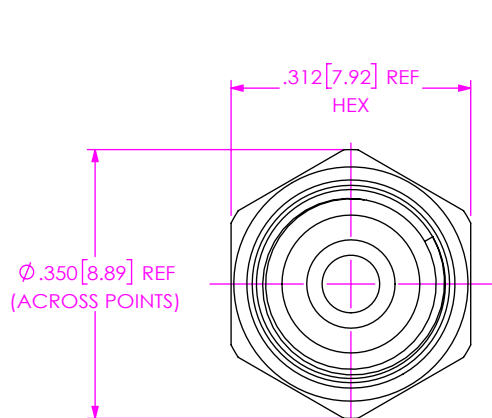

NOTES:

- MATERIAL:  
COUPLING NUT & BUSHING: STAINLESS STEEL.  
BODY & CONTACT, LOCK RING: BERYLLIUM COPPER.  
BEAD: ULTEM 1000.  
GASKET: SILICONE RUBBER.
- FINISH:  
COUPLING NUT & BUSHING: PASSIVATED.  
BODY & CONTACT: GOLD OVER NICKEL PLATE,  
50 MIN GOLD OVER 50 MIN NICKEL.
- PCI P/N: 4121.

c:\enterprisevault\DWG\MISC\MKTG\PRF92-P-C-EE-405-SD-3-MKT.SLDDRW

UNLESS OTHERWISE SPECIFIED, DIMENSIONS ARE IN INCHES. TOLERANCES ARE: DECIMALS      ANGLES .XX: $\pm .02 [0.5]$ 1° .XXX: $\pm .005 [0.13]$ .XXXX: $\pm .0005 [0.013]$	* PROPRIETARY NOTE * THIS DOCUMENT CONTAINS CONFIDENTIAL AND PROPRIETARY INFORMATION AND ALL DESIGN, MANUFACTURING, REPRODUCTION, USE, PATENT RIGHTS AND SALES RIGHTS ARE EXPRESSLY RESERVED BY SAMTEC, INC. THIS DOCUMENT SHALL NOT BE DISCLOSED, IN WHOLE OR PART, TO ANY UNAUTHORIZED PERSON OR ENTITY NOR REPRODUCED, TRANSFERRED OR INCORPORATED IN ANY OTHER PROJECT IN ANY MANNER WITHOUT THE EXPRESS WRITTEN CONSENT OF SAMTEC, INC.	 520 PARK EAST BLVD., NEW ALBANY, IN 47150 PHONE: 812-944-6733      FAX: 812-948-5047 e-Mail: info@SAMTEC.com      code 55322	
		DO NOT SCALE DRAWING      SHEET SCALE: 4:1	DESCRIPTION: 2.92MM PLUG, DIRECT SOLDER FOR RG-405 CABLE
		DWG. NO. PRF92-P-C-EE-405-SD-3	BY: EVE L      02/05/2021      SHEET 1 OF 2

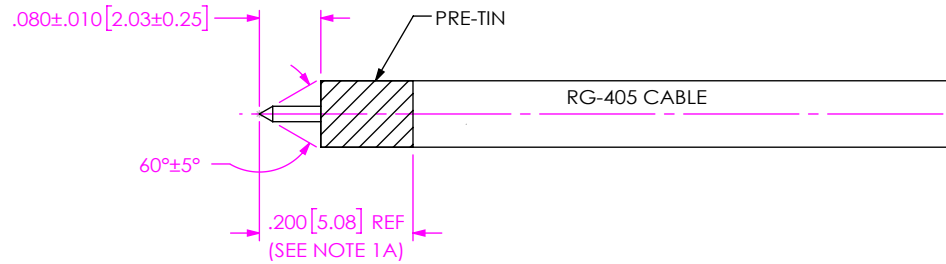

- 1A. PRE-TIN CABLE OUTER JACKET OVER APPROX. LENGTH SHOWN.
- 1B. TRIM CABLE TO EXPOSE CENTER CONDUCTOR AS SHOWN.
- 1C. POINT CENTER CONDUCTOR AS INDICATED.

IN-PROCESS 1

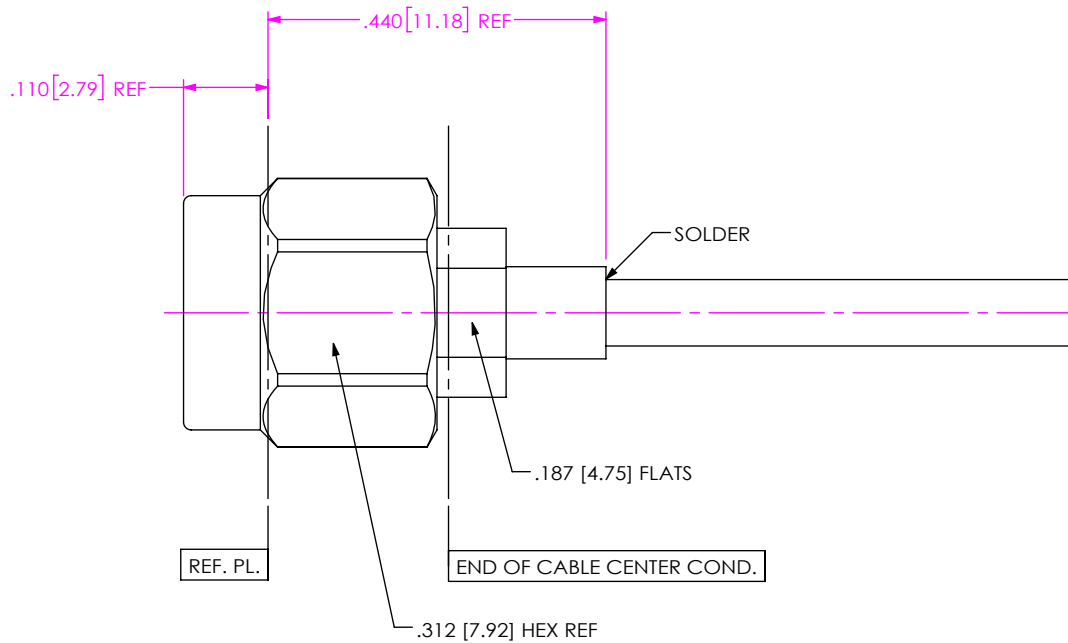

- 2A. INSERT CABLE INTO CONNECTOR UNTIL CENTER CONDUCTOR PLUGS IN AND CABLE SEATS IN CONNECTOR BORE.
- 2B. SOLDER CABLE JACKET TO BODY WHERE SHOWN APPLYING HEAT TO EXTENDED BODY TAIL.

IN-PROCESS 2

<p>DO NOT SCALE DRAWING</p> <p>SHEET SCALE: 4:1</p>	<p><b>PROPRIETARY NOTE</b></p> <p>THIS DOCUMENT CONTAINS CONFIDENTIAL AND PROPRIETARY INFORMATION AND ALL DESIGN, MANUFACTURING, REPRODUCTION, USE, PATENT RIGHTS AND SALES RIGHTS ARE EXPRESSLY RESERVED BY SAMTEC, INC. THIS DOCUMENT SHALL NOT BE DISCLOSED, IN WHOLE OR PART, TO ANY UNAUTHORIZED PERSON OR ENTITY NOR REPRODUCED, TRANSFERRED OR INCORPORATED IN ANY OTHER PROJECT IN ANY MANNER WITHOUT THE EXPRESS WRITTEN CONSENT OF SAMTEC, INC.</p>		 <p>520 PARK EAST BLVD, NEW ALBANY, IN 47150                  PHONE: 812-944-6733 FAX: 812-948-5047                  e-Mail info@SAMTEC.com code 55322</p>
	<p>DESCRIPTION: 2.92MM PLUG, DIRECT SOLDER FOR RG-405 CABLE</p>		
	<p>DWG. NO. PRF92-P-C-EE-405-SD-3</p>		
<p>BY: EVE L</p>		<p>02/05/2021</p>	<p>SHEET 2 OF 2</p>