

DO NOT SCALE FROM THIS PRINT

DESIGNED & DIMENSIONED IN INCHES[MILLIMETERS]

PRF92-P-C-EE-405-SD

SERIES
-92: 2.92mm

GENDER
-P: PLUG

TYPE
-C: CABLE

FINISH
-EE: 50µ" EXTRA HEAVY GOLD CENTER CONTACT, 50µ" EXTRA HEAVY GOLD OUTER CONTACT

TERMINATION
-D: DIRECT SOLDER

ORIENTATION
-S: STRAIGHT

CABLE TYPE
-405: RG-405 SEMI-RIGID

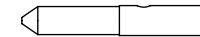
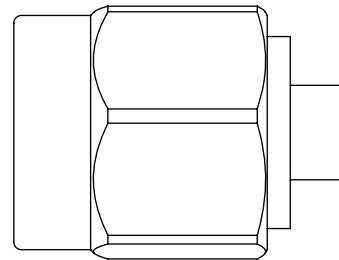
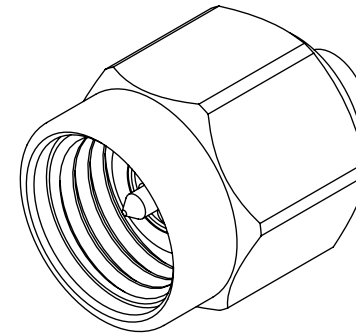
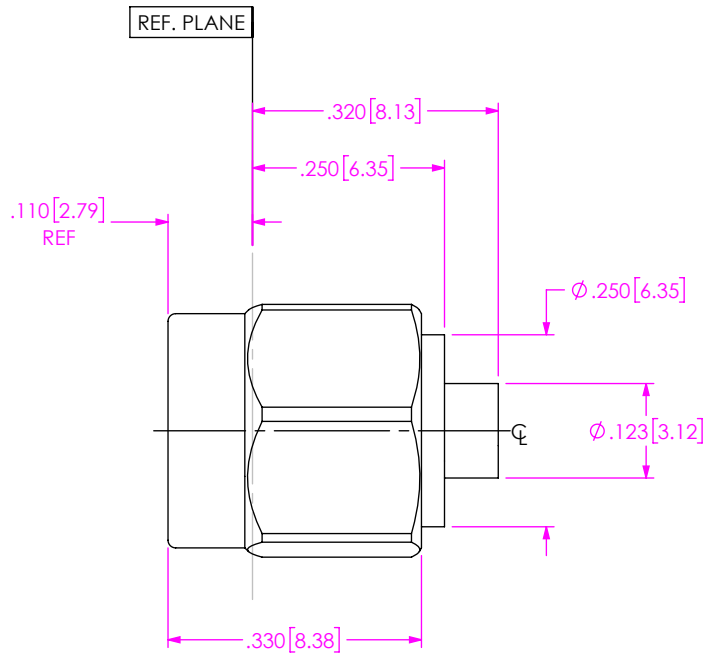

EXPLODED VIEW
NOT TO SCALE
(FOR CLARITY ONLY)

1. MATERIAL:

BODY, COUPLING NUT: STAINLESS STEEL
CONTACT, LOCK RING: BERYLLIUM COPPER
BEAD: PPE
GASKET: SILICONE RUBBER

2. FINISH:

COUPLING NUT: PASSIVATED
BODY, CONTACT: 50µ" MIN. GOLD OVER 50µ" MIN. NICKEL PLATE

3. PCI P/N: 3146

F:\DWG\MISC\MKTG\PRF92-P-C-EE-405-SD-MKT.SLDDRW

UNLESS OTHERWISE SPECIFIED, DIMENSIONS ARE IN INCHES. TOLERANCES ARE: DECIMALS ANGLES .XX: ±.01 [0.3] 1° .XXX: ±.005 [0.13] .XXXX: ±.0005 [0.013]	* PROPRIETARY NOTE * THIS DOCUMENT CONTAINS CONFIDENTIAL AND PROPRIETARY INFORMATION AND ALL DESIGN, MANUFACTURING, REPRODUCTION, USE, PATENT RIGHTS AND SALES RIGHTS ARE EXPRESSLY RESERVED BY SAMTEC, INC. THIS DOCUMENT SHALL NOT BE DISCLOSED, IN WHOLE OR PART, TO ANY UNAUTHORIZED PERSON OR ENTITY NOR REPRODUCED, TRANSFERRED OR INCORPORATED IN ANY OTHER PROJECT IN ANY MANNER WITHOUT THE EXPRESS WRITTEN CONSENT OF SAMTEC, INC.		
		520 PARK EAST BLVD., NEW ALBANY, IN 47150 PHONE: 812-944-6733 FAX: 812-948-5047 e-Mail: info@SAMTEC.com code 55322	
		DO NOT SCALE DRAWING	SHEET SCALE: 4:1
		BY: SHERRY W 2/1/2019	SHEET 1 OF 4

CABLE APPLICATION VIEWS

PART NUMBER WAS 1-000-2085-2

- 1A. TRIM CABLE JACKET & DIELECTRIC TO EXPOSE CENTER CONDUCTOR AS SHOWN (DO NOT NICK CENTER CONDUCTOR).
- 1B. PRE-TIN CABLE JACKET TO THE APPROXIMATE LENGTH SHOWN.

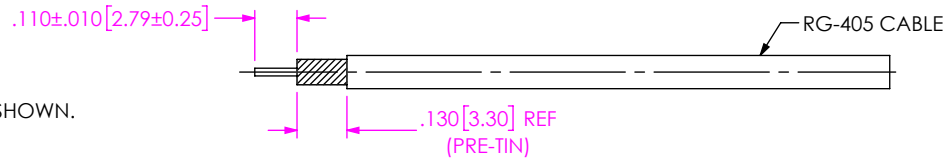

IN-PROCESS VIEW 1

- 2A. PRE-TIN CABLE CENTER CONDUCTOR AND SOLDER ON CONTACT WITH GAP SHOWN.

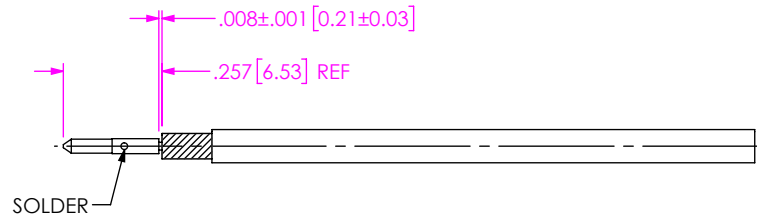

IN-PROCESS VIEW 2

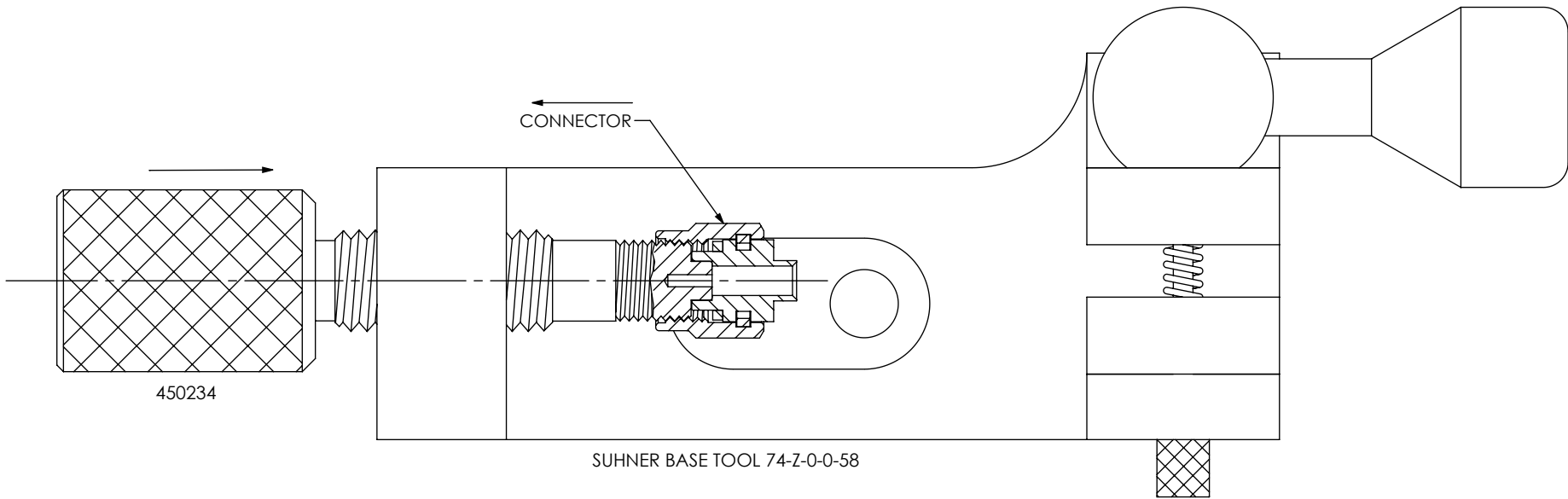

- 3A. THREAD PCI ASSEMBLY TOOL 450234 INTO SUHNER BASE. THEN THREAD CONNECTOR BODY ONTO PCI TOOL UNTIL SEATED.

IN-PROCESS VIEW 3

PROPRIETARY NOTE
 THIS DOCUMENT CONTAINS CONFIDENTIAL AND PROPRIETARY INFORMATION AND ALL DESIGN, MANUFACTURING, REPRODUCTION, USE, PATENT RIGHTS AND SALES RIGHTS ARE EXPRESSLY RESERVED BY SAMTEC, INC. THIS DOCUMENT SHALL NOT BE DISCLOSED, IN WHOLE OR PART, TO ANY UNAUTHORIZED PERSON OR ENTITY NOR REPRODUCED, TRANSFERRED OR INCORPORATED IN ANY OTHER PROJECT IN ANY MANNER WITHOUT THE EXPRESS WRITTEN CONSENT OF SAMTEC, INC.



520 PARK EAST BLVD, NEW ALBANY, IN 47150
 PHONE: 812-944-6733 FAX: 812-948-5047
 e-Mail: info@SAMTEC.com code 55322

DO NOT SCALE DRAWING
 SHEET SCALE: 2:1

DESCRIPTION: 2.92 MM PLUG ASSEMBLY

DWG. NO. PRF92-P-C-EE-405-SD

BY: SHERRY W 2/1/2019 SHEET 2 OF 4

CABLE APPLICATION VIEWS

4A. SLIDE PREPARED CABLE THROUGH CABLE CLAMP BLOCKS AND INSERT CABLE INTO CONNECTOR BACK END UNTIL FULLY SEATED. THEN LOCK CABLE IN PLACE BY ROTATING LEVER ARM.

4B. HEAT CONNECTOR BODY BACK END AND REFLOW SOLDER CABLE TO CONNECTOR.
 4C. FLOW ADDITIONAL SOLDER AT REAR OF BODY WHERE INDICATED IF NECESSARY.

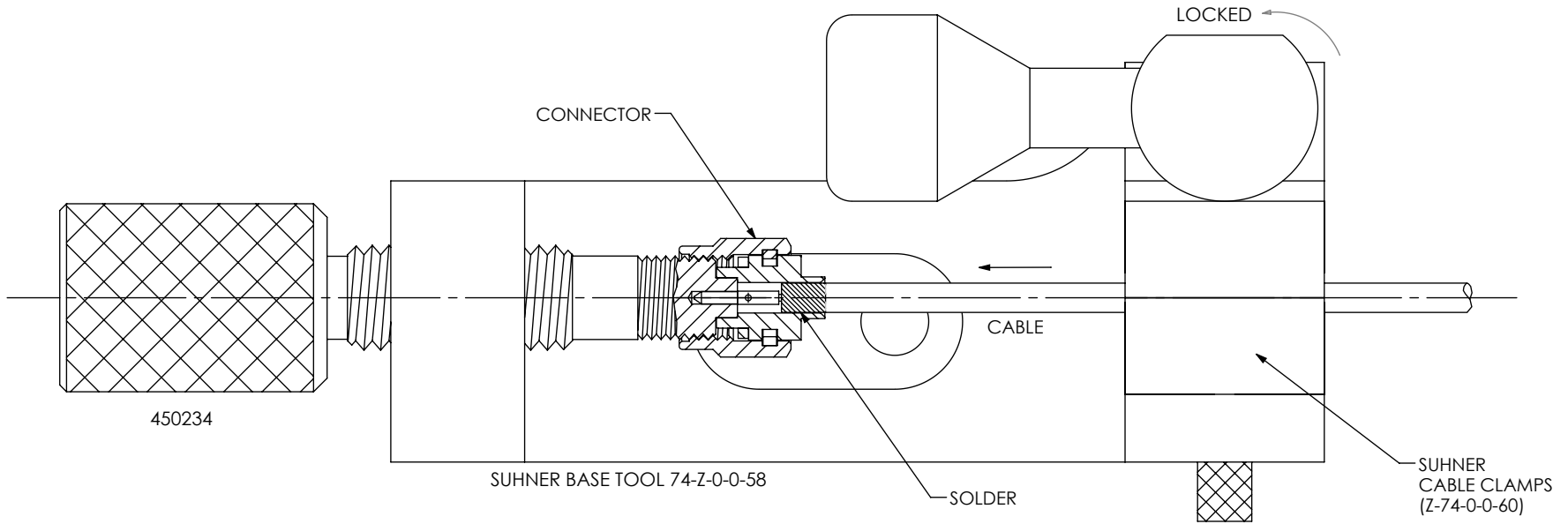

IN-PROCESS VIEW 4

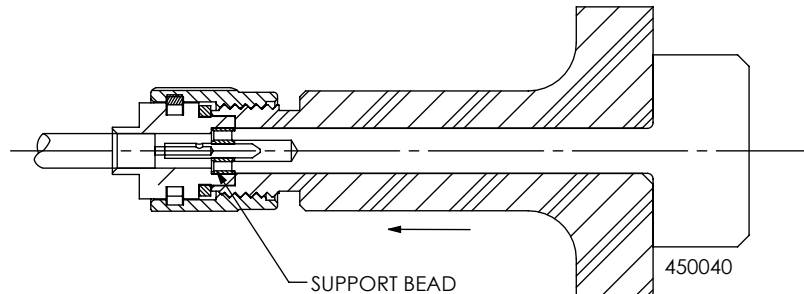

5. REMOVE CONNECTOR FROM SUHNER BASE TOOL AND INSTALL DIELECTRIC SUPPORT BEAD USING PCI TOOL SET 450040

IN-PROCESS VIEW 5

F:\DWG\MISC\MKTG\PRF92-P-C-EE-405-SD-MKT.SLDDRW

PROPRIETARY NOTE
 THIS DOCUMENT CONTAINS CONFIDENTIAL AND PROPRIETARY INFORMATION AND ALL DESIGN, MANUFACTURING, REPRODUCTION, USE, PATENT RIGHTS AND SALES RIGHTS ARE EXPRESSLY RESERVED BY SAMTEC, INC. THIS DOCUMENT SHALL NOT BE DISCLOSED, IN WHOLE OR PART, TO ANY UNAUTHORIZED PERSON OR ENTITY NOR REPRODUCED, TRANSFERRED OR INCORPORATED IN ANY OTHER PROJECT IN ANY MANNER WITHOUT THE EXPRESS WRITTEN CONSENT OF SAMTEC, INC.



520 PARK EAST BLVD, NEW ALBANY, IN 47150
 PHONE: 812-944-6733 FAX: 812-948-5047
 e-Mail: info@SAMTEC.com code 55322

DO NOT SCALE DRAWING

SHEET SCALE: 2:1

DESCRIPTION:
 2.92 MM PLUG ASSEMBLY

DWG. NO. PRF92-P-C-EE-405-SD

BY: SHERRY W 2/1/2019 SHEET 3 OF 4

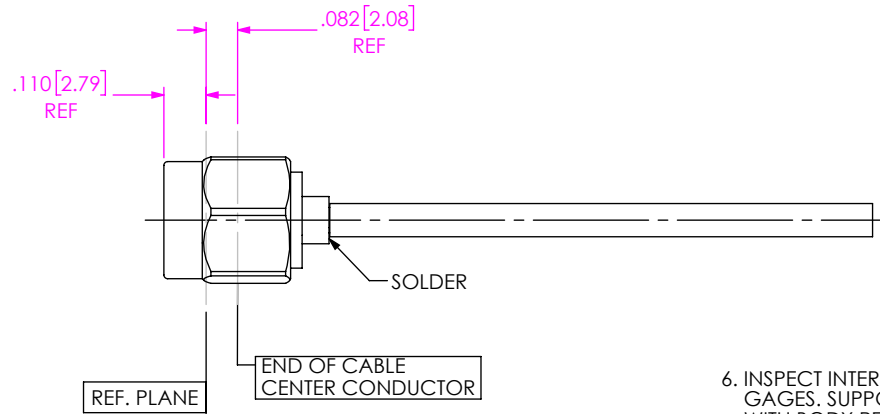

6. INSPECT INTERFACE INSULATION RECESSON USING THE APPROPRIATE GAGES. SUPPORT BEAD INNER AND OUTER SURFACES TO BE SUB-FLUSH WITH BODY REFERENCE PLANE.

IN-PROCESS VIEW 6

PROPRIETARY NOTE
 THIS DOCUMENT CONTAINS CONFIDENTIAL AND PROPRIETARY INFORMATION AND ALL DESIGN, MANUFACTURING, REPRODUCTION, USE, PATENT RIGHTS AND SALES RIGHTS ARE EXPRESSLY RESERVED BY SAMTEC, INC. THIS DOCUMENT SHALL NOT BE DISCLOSED, IN WHOLE OR PART, TO ANY UNAUTHORIZED PERSON OR ENTITY NOR REPRODUCED, TRANSFERRED OR INCORPORATED IN ANY OTHER PROJECT IN ANY MANNER WITHOUT THE EXPRESS WRITTEN CONSENT OF SAMTEC, INC.



520 PARK EAST BLVD, NEW ALBANY, IN 47150
 PHONE: 812-944-6733 FAX: 812-948-5047
 e-Mail info@SAMTEC.com code 55322

DO NOT SCALE DRAWING

SHEET SCALE: 2:1

DESCRIPTION: 2.92 MM PLUG ASSEMBLY

DWG. NO. PRF92-P-C-EE-405-SD

BY: SHERRY W 2/1/2019 SHEET 4 OF 4