

DO NOT SCALE FROM THIS PRINT

DESIGNED & DIMENSIONED IN INCHES [MILLIMETERS]

PRFIA-SMPM-J-J-SP-2

SERIES  
-M0: SMPM

GENDER  
-J: JACK

GENDER  
-J: JACK

OPTION  
-2

ORIENTATION  
-SP: SPRING LOADED

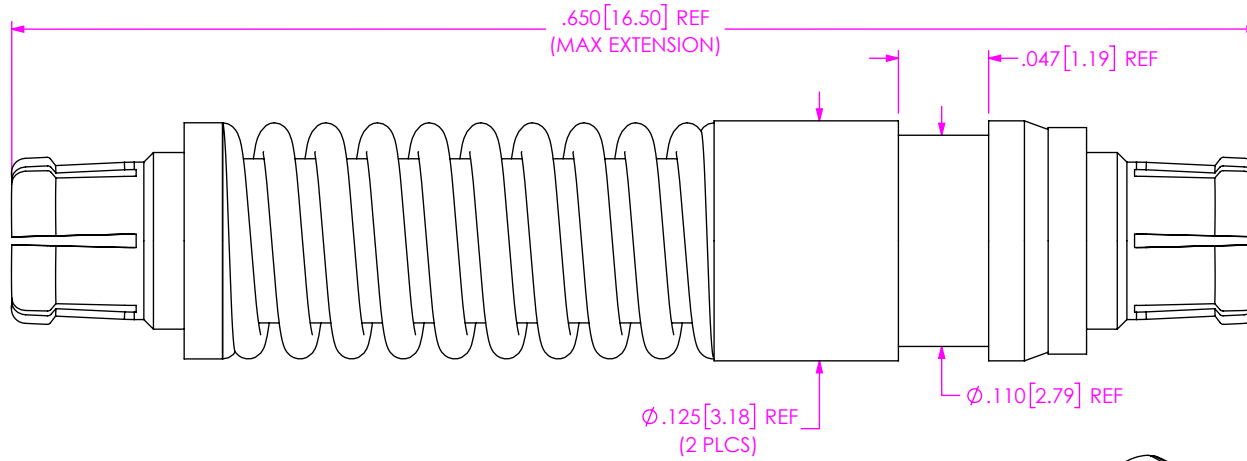

FIG 1  
PRFIA-SMPM-J-J-SP-2 SHOWN

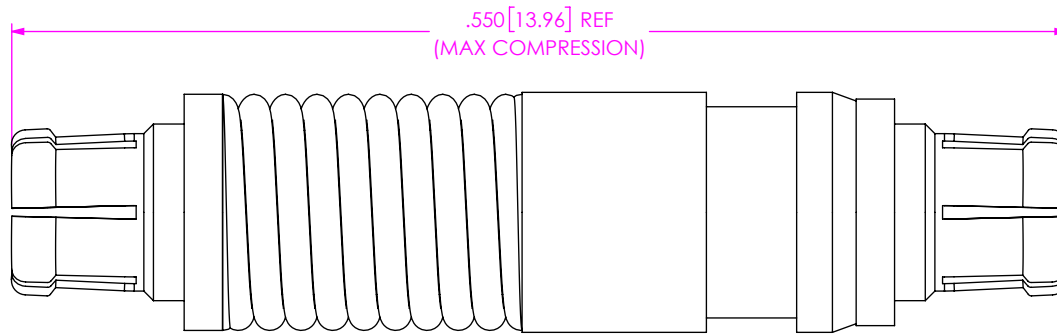
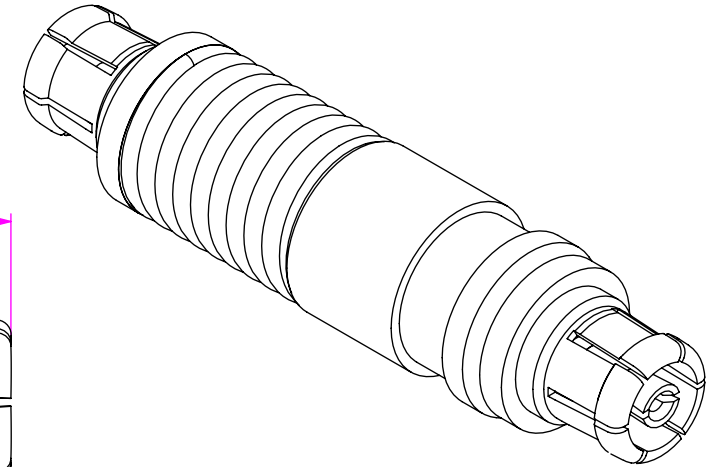

FIG 2  
PRFIA-SMPM-J-J-SP-2 SHOWN



- NOTES:
1. TRAYS TO BE STANDARD PACKAGING.
  2. MATERIAL:  
BODY, CONTACT: BERYLLIUM COPPER.  
BEAD: PTFE.
  3. FINISH:  
BODY, CONTACT: GOLD OVER NICKEL PLATE,  
50  $\mu$ IN MIN GOLD OVER 50  $\mu$ IN MIN NICKEL.

UNLESS OTHERWISE SPECIFIED,  
DIMENSIONS ARE IN INCHES.  
TOLERANCES ARE:  
DECIMALS            ANGLES  
.XX:  $\pm .01 [0.3]$             2°  
.XXX:  $\pm .005 [0.13]$   
.XXXX:  $\pm .0005 [0.013]$

**PROPRIETARY NOTE**  
THIS DOCUMENT CONTAINS CONFIDENTIAL AND PROPRIETARY INFORMATION AND ALL DESIGN, MANUFACTURING, REPRODUCTION, USE, PATENT RIGHTS AND SALES RIGHTS ARE EXPRESSLY RESERVED BY SAMTEC, INC. THIS DOCUMENT SHALL NOT BE DISCLOSED, IN WHOLE OR PART, TO ANY UNAUTHORIZED PERSON OR ENTITY NOR REPRODUCED, TRANSFERRED OR INCORPORATED IN ANY OTHER PROJECT IN ANY MANNER WITHOUT THE EXPRESS WRITTEN CONSENT OF SAMTEC, INC.



520 PARK EAST BLVD., NEW ALBANY, IN 47150  
PHONE: 812-944-6733    FAX: 812-948-5047  
e-Mail: info@SAMTEC.com    code 55322

DO NOT SCALE DRAWING

SHEET SCALE: 10:1

DESCRIPTION:  
.650 SMPM BULLET JACK ASSEMBLY

DWG. NO.  
PRFIA-SMPM-J-J-SP-2

BY: MATT M            7/26/2021            SHEET 1 OF 1