

DO NOT SCALE FROM THIS PRINT

DESIGNED & DIMENSIONED IN MILLIMETERS[INCHES]

QSFPK-PF-XX

PRESS FIT

OPTION

- 01: WITHOUT HEAT SINK (USE QSFPK-PF-01 & QSFP8-038-01-L-D-RA1 ONE EACH)
- 02: WITH HEAT SINK ASSEMBLED (SEE NOTE 4) (USE QSFPK-PF-02, QSFP8-038-01-L-D-RA1, HS-100-01 & SH58-01 ONE EACH)
- 03: WITH HEAT SINK IN A KIT (USE QSFPK-PF-02, QSFP8-038-01-L-D-RA1, HS-100-01, & SH58-01 ONE EACH)

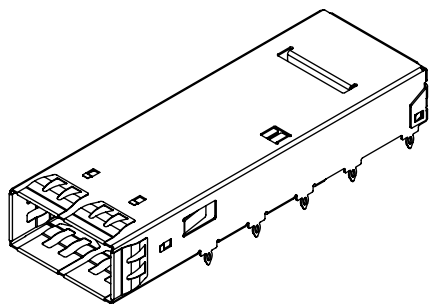

QSFPK-PF-01

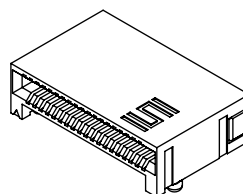

QSFP8-038-01-L-D-RA1

FIG 1 (QSFPK-PF-01 SHOWN)

TABLE 1		
STYLE	PART NUMBER	QUANTITY
QSFPK-PF-01	QSFPK-PF-01	1.000
	QSFP8-038-01-L-D-RA1	1.000
	PT-1-24-02-44	0.033
	TP-03	0.066
	PT-RPB1001	0.110
QSFPK-PF-02	TP-04	0.220
	QSFPK-PF-02	1.000
	QSFP8-038-01-L-D-RA1	1.000
	PT-1-24-02-44	0.033
	TP-03	0.066
QSFPK-PF-03	PT-RPB1001	0.110
	TP-04	0.220
	QSFPK-PF-03	1.000
	QSFP8-038-01-L-D-RA1	1.000
	HS-100-01	1.000
	SH58-01	1.000
	PT-1-24-02-44	0.033
	TP-03	0.232
	PT-RPB1001	0.110
	TP-04	0.220
	PT-1-24-14-29	0.083
	PT-1-24-01-34	0.045
	TP-07	0.090

PACKAGING VIEW FOR CONNECTOR (SEE NOTE 3)

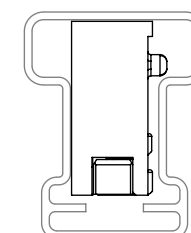

TUBE: PT-1-24-02-44
PLUG: TP-03

NOTES:

1. Ⓢ REPRESENTS A CRITICAL DIMENSION.
2. MINIMUM PUSHOUT FORCE: 1.11N[0.25 LB].
3. OPTIONS -01 & -02 MUST BE PACKAGE IN TRAYS, FOR OPTION -03 CAGE MUST BE PACKAGED IN TRAYS, HEAT SINK AND SHIELD MUST BE PACKAGED IN TUBES
4. HEAT SINK MUST BE REMOVED PRIOR TO TERMINATION TO PRINTED CIRCUIT BOARD.
5. SEE QSFPK-PF APPLICATION FOR ADDITIONAL TERMINATION INSTRUCTIONS.

UNLESS OTHERWISE SPECIFIED, DIMENSIONS ARE IN MILLIMETERS.
TOLERANCES ARE:
DECIMALS ANGLES
X.X: ±0.3 [.01] 2°
X.XX: ±0.13 [.005]
X.XXX: ±0.051 [.0020]

PROPRIETARY NOTE

THIS DOCUMENT CONTAINS INFORMATION CONFIDENTIAL AND PROPRIETARY TO SAMTEC, INC. AND SHALL NOT BE REPRODUCED OR TRANSFERRED TO OTHER DOCUMENTS OR DISCLOSED TO OTHERS OR USED FOR ANY PURPOSE OTHER THAN THAT WHICH IT WAS OBTAINED WITHOUT THE EXPRESSED WRITTEN CONSENT OF SAMTEC, INC.

MATERIAL: DO NOT SCALE DRAWING SHEET SCALE: 1:5:1

INSULATOR: LCP
CONTACT: PHOS BRONZE
SHIELD: PHOS BRONZE & SUS 304
HEAT SINK: ALUMINUM-ALLOY



520 PARK EAST BLVD., NEW ALBANY, IN 47150
PHONE: 812-944-6733 FAX: 812-948-5047
e-Mail: info@SAMTEC.com code 53322

DESCRIPTION:	QSFP ASM
DWG. NO.	QSFPK-PF-XX
BY:	ROY LUO 7/5/2010 SHEET 1 OF 3

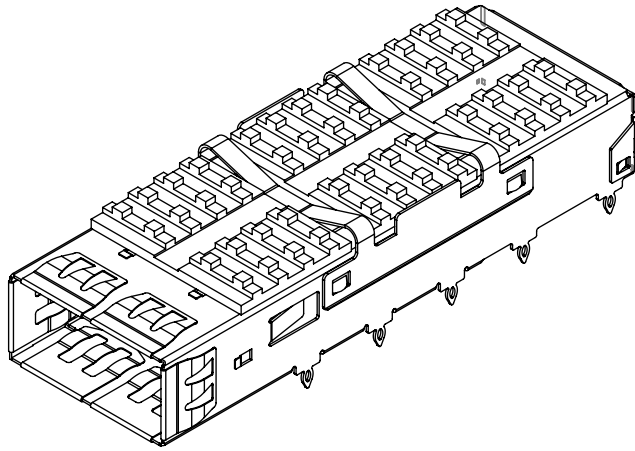

QSFPC-PF-02

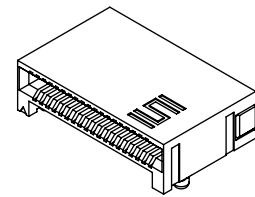

QSFP8-038-01-L-D-RA1

FIG 2
(QSFPK-PF-02 SHOWN)
(SAME AS FIG. 1, EXCEPT AS SHOWN)

PACKAGING VIEW FOR CONNECTOR
(SEE NOTE 3)

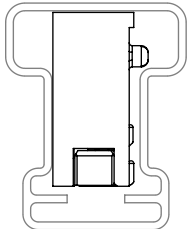

TUBE: PT-1-24-02-44
PLUG: TP-03

PROPRIETARY NOTE
THIS DOCUMENT CONTAINS INFORMATION
CONFIDENTIAL AND PROPRIETARY TO
SAMTEC, INC. AND SHALL NOT BE REPRODUCED
OR TRANSFERRED TO OTHER DOCUMENTS OR
DISCLOSED TO OTHERS OR USED FOR ANY
PURPOSE OTHER THAN THAT WHICH IT WAS
OBTAINED WITHOUT THE EXPRESSED WRITTEN
CONSENT OF SAMTEC, INC.

DO NOT SCALE DRAWING

SHEET SCALE: 1.5:1



520 PARK EAST BLVD, NEW ALBANY, IN 47150
PHONE: 812-944-6733 FAX: 812-948-5047
e-Mail info@SAMTEC.com code 55322

DESCRIPTION:	QSFP ASM
DWG. NO.	QSFPK-PF-XX
BY: ROY LUO	7/5/2010
SHEET 2 OF 3	

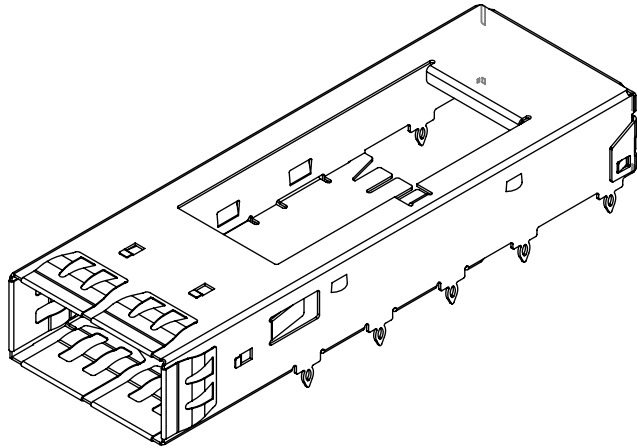

QSFP-PF-03

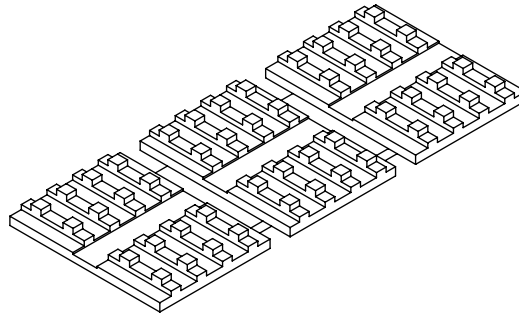

HS-100-01

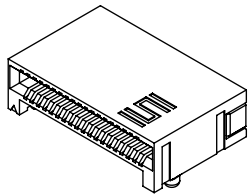

QSFP8-038-01-L-D-RA1

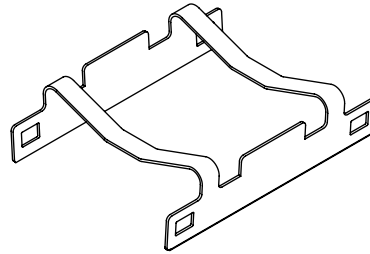

SH58-01

FIG 3
(QSFPK-PF-03 SHOWN)
(SAME AS FIG. 1, EXCEPT AS SHOWN)

PACKAGING VIEW FOR CONNECTOR
(SEE NOTE 3)

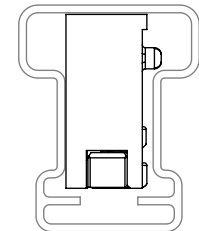

TUBE: PT-1-24-02-44
PLUG: TP-03

PACKAGING VIEW FOR SHIELD
(SEE NOTE 3)

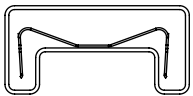

TUBE: PT-1-24-01-34
PLUG: TP-07

PACKAGING VIEW FOR HEAT SINK
(SEE NOTE 3)

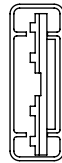

TUBE: PT-1-24-14-29
PLUG: TP-03

PROPRIETARY NOTE

THIS DOCUMENT CONTAINS INFORMATION CONFIDENTIAL AND PROPRIETARY TO SAMTEC, INC. AND SHALL NOT BE REPRODUCED OR TRANSFERRED TO OTHER DOCUMENTS OR DISCLOSED TO OTHERS OR USED FOR ANY PURPOSE OTHER THAN THAT WHICH IT WAS OBTAINED WITHOUT THE EXPRESSED WRITTEN CONSENT OF SAMTEC, INC.

DO NOT SCALE DRAWING

SHEET SCALE: 1.5:1



520 PARK EAST BLVD, NEW ALBANY, IN 47150
PHONE: 812-944-6733 FAX: 812-948-5047
e-Mail: info@SAMTEC.com code 55322

DESCRIPTION:

QSFP ASM

DWG. NO.

QSFPK-PF-XX

BY: ROY LUO 7/5/2010

SHEET 3 OF 3