

DO NOT SCALE FROM THIS PRINT

BOM TABLE				
ITEM	PART NUMBER	SMA STYLE	STACK HEIGHT	DESCRIPTION
1	S-REF-231562-1.85-01	1.85	-01	EVALUATION KIT
	S-REF-231562-1.85-02		-02	
	S-REF-231562-2.40-01	2.40	-01	
	S-REF-231562-2.40-02		-02	
	S-REF-231562-2.92-01	2.92	-01	
	S-REF-231562-2.92-02		-02	

**STACK HEIGHT**  
 \*-01: 8.5 mm  
 -02: 10 mm

**SMA STYLE**  
 -1.85: 1.85mm SMAS  
 -2.40: 2.40mm SMAS  
 -2.92: 2.92mm SMAS

(\* - NOT TOOLED)

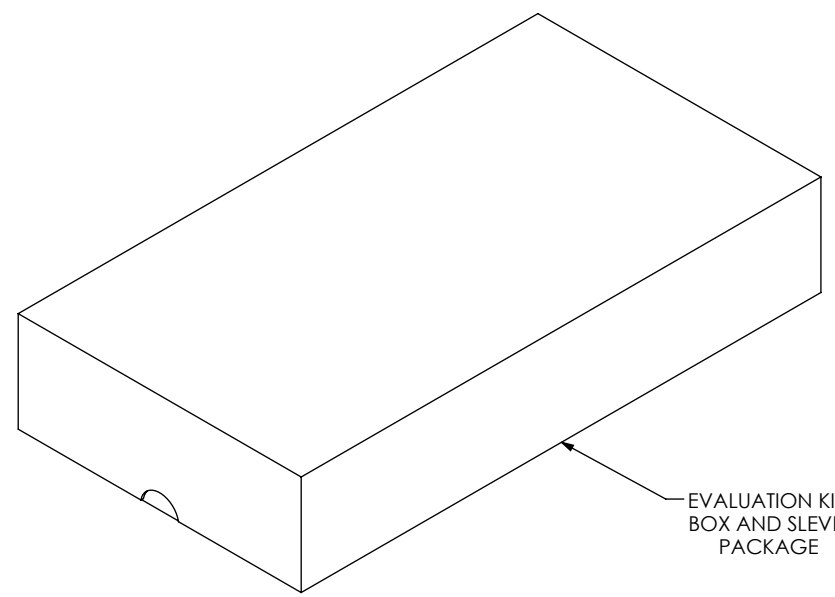
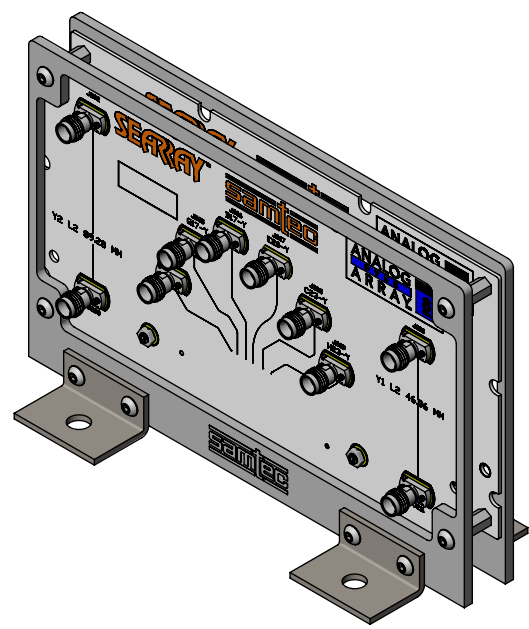

TOLERANCES DO NOT APPLY TO REFERENCE DIMENSIONS, UNLESS OTHERWISE SPECIFIED, DIMENSIONS ARE IN INCHES. TOLERANCES ARE: DECIMALS      ANGLES .XX: ±.01 [.3]      2° .XXX: ±.005 [.13] .XXXX: ±.0020 [.051]	* PROPRIETARY NOTE * THIS DOCUMENT CONTAINS CONFIDENTIAL AND PROPRIETARY INFORMATION AND ALL DESIGN, MANUFACTURING, REPRODUCTION, USE, PATENT RIGHTS AND SALES RIGHTS ARE EXPRESSLY RESERVED BY SAMTEC, INC. THIS DOCUMENT SHALL NOT BE DISCLOSED, IN WHOLE OR PART, TO ANY UNAUTHORIZED PERSON OR ENTITY NOR REPRODUCED, TRANSFERRED OR INCORPORATED IN ANY OTHER PROJECT IN ANY MANNER WITHOUT THE EXPRESS WRITTEN CONSENT OF SAMTEC, INC.	 520 PARK EAST BLVD, NEW ALBANY, IN 47150 PHONE: 812-944-6733    FAX: 812-948-5047 e-Mail: info@SAMTEC.com    code 55322	
		DO NOT SCALE DRAWING      SHEET SCALE: 1:8	DESCRIPTION: SEAX ANALOG EVALUATION KIT
		MATERIAL:	DWG. NO. REF-231562-X.XX-XX BY:CHRISTIAN S.    05/29/2024    SHEET 1 OF 1