

DO NOT SCALE FROM THIS PRINT

REF-246550-X.XX-XX

SMA STYLE
 -1.00: 1.00mm SMAS **
 -1.85: 1.85mm SMAS

CONFIGURATION
 -01: 12 IN CABLE

** NOT TOOLED

DESIGNED AND DIMENSIONED IN MILLIMETERS [INCHES] ALL DIMENSIONS REFERENCE EXCEPT AS SHOWN

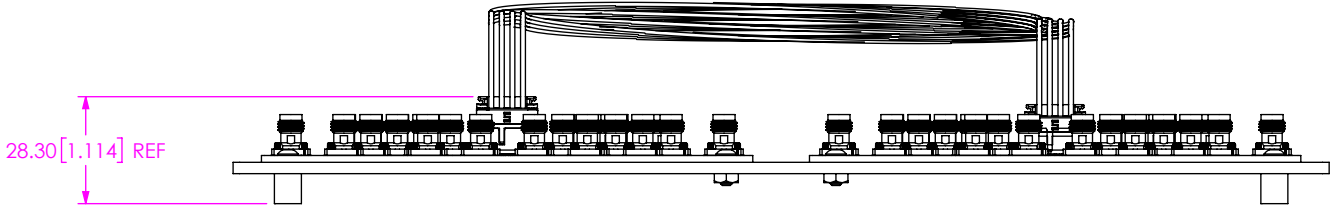
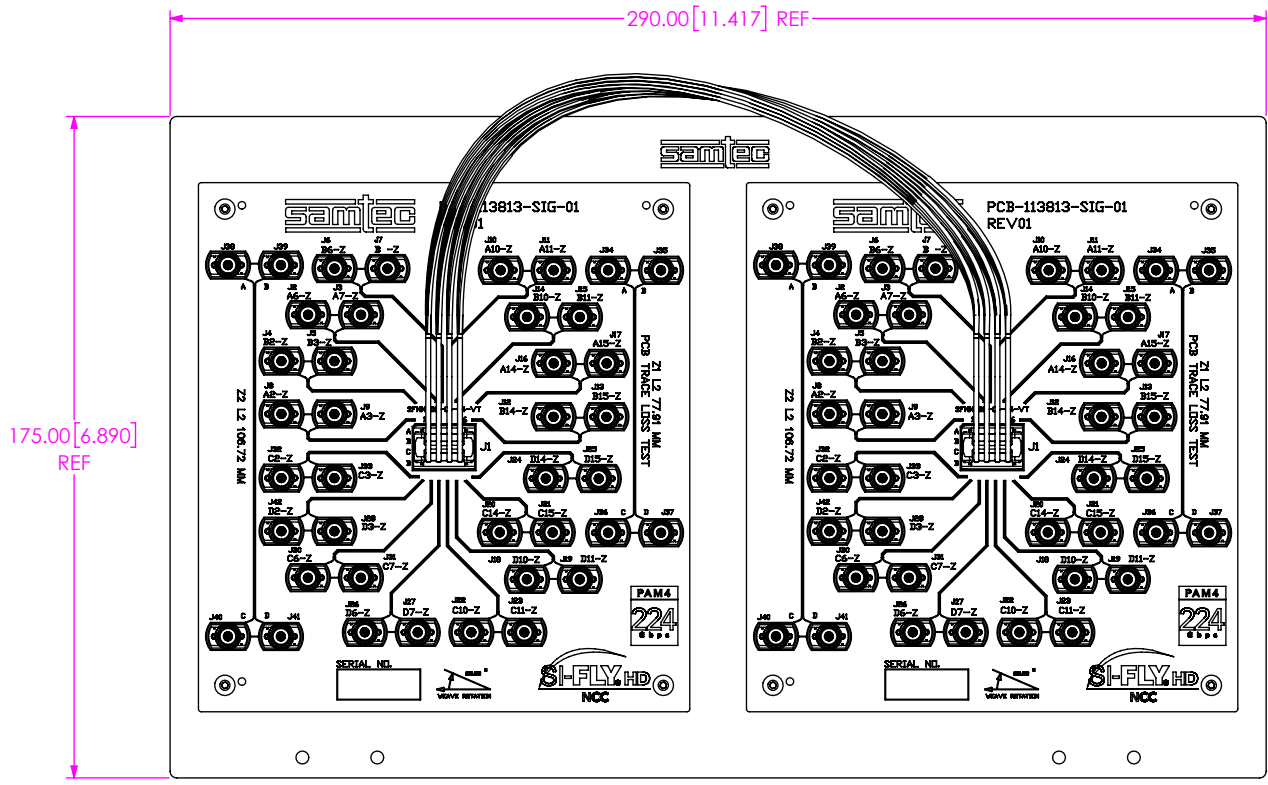

		SIGNAL MAPPING																															
SFNM	REF DES	J2	J3	J4	J5	J6	J7	J8	J9	J10	J11	J12	J13	J14	J15	J16	J17	J18	J19	J20	J21	J22	J23	J24	J25	J26	J27	J28	J29	J30	J31	J32	J33
	CONNECTOR PIN	A6	A7	B2	B3	B6	B7	A2	A3	A10	A11	B14	B15	B10	B11	A14	A15	D10	D11	C14	C15	C10	C11	D14	D15	D6	D7	D3	D2	C6	C7	C2	C3
SFNM	CONNECTOR PIN	A11	A10	B15	B14	B11	B10	A15	A14	A7	A6	B3	B2	B7	B6	A3	A2	D7	D6	C3	C2	C7	C6	D3	D2	D11	D10	D14	D15	C11	C10	C15	C14
	REF DES	J11	J10	J13	J12	J15	J14	J17	J16	J3	J2	J5	J4	J7	J6	A14	J8	J27	J26	J33	J32	J31	J30	J28	J29	J19	J18	J24	J25	J23	J22	J21	J20

BOM TABLE				
ITEM	RF CONFIGURATION	QTY	COST QTY	ITEM
1	1.00**	1	1	S-REF-246550-1.00-01
	1.85	1	1	S-REF-246550-1.85-01

** NOT TOOLED

NOTES:
 1. KIT INCLUDES 2X FRAMED EVALUATION PCBA AND 1X 12 IN CABLE.

PROPRIETARY NOTE
 THIS DOCUMENT CONTAINS CONFIDENTIAL AND PROPRIETARY INFORMATION AND ALL DESIGN, MANUFACTURING, REPRODUCTION, USE, PATENT RIGHTS AND SALES RIGHTS ARE EXPRESSLY RESERVED BY SAMTEC, INC. THIS DOCUMENT SHALL NOT BE DISCLOSED, IN WHOLE OR PART, TO ANY UNAUTHORIZED PERSON OR ENTITY NOR REPRODUCED, TRANSFERRED OR INCORPORATED IN ANY OTHER PROJECT IN ANY MANNER WITHOUT THE EXPRESS WRITTEN CONSENT OF SAMTEC, INC.



520 PARK EAST BLVD, NEW ALBANY, IN 47150
 PHONE: 812-944-6733 FAX: 812-948-5047
 e-Mail: info@SAMTEC.com code 53322

DO NOT SCALE DRAWING
 SHEET SCALE: 1:2

DESCRIPTION: SFNX SI evaluation kit
 DWG. NO. REF-246550-X.XX-XX