

DO NOT SCALE FROM THIS PRINT

SMA-J-P-HG-ST-EM-01

**GENDER**  
-J: JACK

**TYPE**  
-P: PCB

**FINISH**  
-HG: 30µ" GOLD CENTER CONTACT,  
10µ" GOLD OUTER CONTACT

**OPTION**  
-01: PCB THICKNESS, 0.062"

**TERMINATION**  
-EM: EDGE MOUNT

**ORIENTATION**  
-ST: STRAIGHT

SMA JACK (F)  
INTERFACE I.A.W  
MIL-STD-348

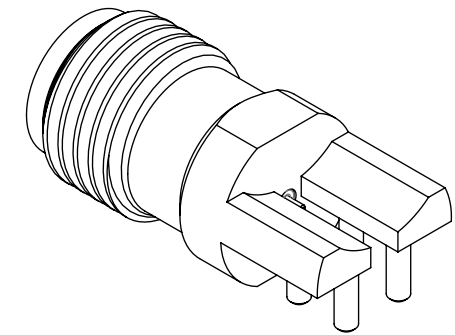
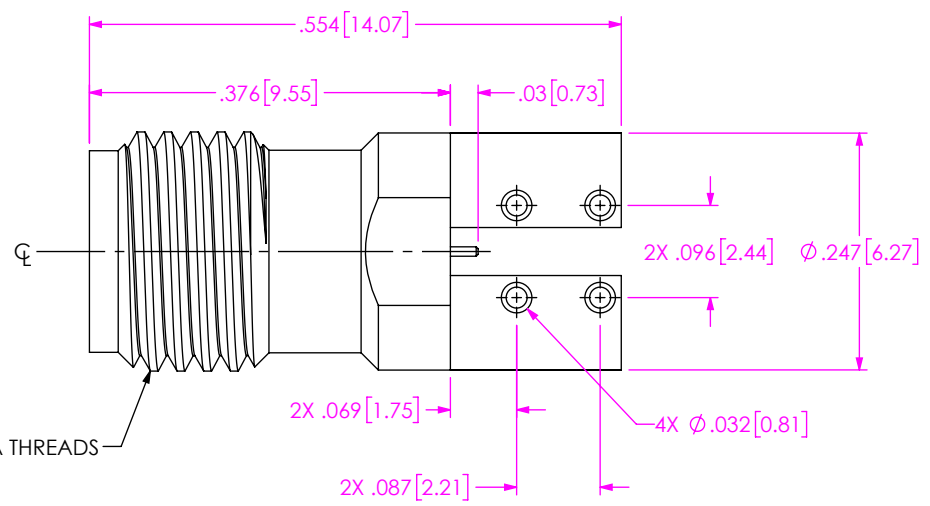
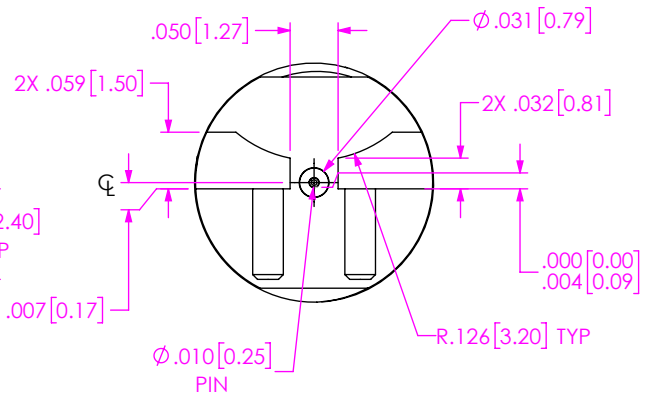
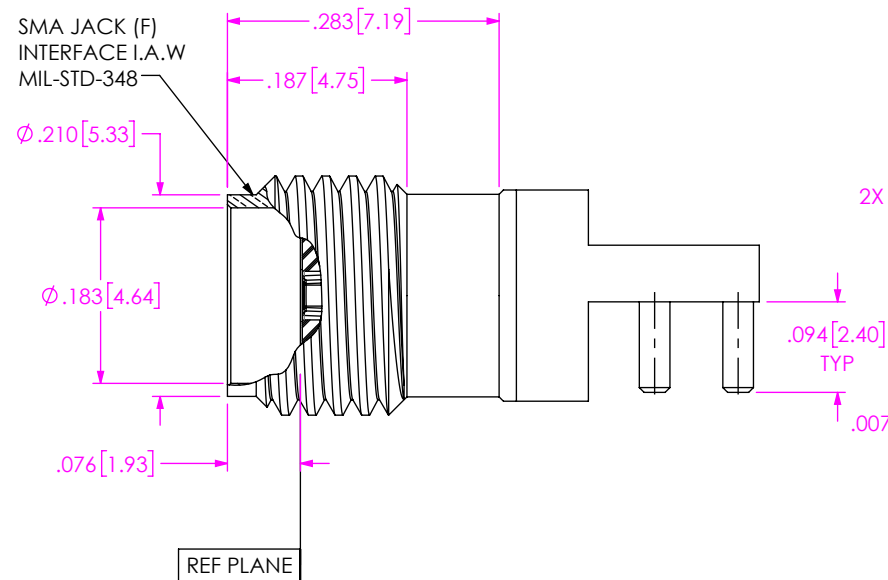

NOTES:

1. RECOMMENDED MATING TORQUE 3-5 INCH-POUNDS.
2. THIS IS A GENERAL FOOTPRINT AND IS NOT OPTIMIZED FOR ELECTRICAL PERFORMANCE, CONTACT SIG@SAMTEC.COM FOR ASSISTANCE WITH ELECTRICAL LAYOUT.

**PROPRIETARY NOTE**  
THIS DOCUMENT CONTAINS CONFIDENTIAL AND PROPRIETARY INFORMATION AND ALL DESIGN, MANUFACTURING, REPRODUCTION, USE, PATENT RIGHTS AND SALES RIGHTS ARE EXPRESSLY RESERVED BY SAMTEC, INC. THIS DOCUMENT SHALL NOT BE DISCLOSED, IN WHOLE OR PART, TO ANY UNAUTHORIZED PERSON OR ENTITY NOR REPRODUCED, TRANSFERRED OR INCORPORATED IN ANY OTHER PROJECT IN ANY MANNER WITHOUT THE EXPRESS WRITTEN CONSENT OF SAMTEC, INC.



520 PARK EAST BLVD., NEW ALBANY, IN 47150  
PHONE: 812-944-6733 FAX: 812-948-5047  
e-Mail: info@SAMTEC.com code: 55322

DO NOT SCALE DRAWING  
SHEET SCALE: 4:1

**MATERIAL:**  
BODY: GOLD PLATED BRASS ALLOY  
SOCKET CONTACT: GOLD PLATED BeCu  
COPPER ALLOY  
INSULATOR: PTFE

DESCRIPTION:  
SMA ST JACK EDGE MOUNT 4-POST

DWG. NO.  
SMA-J-P-HG-ST-EM-01

BY: ERIC O 8/18/2023 SHEET 1 OF 2

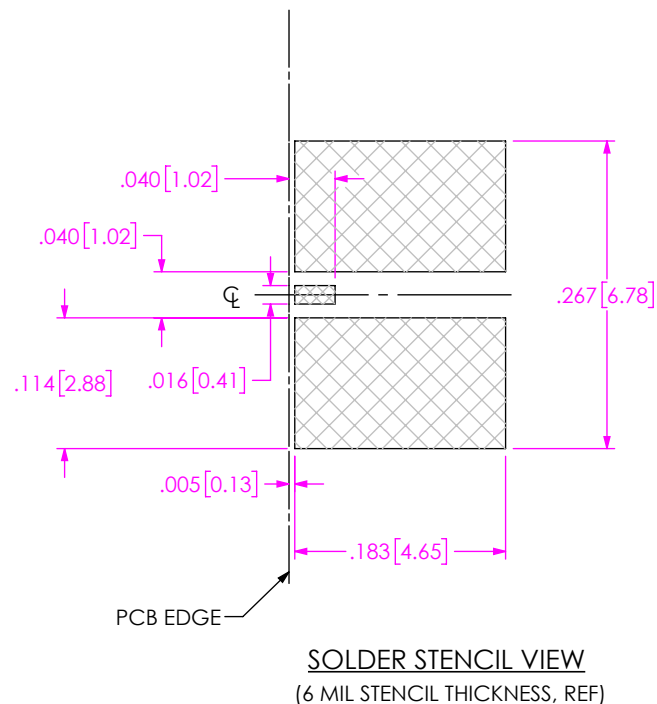
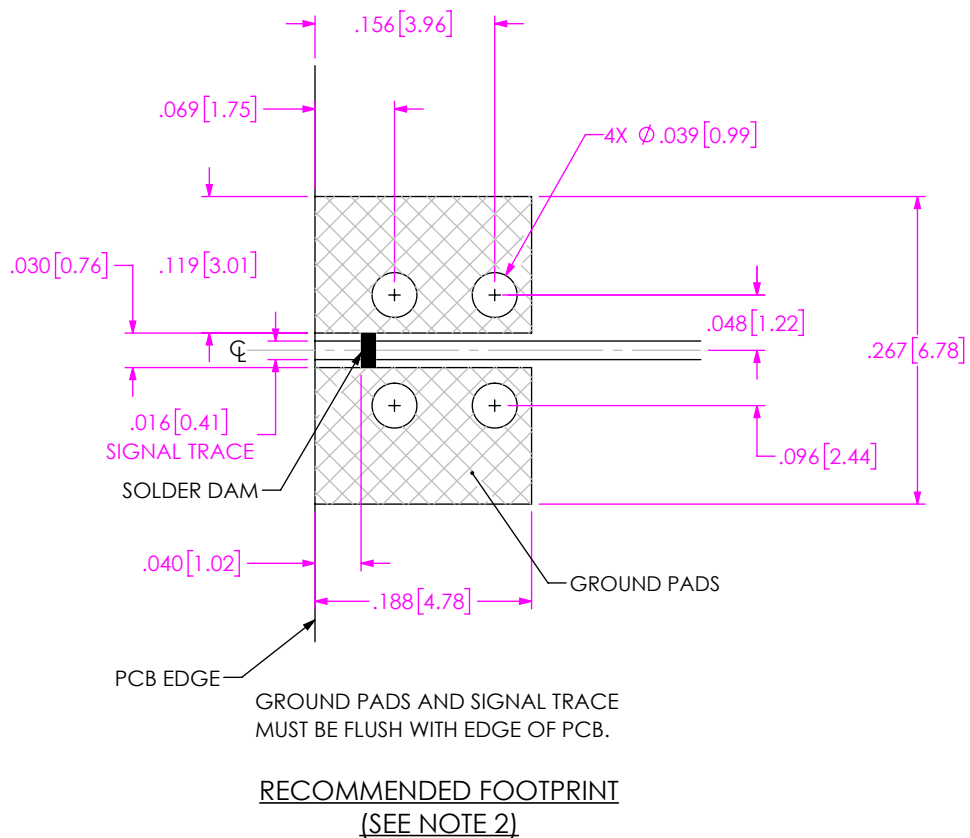

**PROPRIETARY NOTE**

THIS DOCUMENT CONTAINS CONFIDENTIAL AND PROPRIETARY INFORMATION AND ALL DESIGN, MANUFACTURING, REPRODUCTION, USE, PATENT RIGHTS AND SALES RIGHTS ARE EXPRESSLY RESERVED BY SAMTEC, INC. THIS DOCUMENT SHALL NOT BE DISCLOSED, IN WHOLE OR PART, TO ANY UNAUTHORIZED PERSON OR ENTITY NOR REPRODUCED, TRANSFERRED OR INCORPORATED IN ANY OTHER PROJECT IN ANY MANNER WITHOUT THE EXPRESS WRITTEN CONSENT OF SAMTEC, INC.

DO NOT SCALE DRAWING

SHEET SCALE: 8:1



520 PARK EAST BLVD, NEW ALBANY, IN 47150  
PHONE: 812-944-6733 FAX: 812-948-5047  
e-Mail: info@SAMTEC.com code: 55322

DESCRIPTION:

SMA ST JACK EDGE MOUNT 4-POST

DWG. NO.

SMA-J-P-HG-ST-EM-01

BY: ERIC O

8/18/2023

SHEET 2 OF 2