

DO NOT SCALE FROM THIS PRINT

THIS PRODUCT MANUFACTURED WITH LEAD-FREE PROCESSING

DESIGNED & DIMENSIONED IN MILLIMETERS [INCHES]

SMA-P-C-X-ST-CA5

GENDER
-P: PLUG

TYPE
-C: CABLE

TERMINATION
-CA5: CABLE
(.063" SEMI-FLEXIBLE CABLE)

ORIENTATION
-ST: STRAIGHT

PLATING SPECIFICATION
-H: 30μ" GOLD CENTER CONTACT,
3μ" GOLD OUTER CONTACT
(SEE TABLE 1)

| TABLE 1 | | |
|---------|--------------|----------------------|
| ITEM | COMPONENT | -H |
| 1 | SUB ASSEMBLY | SUB-SMA-P-C-F-ST-CA5 |
| 2 | PIN | SMA-PIN-007-H |
| 3 | INSULATOR | SMA-INS-011 |

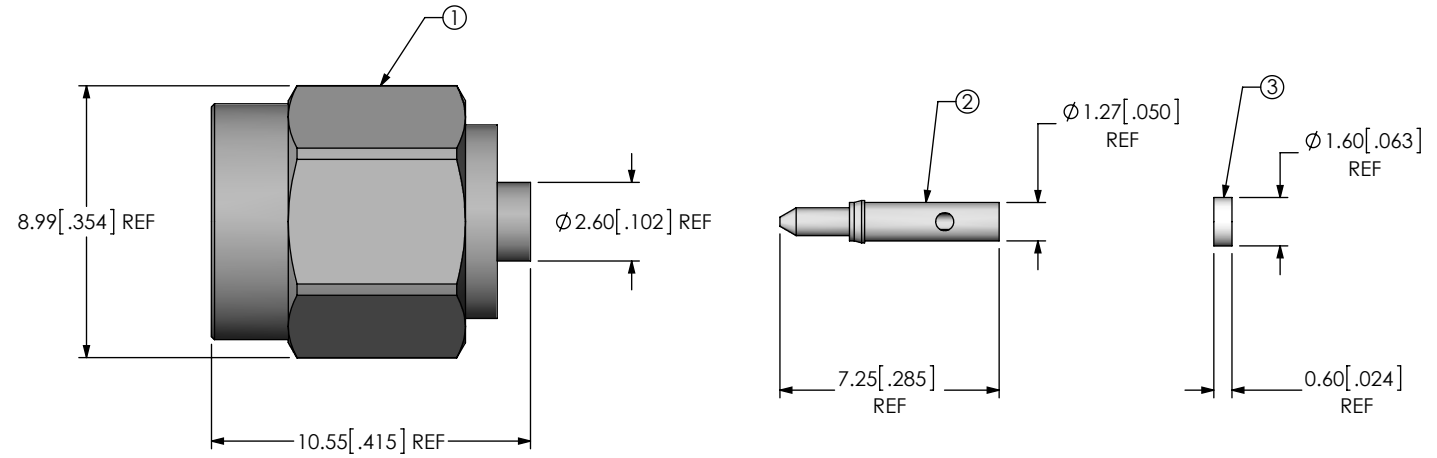

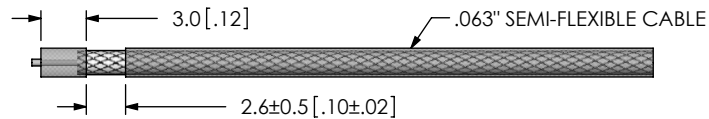

FIG 1
SMA-P-C-X-ST-CA5 SHOWN

- NOTES:
- Ⓢ REPRESENTS A CRITICAL DIMENSION.
 - CENTER CONTACT PUSHOUT FORCE: 13.35 N [3 LB] MIN.
 - SEE SHEET 3 FOR TERMINATION INFORMATION.
 - NOTE DELETED.
 - PRODUCT TO BE PACKAGED PER PACKAGING STANDARD CO-RF-WI-3040-M.
 - NOTE DELETED.
 - NOTE DELETED.
 - NOTE DELETED.

F:\DWG\MISC\MKTG\SMA-P-C-X-ST-CA5-MKT.SLDDRW

| | | |
|--|---|--|
| UNLESS OTHERWISE SPECIFIED, DIMENSIONS ARE IN MILLIMETERS [INCHES]. TOLERANCES ARE: DECIMALS ANGLES .X: ±0.3 [.01] 5° .XX: ±0.13 [.005] .XXX: ±0.051 [.0020] | PROPRIETARY NOTE THIS DOCUMENT CONTAINS INFORMATION CONFIDENTIAL AND PROPRIETARY TO SAMTEC, INC. AND SHALL NOT BE REPRODUCED OR TRANSFERRED TO OTHER DOCUMENTS OR DISCLOSED TO OTHERS OR USED FOR ANY PURPOSE OTHER THAN THAT WHICH IT WAS OBTAINED WITHOUT THE EXPRESSED WRITTEN CONSENT OF SAMTEC, INC. |  520 PARK EAST BLVD., NEW ALBANY, IN 47150 PHONE: 812-944-6733 FAX: 812-948-5047 e-Mail info@SAMTEC.com code 55322 |
| | | |
| BY: R MUSSER 01/22/2008 | | SHEET 1 OF 2 |



IN-PROCESS 1
STRIP AND LOCATE JACKET



IN-PROCESS 2
TIN INNER AND OUTER CONDUCTOR
REMOVE CUT JACKET

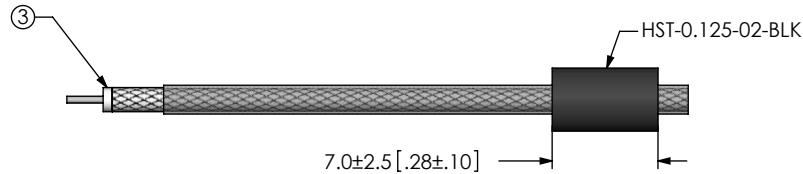

IN-PROCESS 3
ADD INSULATOR AND HEAT SHRINK TUBE



IN-PROCESS 4
SOLDER SIGNAL PIN

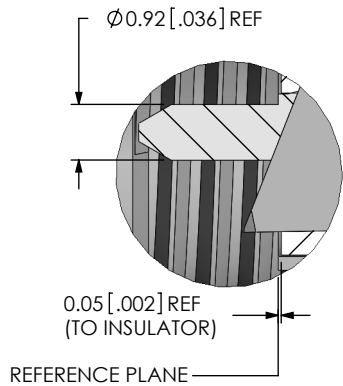

DETAIL 'A'
SCALE 8:1

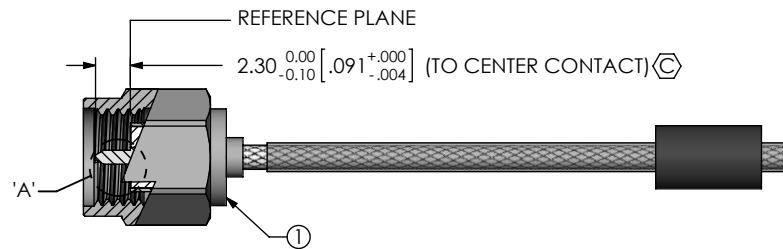

IN-PROCESS 5
ADD SUB ASSEMBLY

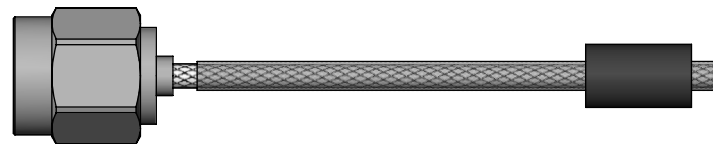

IN-PROCESS 6
SOLDER SUB ASSEMBLY

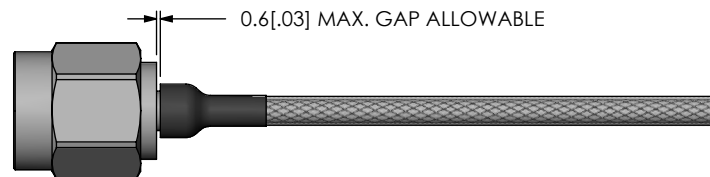

IN-PROCESS 7
APPLY HEAT SHRINK TUBING

F:\DWG\MISC\MKTG\SMA-P-C-X-ST-CA5-MKT.SLDDRW

PROPRIETARY NOTE

THIS DOCUMENT CONTAINS INFORMATION CONFIDENTIAL AND PROPRIETARY TO SAMTEC, INC. AND SHALL NOT BE REPRODUCED OR TRANSFERRED TO OTHER DOCUMENTS OR DISCLOSED TO OTHERS OR USED FOR ANY PURPOSE OTHER THAN THAT WHICH IT WAS OBTAINED WITHOUT THE EXPRESSED WRITTEN CONSENT OF SAMTEC, INC.

DO NOT SCALE DRAWING

SHEET SCALE: 2:1



520 PARK EAST BLVD, NEW ALBANY, IN 47150
PHONE: 812-944-6733 FAX: 812-948-5047
e-Mail: info@SAMTEC.com code 55322

DESCRIPTION:
SMA STRAIGHT CABLE PLUG, 25 AWG CABLE - 50 OHM

DWG. NO.
SMA-P-C-X-ST-CA5

BY: R MUSSER 01/22/2008 SHEET 2 OF 2