

**THIS PRODUCT MANUFACTURED WITH LEAD-FREE PROCESSING**

**DESIGNED & DIMENSIONED IN MILLIMETERS [INCHES]**

DO NOT SCALE FROM THIS PRINT

TABLE 1		
ITEM	COMPONENT	-H
1	SUB ASSEMBLY	SUB-SMA-P-C-F-ST-CS5
2	PIN	SMA-PIN-007-H
3	INSULATOR	SMA-INS-018

**SMA-P-C-X-ST-CS5**

GENDER  
-P: PLUG

TERMINATION  
-CS5: CABLE (MWC-2550-01)

TYPE  
-C: CABLE

ORIENTATION  
-ST: STRAIGHT

PLATING SPECIFICATION  
-H: 30μ" GOLD CENTER CONTACT, 3μ" GOLD OUTER CONTACT (SEE TABLE 1)

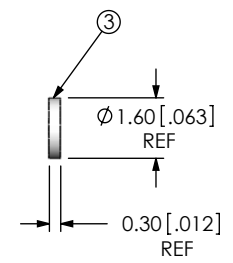
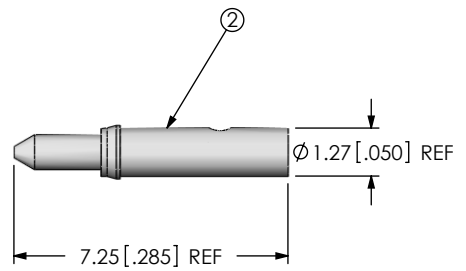
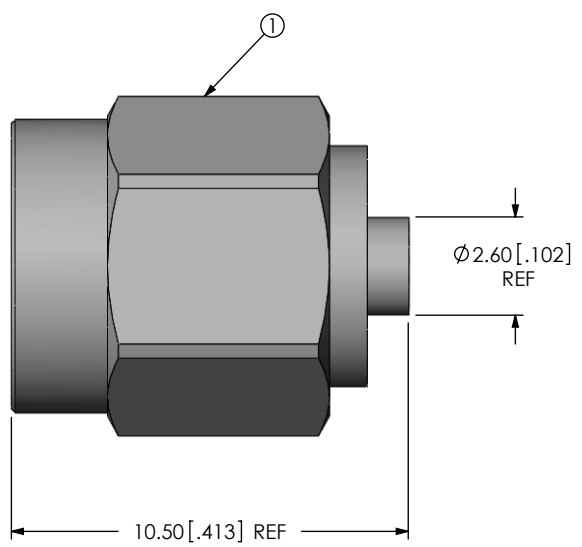

- NOTES:
- ① REPRESENTS A CRITICAL DIMENSION.
  - CENTER CONTACT PUSHOUT FORCE: 26.69 N [6 LB] MIN.
  - NOTE DELETED.
  - PRODUCT TO BE PACKAGED PER PACKAGING STANDARD CO-RF-WI-3040-M.
  - NOTE DELETED.
  - NOTE DELETED.
  - NOTE DELETED.

UNLESS OTHERWISE SPECIFIED, DIMENSIONS ARE IN MILLIMETERS [INCHES]. TOLERANCES ARE: DECIMALS ANGLES .X: ±0.3 [0.1] 5° .XX: ±0.13 [0.05] .XXX: ±0.051 [0.020]	<b>PROPRIETARY NOTE</b> THIS DOCUMENT CONTAINS INFORMATION CONFIDENTIAL AND PROPRIETARY TO SAMTEC, INC. AND SHALL NOT BE REPRODUCED OR TRANSFERRED TO OTHER DOCUMENTS OR DISCLOSED TO OTHERS OR USED FOR ANY PURPOSE OTHER THAN THAT WHICH IT WAS OBTAINED WITHOUT THE EXPRESSED WRITTEN CONSENT OF SAMTEC, INC.	 520 PARK EAST BLVD., NEW ALBANY, IN 47150 PHONE: 812-944-6733 FAX: 812-948-5047 e-Mail info@SAMTEC.com code 55322
BY: J. BROWNING 06/14/2010		SHEET 1 OF 2

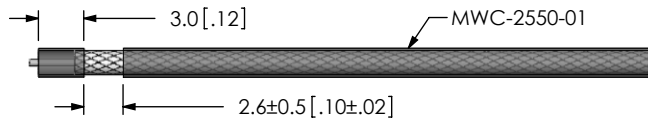

IN-PROCESS 1  
STRIP AND LOCATE JACKET



IN-PROCESS 2  
TIN INNER AND OUTER CONDUCTOR  
REMOVE CUT JACKET

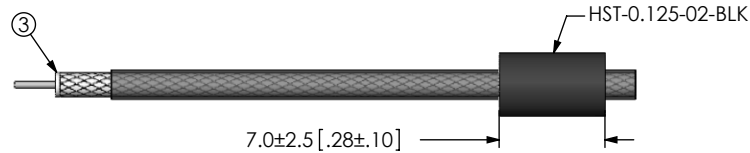

IN-PROCESS 3  
ADD INSULATOR AND HEAT SHRINK TUBE



IN-PROCESS 4  
SOLDER SIGNAL PIN

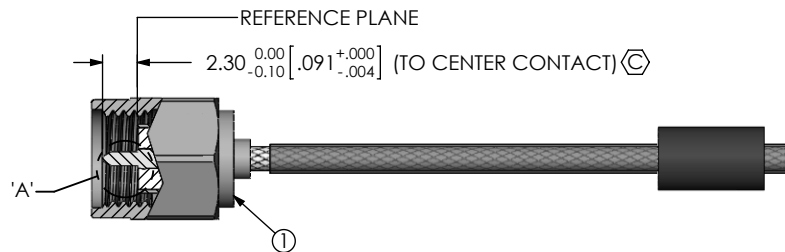

IN-PROCESS 5  
ADD SUB ASSEMBLY



IN-PROCESS 6  
SOLDER SUB ASSEMBLY

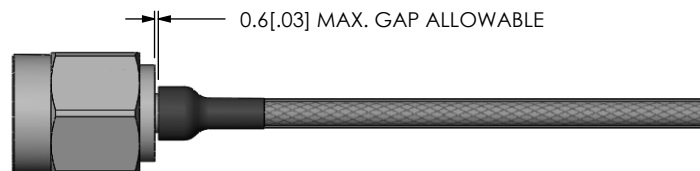

IN-PROCESS 7  
APPLY HEAT SHRINK TUBING

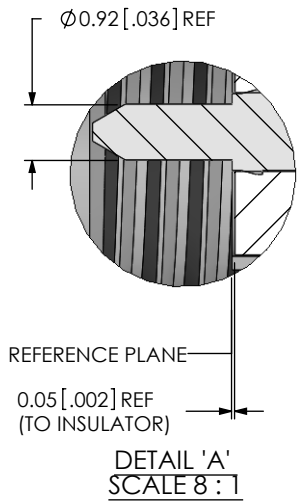

C:\EnterpriseVault\DWG\MISC\MKTG\SMA-P-C-X-ST-CS5-MKT.SLDDRW

**PROPRIETARY NOTE**  
THIS DOCUMENT CONTAINS INFORMATION  
CONFIDENTIAL AND PROPRIETARY TO  
SAMTEC, INC. AND SHALL NOT BE REPRODUCED  
OR TRANSFERRED TO OTHER DOCUMENTS OR  
DISCLOSED TO OTHERS OR USED FOR ANY  
PURPOSE OTHER THAN THAT WHICH IT WAS  
OBTAINED WITHOUT THE EXPRESSED WRITTEN  
CONSENT OF SAMTEC, INC.

DO NOT SCALE DRAWING

SHEET SCALE: 2:1



520 PARK EAST BLVD, NEW ALBANY, IN 47150  
PHONE: 812-944-6733 FAX: 812-948-5047  
e-Mail: info@SAMTEC.com code 55322

DESCRIPTION:  
SMA STRAIGHT CABLE PLUG, 25 AWG CABLE - 50 OHM

DWG. NO.  
**SMA-P-C-X-ST-CS5**

BY: J. BROWNING 06/14/2010 SHEET 2 OF 2