

**THIS PRODUCT MANUFACTURED WITH LEAD-FREE PROCESSING**

**DESIGNED & DIMENSIONED IN MILLIMETERS [INCHES]**

DO NOT SCALE FROM THIS PRINT

**SMP-J-C-XX-RA-CA7-X**

**GENDER**  
-J: JACK

**TYPE**  
-C: CABLE

**PACKAGING**  
-BLANK: INDIVIDUALLY BAGGED  
-B: BULK PACKAGED (QTY=100 MAX)

**TERMINATION**  
-CA7: CCA-405 CABLE

**ORIENTATION (RG405 SEMI FLEXIBLE CABLE)**  
-RA: RIGHT ANGLE

**PLATING SPECIFICATION**  
-HG: HEAVY GOLD / GOLD  
30µ" Au / 50µ" Ni MIN ON PIN  
10µ" Au / 50µ" Ni MIN ON OUTER CONTACT  
3µ" Au / 50µ" Ni MIN ON CAP  
-GF: GOLD / FLASH GOLD  
10µ" Au / 50µ" Ni MIN ON PIN  
3µ" Au / 50µ" Ni MIN ON OUTER CONTACT  
100µ" Ni MIN ON CAP  
(SEE TABLE 1)

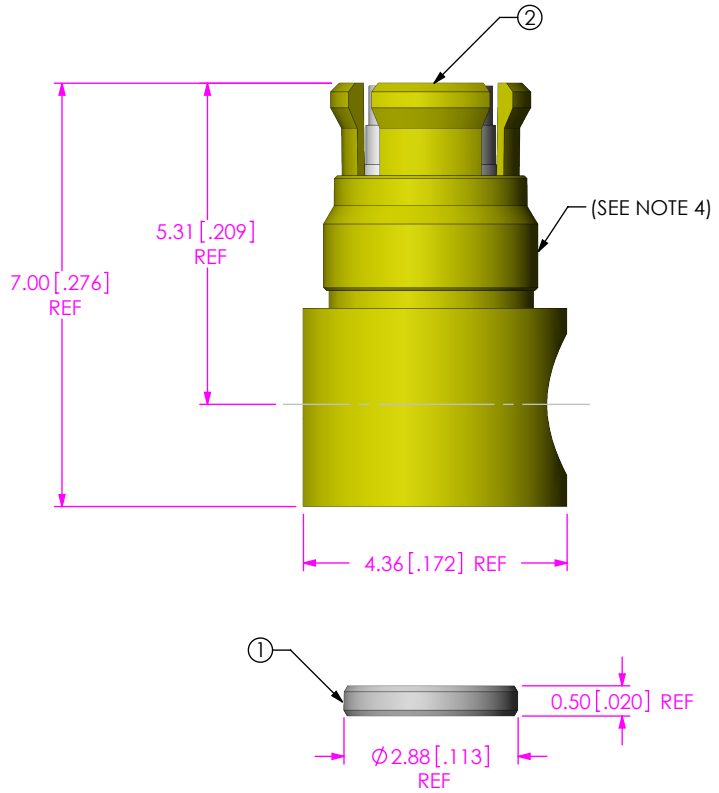

ITEM	COMPONENT	-HG	-GF
1	CAP	MMCX-CAP-001-F	MMCX-CAP-001-N
2	SUB ASSEMBLY	SUB-SMP-J-C-HG-RA-CA7	SUB-SMP-J-C-GF-RA-CA7

**UNLESS OTHERWISE SPECIFIED, DIMENSIONS ARE IN MILLIMETERS.**

**TOLERANCES ARE:**

DECIMALS	ANGLES
X.X: ±0.3 [.01]	5°
X.XX: ±0.13 [.005]	
X.XXX: ±0.051 [.0020]	

**PROPRIETARY NOTE**  
THIS DOCUMENT CONTAINS INFORMATION CONFIDENTIAL AND PROPRIETARY TO SAMTEC, INC. AND SHALL NOT BE REPRODUCED OR TRANSFERRED TO OTHER DOCUMENTS OR DISCLOSED TO OTHERS OR USED FOR ANY PURPOSE OTHER THAN THAT WHICH IT WAS OBTAINED WITHOUT THE EXPRESSED WRITTEN CONSENT OF SAMTEC, INC.

**samtec**

520 PARK EAST BLVD, NEW ALBANY, IN 47150  
PHONE: 812-944-6733 FAX: 812-948-5047  
e-Mail: info@SAMTEC.com code 55322

- NOTES:
- ① REPRESENTS A CRITICAL DIMENSION.
  - PRODUCT TO BE PACKAGED PER PRECISION RF SECTION OF PACKAGING MANUAL.  
TRAY: TY-SMA001-1  
COVER: TY-SMA001-2  
200 PARTS PER TRAY (2 PARTS PER POCKET)
  - CAP TO BE PACKAGED SEPARATELY.
  - THE RING IS LOOSE AND CAN MOVE, 1.5 LBS MIN FORCE TO REMOVE.

MATERIAL: DO NOT SCALE DRAWING SHEET SCALE: 8:1

SUB ASSEMBLY:  
INSULATOR: PTFE  
BODY, RING & SOCKET: BeCu  
CAP: BRASS

DESCRIPTION:  
SMP RA JACK FOR CCA-405 - 50 OHM

DWG. NO.  
**SMP-J-C-XX-RA-CA7-X**



IN-PROCESS 1  
STRIP AND TIN INNER CONDUCTOR

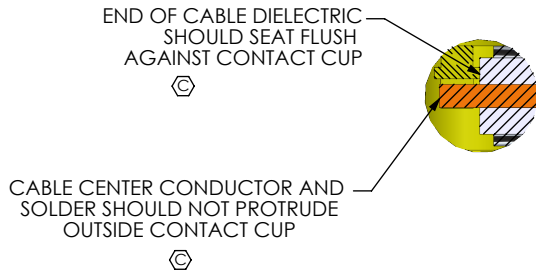

DETAIL 'A'  
SCALE 6 : 1



IN-PROCESS 2  
ADD SUB ASSEMBLY & SOLDER BRAID



IN-PROCESS 3  
SOLDER SIGNAL CONTACT

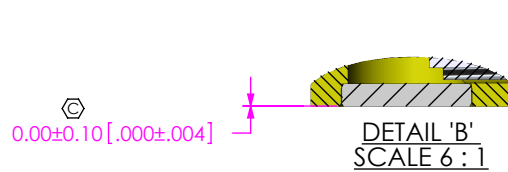

IN-PROCESS 4  
INSERT CAP

**PROPRIETARY NOTE**  
THIS DOCUMENT CONTAINS INFORMATION CONFIDENTIAL AND PROPRIETARY TO SAMTEC, INC. AND SHALL NOT BE REPRODUCED OR TRANSFERRED TO OTHER DOCUMENTS OR DISCLOSED TO OTHERS OR USED FOR ANY PURPOSE OTHER THAN THAT WHICH IT WAS OBTAINED WITHOUT THE EXPRESSED WRITTEN CONSENT OF SAMTEC, INC.

DO NOT SCALE DRAWING

SHEET SCALE: 8:1

**samtec**

520 PARK EAST BLVD, NEW ALBANY, IN 47150  
PHONE: 812-944-6733 FAX: 812-948-5047  
e-Mail info@SAMTEC.com code 55322

DESCRIPTION:  
SMP RA JACK FOR CCA-405 - 50 OHM

DWG. NO.  
SMP-J-C-XX-RA-CA7-X

BY: J. BROWNING 02/08/2011 SHEET 2 OF 3

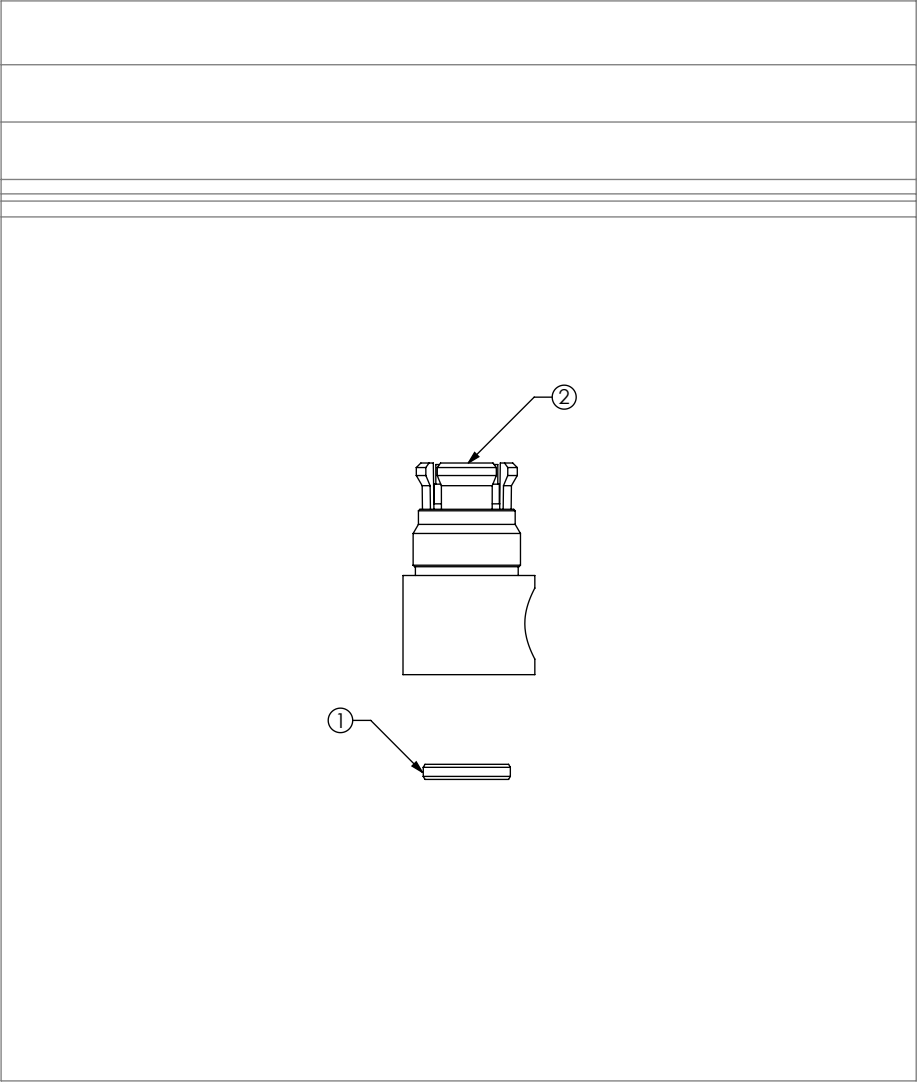

PACKAGING VIEW  
SMP-J-C-XX-RA-CA7 SHOWN

<p><b>PROPRIETARY NOTE</b> THIS DOCUMENT CONTAINS INFORMATION CONFIDENTIAL AND PROPRIETARY TO SAMTEC, INC. AND SHALL NOT BE REPRODUCED OR TRANSFERRED TO OTHER DOCUMENTS OR DISCLOSED TO OTHERS OR USED FOR ANY PURPOSE OTHER THAN THAT WHICH IT WAS OBTAINED WITHOUT THE EXPRESSED WRITTEN CONSENT OF SAMTEC, INC.</p> <p>DO NOT SCALE DRAWING</p> <p>SHEET SCALE: 8:1</p>	 <p>520 PARK EAST BLVD, NEW ALBANY, IN 47150 PHONE: 812-944-6733 FAX: 812-948-5047 e-Mail info@SAMTEC.com code 55322</p>
	<p>DESCRIPTION: SMP RA JACK FOR CCA-405 - 50 OHM</p>
	<p>DWG. NO. <b>SMP-J-C-XX-RA-CA7-X</b></p>
	<p>BY: J. BROWNING 02/08/2011 SHEET 3 OF 3</p>