

TABLE 1			
No. OF POS	"A"	"B"	"C"
-10	4.25 [0.167]	3.600 [0.1417]	5.40 [0.213]
*-15	6.25 [0.246]	5.600 [0.2205]	7.40 [0.291]
-20	8.25 [0.325]	7.600 [0.2992]	9.40 [0.370]
-30	12.25 [0.482]	11.600 [0.4567]	13.40 [0.528]
-40	16.25 [0.640]	15.600 [0.6142]	17.40 [0.685]
-50	20.25 [0.797]	19.600 [0.7717]	21.40 [0.843]

\* = NOT TOOLED FOR LEAD STYLE 2.50

DO NOT SCALE FROM THIS PRINT

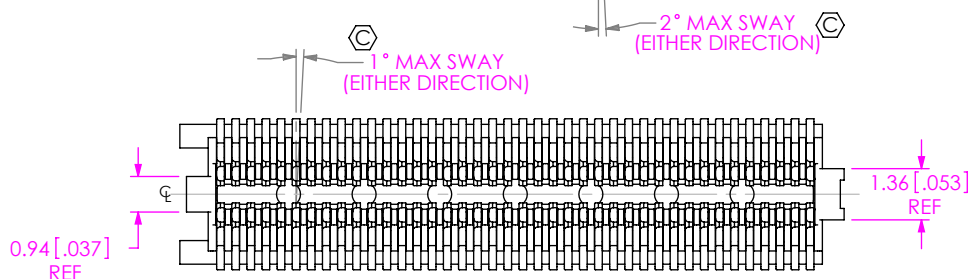
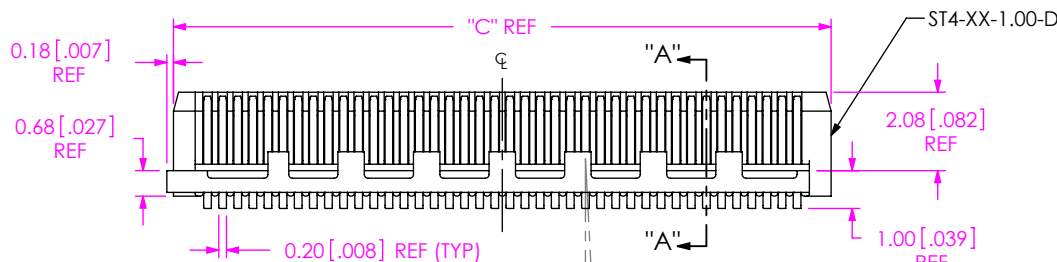
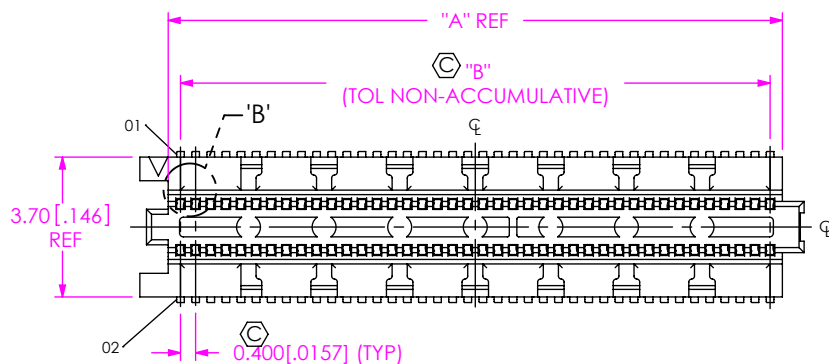


FIG 1  
ST4-40-1.00-X-D SHOWN

DESIGNED & DIMENSIONED IN MILLIMETERS (INCHES)

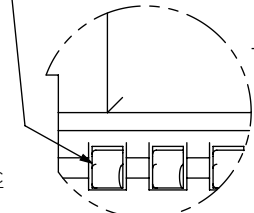
ST4-XX-X.XX-X-D-X-XX-XR

No OF POSITIONS  
-10, \*-15, -20, -30, -40, -50 (PER ROW)

LEAD STYLE  
-1.00: SEE FIG 1 (USE T-1M50-1.00-X)  
-1.50: SEE FIG 2, SHT 2 (USE T-1M50-1.50-X)  
-2.50: SEE FIG 3, SHT 2 (USE T-1M50-2.50-X)

PLATING SPECIFICATION  
-L: 10µ" SELECTIVE GOLD IN CONTACT AREA, MATTE TIN ON TAIL (USE T-1M50-X.XX-L)

DIE ROLL TO FACE POSITION 1 END



DETAIL 'B'  
SCALE 20:1

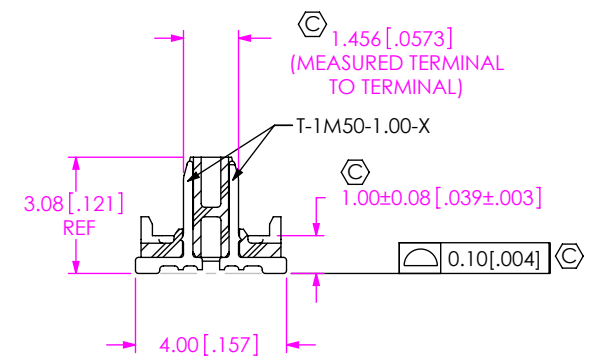
\* = NOT TOOLED FOR LEAD STYLE 2.50  
\*\* = AVAILABLE FOR EXISTING CUSTOMERS ONLY

PACKAGING (SEE NOTES 3, 6 & 7)  
-TR: TAPE AND REEL  
-FR: FULL REEL QTY TAPE & REEL

PLACEMENT PAD  
-P: PICK AND PLACE PAD (-10, -20, -30, -40, -50 USE PPP-65-01, -15 USE PPP-65-02) (SEE FIG 7 & 8, SHT 3)  
\*\*-PA: PICK AND PLACE PAD WITH -A PINS (USE PPP-70) (SEE FIG 9 & 10, SHT 4) (NOT AVAILABLE ON -15 POS)

OPTIONS  
\*\*-L: LATCHING (USE WT-39-X.XX-T) (LEAVE BLANK FOR NO OPTION) (TOOLED FOR LEAD STYLE 1.00 ONLY)

ROW SPECIFICATION  
-D: DOUBLE



SECTION "A"- "A"

TABLE 2 REF		
STACK HEIGHT		
ST4 LEAD STYLE	SS4 LEAD STYLE	
	-3.00	-3.50
-1.00	4.0 [0.16]	4.5 [0.18]
-1.50	4.5 [0.18]	5.0 [0.20]
-2.50	5.5 [0.22]	6.0 [0.24]

- NOTES:
- ⊗ REPRESENTS A CRITICAL DIMENSION.
  - MINIMUM PUSHOUT FORCE: SIGNAL: 0.80N [25 LB], LATCH: 2.22N [5 LB]
  - P OPTION MUST BE SPECIFIED FOR TAPE & REEL PACKAGING.
  - NOTE DELETED.
  - L OPTION NOT INTENDED FOR FOR ALIGNMENT TO PCB. AUTOMATED PLACEMENT RECOMMENDED.
  - ORDERS WILL BE PACKAGED ACCORDING TO THE SAMTEC PACKAGING EFFICIENCY STANDARDS (SPES) FOUND ON WWW.SAMTEC.COM
  - ATTACH LABEL TO EACH REEL

UNLESS OTHERWISE SPECIFIED, DIMENSIONS ARE IN MILLIMETERS.  
TOLERANCES ARE:  
DECIMALS ANGLES  
.X: ±0.3 [0.1] 2°  
.XX: ±0.13 [0.05]  
.XXX: ±0.051 [0.020]

PROPRIETARY NOTE  
THIS DOCUMENT CONTAINS CONFIDENTIAL AND PROPRIETARY INFORMATION AND ALL DESIGN, MANUFACTURING, REPRODUCTION, USE, PATENT RIGHTS AND SALES RIGHTS ARE EXPRESSLY RESERVED BY SAMTEC, INC. THIS DOCUMENT SHALL NOT BE DISCLOSED, IN WHOLE OR PART, TO ANY UNAUTHORIZED PERSON OR ENTITY NOR REPRODUCED, TRANSFERRED OR INCORPORATED IN ANY OTHER PROJECT IN ANY MANNER WITHOUT THE EXPRESS WRITTEN CONSENT OF SAMTEC, INC.

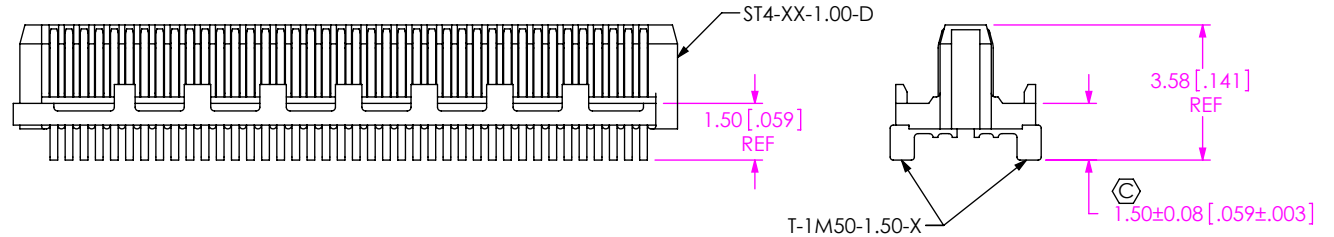
MATERIAL: DO NOT SCALE DRAWING SHEET SCALE: 5:1  
INSULATOR: LCP, UL 94 V0, COLOR: BLACK  
TERMINAL: PHOS BRONZE



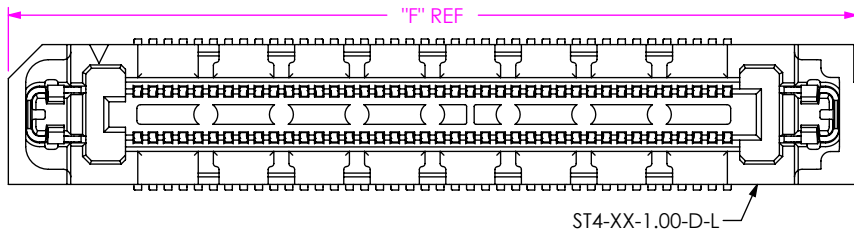
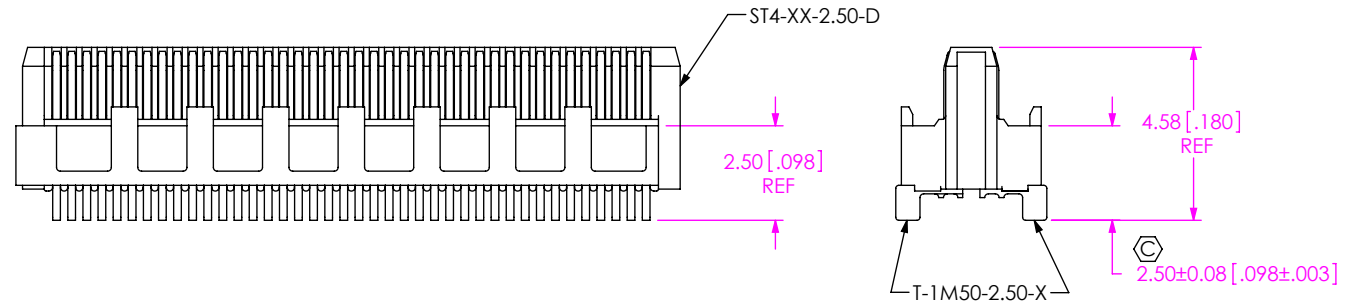
520 PARK EAST BLVD, NEW ALBANY, IN 47150  
PHONE: 812-944-6733 FAX: 812-948-5047  
e-Mail info@SAMTEC.com code 55322

DESCRIPTION:  
0.4mm [0.016] TERMINAL STRIP ASSEMBLY  
DWG. NO.  
ST4-XX-X.XX-X-D-X-XX-XR  
BY: BRATCHER 3/21/2007 SHEET 1 OF 4

**FIG 2**  
1.50 LEAD STYLE  
ST4-40-1.50-X-D SHOWN  
(DIFFERENT AS SHOWN, OTHERWISE SAME AS FIG 1)

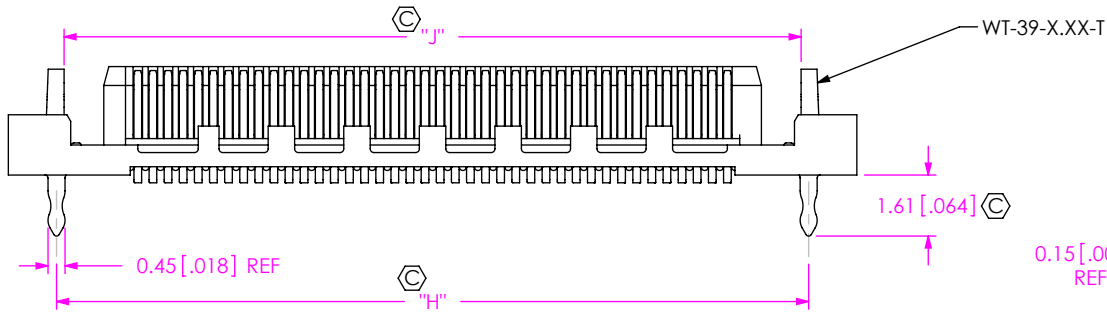
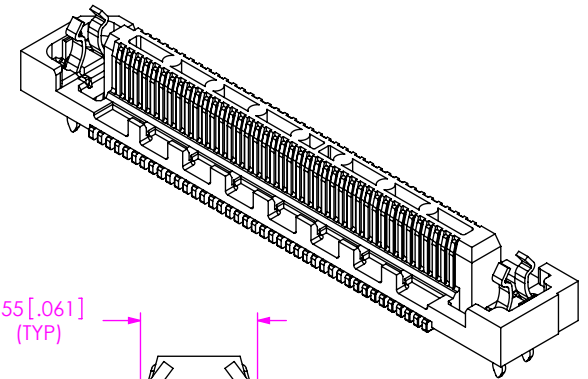


**FIG 3**  
2.50 LEAD STYLE  
ST4-40-2.50-X-D SHOWN  
(DIFFERENT AS SHOWN, OTHERWISE SAME AS FIG 1)



LEAD STYLE	LATCH
-1.00	WT-39-1.00-T
-1.50	WT-39-1.50-T
-2.50	WT-39-2.50-T

TOOLED FOR -1.00 LEAD STYLE ONLY



No. OF POS	"F"	"H"	"J"
-10	10.46 [0.412]	7.90 [0.311]	7.50 [0.295]
-15	12.46 [0.491]	9.90 [0.390]	9.50 [0.374]
-20	14.46 [0.569]	11.90 [0.469]	11.50 [0.453]
-30	18.46 [0.727]	15.90 [0.626]	15.50 [0.610]
-40	22.46 [0.884]	19.90 [0.783]	19.50 [0.768]
-50	26.46 [1.042]	23.90 [0.941]	23.50 [0.925]

**FIG 5**  
\*\*-L: LATCHING OPTION  
ST4-40-1.00-X-D-L SHOWN  
(DIFFERENT AS SHOWN, OTHERWISE SAME AS FIG 1)  
\*\* = AVAILABLE FOR EXISTING CUSTOMERS ONLY

**PROPRIETARY NOTE**  
THIS DOCUMENT CONTAINS CONFIDENTIAL AND PROPRIETARY INFORMATION AND ALL DESIGN, MANUFACTURING, REPRODUCTION, USE, PATENT RIGHTS AND SALES RIGHTS ARE EXPRESSLY RESERVED BY SAMTEC, INC. THIS DOCUMENT SHALL NOT BE DISCLOSED, IN WHOLE OR PART, TO ANY UNAUTHORIZED PERSON OR ENTITY NOR REPRODUCED, TRANSFERRED OR INCORPORATED IN ANY OTHER PROJECT IN ANY MANNER WITHOUT THE EXPRESS WRITTEN CONSENT OF SAMTEC, INC.

DO NOT SCALE DRAWING

SHEET SCALE: 5:1

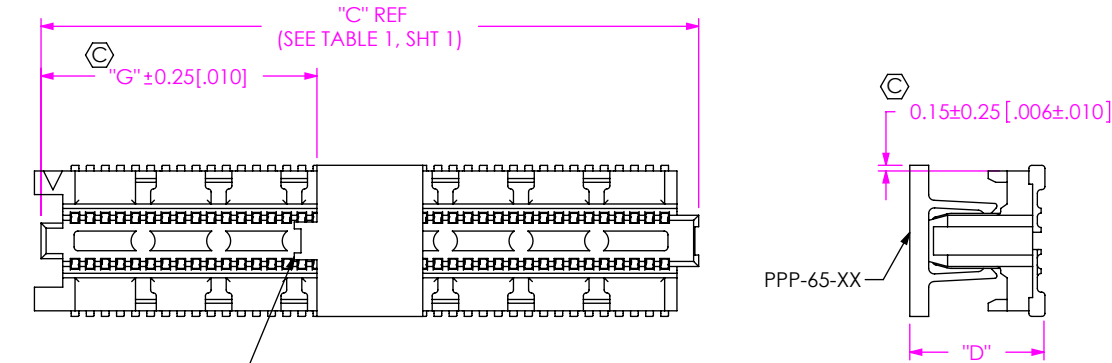


520 PARK EAST BLVD, NEW ALBANY, IN 47150  
PHONE: 812-944-6733 FAX: 812-948-5047  
e-Mail info@SAMTEC.com code 55322

DESCRIPTION:  
0.4mm[.016] TERMINAL STRIP ASSEMBLY

DWG. NO.  
**ST4-XX-X.XX-X-D-X-XX-XR**

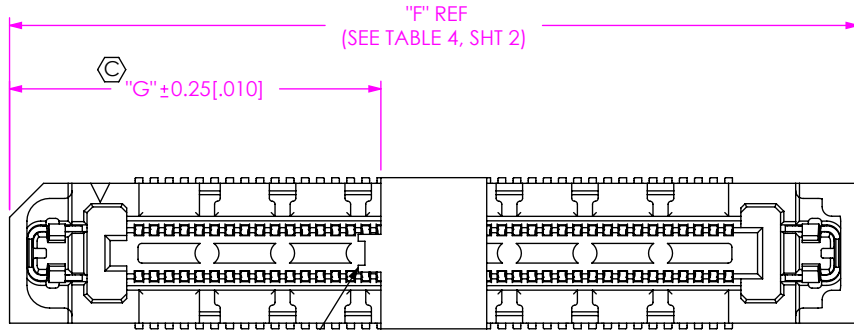
BY: BRATCHER 3/21/2007 SHEET 2 OF 4



NOTCH OF PPP-65-XX TO FACE POS 1 END

**FIG 7**  
 -P: PICK AND PLACE PAD OPTION  
 ST4-40-1.00-X-D-P SHOWN  
 (DIFFERENT AS SHOWN, OTHERWISE SAME AS FIG 1)

LEAD STYLE	"D"
-1.00	3.55 [0.140]
-1.50	4.05 [0.159]
-2.50	5.05 [0.199]



NOTCH OF PPP-65-XX TO FACE POS 1 END

**FIG 8**  
 -P: PICK AND PLACE PAD (W/ LATCH OPTION)  
 ST4-40-1.00-X-D-L-P SHOWN  
 (DIFFERENT AS SHOWN, OTHERWISE SAME AS FIG 1)

No. OF POS	"G" WITH NO -L OPTION	"G" WITH -L OPTION
-10	1.30 [0.051]	3.83 [0.151]
*-15	2.30 [0.091]	4.83 [0.190]
-20	3.30 [0.130]	5.83 [0.230]
-30	5.30 [0.209]	7.83 [0.308]
-40	7.30 [0.287]	9.83 [0.387]
-50	9.30 [0.366]	11.83 [0.466]

\* = NOT TOOLED FOR LEAD STYLE 2.50

**PROPRIETARY NOTE**  
 THIS DOCUMENT CONTAINS CONFIDENTIAL AND PROPRIETARY INFORMATION AND ALL DESIGN, MANUFACTURING, REPRODUCTION, USE, PATENT RIGHTS AND SALES RIGHTS ARE EXPRESSLY RESERVED BY SAMTEC, INC. THIS DOCUMENT SHALL NOT BE DISCLOSED, IN WHOLE OR PART, TO ANY UNAUTHORIZED PERSON OR ENTITY NOR REPRODUCED, TRANSFERRED OR INCORPORATED IN ANY OTHER PROJECT IN ANY MANNER WITHOUT THE EXPRESS WRITTEN CONSENT OF SAMTEC, INC.

DO NOT SCALE DRAWING

SHEET SCALE: 5:1

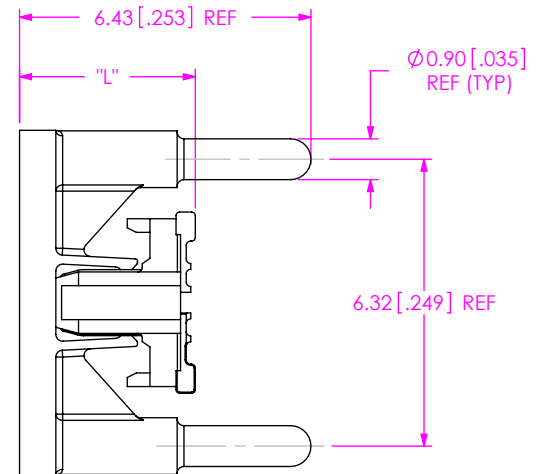
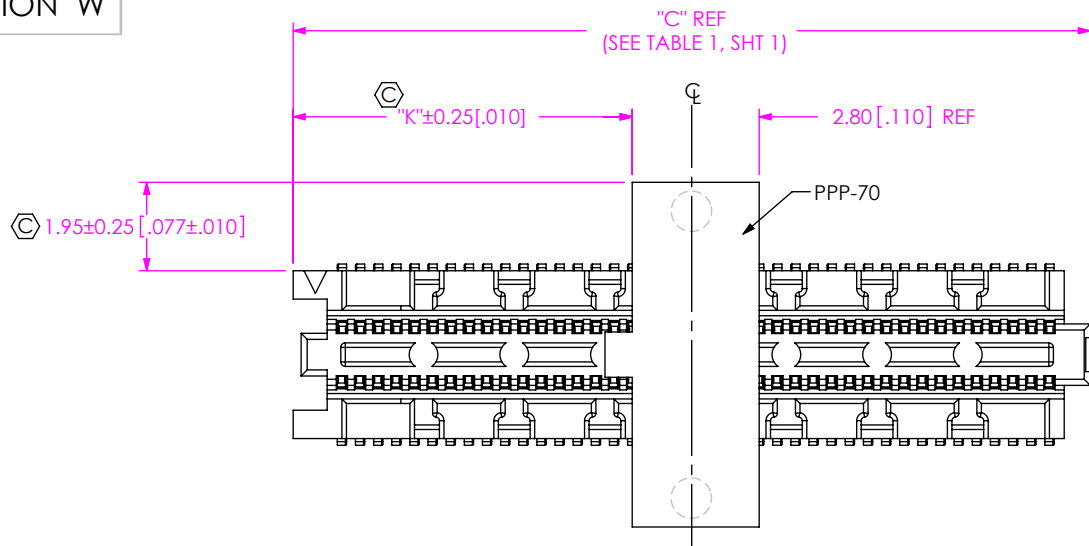


520 PARK EAST BLVD, NEW ALBANY, IN 47150  
 PHONE: 812-944-6733 FAX: 812-948-5047  
 e-Mail info@SAMTEC.com code 55322

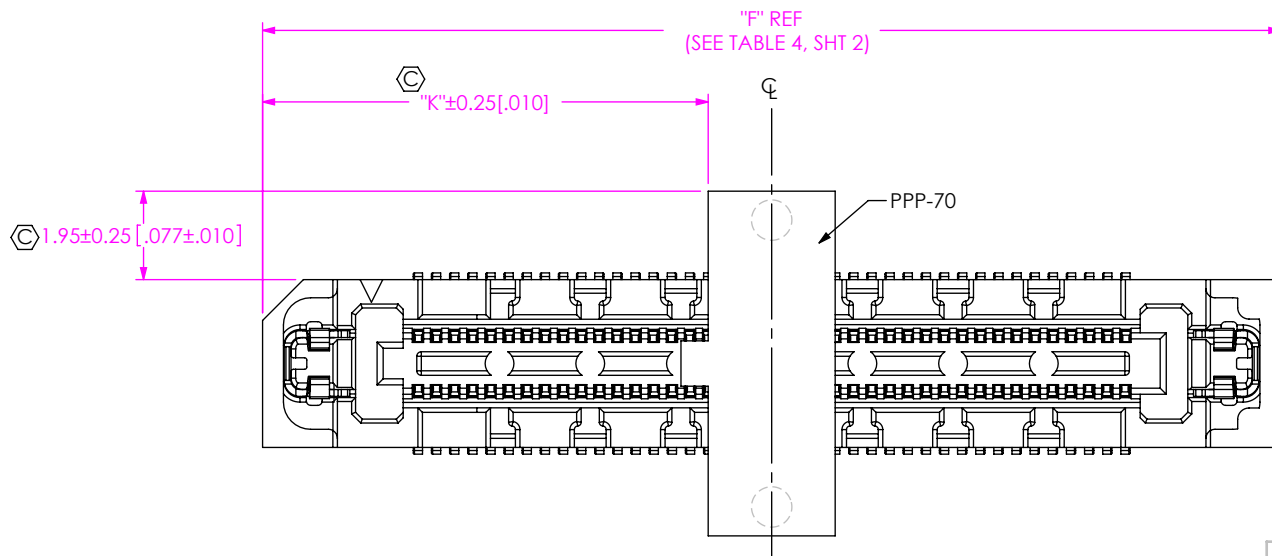
DESCRIPTION:  
 0.4mm[.016] TERMINAL STRIP ASSEMBLY

DWG. NO.  
**ST4-XX-X.XX-X-D-X-XX-XR**

BY: BRATCHER 3/21/2007 SHEET 3 OF 4



**FIG 9**  
 \*\*-PA: PICK & PLACE WITH ALIGNMENT PINS  
 ST4-40-1.00-X-D-PA SHOWN  
 (DIFFERENT AS SHOWN, OTHERWISE SAME AS FIG 1)  
 \*\* = AVAILABLE FOR EXISTING CUSTOMERS ONLY



**FIG 10**  
 \*\*-PA: PICK & PLACE WITH ALIGNMENT PINS ( WITH -L OPTION)  
 ST4-40-1.00-X-D-L-PA SHOWN  
 (DIFFERENT AS SHOWN, OTHERWISE SAME AS FIG 1)  
 \*\* = AVAILABLE FOR EXISTING CUSTOMERS ONLY

POS	"K" W/O -L OPTION	"K" W/ -L OPTION
-10	1.300 [0.051]	3.830 [0.151]
-20	3.300 [0.130]	5.830 [0.230]
-30	5.300 [0.209]	7.830 [0.308]
-40	7.300 [0.287]	9.830 [0.387]
-50	9.300 [0.366]	11.830 [0.466]

LEAD STYLE	"L"
-1.00	3.58 [0.141]
-1.50	4.08 [0.161]
-2.50	5.08 [0.200]

**PROPRIETARY NOTE**  
 THIS DOCUMENT CONTAINS CONFIDENTIAL AND PROPRIETARY INFORMATION AND ALL DESIGN, MANUFACTURING, REPRODUCTION, USE, PATENT RIGHTS AND SALES RIGHTS ARE EXPRESSLY RESERVED BY SAMTEC, INC. THIS DOCUMENT SHALL NOT BE DISCLOSED, IN WHOLE OR PART, TO ANY UNAUTHORIZED PERSON OR ENTITY NOR REPRODUCED, TRANSFERRED OR INCORPORATED IN ANY OTHER PROJECT IN ANY MANNER WITHOUT THE EXPRESS WRITTEN CONSENT OF SAMTEC, INC.

DO NOT SCALE DRAWING

SHEET SCALE: 5:1



520 PARK EAST BLVD, NEW ALBANY, IN 47150  
 PHONE: 812-944-6733 FAX: 812-948-5047  
 e-Mail info@SAMTEC.com code 5332

DESCRIPTION:  
 0.4mm[.016] TERMINAL STRIP ASSEMBLY

DWG. NO.  
 ST4-XX-X.XX-X-D-X-XX-XR

BY: BRATCHER 3/21/2007 SHEET 4 OF 4