

DO NOT
SCALE FROM
THIS PRINT

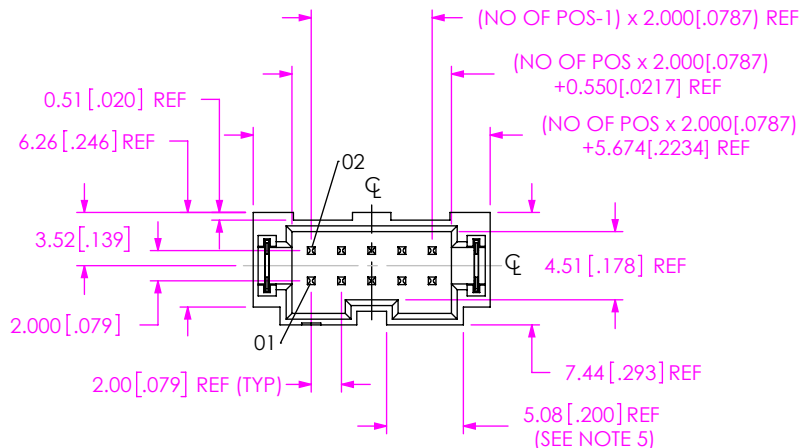

No OF POSITIONS
 **-.02, **-.03, **-.04, -.05, -.06,
 -.07, -.08, -.09, -.10, -.14, -.15,
 -.20, -.25, -.30, & -.50 (PER ROW)
 AVAILABLE AS STANDARD;
 OTHER SIZES BETWEEN -.05 THRU
 -.50 AVAILABLE AS ASO

LEAD STYLE
 -01

PLATING SPECIFICATION
 -L: 10µ" SELECTIVE GOLD IN CONTACT
 AREA, MATTE TIN ON TAIL
 (USE T-1S13-XX-L-2)
 -S: 30µ" SELECTIVE GOLD IN CONTACT
 AREA, MATTE TIN ON TAIL
 (USE T-1S13-XX-S-2)

ROW SPECIFICATION
 -D: DOUBLE ROW

TAIL OPTION
 -TH: THROUGH HOLE (SEE FIG 1)
 -RA: RIGHT ANGLE (SEE FIG 2)
 -SM: SURFACE MOUNT (SEE FIG 3, SHT 2)

PACKAGING
 BLANK: TUBES (SEE NOTE 7)
 -TR: TAPE & REEL (SEE NOTES 8 & 9)
 -FR: FULL REEL QTY TAPE & REEL
 (SEE NOTES 8 & 9)
 (-TR & -FR PACKAGING ARE AVAILABLE
 FOR -SM OPTION ONLY, NOT AVAILABLE
 IN -.02, -.03 OR -.04 POSITIONS)

PICK & PLACE OPTION
 -K: POLYIMIDE FILM (-SM OPTION ONLY)
 (USE K-DOT-.295-.406-.005, SEE FIG 4)
 (NOT AVAILABLE IN -.02, -.03 OR -.04 POSITIONS)

OPTION
 -DS: DUAL SCREW DOWN (SEE FIG 6, SHT 3)
 (FOR 1.57mm [.062] PCB)
 (AVAILABLE 5-30 POSITIONS ONLY)
 (NOT AVAILABLE WITH -RA, -WT OPTIONS)
 (USE T-1S13-04-X-2 WITH TH OPTION
 AND TI-M2-4-VSFM-T,
 USE T-1S13-20-X-2 WITH SM OPTION
 AND TI-M2-4-VSFM-T)
 -WT: WELD TAB
 (USE WT-25-07-T);
 (-SM, SEE FIG 3, SHT 2)
 (-TH, SEE FIG 5, SHT 2)
 (-RA, USE WT-81-01-T)

** = ONLY AVAILABLE WITH -SM-WT OR -RA-WT OPTIONS

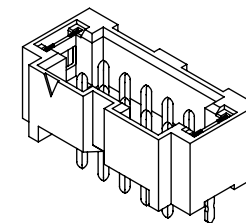
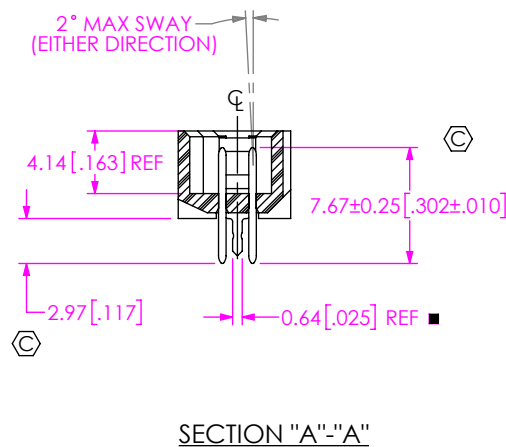
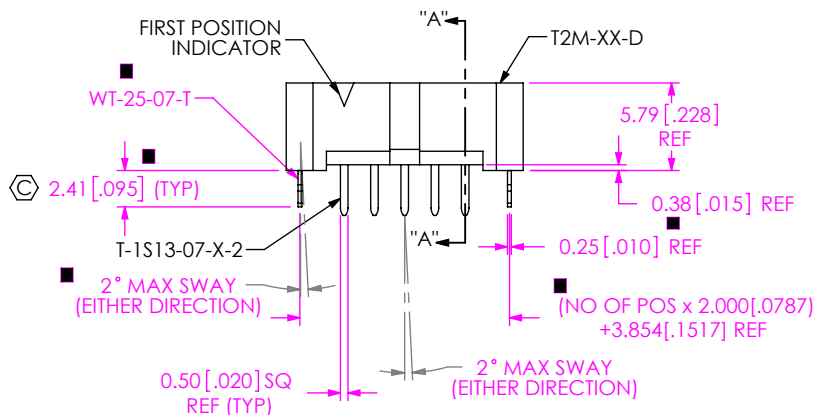

FIG 1
 T2M-105-01-X-D-TH-XX
 (■ = ONLY APPLICABLE WITH -WT OPTION)

NOTES:

1. Ⓢ REPRESENTS A CRITICAL DIMENSION.
2. MINIMUM PUSHOUT FORCE: 4.44N [1.0 LB].
3. POST HEIGHT VARIATION BETWEEN ANY TWO PINS: 0.13 [.005] MAXIMUM.
4. MAXIMUM PIN ROTATION IN BODY TO BE 2°.
5. DUAL POLARIZATION SLOT NOT AVAILABLE ON CONNECTOR WITH LESS THAN 5 POSITIONS.
6. MINIMUM RETENTION FORCE FOR WELD TABS: 4.44N [1.0 LB].
7. TUBES ARE STANDARD PACKAGING.
8. ORDERS WILL BE PACKAGED ACCORDING TO THE SAMTEC PACKAGING EFFICIENCY STANDARDS (SPES) FOUND ON WWW.SAMTEC.COM.
9. ATTACH LABEL TO EACH REEL.

UNLESS OTHERWISE SPECIFIED,
 DIMENSIONS ARE IN MILLIMETERS.
 TOLERANCES ARE:
 DECIMALS ANGLES
 X.X: ±0.3 [.01] 2°
 X.XX: ±0.13 [.005]
 X.XXX: ±0.051 [.0020]

PROPRIETARY NOTE
 * THIS DOCUMENT CONTAINS CONFIDENTIAL AND
 PROPRIETARY INFORMATION AND ALL DESIGN,
 MANUFACTURING, REPRODUCTION, USE, PATENT RIGHTS
 AND SALES RIGHTS ARE EXPRESSLY RESERVED BY SAMTEC,
 INC. THIS DOCUMENT SHALL NOT BE DISCLOSED, IN WHOLE
 OR PART, TO ANY UNAUTHORIZED PERSON OR ENTITY NOR
 REPRODUCED, TRANSFERRED OR INCORPORATED IN ANY
 OTHER PROJECT IN ANY MANNER WITHOUT THE EXPRESS
 WRITTEN CONSENT OF SAMTEC, INC.

MATERIAL: DO NOT SCALE DRAWING SHEET SCALE: 2:1
 INSULATOR: LCP, COLOR: BLACK
 TERMINAL: PHOS BRONZE
 WELD TAB: PHOS BRONZE
 KAPTON: POLYIMIDE FILM



520 PARK EAST BLVD, NEW ALBANY, IN 47150
 PHONE: 812-944-6733 FAX: 812-948-5047
 e-Mail info@SAMTEC.com code 55322

DESCRIPTION:
 2mm SHROUDED TERMINAL STRIP
 DWG. NO.
 T2M-1XX-XX-X-D-XX-XX-X-XX
 BY: J. BORGELT 3/23/09 SHEET 1 OF 3

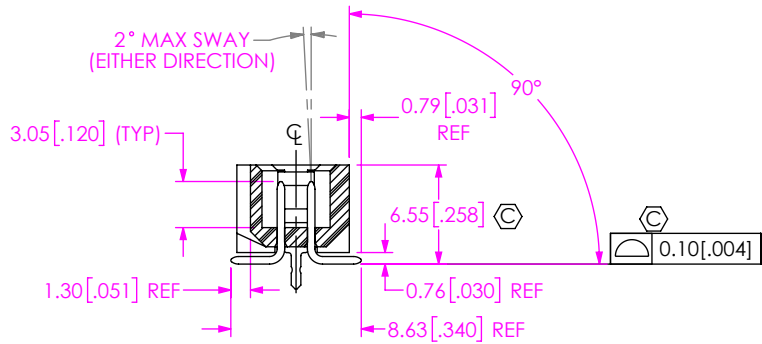
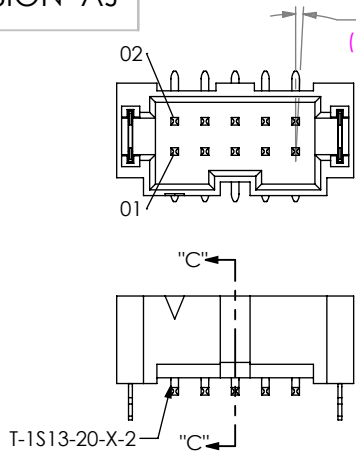

FIG 3
T2M-105-01-X-D-SM-WT SHOWN
(SAME AS FIG 1, EXCEPT AS SHOWN)

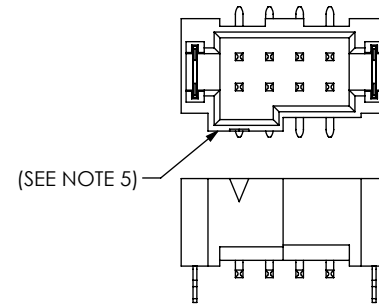
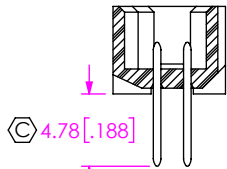
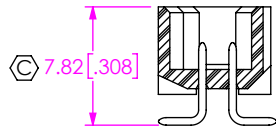

FIG 5
T2M-104-01-X-D-SM-WT
(SAME AS FIG 1, EXCEPT AS SHOWN)
(T2M-102-01-X-D-SM-WT SIMILAR)



-SM IN PROCESS 1



-SM IN PROCESS 2

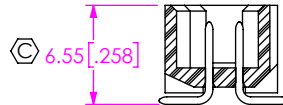

-SM IN PROCESS 3

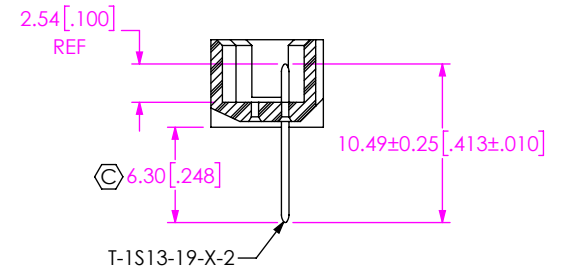

-RA IN PROCESS 1

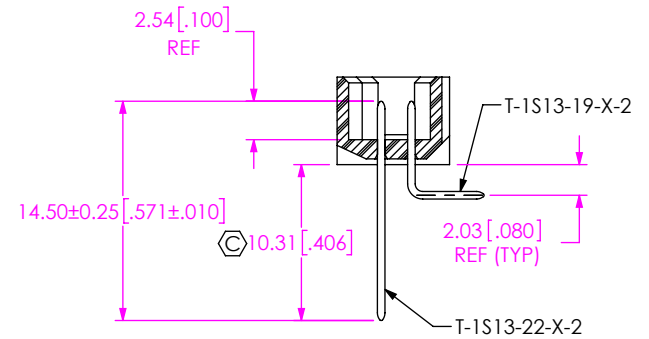

-RA IN PROCESS 2

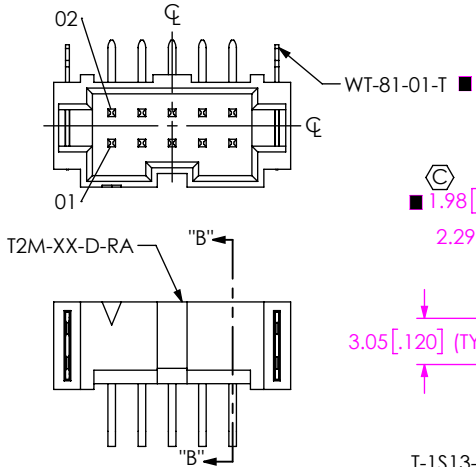
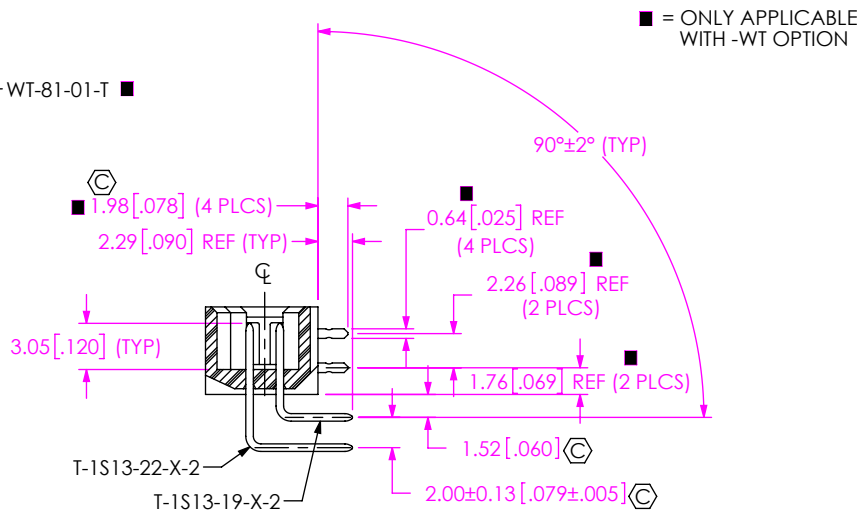

FIG 2
T2M-105-01-X-D-RA-XX
(SAME AS FIG 1, EXCEPT AS SHOWN)



SECTION "B"-"B"

PROPRIETARY NOTE
THIS DOCUMENT CONTAINS CONFIDENTIAL AND PROPRIETARY INFORMATION AND ALL DESIGN, MANUFACTURING, REPRODUCTION, USE, PATENT RIGHTS AND SALES RIGHTS ARE EXPRESSLY RESERVED BY SAMTEC, INC. THIS DOCUMENT SHALL NOT BE DISCLOSED, IN WHOLE OR PART, TO ANY UNAUTHORIZED PERSON OR ENTITY NOR REPRODUCED, TRANSFERRED OR INCORPORATED IN ANY OTHER PROJECT IN ANY MANNER WITHOUT THE EXPRESS WRITTEN CONSENT OF SAMTEC, INC.

DO NOT SCALE DRAWING

SHEET SCALE: 2:1



520 PARK EAST BLVD. NEW ALBANY, IN 47150
PHONE: 812-944-6733 FAX: 812-948-5047
e-Mail: info@SAMTEC.com code 55322

DESCRIPTION:
2mm SHROUDED TERMINAL STRIP
DWG. NO.
T2M-1XX-XX-X-D-XX-XX-X-XX
BY: J. BORGELT 3/23/09 SHEET 2 OF 3

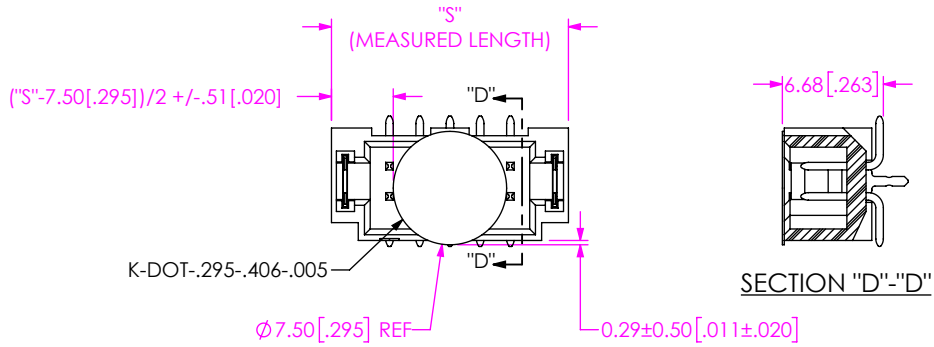

FIG 4
T2M-105-01-X-D-SM-K SHOWN
(FOR SURFACE MOUNT OPTION ONLY)

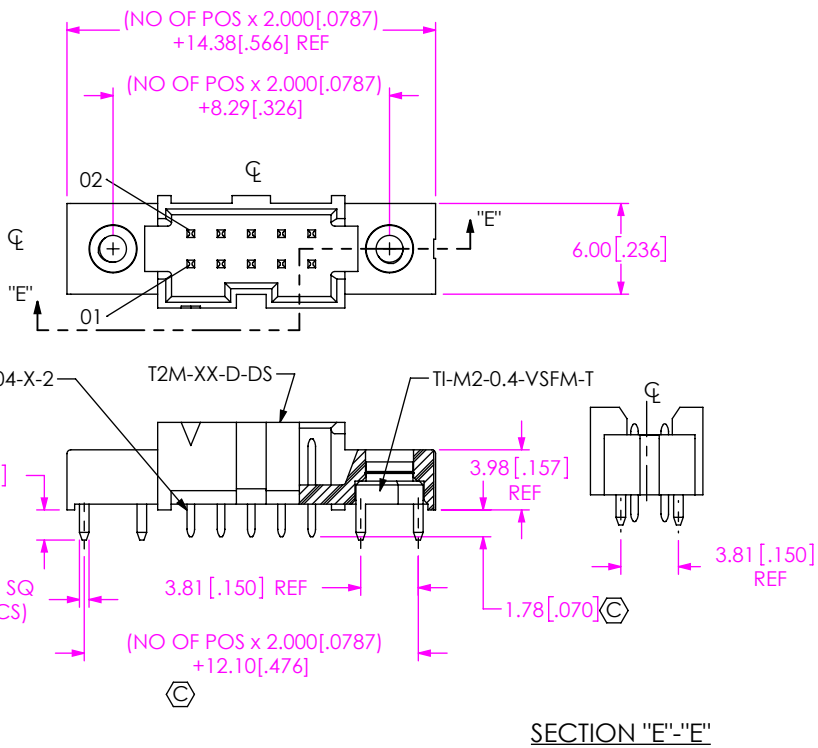
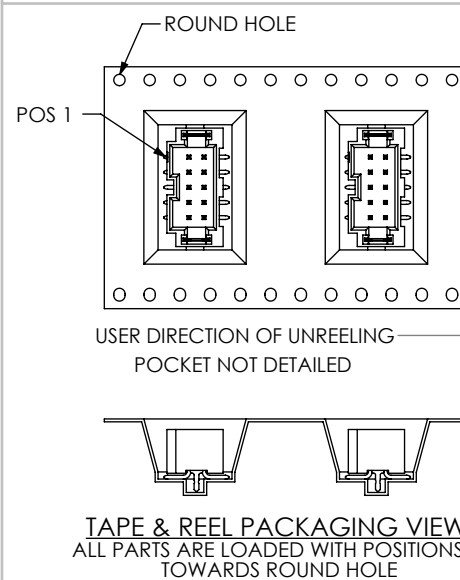

FIG 6
T2M-105-01-X-D-TH-DS SHOWN
(SAME AS FIG 1, EXCEPT AS SHOWN)
(ONLY AVAILABLE WITH -TH & -SM OPTION)

F:\DWG\MISC\MKTG\T2M-1XX-XX-X-D-XX-XX-X-XX-MKT.SLDDRW

TABLE 1

OPTIONS	PACKAGING TUBE	PLUG
-TH, -TH-WT	PT-1-24-01-103	TP-09
-SM, -SM-WT	PT-T2M002	TP-09
-RA, -RA-WT	PT-T2M001	TP-07
-TH-DS	PT-1-24-01-103	TP-09
-SM-DS	PT-T2M002	TP-09



TAPE & REEL PACKAGING VIEW
ALL PARTS ARE LOADED WITH POSITIONS 1
TOWARDS ROUND HOLE

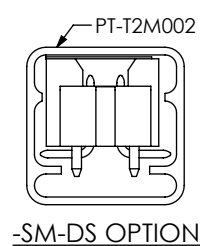
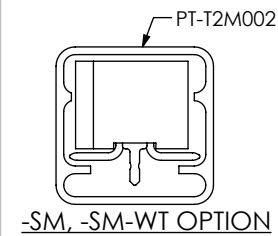
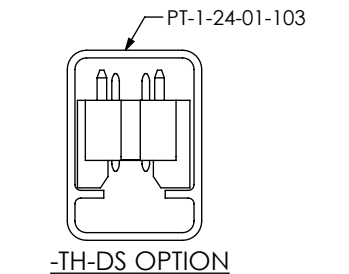
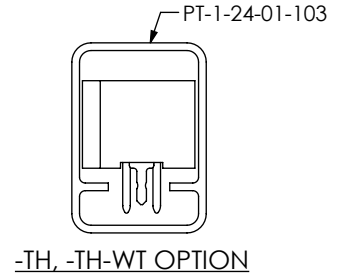
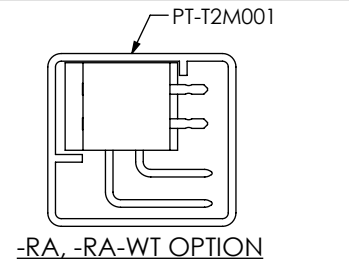

-SM, -SM-WT OPTION

-SM-DS OPTION

PACKAGING
ALL PARTS ARE LOADED WITH POSITIONS 1
TOWARDS ARROW

PROPRIETARY NOTE
THIS DOCUMENT CONTAINS CONFIDENTIAL AND PROPRIETARY INFORMATION AND ALL DESIGN, MANUFACTURING, REPRODUCTION, USE, PATENT RIGHTS AND SALES RIGHTS ARE EXPRESSLY RESERVED BY SAMTEC, INC. THIS DOCUMENT SHALL NOT BE DISCLOSED, IN WHOLE OR PART, TO ANY UNAUTHORIZED PERSON OR ENTITY NOR REPRODUCED, TRANSFERRED OR INCORPORATED IN ANY OTHER PROJECT IN ANY MANNER WITHOUT THE EXPRESS WRITTEN CONSENT OF SAMTEC, INC.

DO NOT SCALE DRAWING

SHEET SCALE: 2:1



520 PARK EAST BLVD, NEW ALBANY, IN 47150
PHONE: 812-944-6733 FAX: 812-948-5047
e-Mail info@SAMTEC.com code 55322

DESCRIPTION:
2mm SHROUDED TERMINAL STRIP
DWG. NO.
T2M-1XX-XX-X-D-XX-XX-X-XX
BY:
J. BORGELT 3/23/09 SHEET 3 OF 3