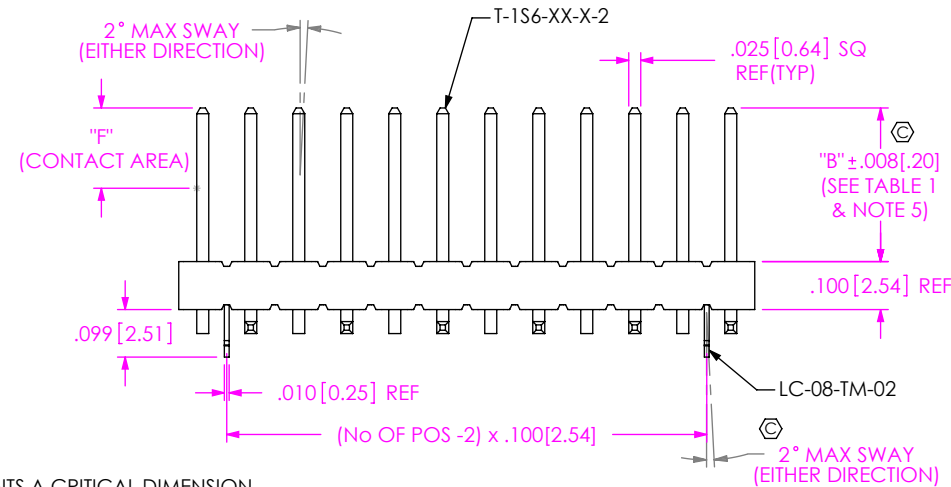
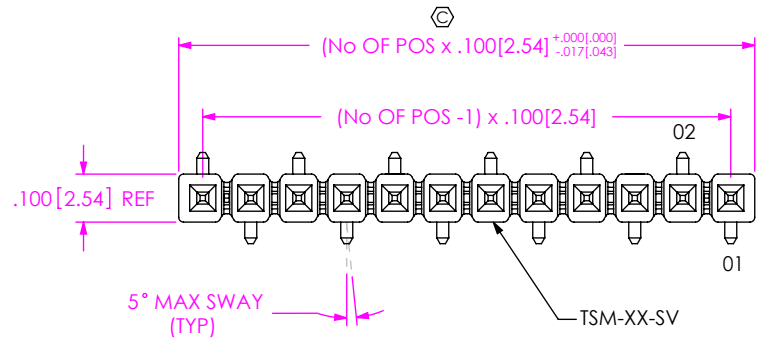

TABLE 1						
STYLE	"B"	"C"	"D" MAX	"E"	"F"	TERMINAL
-01	.230[5.84]	.280[7.11]	.208[5.28]	.445[11.30]	.165 [4.19]	T-1S6-16-X-2
-02	.320[8.13]	.370[9.40]	.205[5.20]	.530[13.46]	.165 [4.19]	T-1S6-08-X-2
-03	.420[10.67]	.470[11.94]	.205[5.20]	.630[16.00]	.165 [4.19]	T-1S6-15-X-2
-04	.120[3.05]	.270[6.86]	.208[5.28]	.335[8.51]	.050 [1.27]	T-1S6-21-X-2
-05	.075[1.91]	.270[6.86]	.223[5.66]	.300[7.62]	.050 [1.27]	T-1S6-18-X-2



TSM-1XX-XX-XXX-SV-XX-XXX-X-XX

No OF POSITIONS  
-02 THRU -50

LEAD STYLE  
SEE TABLE 1

PLATING SPECIFICATION

- T: MATT TIN CONTACT AND TAIL
- S: SELECTIVE, 30 Au / 50 Ni MIN ON CONTACT, MATTE TIN TAIL
- G: GOLD, 10 Au / 50 Ni MIN ON CONTACT, 3 Au / 50 Ni MIN ON TAIL
- L: LIGHT SELECTIVE, 10 Au / 50 Ni MIN ON CONTACT, MATTE TIN ON TAIL
- F: FLASH SELECTIVE, 3 Au / 50 Ni MIN ON CONTACT, MATTE TIN TAIL
- H: HEAVY GOLD, 30 Au / 50 Ni MIN ON CONTACT, 3 Au / 50 Ni MIN ON TAIL
- TL: TIN / LEAD (90/10+/-5%) CONTACT AND TAIL [LEAD STYLE -01 & -02 ONLY]
- STL: SELECTIVE, 30 Au / 50 Ni MIN ON CONTACT, TIN/LEAD (90/10+/-5%) TAIL [LEAD STYLE -01 & -02 ONLY]
- TM: MATTE TIN CONTACT AND TAIL
- SM: SELECTIVE, 30 Au / 50 Ni MIN ON CONTACT, MATTE TIN TAIL
- LM: LIGHT SELECTIVE, 10 Au / 50 Ni MIN ON CONTACT, MATTE TIN TAIL
- FM: FLASH SELECTIVE, 3 Au / 50 Ni MIN ON CONTACT, MATTE TIN TAIL
- SS: STRIPE SELECTIVE, 30 Au / 50 Ni MIN ON CONTACT, MATTE TIN TAIL (SEE NOTE 9)

PACKAGING

- BLANK: TUBE OR LAYER (SEE NOTE 4, SHT 2)
- TR: TAPE & REEL (SEE NOTES 7, 13 & 14)
- FR: FULL REEL QTY. TAPE & REEL (SEE NOTES 7, 13 & 14)
- (-XR IS AVAILABLE FOR -02 THRU -22 POS)

PICK & PLACE OPTION

- P: PICK & PLACE PAD (SEE FIG 3) [USE PPP-07] (4 POS MINIMUM OR -02 & -03 POS WITH -TR & -FR) (SEE NOTE 7)

OPTION #2

POLARIZED POSITION: SPECIFY PIN OMITTED

OPTION #1

- LC: LOCKING CLIP (SEE FIG 1) (SEE NOTE 8) [USE LC-08-TM-02] (-03 THRU -36 POS: 2 PER STRIP, -02 POS: 1 PER STRIP)
- A: ALIGNMENT PIN (SEE FIG 2)

ROW SPECIFICATION

- SV: SINGLE VERTICAL (USE TSM-XX-SV-XX)

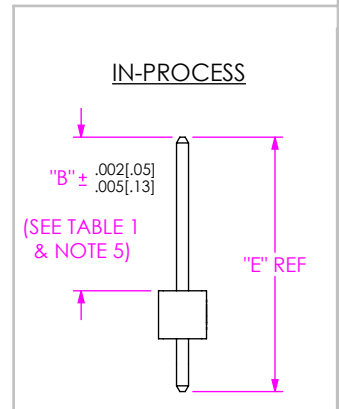
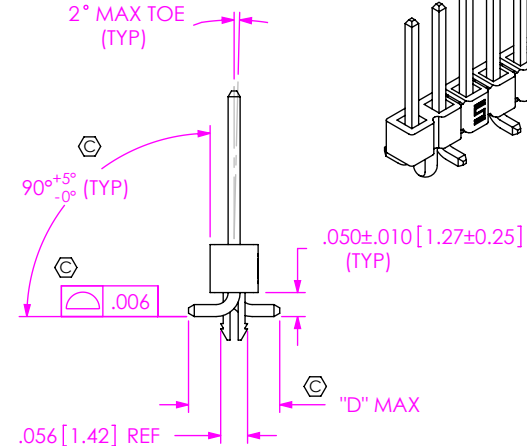
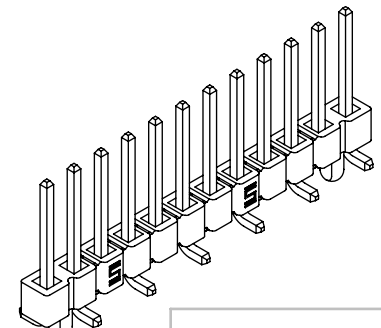

NOTES:

1. Ⓢ REPRESENTS A CRITICAL DIMENSION.
2. COPLANARITY TO BE WITHIN .006[.15].
3. BURR ALLOWANCE: .0015[.038] MAX.
4. MAXIMUM CUT FLASH: .015[.38] MAXIMUM ON TOP & SIDES OF BODY AND .030[.76] MAXIMUM ON SURFACE MOUNT SIDE OF BODY.
5. POST HEIGHT VARIATION BETWEEN ANY TWO PINS: .005[.13] MAXIMUM.
6. MAXIMUM ALLOWABLE BOW: .002[.05] INCH/INCH AFTER ASSEMBLY.
7. LEADS MAY NOT BE VISIBLE FOR CUSTOMER VISUAL INSPECTION WITH -P OPTION ON SMALLER POSITIONS PARTS.
8. DUE TO THE HIGH AMOUNT OF INSERTION FORCE NEEDED, THE -LC OPTION IS NOT COMPATIBLE WITH AUTO PLACEMENT. SAMTEC RECOMMENDS MANUAL PLACEMENT FOR ALL ASSEMBLIES WITH THE -LC OPTION.
9. -01 LEAD STYLE ONLY, MATES WITH SSW, SSQ, BCS, SSM, ESW, ESG.
10. MINIMUM PUSHOUT FORCE: 2LB. [8.90 N].
11. NOTE DELETED.
12. NOTE DELETED.
13. ORDERS WILL BE PACKAGED ACCORDING TO THE SAMTEC PACKAGING EFFICIENCY STANDARDS (SPES) FOUND ON WWW.SAMTEC.COM
14. ATTACH LABEL TO EACH REEL.

FIG 1

TSM-112-02-XXX-SV-LC SHOWN

UNLESS OTHERWISE SPECIFIED, DIMENSIONS ARE IN INCHES.

TOLERANCES ARE:

DECIMALS	ANGLES
.XX: ±.01 [.3]	2°
.XXX: ±.005 [.13]	
.XXXX: ±.0020 [.051]	

PROPRIETARY NOTE

THIS DOCUMENT CONTAINS CONFIDENTIAL AND PROPRIETARY INFORMATION AND ALL DESIGN, MANUFACTURING, REPRODUCTION, USE, PATENT RIGHTS AND SALES RIGHTS ARE EXPRESSLY RESERVED BY SAMTEC, INC. THIS DOCUMENT SHALL NOT BE DISCLOSED, IN WHOLE OR PART, TO ANY UNAUTHORIZED PERSON OR ENTITY NOR REPRODUCED, TRANSFERRED OR INCORPORATED IN ANY OTHER PROJECT IN ANY MANNER WITHOUT THE EXPRESS WRITTEN CONSENT OF SAMTEC, INC.

MATERIAL: DO NOT SCALE DRAWING

INSULATOR:  
LCP, UL 94 VO  
COLOR: BLACK

TERMINAL: PHOS BRONZE

F:\DWG\MISC\MKTG\TSM-1XX-XX-XXX-SV-XX-XXX-X-XX-MKT.SLDDRW

SHEET SCALE: 2.5:1

DESCRIPTION:



520 PARK EAST BLVD, NEW ALBANY, IN 47150  
PHONE: 812-944-6733 FAX: 812-948-5047  
e-Mail: info@SAMTEC.com code 55322

SINGLE ROW .100 SMT ASSEMBLY

DWG. NO. TSM-1XX-XX-XXX-SV-XX-XXX-X-XX

BY: DEAN P 8/21/2002 SHEET 1 OF 2

FIG 3

-P: PICK & PLACE PAD OPTION  
4 POSITION MINIMUM  
[PLACE PAD ON CENTERLINE AS SHOWN]

"A" = (No OF POSITIONS x .100[2.54] - .400[10.16])/2  
(SEE TABLE 3)

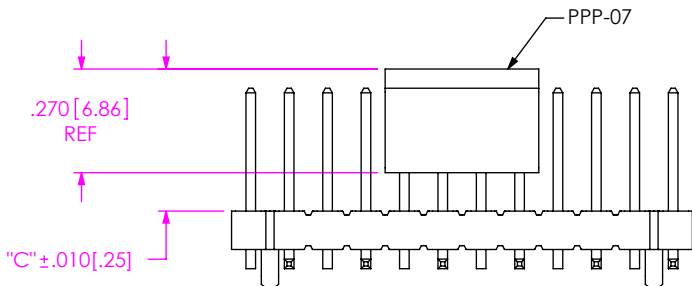
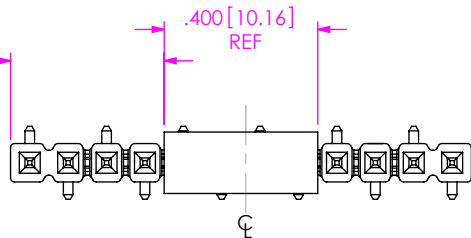

"A" =  $\frac{\text{No OF POSITIONS} \times .100[2.54] - .400[10.16]}{2}$

POSITION	TOLERANCE
-02 THRU -04	"A" +/- .015
-05 THRU -50	"A" +/- .020

FIG 2

-A: ALIGNMENT PIN OPTION  
TSM-112-02-X-SV-A SHOWN  
[DIFFERENT AS SHOWN, OTHERWISE SAME AS FIG 1]

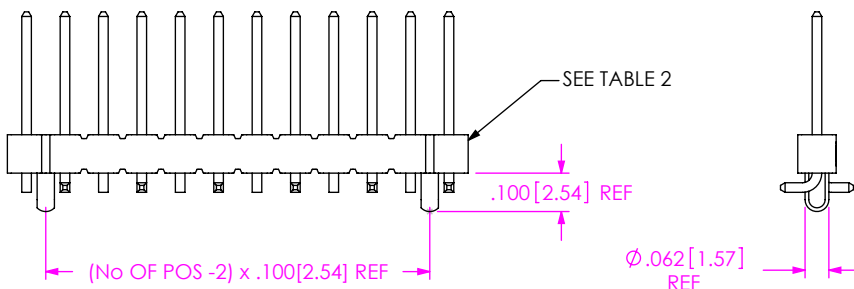

POSITION	USE BODY
-3	TSM-03-SV-A
-02 & -04 THRU -50	TSM-XX-SV-X

PACKAGING TABLE

STYLE	OPTION	TUBE	PLUG
-01	----	PT-1-24-02-29 (SEE NOTE 3)	TP-24
-02, -04, -05	----	PT-1-24-02-29 (SEE NOTE 3)	TP-24
-01, -02, -04, -05	-LC, -A	PT-1-24-02-29 (SEE NOTE 3)	TP-24
-01, -04, -05	-P	PT-1-24-05-29	TP-03
-01, -04, -05	-LC-P, -A-P	PT-1-24-05-29	TP-03
-02	-P	PT-1-24-13-29	TP-03
-02	-LC-P, -A-P	PT-1-24-13-29	TP-03
-03	----	PT-1-24-10-29 (SEE NOTE 3)	TP-24
-03	-LC, -A	PT-1-24-10-29 (SEE NOTE 3)	TP-24
-03	-P	PT-1-24-14-29	TP-09
-03	-LC-P, -A-P	PT-1-24-14-29	TP-09

NOTES:

1. LOAD PARTS POSITION 1 FIRST IN SAME DIRECTION AS ARROW.
2. NOTE DELETED
3. PACKAGE POSITIONS -04 THRU -36.
4. POLARIZED 4 POSITION PARTS WITHOUT PADS ARE TO BE LAYER PACKAGED OR PACKAGED IN TAPE AND REEL.

FIG 4  
TUBE PACKAGING

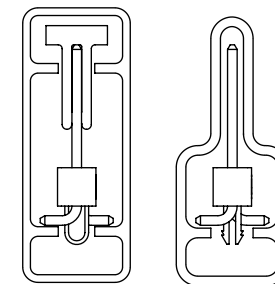
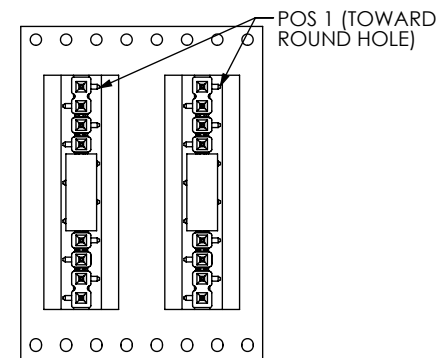
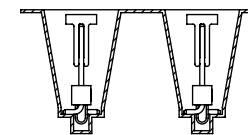

FIG 5

-TR: TAPE & REEL PACKAGNG OPTION



USER DIRECTION OF UN-REELING  
POCKET NOT DETAILED



F:\DWG\MISC\MKTG\TSM-1XX-XX-XXX-SV-XX-XXX-X-XX-MKT.SLDDRW

PROPRIETARY NOTE

THIS DOCUMENT CONTAINS CONFIDENTIAL AND PROPRIETARY INFORMATION AND ALL DESIGN, MANUFACTURING, REPRODUCTION, USE, PATENT RIGHTS AND SALES RIGHTS ARE EXPRESSLY RESERVED BY SAMTEC, INC. THIS DOCUMENT SHALL NOT BE DISCLOSED, IN WHOLE OR PART, TO ANY UNAUTHORIZED PERSON OR ENTITY NOR REPRODUCED, TRANSFERRED OR INCORPORATED IN ANY OTHER PROJECT IN ANY MANNER WITHOUT THE EXPRESS WRITTEN CONSENT OF SAMTEC, INC.



520 PARK EAST BLVD, NEW ALBANY, IN 47150  
PHONE: 812-944-6733 FAX: 812-948-5047  
e-Mail info@SAMTEC.com code 55322

DO NOT SCALE DRAWING

SHEET SCALE: 2:1

DESCRIPTION:  
SINGLE ROW .100 SMT ASSEMBLY

DWG. NO.  
TSM-1XX-XX-XXX-SV-XX-XXX-X-XX

BY: DEAN P 8/21/2002 SHEET 2 OF 2