

XQXX-XXX-XXXX-SPD-STR-X-X

ALL DIMENSIONS REF
DO NOT SCALE
FROM THIS PRINT

SERIES	"D"	"J"
EQCD	0.501 [12.73]	0.775 [19.69]
SQCD	0.625 [15.88]	0.775 [19.69]
HQCD	0.751 [19.08]	0.775 [19.69]
EQDP	0.525 [13.34]	0.775 [19.69]
* HQDP	N/A	0.875 [22.23]

WIRING OPTION 3
POSITION 1 TO POSITION N-1

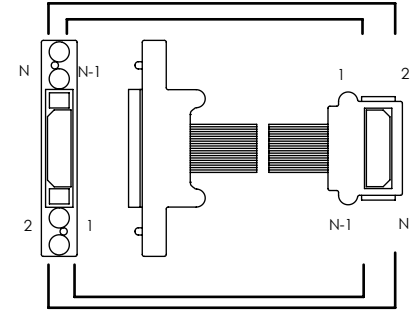

WIRING OPTION 4
POSITION 1 TO POSITION N

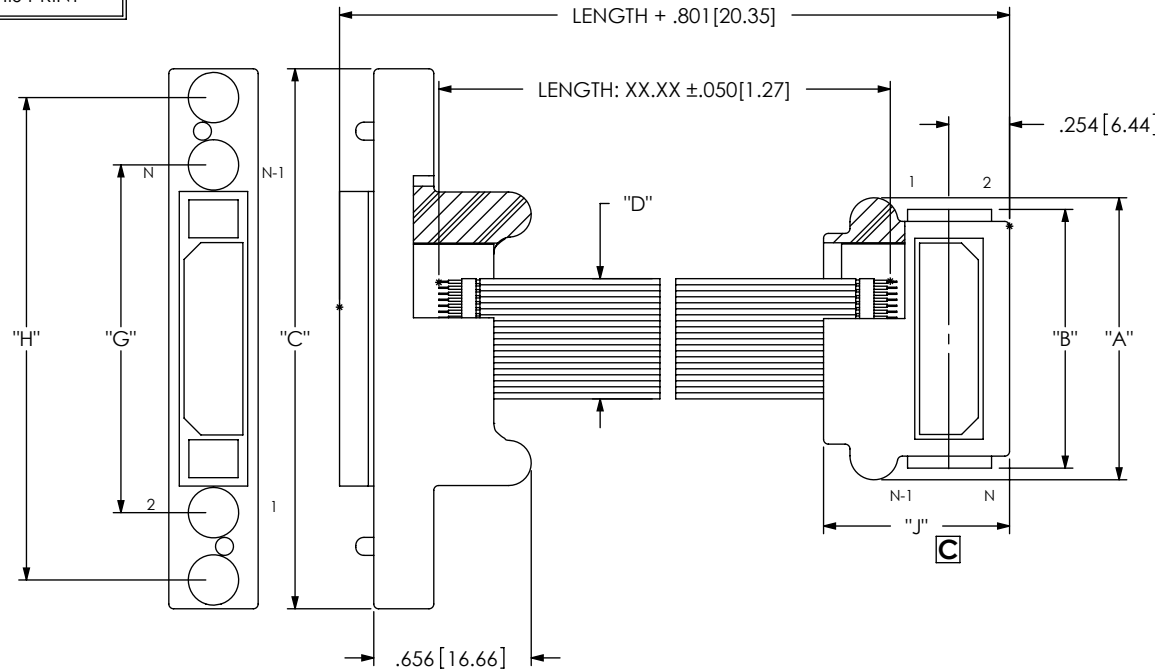
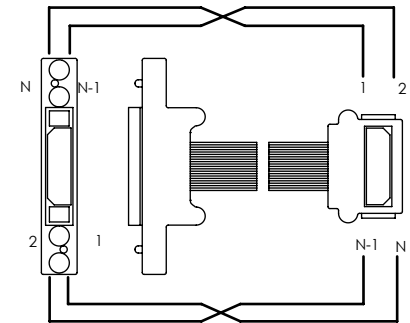

FIRST END

SECOND END

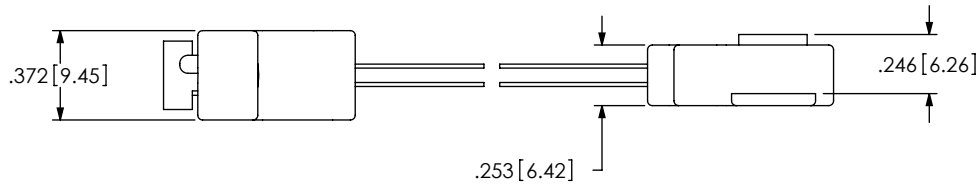

ONLY APPLICABLE FOR SCREW-DOWN END OPTIONS (SECOND END ONLY)

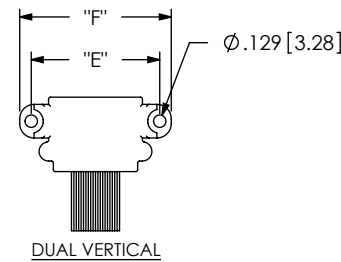

EQCD No. OF POSITIONS	SQCD No. OF POSITIONS	HQCD No. OF POSITIONS	EQDP No. OF POSITIONS	* HQDP No. OF POSITIONS	"E"	"F"
-020	-025	-030	-014	N/A	1.339 [34.00]	1.579 [40.10]
-040	-050	-060	-028	N/A	2.126 [54.00]	2.366 [60.10]
-060	-075	-090	-042	N/A	2.913 [74.00]	3.154 [80.10]
-080	-100	-120	-056	N/A	3.701 [94.00]	3.941 [100.10]

EQCD No. OF POSITIONS	SQCD No. OF POSITIONS	HQCD No. OF POSITIONS	EQDP No. OF POSITIONS	* HQDP No. OF POSITIONS	"A"	"B"	"C"	G	H
-020	-025	-030	-014	N/A	1.175 [29.85]	1.078 [27.38]	2.25 [57.15]	1.449 [36.80]	2.010 [51.05]
-040	-050	-060	-028	N/A	1.963 [49.85]	1.866 [47.40]	3.038 [77.17]	2.237 [56.80]	2.798 [71.07]
-060	-075	-090	-042	N/A	2.750 [69.85]	2.653 [67.39]	3.826 [97.18]	3.024 [76.80]	3.585 [91.06]
-080	-100	-120	-056	N/A	3.538 [89.85]	3.441 [87.39]	N/A	N/A	N/A

* = NOT TOOLED

PROPRIETARY NOTE

THIS DOCUMENT CONTAINS INFORMATION CONFIDENTIAL AND PROPRIETARY TO SAMTEC, INC. AND SHALL NOT BE REPRODUCED OR TRANSFERRED TO OTHER DOCUMENTS OR DISCLOSED TO OTHERS OR USED FOR ANY PURPOSE OTHER THAN THAT WHICH IT WAS OBTAINED WITHOUT THE EXPRESSED WRITTEN CONSENT OF SAMTEC, INC.



520 PARK EAST BLVD, NEW ALBANY, IN 47150
PHONE: 812-944-6733 FAX: 812-948-5047
e-Mail: info@SAMTEC.com code: 55322

SHEET SCALE: 1:25:1

DESCRIPTION:

QSX / QSX CABLE ASSEMBLY

DWG. NO.

XQXX-XXX-XXXX-SPD-STR-X-X

BY: D FRALEY 05/24/2006 SHEET 1 OF 1