

Series: .100" (2,54 mm) Mini Mate™ Double / Single Row Discrete Wire Cable Assembly, Socket / Terminal

MMSD(T)/MMSS(T)  
Series Cable Assemblies

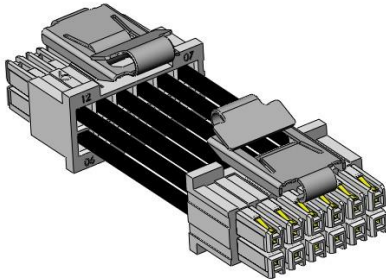

MMTD(T)/MMTS(T)  
Series Cable Assemblies

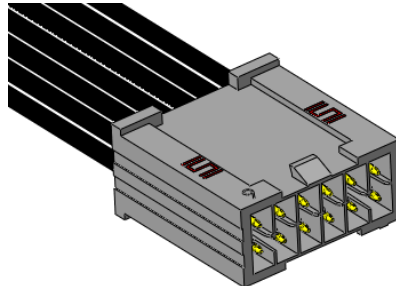

MRTD(T) Cable Assemblies  
Cable Assemblies

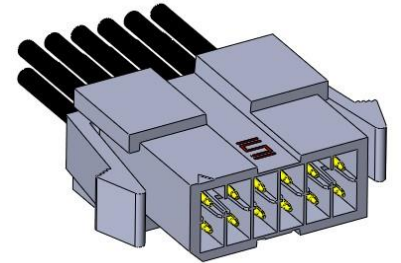

CC79 Crimp Contact

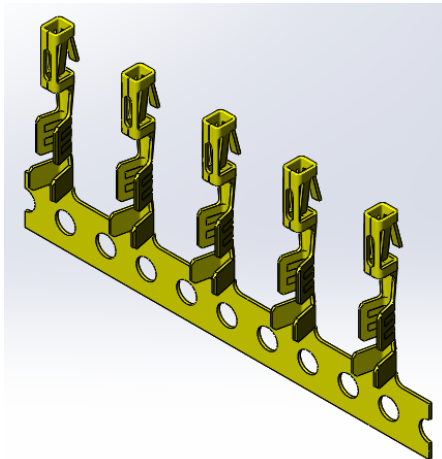

T1M74 Crimp Terminal

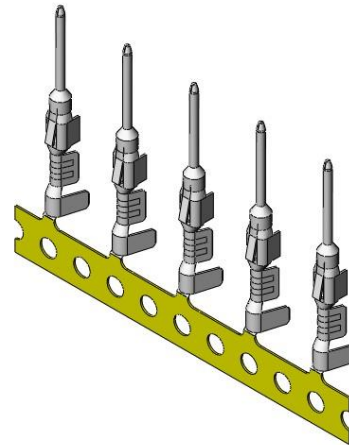

IPD1 Series Socket Housings

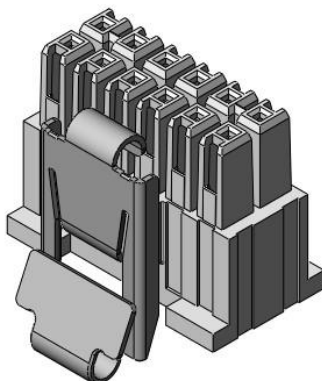

IPM1 Series Terminal Housings

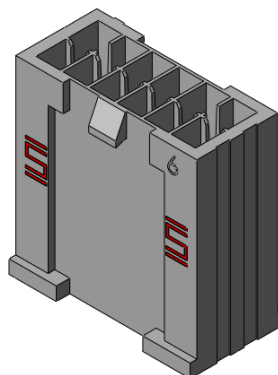

IPR1 Series Terminal Housings

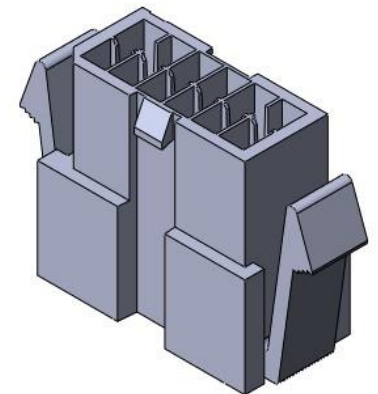

**Series:** .100" (2,54 mm) Mini Mate™ Double / Single Row Discrete Wire Cable Assembly, Socket / Terminal

### 1.0 SCOPE

- 1.1 This specification covers performance, testing and quality requirements for Samtec .100" (2,54mm) Mini Mate™ Double / Single Row Discrete Wire Cable Assembly Socket / Terminal System. Testing was performed using a dual row, female MMSD Series cable assembly mated to a IPL1 Series terminal strip unless otherwise noted.

### 2.0 DETAILED INFORMATION

- 2.1 Product prints, footprints, catalog pages, test reports and other specific, detailed information can be found at <http://www.samtec.com/cable-systems/discrete-wire.aspx#100MiniMate>.

### 3.0 PRODUCT DESCRIPTION

#### 3.1 Product Series

| ITEM              | SOCKET                 | TERMINAL             |
|-------------------|------------------------|----------------------|
| Crimp Contacts    | CC79R, CC79L           | T1M74-L,T1M74-R      |
| Housings          | IPD1                   | IPM1, IPR1           |
| Mating connectors | IPL1, MMTD(T), MRTD(T) | MMSD(T),MMSS(T),IPD1 |
| Cable Assemblies  | MMSD(T),MMSS(T),IPD1   | MRTD                 |

#### 3.2 Materials and Platings

| ITEM  | SOCKET                        | TERMINAL                                |
|---|-------------------------------|---|
| Contact Material                            | Phosphor Bronze               | Phosphor Bronze                         |
| Contact Plating                             | Au over 50u" Ni               | Au over 50u" Ni                         |
| Housing Material                            | Natural Nylon,<br>White Nylon | White Zytel PA66,<br>Natural Zytel PA66 |
| Insulation Material (Cable Assemblies only) | PVC, or Teflon                | PVC, or Teflon                          |

#### 3.3 Agency Approvals

| ITEM                | SOCKET              | TERMINAL            |
|---------------------|---------------------|---------------------|
| UL File Numbers     | E111594             | E111594             |
| Flammability Rating | 94V-0               | 94V-2               |
| RoHS                | RoHS Compliant      | RoHS Compliant      |
| REACH               | REACH 114 Compliant | REACH 114 Compliant |

**Series:** .100" (2,54 mm) Mini Mate™ Double / Single Row Discrete Wire Cable Assembly, Socket / Terminal

#### 4.0 TESTING

**4.1 Current Rating:** 2.9 A (One Pin Powered Per Row)

**4.2 Voltage Rating:** 275 VAC

**4.3 Operating Temperature Range:**

Components: -55°C to +125°C

Cable Assembly with PVC Cable: -10°C to +80°C

Cable Assembly with Teflon Cable: -40°C to +125°C

**4.4 Operating Humidity Range:** 90% to 95% (Per EIA-364-31)

**4.5 Electrical**

| ITEM                      | TEST CONDITION                                      | REQUIREMENT                                | STATUS |
|---------------------------|---|--|--------|
| Withstanding Voltage      | EIA-364-20 (No Flashover, Spark-over, or Breakdown) | 825 VAC                                    | Pass   |
| Insulation Resistance     | EIA-364-21 (1000 MΩ minimum)                        | 5, 000 MΩ                                  | Pass   |
| Contact Resistance (LLCR) | EIA-364-23  | Δ15 mΩ maximum (Samtec defined)/ No damage | Pass   |

**4.6 Mechanical**

| ITEM             | TEST CONDITION  | REQUIREMENT  | STATUS |
|------------------|---|--|--------|
| Durability       | EIA-364-09C   | 100 cycles (10u" Au)   | Pass   |
| Random Vibration | EIA-364-28 Condition V, Letter B 7.56 G 'RMS', 50 to 2000 Hz, 2 hours per axis, 3 axis total , PSD 0.04 | Visual Inspection: No Damage<br>LLCR: Δ 15 mΩ maximum<br>Event Detection: No interruption > 50 Nanoseconds | Pass   |
| Mechanical Shock | EIA-364-27 100 G, 6 milliseconds, sawtooth wave, 11.3 fps, 3 shocks/direction, 3 axis (18 total shocks) | Visual Inspection: No Damage<br>LLCR: Δ 15 mΩ maximum<br>Event Detection: No interruption > 50 Nanoseconds | Pass   |
| Normal Force     | EIA-364-04  | 30 grams minimum for gold interface  | Pass   |

**Series:** .100" (2,54 mm) Mini Mate™ Double / Single Row Discrete Wire Cable Assembly, Socket / Terminal

#### 4.7 Environmental

| ITEM                      | TEST CONDITION  | REQUIREMENT  | STATUS |
|---------------------------|---|--|--------|
| Thermal Shock             | EIA-364-32<br>Thermal Cycles: 100 (30 minute dwell)<br>Hot Temp: 85°C<br>Cold Temp: -55°C<br>Hot/Cold Transition: Immediate                 | Visual Inspection: No Damage<br>LLCR: $\Delta$ 15 m $\Omega$<br>DWV: 825 VAC<br>IR: >15,000 M $\Omega$ | Pass   |
| Thermal Aging (Temp Life) | EIA-364-17<br>Test Condition 4 @ 105°C<br>Condition B for 250 hours   | Visual Inspection: No Damage<br>LLCR: $\Delta$ 15 m $\Omega$<br>DWV: 825 VAC<br>IR: >15,000 M $\Omega$ | Pass   |
| Cyclic Humidity           | EIA-364-31<br>Test Temp: 25°C to 65°C<br>Relative Humidity: 90 to 95%<br>Test Duration: 240 hours   | Visual Inspection: No Damage<br>LLCR: $\Delta$ 15 m $\Omega$<br>DWV: 825 VAC<br>IR: >15,000 M $\Omega$ | Pass   |
| Gas Tight                 | EIA-364-36<br>Gas Exposure: Nitric Acid Vapor<br>Duration: 60 min.<br>Drying Temp.: 50°C +/- 3°C<br>Measurements: Within 1 hour of Exposure | LLCR: $\Delta$ 15 m $\Omega$   | Pass   |

## 5.0 MATED SYSTEM

**5.1 Latching Features** – Optional squeeze latches assure positive engagement for cable assemblies.

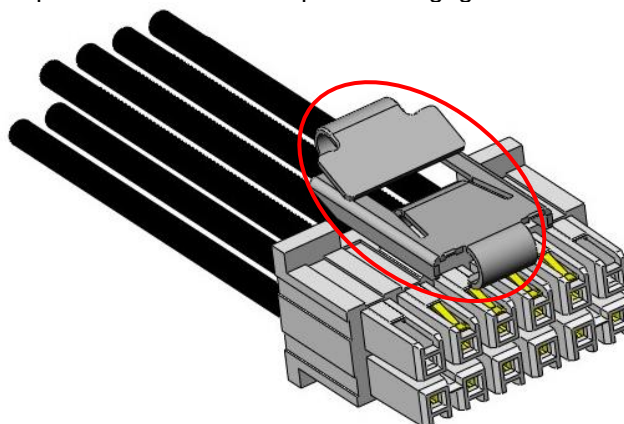

**Series:** .100" (2,54 mm) Mini Mate™ Double / Single Row Discrete Wire Cable Assembly, Socket / Terminal

### 5.2 Mated Views

Mated view information can be found at link below:

<https://suddendocs.samtec.com/prints/mmsdx%20mated%20document.pdf>

**5.3 Mating Angle Requirements:** Cable must be axially aligned to connector when mated and un-mated.

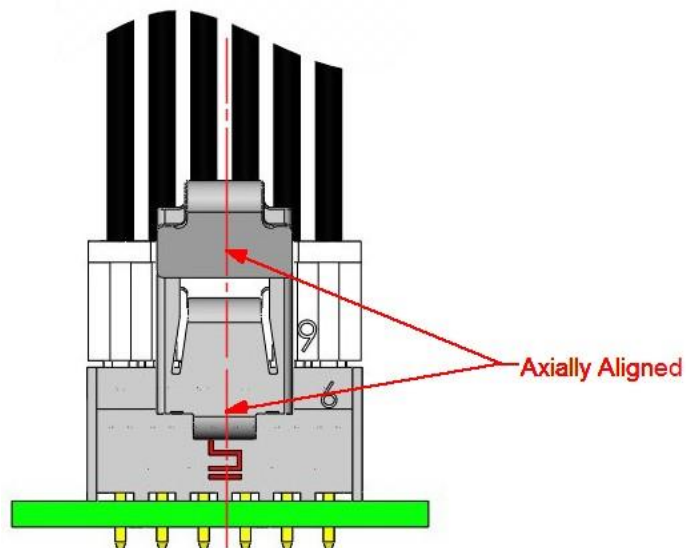

### 6.0 CRIMP RECOMMENDATIONS AND CABLE PREPARATION

Crimp recommendation and cable preparation can be found on the links below:

<https://suddendocs.samtec.com/prints/cc79x-xxxx-xx-x-mkt.pdf>

<https://suddendocs.samtec.com/prints/t1m74-x-xx-x-mkt.pdf>

### 7.0 APPLICATION INFORMATION

**7.1 Cable Management:** Samtec recommends some form of cable management to prevent non-axial forces being applied to the connector.

#### 7.2 Application Tools

Application tooling information can be found at link below:

<http://www.samtec.com/tooling.aspx#filter=100MiniMate>

Series: .100" (2,54 mm) Mini Mate™ Double / Single Row Discrete Wire Cable Assembly, Socket / Terminal

**7.3 PK-79 Polarizing Insert**

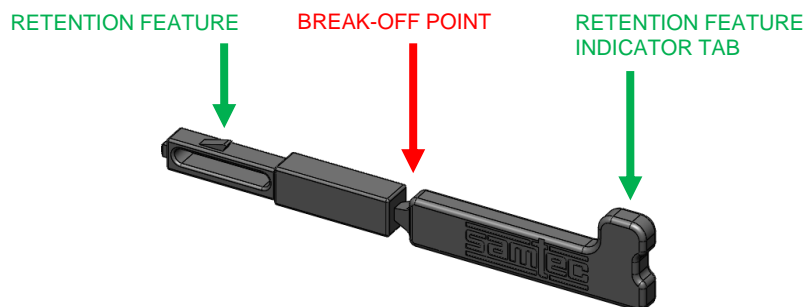

**7.4.1 PK-79 Polarizing IPD1-07-D**

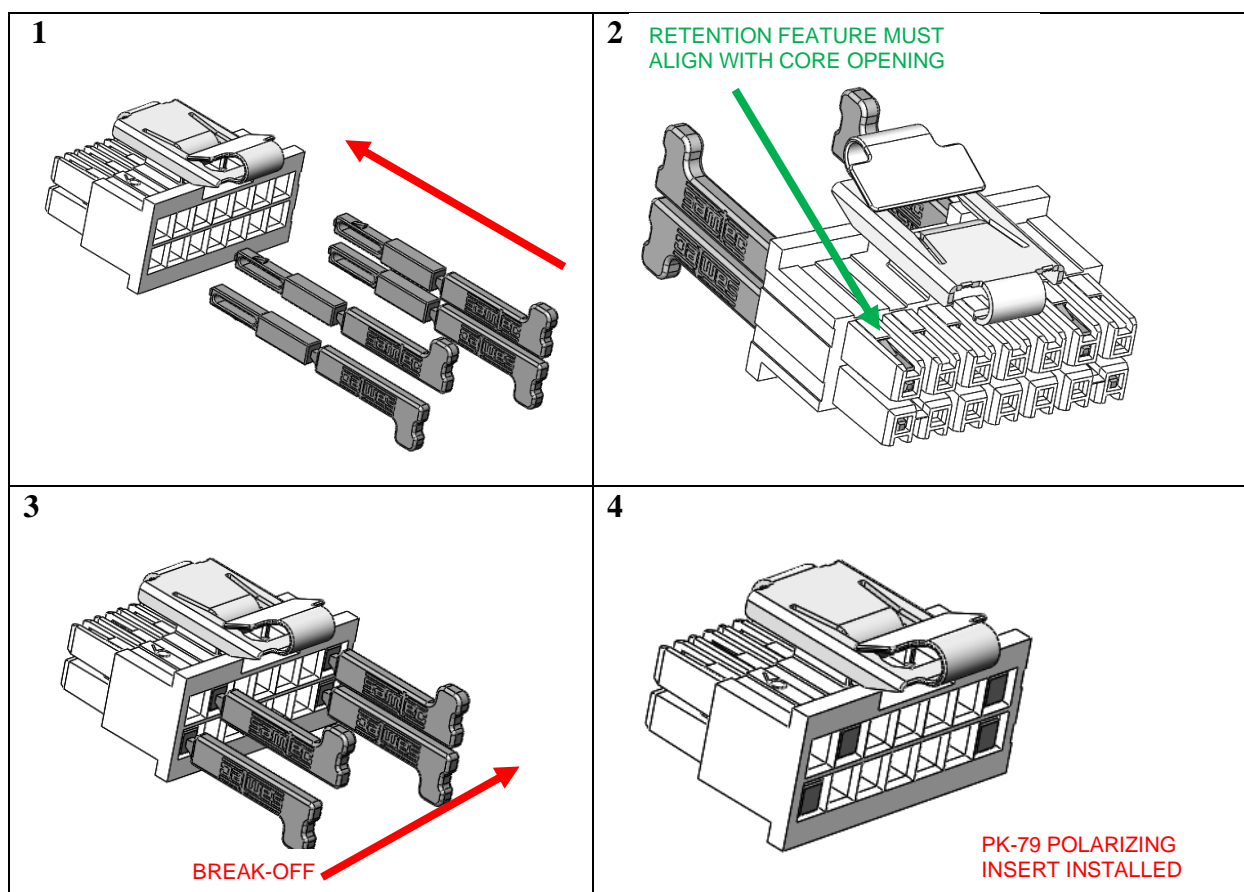

Series: .100" (2,54 mm) Mini Mate™ Double / Single Row Discrete Wire Cable Assembly, Socket / Terminal

7.4.2 PK-79 Polarizing IPD1-06-S

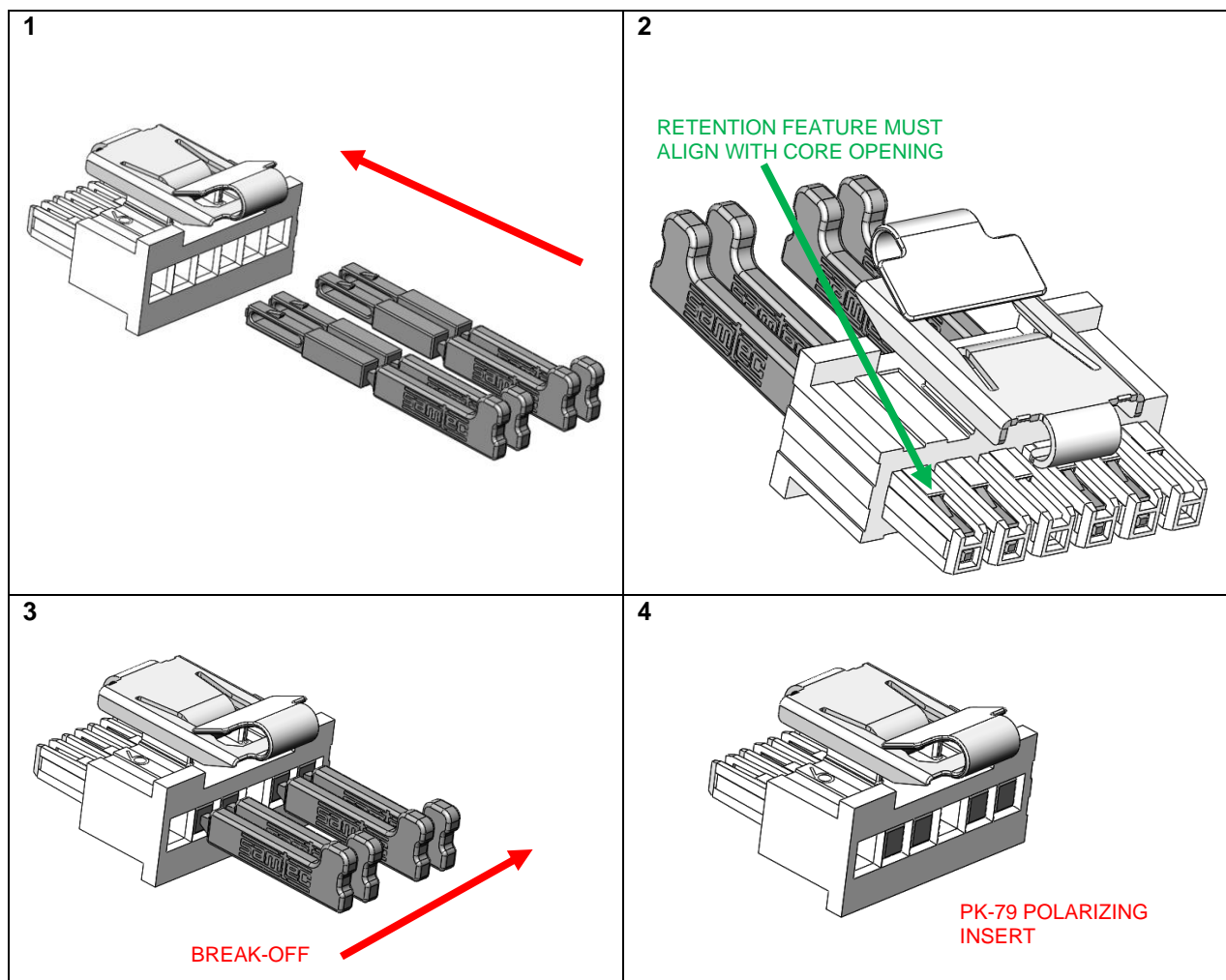

7.4.3 Installation instructions for PK-79 Insert

1. Align the PK-79 with the cores to be polarized
2. Use the Retention Feature Indicator Tab to align the retention feature with the core opening on the outside of the body. Retention feature must align with core opening for proper performance. Once aligned, insert the PK-79 until fully seated.
3. Break off PK-79 by bending remaining body along center axis of part
4. PK-79 fully installed

**Series:** .100" (2,54 mm) Mini Mate™ Double / Single Row Discrete Wire Cable Assembly, Socket / Terminal

## 8.0 ADDITIONAL RESOURCES

- 8.1 For general application and product assistance, contact our Rugged Product Group at [RUGGED@samtec.com](mailto:RUGGED@samtec.com)
- 8.2 For RoHS, REACH or other environmental compliance information, contact our Product Environmental Compliance Group at [PEC@samtec.com](mailto:PEC@samtec.com)
- 8.3 For additional mechanical testing or product information, contact our Customer Engineering Support at [CES@samtec.com](mailto:CES@samtec.com)
- 8.4 For any questions regarding tooling or assembly processes, contact our Tooling Group at [ATG@samtec.com](mailto:ATG@samtec.com)

### USE OF PRODUCT SPECIFICATION SHEET

This Product Specification Sheet (“PSS”) is a brief summary of information related to the Product identified. As a summary, it should only be used for the limited purpose of considering the purchase/use of Product. For specific, detailed information, including but not limited to testing and Product footprint, refer to Section 2.0 of this document and the links there provided to test reports and prints. This PSS is the property of Samtec, Inc. (“Samtec”) and contains proprietary information of Samtec, our various licensors, or both. Samtec does not grant express or implied rights or license under any patent, copyright, trademark or other proprietary rights and the use of the PSS for building, reverse engineering or replication is strictly prohibited. By using the PSS, the user agrees to not infringe, directly or indirectly, upon any intellectual property rights of Samtec and acknowledges that Samtec, our various licensors, or both own all intellectual property therein. The PSS is presented “AS IS”. While Samtec makes every effort to present excellent information, the PSS is only provided as a guideline and does not, therefore, warrant it is without error or defect or that the PSS contains all necessary and/or relevant information about the Product. The user agrees that all access and use of the PSS is at its own risk. **NO WARRANTIES EXPRESSED OR IMPLIED, INCLUDING ANY WARRANTY OF MERCHANTABILITY, FITNESS FOR A PARTICULAR PURPOSE OR OF ANY KIND WHATSOEVER ARE PROVIDED.**