

Series: **FQSFP-D8** 800G Flyover QSFP Double Density

FQSFP-D8 Cable Assembly

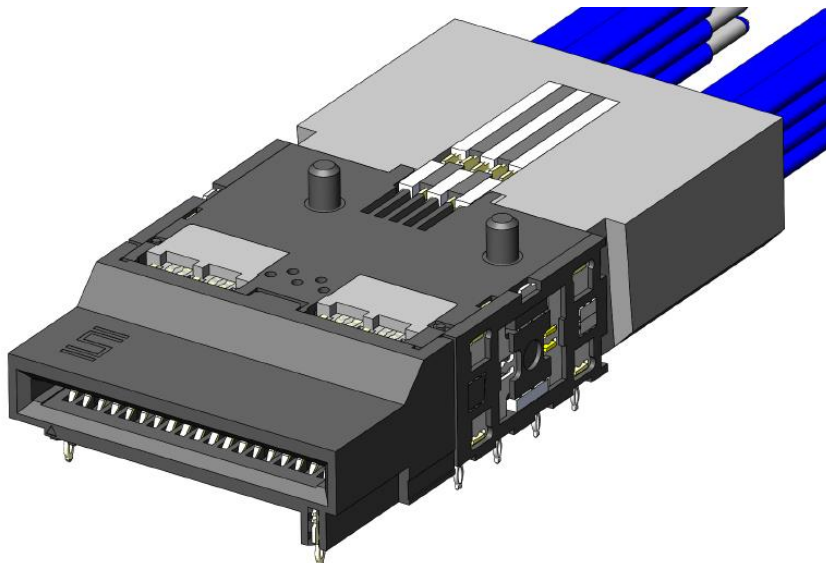

QSFP-D8 Cage

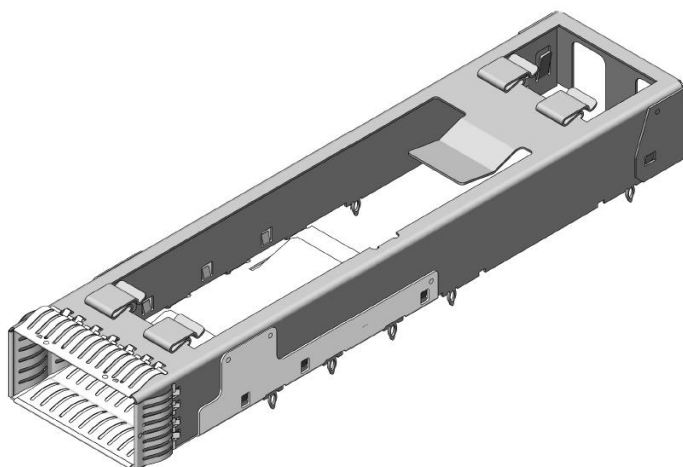

HS-QSFP-D8 Heat Sink

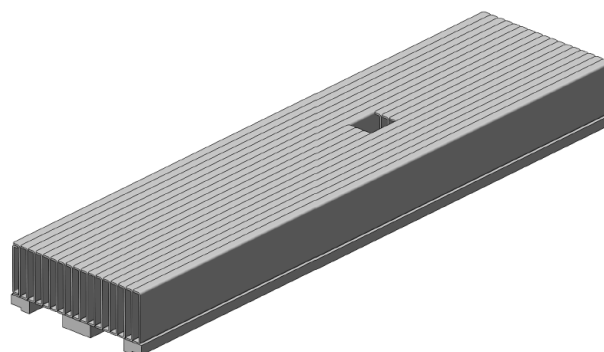

- **End2 Options Available:**
ARC6, ARP6, CPC, NVAC

See www.samtec.com for more information.

Series: FQSFP-D8 800G Flyover QSFP Double Density

1.0 SCOPE

1.1 This specification covers performance, testing and quality requirements for Samtec FQSFP Double Density 800G Flyover Cable System.

2.0 DETAILED INFORMATION

2.1 Product prints, footprints, catalog pages, test reports and other specific, detailed information can be found at FQSFP-D8 Cable Assembly: <https://www.samtec.com/products/fqsfp-d8>.

QSFP-D8 Cage: <https://www.samtec.com/products/qsfp-d8>

HS-QSFP-D8 Heat Sink <https://www.samtec.com/products/hs-qsfp-d8>

3.0 TESTING

3.1 **Current Rating:** 2.6A (4x1 Contacts Powered)

3.2 **Voltage Rating:** 155 VAC LS to LS, 140 VAC HS to HS, 140 VAC HS to GND, 100 VAC GND to Cage

3.3 **Operating Temperature Range:** -25 °C to 105 °C

3.4 **Operating Humidity Range:** 90% to 95% (Per EIA-364-31)

3.5 **Electrical:**

ITEM	TEST CONDITION	RESULT
Withstanding Voltage	EIA-364-20 (No Flashover, Sparkover, or Breakdown)	155 VAC LS to LS, 140 VAC HS to HS, 140 VAC HS to GND, 100 VAC GND to Cage
Insulation Resistance	EIA-364-21 (1000 MΩ minimum)	1,480 MΩ
Contact Resistance (LLCR)	EIA-364-23	Δ 15 mΩ maximum contact/ Δ 1 mΩ compliant pin (Samtec defined)/ No damage

3.6 **Mechanical:**

ITEM	TEST CONDITION	RESULT	STATUS
Durability	EIA-364-09C	100 cycles	PASS
Random Vibration	EIA-364-28 Condition V, Letter B 7.56 G 'RMS', 50 to 2000 Hz, 2 hours per axis, 3 axis total, PSD 0.04	Visual Inspection: No Damage LLCR: Δ 15 mΩ maximum contact/Δ 1 mΩ compliant pin Event Detection: No interruption > 50 Nanoseconds	PASS
Mechanical Shock	EIA-364-27 30 G, 6 milliseconds, sawtooth wave, 11.3 fps, 3 shocks/direction, 3 axes (18 total shocks)	Visual Inspection: No Damage LLCR: Δ 15 mΩ maximum contact/Δ 1 mΩ compliant pin Event Detection: No interruption > 50 Nanoseconds	PASS
Normal Force	EIA-364-04	30 grams minimum for Gold interface	PASS

Series: **FQSFP-D8** 800G Flyover QSFP Double Density

3.7 Environmental:

ITEM	TEST CONDITION	RESULT	STATUS
Thermal Shock	EIA-364-32 Thermal Cycles: 100 (30 minute dwell) Hot Temp: +85°C Cold Temp: -55°C Hot/Cold Transition: Immediate	Visual Inspection: No Damage LLCR: Δ 15 m Ω contact/ Δ 1 m Ω compliant pin DWV: 467 VAC LS to LS, 418 VAC HS to HS, 420 VAC HS to GND, 300 VAC GND to Cage IR: >1,480 M Ω	PASS
Thermal Aging (Temp Life)	EIA-364-17 Test Condition 4 @ 105°C Condition B for 250 hours	Visual Inspection: No Damage LLCR: 15 m Ω maximum increase DWV: 300 VAC Signal Ground to Chassis Ground 490 VAC High and Low Speed Signals IR: >1,500 M Ω	PASS
Cyclic Humidity	EIA-364-31 Test Temp: +25°C to +65°C Relative Humidity: 90 to 95% Test Duration: 240 hours	Visual Inspection: No Damage LLCR: Δ 15 m Ω contact/ Δ 1 m Ω compliant pin DWV: 467 VAC LS to LS, 418 VAC HS to HS, 420 VAC HS to GND, 300 VAC GND to Cage IR: >1,480 M Ω	PASS
Gas Tight	EIA-364-36 Gas Exposure: Nitric Acid Vapor Duration: 60 min. Drying Temp.: 50°C +/- 3°C Measurements: Within 1 hour of Exposure	LLCR: Δ 15 m Ω contact/ Δ 1 m Ω compliant pin	PASS

4.0 HIGH SPEED PERFORMANCE

4.1 Channel Simulation - Channel Performance Metric (CPM)



Note: CPM is a channel simulation based approach to understanding connector performance. For further information on CPM please visit [Introducing Channel Performance](#).

CPM is simulated using a Samtec specific channel. Connector performance may improve based on specific applications. Please email SIG Frontline SIGFrontline@samtec.com to determine performance in your system.

4.2 System Impedance: 92 Ohm for differential pair

Series: FQSFP-D8 800G Flyover QSFP Double Density

5.0 APPLICATION PROCEDURE

5.1 Connector Insertion Tooling

The FQSFP-D8 cable system shall be installed utilizing special insert tools for FQSFP-D8 end and the QSFP-D8 cage. If the FQSFP-D8 press-fit tails are longer than the thickness of the printed circuit board being installed into (longest press-fit tail length specification is $1.60 \pm 0.15\text{mm}$), a special bottom support tool will be necessary. This tool could be a PCB with oversized holes or a custom tool designed by the user.

5.2 PCB specifications

- PCB geometry and materials comply with appropriate connector footprint drawing.
- There is no maximum PCB thickness, but the footprint PTH dimensions must be held for the depth at which the compliant pin will be inserted.
- PCBs less than 1mm are not recommended for mechanical reasons. SI performance may also be affected by PCB thicknesses less than 1 mm.
- FQSFP-D8 connectors are only rated for one insertion. PTH's may be used for up to three insertions.

5.3 Board Insertion Procedure for FQSFP-D8 cable system

- **Application views**

Application view information can be found at link below:

<http://suddendocs.samtec.com/prints/fqsf-d8-xx-x-xx.x-x-mkt.pdf>

5.4 The post-application inspection should consist of several simple checks to ensure that the connector is applied properly and is not damaged.

- Visually assure that all press-fit tails are seated in the proper PCB holes and that none have been crushed during application.
- Visually check that the standoffs on the bottom of each assembly are seated flush and parallel with the PCB surface (see Figure 3 & 4). Once fully seated, there may be some minor gaps ($<0.1\text{ mm}$) due to component tolerances.

5.5 To prevent inadvertently lifting the cage from the board, the module should only be inserted after cage, heatsink, and panel are in place.

6.0 APPLICATION INFORMATION

6.1 Min Cable Bend Radius: TF-34100C-02-S-T-TB = .125" [3.175mm] for less than A 1 ohm drop.

6.2 Cable Management: Samtec recommends some form of cable management to prevent non-axial forces being applied to the connector.

Series: [FQSFP-D8](#) 800G Flyover QSFP Double Density

7.0 ADDITIONAL RESOURCES

- 7.1 For additional mechanical testing or product information, contact our FQSFP Group at FQSFP@samtec.com
- 7.2 For additional information on high speed performance testing, contact our Signal Integrity Group at SIG@samtec.com
- 7.3 For additional processing information, contact our Interconnect Processing Group at IPG@samtec.com.
- 7.4 For RoHS, REACH or other environmental compliance information, contact our Product Environmental Compliance Group at PEC@samtec.com

USE OF PRODUCT SPECIFICATION SHEET

This Product Specification Sheet (“PSS”) is a brief summary of information related to the Product identified. As a summary, it should only be used for the limited purpose of considering the purchase/use of Product. For specific, detailed information, including but not limited to testing and Product footprint, refer to Section 2.0 of this document and the links there provided to test reports and prints. This PSS is the property of Samtec, Inc. (“Samtec”) and contains proprietary information of Samtec, our various licensors, or both. Samtec does not grant express or implied rights or license under any patent, copyright, trademark or other proprietary rights and the use of the PSS for building, reverse engineering or replication is strictly prohibited. By using the PSS, the user agrees to not infringe, directly or indirectly, upon any intellectual property rights of Samtec and acknowledges that Samtec, our various licensors, or both own all intellectual property therein. The PSS is presented “AS IS”. While Samtec makes every effort to present excellent information, the PSS is only provided as a guideline and does not, therefore, warrant it is without error or defect or that the PSS contains all necessary and/or relevant information about the Product. The user agrees that all access and use of the PSS is at its own risk. **NO WARRANTIES EXPRESSED OR IMPLIED, INCLUDING ANY WARRANTY OF MERCHANTABILITY, FITNESS FOR A PARTICULAR PURPOSE OR OF ANY KIND WHATSOEVER ARE PROVIDED.**