

Series: **LPHS / LPHT** .050" (1,27 mm) EXTreme LPHPower™ Signal/Power Socket and Terminal Assembly

**LPHS Series** – Socket, Vertical Orientation

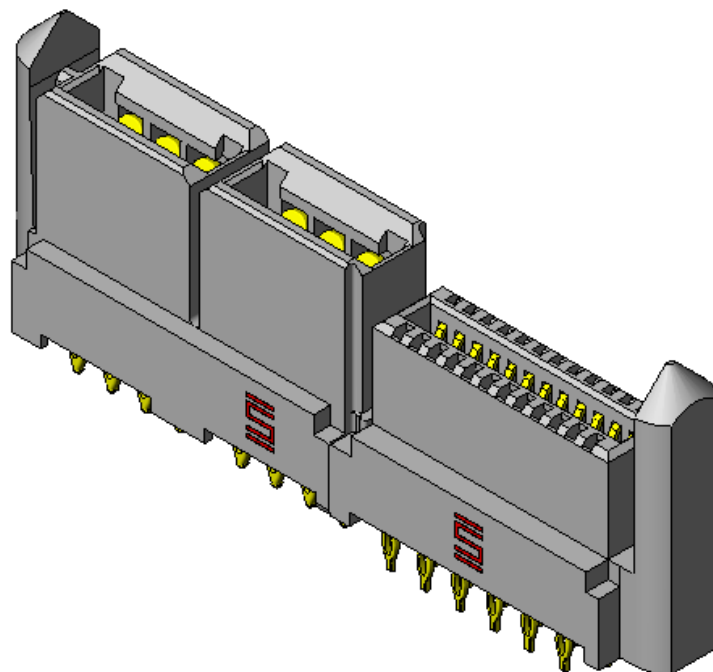

**LPHT Series** – Terminal, Right Angle Orientation

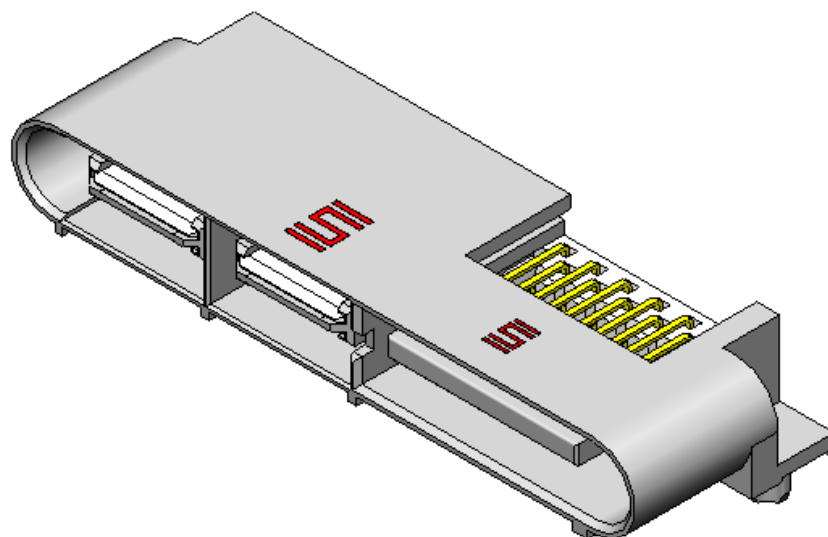

**Other configurations available for:**

- Right Angle Socket applications
- Mating card combinations

See [www.samtec.com](http://www.samtec.com) for more information.

**Series:** LPHS / LPHT .050" (1,27 mm) EXTreme LPHPower™ Signal/Power Socket and Terminal Assembly

## 1.0 SCOPE

**1.1** This specification covers performance, testing and quality requirements for Samtec LPHS / LPHT Series .050" (1,27 mm) EXTreme LPHPower™ 30 A per power blade Signal/Power Socket and Terminal Assembly. All information contained in this specification is for a Vertical socket / Right Angle terminal mated configuration unless otherwise noted. Right Angle socket / Right Angle terminal mated configuration is available on [www.samtec.com](http://www.samtec.com).

## 2.0 DETAILED INFORMATION

**2.1** Product prints, footprints, catalog pages, test reports and other specific, detailed information can be found at <http://www.samtec.com/?LPHS> and <http://www.samtec.com/?LPHT>.

## 3.0 TESTING

**3.1 Current Rating:** Power: 33A / Signal: 2.5A (One Pin Powered Per Row)

**3.2 Voltage Rating:** 220 VAC (Signal)

**3.3 Operating Temperature Range:** -55°C to +125°C

**3.4 Electrical:**

ITEM	TEST CONDITION	REQUIREMENT	STATUS
Withstanding Voltage	EIA-364-20 (No Flashover, Sparkover, or Breakdown)	655 VAC	Pass
Insulation Resistance	EIA-364-21 (1000 MΩ minimum)	5,000 MΩ	Pass
Contact Resistance (LLCR)	EIA-364-23	Δ 15 mΩ maximum (Samtec defined)/ No damage	Pass

**3.5 Mechanical:**

ITEM	TEST CONDITION	REQUIREMENT	STATUS
Durability	EIA-364-09C	100 cycles	Pass
Random Vibration	EIA-364-28 Condition V, Letter B 7.56 G 'RMS', 50 to 2000 Hz, 2 hours per axis, 3 axis total, PSD 0.04	Visual Inspection: No Damage LLCR: Δ 15 mΩ maximum Event Detection: No interruption > 50 Nanoseconds	Pass
Mechanical Shock	EIA-364-27 100 G, 6 milliseconds, sawtooth wave, 11.3 fps, 3 shocks/direction, 3 axis (18 total shocks)	Visual Inspection: No Damage LLCR: Δ 15 mΩ maximum Event Detection: No interruption > 50 Nanoseconds	Pass
Normal Force	EIA-364-04	30 grams minimum for Gold interface	Pass

Series: **LPHS / LPHT** .050" (1,27 mm) EXTreme LPHPower™ Signal/Power Socket and Terminal Assembly

**3.6 Environmental:**

ITEM	TEST CONDITION	REQUIREMENT	STATUS
Thermal Shock	EIA-364-32 Thermal Cycles: 100 (30 minute dwell) Hot Temp: 85°C Cold Temp: -55°C Hot/Cold Transition: Immediate	Visual Inspection: No Damage LLCR: $\Delta$ 15 m $\Omega$ DWV: 655 VAC IR: >5,000 M $\Omega$	Pass
Thermal Aging (Temp Life)	EIA-364-17 Test Condition 4 @ 105°C Condition B for 250 hours	Visual Inspection: No Damage LLCR: $\Delta$ 15 m $\Omega$ DWV: 390 VAC IR: >5,000 M $\Omega$	Pass
Cyclic Humidity	EIA-364-31 Test Temp: 25°C to 65°C Relative Humidity: 90 to 95% Test Duration: 240 hours	Visual Inspection: No Damage LLCR: $\Delta$ 15 m $\Omega$ DWV: 655 VAC IR: >5,000 M $\Omega$	Pass
Gas Tight	EIA-364-36 Gas Exposure: Nitric Acid Vapor Duration: 60 min. Drying Temp.: 50°C +/- 3°C Measurements: Within 1 hour of Exposure	LLCR: $\Delta$ 15 m $\Omega$	Pass

**4.0 MATED SYSTEM**

Mated view information can be found at link below:

<http://www.samtec.com/documents/webfiles/cpdf/LPHX%20Mated%20Document-MKT.pdf>

**5.0 CREEPAGE AND CLEARANCE DISTANCES**

	Clearance	Creepage
LPHS-VT	2.69mm (.106")	2.86mm (.113")
LPHS-RA	1.36mm (.054")	5.63mm (.222")
LPHT-RA	1.36mm (.054")	1.21mm (.048")

Series: LPHS / LPHT .050" (1,27 mm) EXTreme LPHPower™ Signal/Power Socket and Terminal Assembly

### 6.0 POLARIZING FEATURES

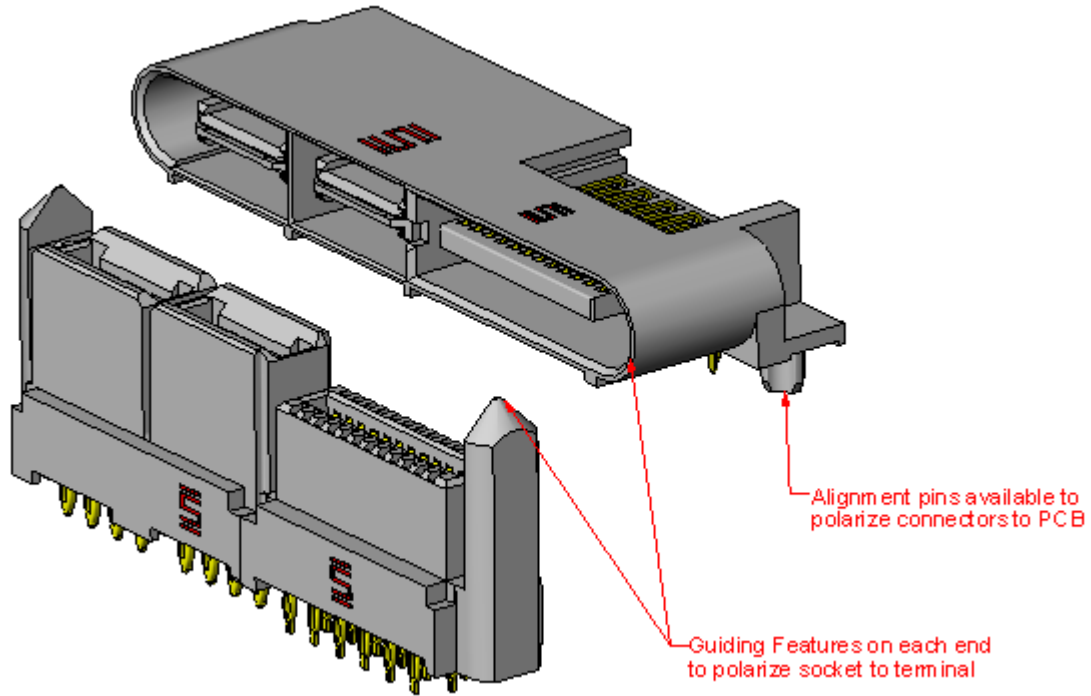

### 7.0 PROCESSING RECOMMENDATIONS

#### 7.1 Mating Alignment Requirements:

7.1.1 Maximum guidance/capture in applications where at least one half of the interface is free to float.

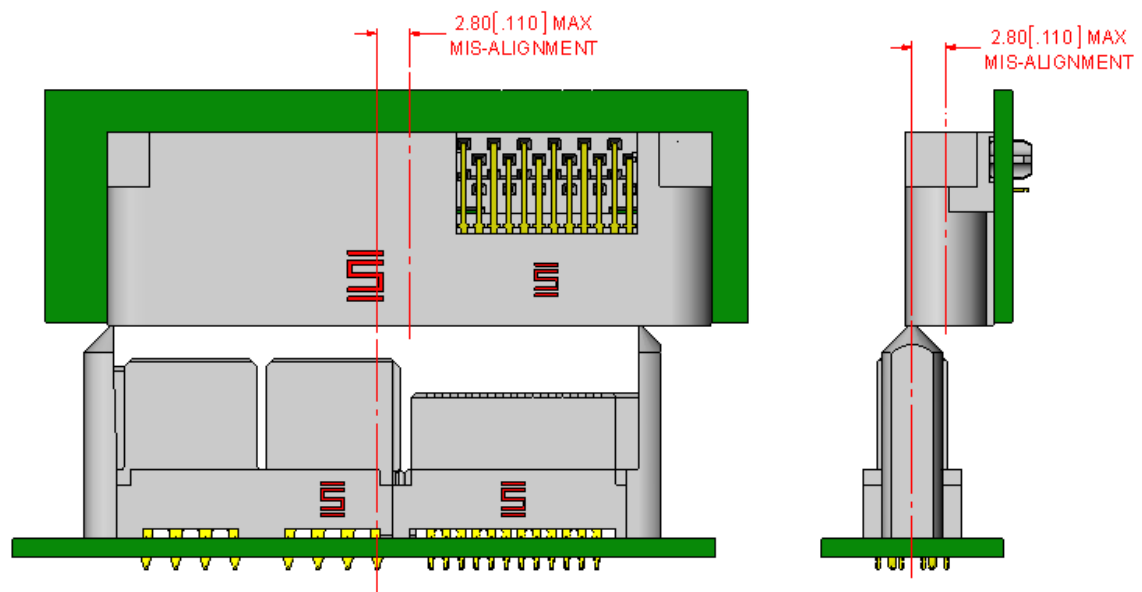

Series: LPHS / LPHT .050" (1,27 mm) EXTreme LPHPower™ Signal/Power Socket and Terminal Assembly

7.1.2 The parts can be rigidly misaligned by no more than .003" (0,08 mm) in the X- and .003" (0,08 mm) in the Y-direction to ensure a good mate.

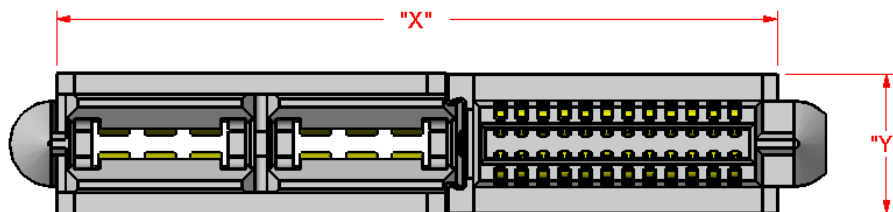

7.2 Mating Angle Requirements: For LPHS mated with LPHT, Connectors to be mated and unmated axially only, zippering angles may damage connector and/or solder joints; for LPHS mated with card, the connector can be zippered 2° in either the longitudinal or lateral directions.

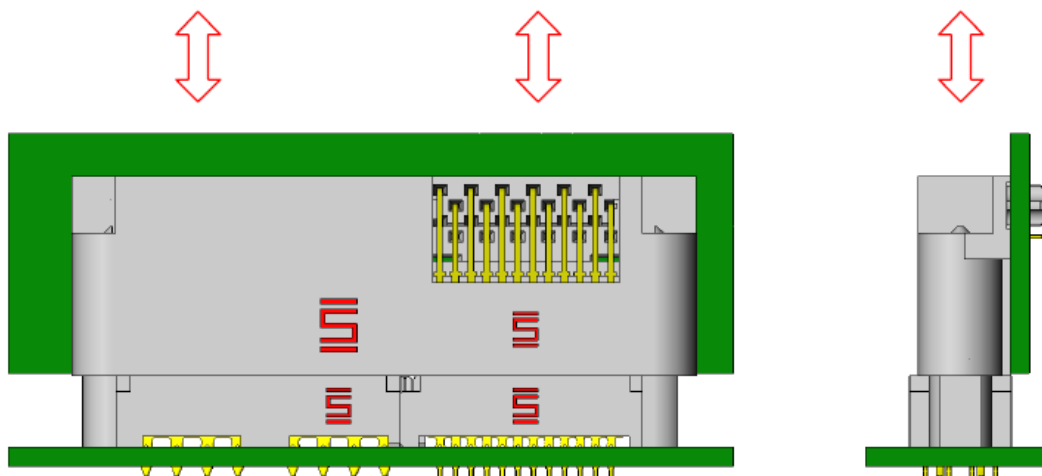

7.2.1

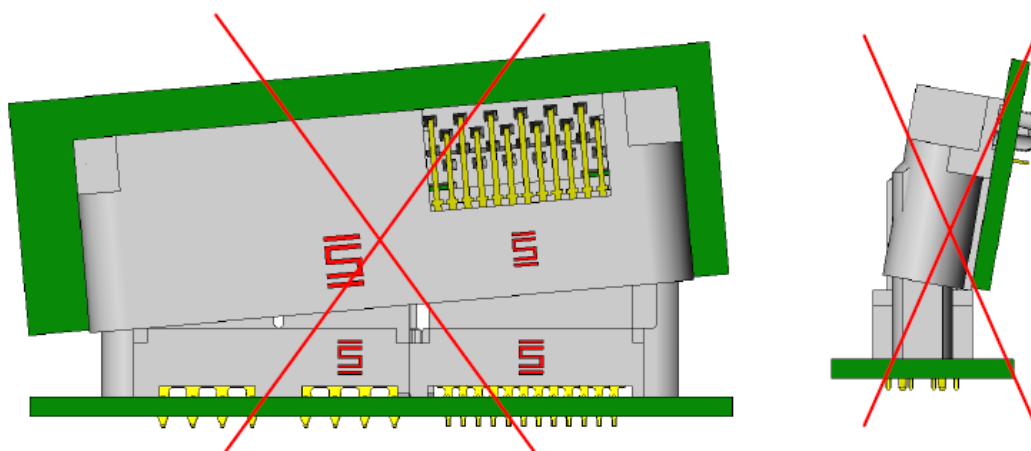

7.2.2

Series: LPHS / LPHT .050" (1,27 mm) EXTreme LPHPower™ Signal/Power Socket and Terminal Assembly

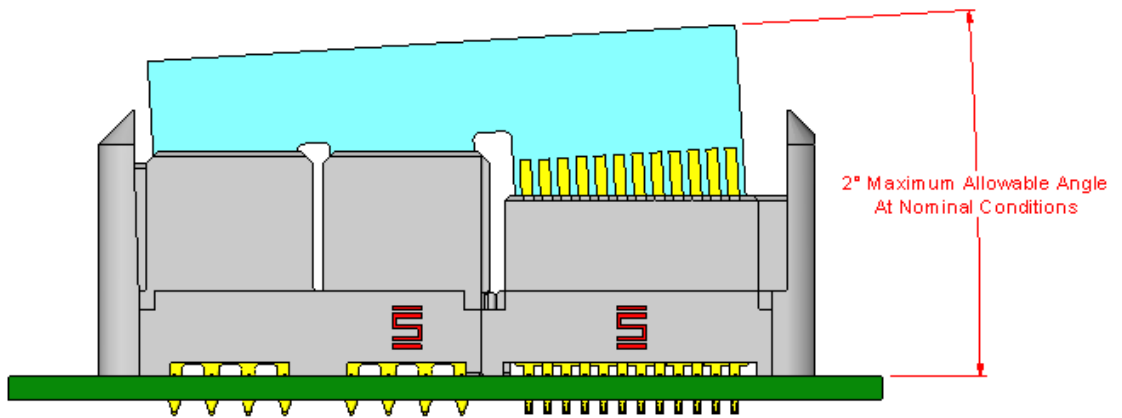

7.2.3

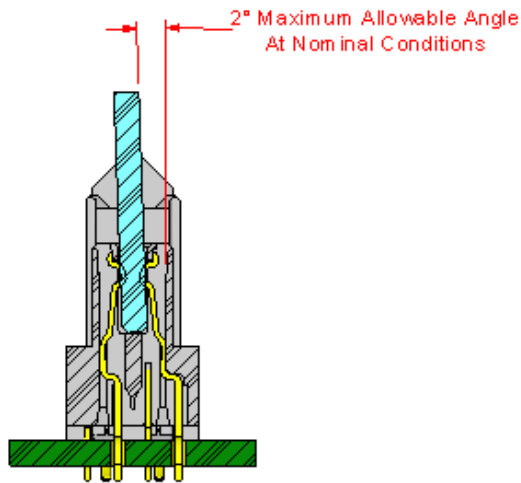

7.2.4

7.3 Press Fit Tooling Application:

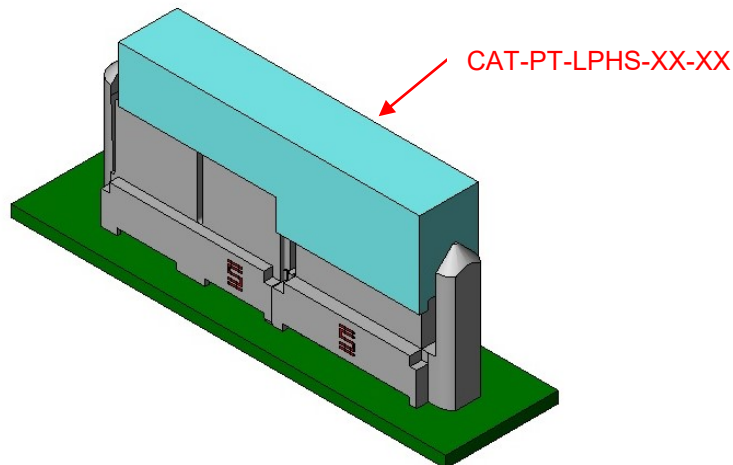

Series: **LPHS / LPHT** .050" (1,27 mm) EXTreme LPHPower™ Signal/Power Socket and Terminal Assembly

#### 7.4 Press Fit Tool Description

The following are Samtec Press Fit tool part numbers, the "XX" in the table should follow the specific signal positions.

Press Fit Tools	
	PART NUMBER
Power Positions	LPHS Series
-02	CAT-PT-LPHS-02-XX
-04	CAT-PT-LPHS-04-XX
-06	CAT-PT-LPHS-06-XX
-08	CAT-PT-LPHS-08-XX
-10	CAT-PT-LPHS-10-XX

#### 7.5 Termination Requirements and Inspection

- A. There will be no bucking of the pins under the connector.
- B. There will be no excessive movement of contact.
- C. The connector will be flush to .005" above PCB and the Pins will be the appropriate depth into the PCB.
- D. None of the plated mating surface have been scratched.

#### 8.0 ADDITIONAL RESOURCES

- 8.1 For additional mechanical testing or product information, contact our Customer Engineering Support Group at [CES@samtec.com](mailto:CES@samtec.com)
- 8.2 For additional information on high speed performance testing, contact our Signal Integrity Group at [SIG@samtec.com](mailto:SIG@samtec.com)
- 8.3 For additional processing information, contact our Interconnect Processing Group at [IPG@samtec.com](mailto:IPG@samtec.com).
- 8.4 For RoHS, REACH or other environmental compliance information, contact our Product Environmental Compliance Group at [PEC@samtec.com](mailto:PEC@samtec.com)

#### USE OF PRODUCT SPECIFICATION SHEET

This Product Specification Sheet ("PSS") is a brief summary of information related to the Product identified. As a summary, it should only be used for the limited purpose of considering the purchase/use of Product. For specific, detailed information, including but not limited to testing and Product footprint, refer to Section 2.0 of this document and the links there provided to test reports and prints. This PSS is the property of Samtec, Inc. ("Samtec") and contains proprietary information of Samtec, our various licensors, or both. Samtec does not grant express or implied rights or license under any patent, copyright, trademark or other proprietary rights and the use of the PSS for building, reverse engineering or replication is strictly prohibited. By using the PSS, the user agrees to not infringe, directly or indirectly, upon any intellectual property rights of Samtec and acknowledges that Samtec, our various licensors, or both own all intellectual property therein. The PSS is presented "AS IS". While Samtec makes every effort to present excellent information, the PSS is only provided as a guideline and does not, therefore, warrant it is without error or defect or that the PSS contains all necessary and/or relevant information about the Product. The user agrees that all access and use of the PSS is at its own risk. **NO WARRANTIES EXPRESSED OR IMPLIED, INCLUDING ANY WARRANTY OF MERCHANTABILITY, FITNESS FOR A PARTICULAR PURPOSE OR OF ANY KIND WHATSOEVER ARE PROVIDED.**

\* EXTreme LPHPower™ is a trademark of Molex Incorporated.