

Series: **MCX** 50Ω Mini MCX Jack / Plug

MCX – Jack, Straight Orientation, Through-hole

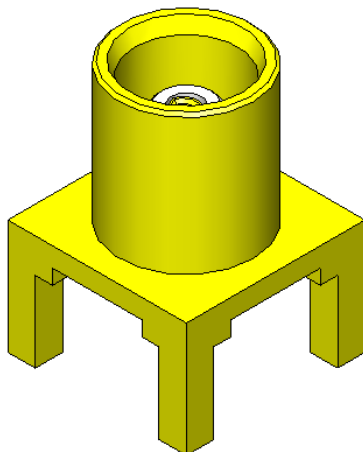

MCX – Plug, Straight Orientation, Through-hole

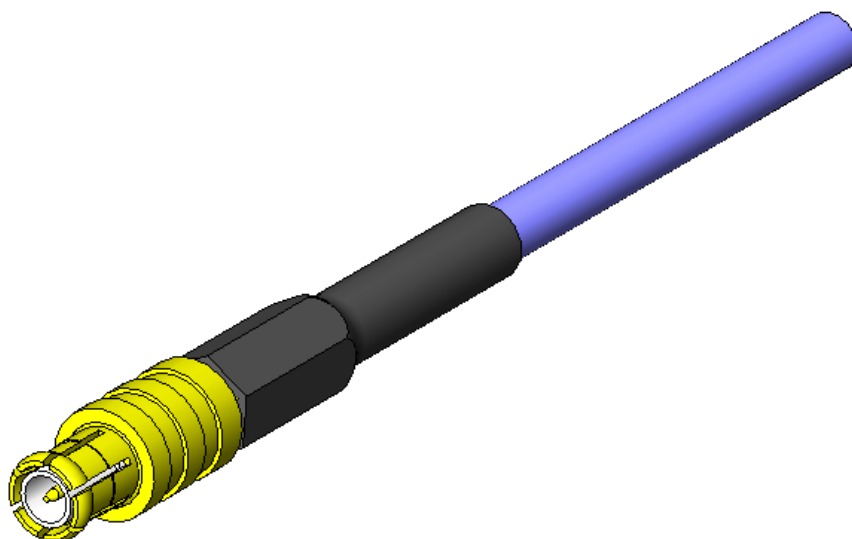

Other configurations available for:

Vertical and right angle cable-to-board applications

Through-hole, surface mount, edge mount, panel mount and mixed technology

Termination to various cable types

See www.samtec.com for more information.

Series: **MCX** 50Ω Mini MCX Jack / Plug

1.0 SCOPE

1.1 This specification covers performance, testing and quality requirements for Samtec MCX Series. These connectors are available in vertical, edge mount and right angle. All information contained in this specification is for a straight jack board connector to a straight plug cable assembly unless otherwise noted.

2.0 DETAILED INFORMATION

2.1 Product prints, footprints, catalog pages, test reports and other specific, detailed information can be found at <http://www.samtec.com/rf/50-ohm/mcx.aspx>.

3.0 TESTING

3.1

ITEM	RF174		RF316		RF178	
Terminal Orientation	ST	RA	ST	RA	ST	RA
Withstanding Voltage	630 DCV	1000 DCV	630 DCV	1000 DCV	630 DCV	1000 DCV

3.2 Electrical:

ITEM	TEST CONDITION	REQUIREMENT	STATUS
Withstanding Voltage	EIA-364-20 (No Flashover, Sparkover, or Breakdown)	See Section 3.1	Pass
Insulation Resistance	EIA-364-21 (5000 MΩ minimum)	15,000 MΩ	Pass
Contact Resistance (LLCR)	EIA-364-23	Δ 15 mΩ maximum (Samtec defined)/ No damage	Pass

3.3 Mechanical:

ITEM	TEST CONDITION	REQUIREMENT	STATUS
Durability	EIA-364-09C	100 cycles (w/Env.) 1000 cycles (w/o Env)	Pass
Random Vibration	EIA-364-28 Condition V, Letter B 7.56 G 'RMS', 50 to 2000 Hz, 2 hours per axis, 3 axis total, PSD 0.04	Visual Inspection: No Damage LLCR: Δ 15 mΩ maximum Event Detection: No interruption > 1.0 microsecond	Pass
Mechanical Shock	EIA-364-27 100 G, 6 milliseconds, half sine, 12.3 ft/s, 3 shocks/direction, 3 axis (18 total shocks)	Visual Inspection: No Damage LLCR: Δ 15 mΩ maximum Event Detection: No interruption > 1.0 microsecond	Pass
Normal Force	EIA-364-04	30 grams minimum for gold interface	Pass
Mating / Unmating Force	EIA-364-13	Mating force: 14.2 lbs (63 N) maximum Unmating force: 1.8 lbs (8 N) ~ 4.5 lbs (20 N)	Pass

Series: MCX 50Ω Mini MCX Jack / Plug

3.4 Environmental:

ITEM	TEST CONDITION	REQUIREMENT	STATUS
Thermal Shock	EIA-364-32 Thermal Cycles: 100 (30 minute dwell) Hot Temp: 85°C Cold Temp: -55°C Hot/Cold Transition: Immediate	Visual Inspection: No Damage LLCR: Δ 15 m Ω DWV: 825 VAC IR: >15,000 M Ω	Pass
Thermal Aging (Temp Life)	EIA-364-17 Test Condition 4 @ 105°C Condition B for 250 hours	Visual Inspection: No Damage LLCR: Δ 15 m Ω	Pass
Cyclic Humidity	EIA-364-31 Test Temp: 25°C to 65°C Relative Humidity: 90 to 95% Test Duration: 240 hours	Visual Inspection: No Damage LLCR: Δ 15 m Ω DWV: 825 VAC IR: >15,000 M Ω	Pass
Gas Tight	EIA-364-36 Gas Exposure: Nitric Acid Vapor Duration: 60 min. Drying Temp.: 50°C +/- 3°C Measurements: Within 1 hour of Exposure	LLCR: Δ 15 m Ω	Pass

4.0 MATED SYSTEM

4.1 Orientations

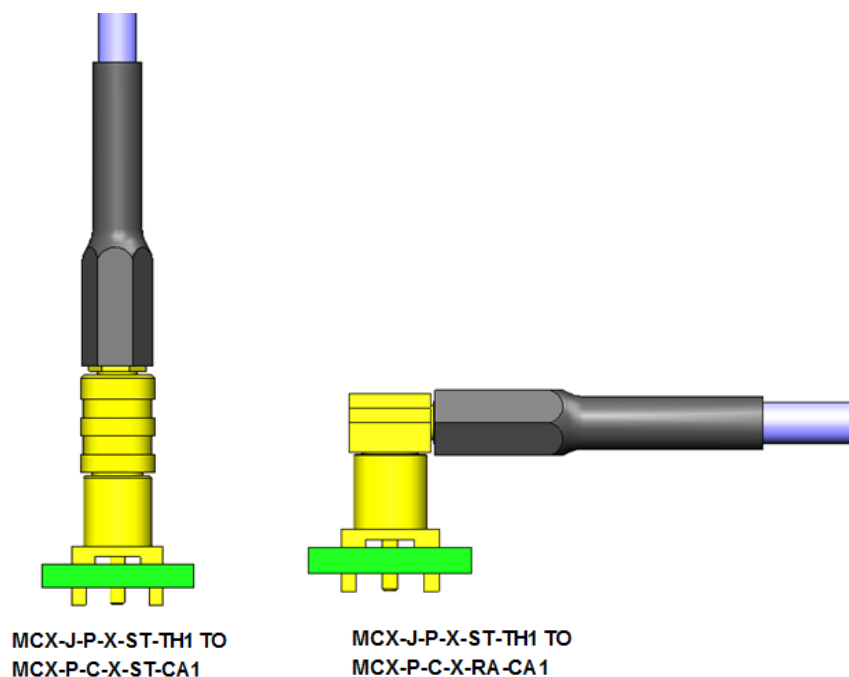

Series: MCX 50Ω Mini MCX Jack / Plug

5.0 HIGH SPEED PERFORMANCE

5.1 Frequency Range:

Cable type	RF174		RF316		RF178	
MCX Orientation	RA	ST	RA	ST	RA	ST
Frequency Range	DC-6 GHz	DC-6 GHz	DC-6 GHz	DC-6 GHz	DC-6 GHz	DC-6 GHz

5.2 Impedance: 50 ohm

5.3 Rating: Performance up to 6 GHz

6.0 PROCESSING RECOMMENDATIONS

6.1 Maximum Reflow Passes: Versions of these connectors with surface mount features can withstand three reflow passes at a maximum component temperature of 260°C.

6.2 Stencil Thickness: The recommended stencil thickness is .006" (0.15 mm).

6.3 Reflow Environment: Samtec recommends the use of a low level oxygen environment (typically achieved through Nitrogen gas infusion) in the reflow process to improve solderability.

6.4 Cleaning: Samtec, Inc. has verified that our connectors may be cleaned in accordance with the solvents and conditions designated in the EIA-364-11A standard.

Series: **MCX** 50Ω Mini MCX Jack / Plug

6.5 Due to variances in equipment, solder pastes and applications (board design, component density, etc.), Samtec does not specify a recommended reflow profile for our connectors. The processing parameters provided by the solder paste manufacturer should be employed and can usually be found on their website.

All of Samtec's surface mount components are lead free reflow compatible and compliant with the profile parameters detailed in IPC/JEDEC J-STD-020 which requires that components be capable of withstanding a peak temperature of 260°C as well as 30 seconds above 255°C.

Samtec Recommended Temperature Profile Ranges (SMT)

Sn-Pb Eutectic Assembly

Preheat/Soak (100°C-150°C)	Max Ramp Up Rate	Reflow Time (above 183°C)	Peak Temp	Time within 5°C of 235°C	Max Ramp Down Rate	Time 25°C to Peak Temp
60-120 sec.	3°C/s max.	40-150 sec.	235°C	20 sec. max.	6°C/s max.	6 min. max.

Pb-Free Assembly

Preheat/Soak (150°C-200°C)	Max Ramp Up Rate	Reflow Time (above 217°C)	Peak Temp	Time within 5°C of 260°C	Max Ramp Down Rate	Time 25°C to Peak Temp
60-120 sec.	3°C/s max.	40-150 sec.	260°C	30 sec. max.	6°C/s max.	8 min. max.

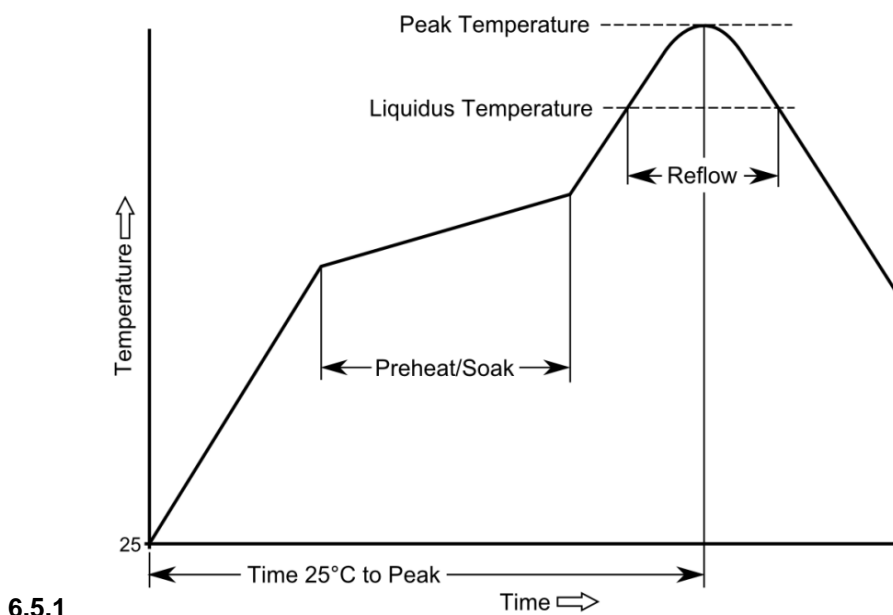

These guidelines should not be considered design requirements for all applications. Samtec recommends testing interconnects on your boards in your process to guarantee optimum results.

Series: **MCX** 50Ω Mini MCX Jack / Plug

7.0 APPLICATION INFORMATION

7.1 Minimum Cable Bend Radius: RF174 = 1.00 in [25.4]
RF316 = .50 in [12.7]
RF178 = .40 in [10.2]

7.2 Contact Captivation: Axial force 2.25 lbs (10 N)

8.0 ADDITIONAL RESOURCES

- 8.1** For additional mechanical testing or product information, contact our Customer Engineering Support Group at CES@samtec.com
- 8.2** For additional information on high speed performance testing, contact our Signal Integrity Group at SIG@samtec.com
- 8.3** For additional processing information, contact our Interconnect Processing Group at IPG@samtec.com
- 8.4** For RoHS, REACH or other environmental compliance information, contact our Product Environmental Compliance Group at PEC@samtec.com

USE OF PRODUCT SPECIFICATION SHEET

This Product Specification Sheet (“PSS”) is a brief summary of information related to the Product identified. As a summary, it should only be used for the limited purpose of considering the purchase/use of Product. For specific, detailed information, including but not limited to testing and Product footprint, refer to Section 2.0 of this document and the links there provided to test reports and prints. This PSS is the property of Samtec, Inc. (“Samtec”) and contains proprietary information of Samtec, our various licensors, or both. Samtec does not grant express or implied rights or license under any patent, copyright, trademark or other proprietary rights and the use of the PSS for building, reverse engineering or replication is strictly prohibited. By using the PSS, the user agrees to not infringe, directly or indirectly, upon any intellectual property rights of Samtec and acknowledges that Samtec, our various licensors, or both own all intellectual property therein. The PSS is presented “AS IS”. While Samtec makes every effort to present excellent information, the PSS is only provided as a guideline and does not, therefore, warrant it is without error or defect or that the PSS contains all necessary and/or relevant information about the Product. The user agrees that all access and use of the PSS is at its own risk. **NO WARRANTIES EXPRESSED OR IMPLIED, INCLUDING ANY WARRANTY OF MERCHANTABILITY, FITNESS FOR A PARTICULAR PURPOSE OR OF ANY KIND WHATSOEVER ARE PROVIDED.**