

1. INTRODUCTION

This instruction sheet covers the use of the SAMTEC XCede HD Stiffener Rework Tool CAT-RE-HDTF-X. This tool assists in the removal and insertion of the metal stiffener on the HDTF-RA connector. This tool can be used on individual modules as well as BSP modules.

2. CUSTOMER SERVICE

Further tooling and product application assistance is available by contacting the **Samtec Application Service Line +1-800-726-8329 (+1-812-944-6733)** 8:00 AM to 5:00 PM EST. To expedite your inquiry, have the pertinent part numbers for the product and tooling.

3. DESCRIPTION

Each tool has the side marked with the tooling number. Make sure it matches the tooling number specified in this document.

4. REMOVAL

The following steps are recommended for removing the HDTF-RA stiffener:

1. Prior to removing the stiffener, verify the stiffener removal tool (**Figure 1**) is in proper working order and condition. Ensure all stiffener engagement pins are present and protruding at least 0.030" from each opposing face of the pin block, as seen in **Figure 2**. If any pins are missing, bent, or broken, remove and replace them.
2. Ensure that the stiffener removal tool is in the fully-closed position (tighten handle clockwise until hard stop).
3. Orient the tool above the connector, so that the pins are facing towards the connector, and the tool's plastic insert is facing up. The tool's handle should be pointed in the direction of the connector mating surface shown in **Figure 3**.

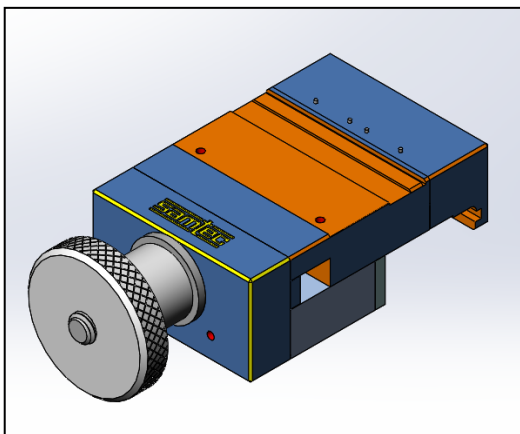

FIGURE 1

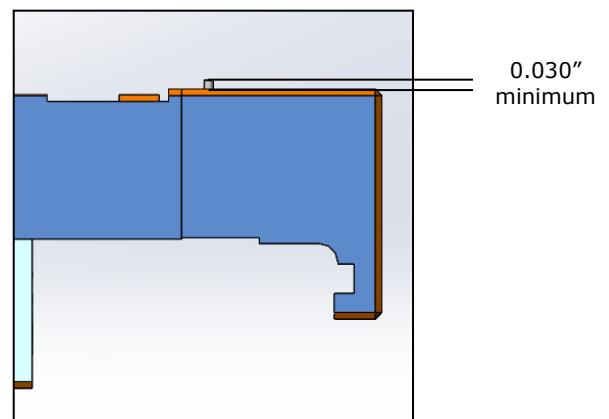

FIGURE 2

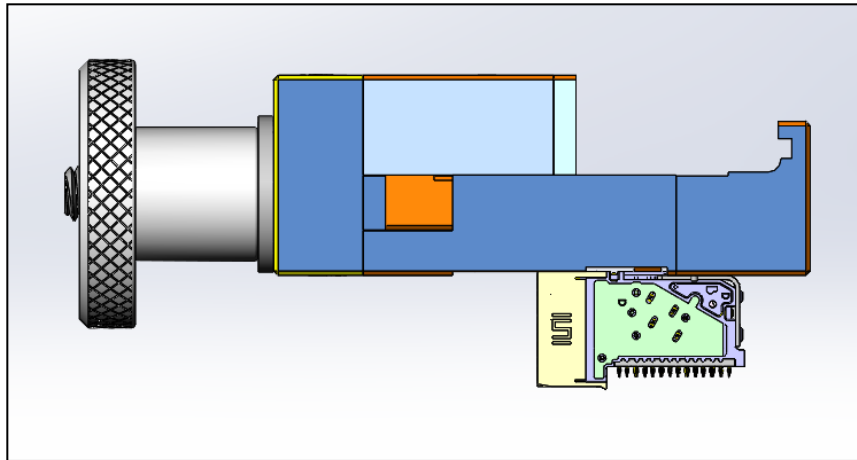

FIGURE 3

4. Align the tool at one end of the connector, so that the pins are engaged with the holes in the metal stiffener.
5. While applying enough downward pressure to ensure that the stiffener tool pins stay engaged into the metal stiffener holes, begin turning the knob counterclockwise until a force is felt, and the metal stiffener should start to separate from the connector modules as shown in **Figure 4**. Continue to turn knob for one full rotation and the metal stiffener should begin to further disengage from the connector plastic. If the connector is under 2.0" in length, continue to turn the knob counterclockwise (~2 full turns total) until the stiffener has completely separated from the connector plastic and continue to Step 7. If the connector is longer than 2.0" in length continue to Step 6.

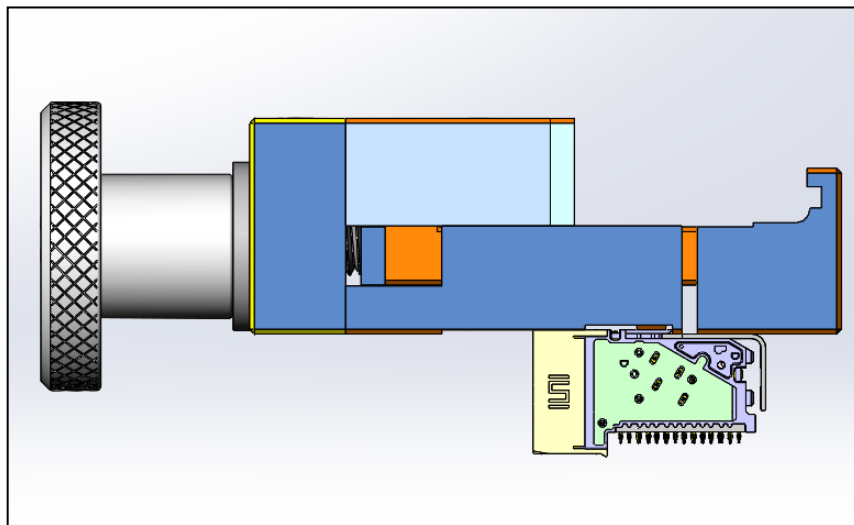

FIGURE 4

6. Turn the knob in the clockwise direction, returning the tool to its original "closed" position. Lift the tool off the connector and reengage the tool ~1.0 – 2.0 inches further down the length of the connector. Repeat Steps 5 and 6, working back-and-forth across the length of the connector, carefully "walking" the metal stiffener off the connector plastic.
7. Remove the stiffener from the connector assembly, and set aside.

5. INSERTION

The following steps are recommended for inserting a HDTF-RA stiffener:

1. Place the stiffener onto the connector, and align the stiffener slots with plastic tabs on the wafers (**Figure 5**), ensuring stiffener is not overhanging the plastic on either side.

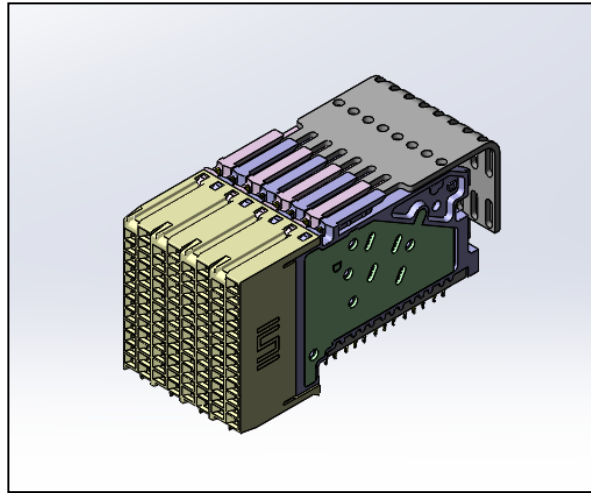

FIGURE 5

2. The same tool used for removing the stiffener is also used for reinstalling the stiffener.
3. Verify that the stiffener tool is in the full open position by turning the knob counterclockwise until a hard stop is achieved.
4. Orient the stiffener tool above the connector so that the connector will be inside of the open jaws, with the knob facing towards the mating side of the connector as seen in **Figure 6**.

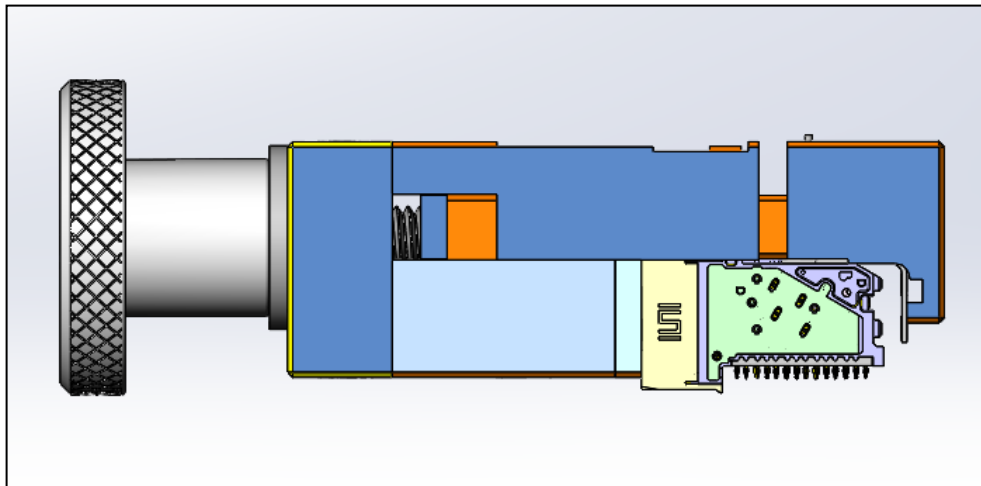

FIGURE 6

5. Place the open tool onto the connector, and while applying a small amount of downward force onto the connector, turn the knob clockwise until the top of the plastic stiffener tabs are even with the metal stiffener. Verify that the plastic stiffener tabs are aligned with the slots in the metal stiffener, and then continue to turn the knob clockwise until the stiffener is fully seated (bottomed) onto the connector body, shown in **Figure 7**.

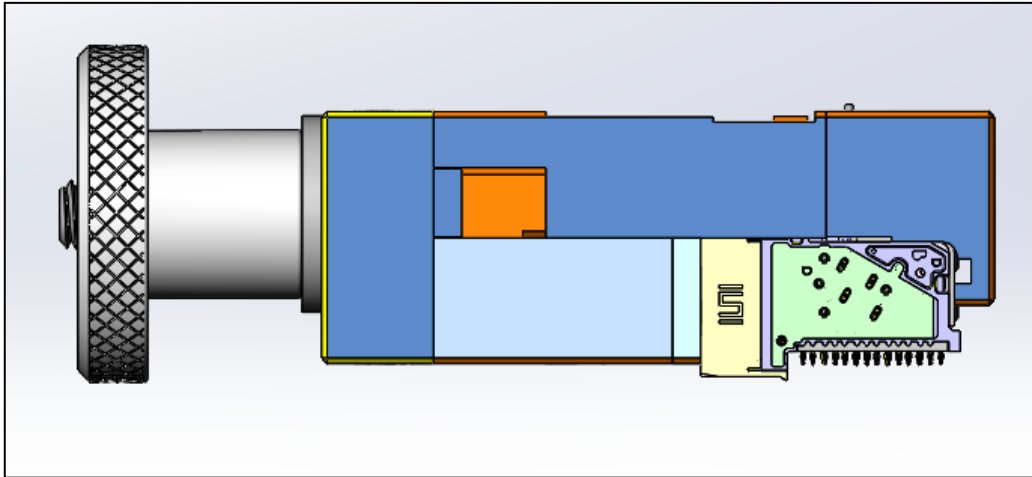

FIGURE 7

6. Turn the knob counterclockwise to open the tool and remove it from the connector.
7. If the connector is longer than 2.0", repeat Steps 4 thru 6 down the length of the connector until the entire stiffener is fully seated. Verify that the plastic stiffener tabs are protruding thru the metal stiffener slots down the entire length of the connector.

NOTE: Use caution when reworking connectors with power connectors. The daughtercard power connectors extend beyond the mating face of the signal wafers, and as a result are more likely to be overstressed without proper technique. When re-installing the stiffener and using powers for support, be sure the tools is centered across the points of contact, and the tool is not over tightened.

When working with powers, the best method of reinstallation depending on your specific connector configuration is to:

- A. Push the stiffener onto the connector as far as possible by hand.
- B. Work the tool down the entire length of the connector applying only enough force to pre-seat the stiffener.
- C. Completely sea the stiffener in the signal wafer areas only (not closing the stiffener tool into the power modules at all).
- D. Completely seat the stiffener onto the power connectors by returning the tool to the areas with power, and applying a minimum amount of force.

Replace any end caps and guide modules without posts, and inspect entire connector looking for unseated wafers onto the PCB, unseated wafers into the stiffener, damages wafer hats, etc.