

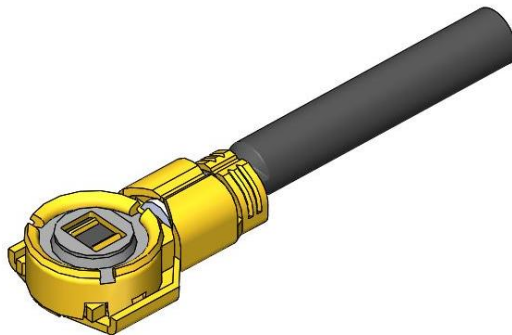

Project Number: Design Qualification Test Report	Tracking Code: 1770694_Report_Rev_2
Requested by: Alvin Wang	Date: 1/28/2019
Part #: RSP-122811-03/MH081-MH4RP-505050-0190	Tech: Peter Chen
Part description: RSP/MH081	Qty to test: 40
Test Start: 10/25/2018	Test Completed: 11/12/2018

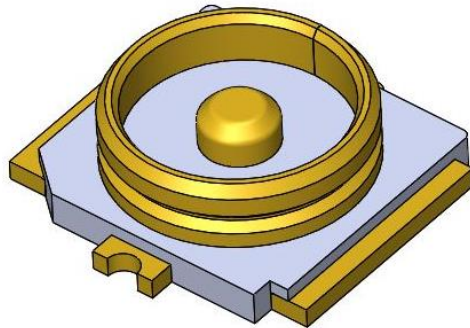

**DESIGN QUALIFICATION TEST REPORT**

**RSP/MH081**

**RSP-122811-03/MH081-MH4RP-505050-0190**

**REVISION HISTORY**

<b>DATA</b>	<b>REV.NUM.</b>	<b>DESCRIPTION</b>	<b>ENG</b>
<b>12/25/2018</b>	<b>1</b>	<b>Initial Issue</b>	<b>PC</b>
<b>1/25/2019</b>	<b>2</b>	<b>Updated the part number</b>	<b>PC</b>

## CERTIFICATION

All instruments and measuring equipment were calibrated to National Institute for Standards and Technology (NIST) traceable standards according to ISO 10012-1 and ANSI/NCSL 2540-1, as applicable.

All contents contained herein are the property of Samtec. No portion of this report, in part or in full shall be reproduced without prior written approval of Samtec.

### SCOPE

To perform the following tests: Design Qualification test. Please see test plan.

### APPLICABLE DOCUMENTS

Standards: EIA Publication 364

### TEST SAMPLES AND PREPARATION

- 1) All materials were manufactured in accordance with the applicable product specification.
- 2) All test samples were identified and encoded to maintain traceability throughout the test sequences.
- 3) After soldering, the parts to be used for LLCR and DWV/IR testing were cleaned according to TLWI-0001.
- 4) Either an automated cleaning procedure or an ultrasonic cleaning procedure may be used.
- 5) The automated procedure is used with aqueous compatible soldering materials.
- 6) Parts not intended for testing LLCR and DWV/IR are visually inspected and cleaned if necessary.
- 7) Any additional preparation will be noted in the individual test sequences.
- 8) Solder Information: Lead free
- 9) Samtec Test PCBs used: PCB-109327-TST, PCB-109328-TST.

## FLOWCHARTS

### Thermal Aging

#### Group 1

RSP-122811-03

MH081-MH4RP-505050-0190

8 Assemblies

---

Step	Description
1.	Contact Gaps
2.	Mating/Unmating Force <sup>(2)</sup>
3.	LLCR <sup>(1)</sup> - Non Standard
4.	Thermal Age <sup>(3)</sup> - Non Standard
5.	LLCR <sup>(1)</sup> - Non Standard Max Delta = 15 mOhm
6.	Mating/Unmating Force <sup>(2)</sup>
7.	Contact Gaps

---

-----  
(1) LLCR = Other

Open Circuit Voltage = 20 mV Max

Test Current = 10 mA Max

LLCR Current=10 mA Max

(2) Mating/Unmating Force = EIA-364-13

(3) Thermal Age = Other

Test Condition = 4 (90°C)

Time Condition = B (96 Hours)

**FLOWCHARTS Continued****Mating/Unmating/Durability**Group 1

RSP-122811-03

MH081-MH4RP-505050-0190

8 Assemblies

Step	Description
1.	Contact Gaps
2.	LLCR <sup>(2)</sup> - Non Standard
3.	Mating/Unmating Force <sup>(3)</sup> <i>Note: Un-mating force: Initial: 4N MIN.</i>
4.	Cycles Quantity = 30 Cycles <i>Note: Per I-PEX SPEC.</i>
5.	Mating/Unmating Force <sup>(3)</sup> <i>Note: After 30 cycles: 2N MIN.</i>
6.	Contact Gaps
7.	LLCR <sup>(2)</sup> - Non Standard Max Delta = 15 mOhm
8.	Thermal Shock <sup>(4)</sup> - Non Standard <i>Note: Non-standard</i>
9.	LLCR <sup>(2)</sup> - Non Standard Max Delta = 15 mOhm
10.	Humidity <sup>(1)</sup> - Non Standard
11.	LLCR <sup>(2)</sup> - Non Standard Max Delta = 15 mOhm
12.	Mating/Unmating Force <sup>(3)</sup>

-----  
(1) Humidity = Other

Test Condition = B (96 Hours)

Test Method (40°C+/-2°C @ 90% RH to 95% RH)

(2) LLCR = Other

Open Circuit Voltage = 20 mV Max

Test Current = 10 mA Max

LLCR Current=10 mA Max

(3) Mating/Unmating Force = EIA-364-13

(4) Thermal Shock = Other

Exposure Time at Temperature Extremes = 1/2 Hour

Method A, Test Condition = I (-55°C to +85°C)

Test Duration = A-3 (5 Cycles)

**FLOWCHARTS Continued****IR/DWV****Pin-to-Ground****Group 1**

MH081-MH4RP-505050-0190

RSP-122811-03

2 Assemblies

Step	Description
1.	IR (3) - Non Standard
2.	DWV at Test Voltage <sup>(1)</sup> - Non Standard Test Voltage = 200 V <i>Note: DWV test voltage = 200V rms for 1 minute</i>
3.	Thermal Shock <sup>(4)</sup> - Non Standard <i>Note: Non-standard.</i>
4.	IR (3) - Non Standard
5.	DWV at Test Voltage <sup>(1)</sup> - Non Standard Test Voltage = 200 V <i>Note: DWV test voltage = 200V rms for 1 minute</i>
6.	Humidity <sup>(2)</sup> - Non Standard
7.	IR (3) - Non Standard
8.	DWV at Test Voltage <sup>(1)</sup> - Non Standard Test Voltage = 200 V <i>Note: DWV test voltage = 200V rms for 1 minute</i>

---

(1) DWV at Test Voltage = EIA-364-20

Test Condition = 1 (Sea Level)

DWV test voltage is equal to 75% of the lowest breakdown voltage

Test voltage applied for 60 seconds

(2) Humidity = Other

Test Condition = B (96 Hours) Test Method (40°C+/-2°C @ 90% RH to 95% RH)

(3) IR = Other

Test Condition = 100 Vdc, 2 Minutes Max

(4) Thermal Shock = Other

Exposure Time at Temperature Extremes = 1/2 Hour

Method A, Test Condition = 1 (-55°C to +85°C)

Test Duration = A-3 (5 Cycles)

**FLOWCHARTS Continued****Cable Pull**Group 1

RSP-122811-03

MH081-MH4RP-505050-0190

5 Assemblies

0 Degrees

**Step Description**

1. Cable Pull <sup>(1)</sup> - Non Standard

---

(1) Cable Pull = Other

Pull the cable at speed of 25±3mm/minutes by the tensile strength machine and measure the retention force.  
Retention force 5N Min.

**Solderability**Group 1

MHF4-J-P-F-ST-SM1

5 Assemblies

Lead Free Solder

**Step Description**

1. Precondition
2. Solderability <sup>(2)</sup>  
Leaded Or Lead Free = Lead Free Solder
3. Visual Inspection
4. Photos <sup>(1)</sup>

---

(1) Photos

Attach 2-3 photos of contact area

(2) Solderability = JESD22-B102

Precondition = E (150°C, 16 Hours)

**FLOWCHARTS Continued****Cable Retention Force**Group 1

RSP-122811-03

MH081-MH4RP-505050-0190

6 Assemblies

0 Degrees

**Step Description**

1. Cable Pull (1) - Non Standard  
*Note: Appearance: No abnormality  
 Electrical discontinuity: No  
 electrical discontinuity greater  
 than 1 uS shall occur.*

Group 2

RSP-122811-03

MH081-MH4RP-505050-0190

6 Assemblies

90 Degrees

**Step Description**

1. Cable Pull (1) - Non Standard  
*Note: Appearance: No abnormality  
 Electrical discontinuity: No  
 electrical discontinuity greater  
 than 1 uS shall occur.*

(1) Cable Pull = Other

Apply force (2N Max.) to the cable; During the testing, run 100mA DC to check electrical discontinuity.

Appearance: No abnormality; Electrical discontinuity: No electrical discontinuity greater than 1 uS shall occur.

## ATTRIBUTE DEFINITIONS

The following is a brief, simplified description of attributes.

### THERMAL SHOCK:

- 1) EIA-364-32, *Thermal Shock (Temperature Cycling) Test Procedure for Electrical Connectors*.
- 2) Test Condition 1: -55°C to +85°C
- 3) Test Time: ½ hour dwell at each temperature extreme
- 4) Number of Cycles: 5
- 5) All test samples are pre-conditioned at ambient.
- 6) All test samples are exposed to environmental stressing in the mated condition.

### THERMAL:

- 1) EIA-364-17, *Temperature Life with or without Electrical Load Test Procedure for Electrical Connectors*.
- 2) Test Condition 4 at 90° C
- 3) Test Time Condition B for 96 hours.
- 4) All test samples are pre-conditioned at ambient.
- 5) All test samples are exposed to environmental stressing in the mated condition.

### HUMIDITY:

- 1) Reference document: EIA-364-31, *Humidity Test Procedure for Electrical Connectors*.
- 2) Test Condition B, 240 Hours.
- 3) Method III, 40+/-2° C, 90% to 95% Relative Humidity excluding sub-cycles 7a and 7b.
- 4) All samples are pre-conditioned at ambient.
- 5) All test samples are exposed to environmental stressing in the mated condition.

### MATING/UNMATING:

- 1) Reference document: EIA-364-13, *Mating and Unmating Forces Test Procedure for Electrical Connectors*.
- 2) The full insertion position was to within 0.003” to 0.004” of the plug bottoming out in the receptacle to prevent damage to the system under test.
- 3) One of the mating parts is secured to a floating X-Y table to prevent damage during cycling.

### LLCR:

- 1) EIA-364-23, *Low Level Contact Resistance Test Procedure for Electrical Connectors and Sockets*.
- 2) A computer program, *LLCR 221.exe*, ensures repeatability for data acquisition.
- 3) The following guidelines are used to categorize the changes in LLCR as a result from stressing
  - a. <= +5.0 mOhms:----- Stable
  - b. +5.1 to +10.0 mOhms:----- Minor
  - c. +10.1 to +15.0 mOhms:----- Acceptable
  - d. +15.1 to +50.0 mOhms:----- Marginal
  - e. +50.1 to +2000 mOhms:----- Unstable
  - f. >+2000 mOhms:----- Open Failure

### ATTRIBUTE DEFINITIONS Continued

The following is a brief, simplified description of attributes.

#### INSULATION RESISTANCE (IR):

To determine the resistance of insulation materials to leakage of current through or on the surface of these materials when a DC potential is applied.

- 1) PROCEDURE:
  - a. Reference document: EIA-364-21, *Insulation Resistance Test Procedure for Electrical Connectors*.
  - b. Test Conditions:
    - i. Between Adjacent Contacts or Signal-to-Ground
    - ii. Electrification Time 2.0 minutes
    - iii. Test Voltage (200 VDC) corresponds to calibration settings for measuring resistances.
- 2) MEASUREMENTS:
- 3) When the specified test voltage is applied (VDC), the insulation resistance shall not be less than 5000 megohms.

#### DIELECTRIC WITHSTANDING VOLTAGE (DWV):

To determine if the sockets can operate at its rated voltage and withstand momentary over potentials due to switching, surges, and other similar phenomenon. Separate samples are used to evaluate the effect of environmental stresses so not to influence the readings from arcing that occurs during the measurement process.

- 1) PROCEDURE:
  - a. Reference document: EIA-364-20, *Withstanding Voltage Test Procedure for Electrical Connectors*.
  - b. Test Conditions:
    - i. Between Adjacent Contacts or Signal-to-Ground
    - ii. Barometric Test Condition 1
    - iii. Rate of Application 500 V/Sec
    - iv. Test Voltage (VAC) until breakdown occurs
- 2) MEASUREMENTS/CALCULATIONS
  - a. The breakdown voltage shall be measured and recorded.
  - b. The dielectric withstanding voltage shall be recorded as 75% of the minimum breakdown voltage.
  - c. The working voltage shall be recorded as one-third (1/3) of the dielectric withstanding voltage (one-fourth of the breakdown voltage).

**RESULTS****Mating – Unmating Forces****Thermal Aging Group**

- **Initial**
  - **Mating**
    - **Min** ----- 1.79 Lbs
    - **Max** ----- 2.12 Lbs
  - **Unmating**
    - **Min** ----- 1.69 Lbs
    - **Max** ----- 1.98 Lbs
- **After Thermal**
  - **Mating**
    - **Min** ----- 1.45 Lbs
    - **Max** ----- 1.87 Lbs
  - **Unmating**
    - **Min** ----- 1.33 Lbs
    - **Max** ----- 2.05 Lbs

**Mating-Unmating Durability Group**

- **Initial**
  - **Mating**
    - **Min** ----- 1.61 Lbs
    - **Max** ----- 2.23 Lbs
  - **Unmating**
    - **Min** ----- 1.24 Lbs
    - **Max** ----- 1.94 Lbs
- **After 30 Cycles**
  - **Mating**
    - **Min** ----- 1.57 Lbs
    - **Max** ----- 1.94 Lbs
  - **Unmating**
    - **Min** ----- 1.41 Lbs
    - **Max** ----- 1.76 Lbs
- **Humidity**
  - **Mating**
    - **Min** ----- 1.26 Lbs
    - **Max** ----- 1.45 Lbs
  - **Unmating**
    - **Min** ----- 1.20 Lbs
    - **Max** ----- 1.45 Lbs

**Cable Pull Group****0° Pull**

- **Min** ----- 6.63 N
- **Max** ----- 7.92 N

**Cable Retention Force**

- **0° Pull**----- 2.00 N ----- No Electrical discontinuity greater than 1 microsecond
- **90° Pull**----- 2.00 N ----- No Electrical discontinuity greater than 1 microsecond

**RESULTS Continued****Insulation Resistance minimums, IR****Pin to Ground**

- **Initial**
  - Mated----- 9000 Meg  $\Omega$  ----- Passed
  - Unmated ----- 9000 Meg  $\Omega$  ----- Passed
- **Thermal Shock**
  - Mated----- 9000 Meg  $\Omega$  ----- Passed
  - Unmated ----- 9000 Meg  $\Omega$  ----- Passed
- **Humidity**
  - Mated----- 9000 Meg  $\Omega$  ----- Passed
  - Unmated ----- 9000 Meg  $\Omega$  ----- Passed

**Dielectric Withstanding Voltage minimums, DWV**

- **Minimums**
  - Breakdown Voltage-----266VAC
  - Test Voltage -----200 VAC
  - Working Voltage ----- 65 VAC

**Pin to Ground**

- **Initial DWV** -----Passed
- **Thermal DWV**-----Passed
- **Humidity DWV**-----Passed

**RESULTS Continued****LLCR Thermal Aging Group (16 LLCR test points)****Signal Pin:**

- Initial ----- 58.39 mOhms Max

**Ground Pin:**

- Initial ----- 244.97 mOhms Max
- Thermal
  - <= +5.0 mOhms ----- 15 Points ----- Stable
  - +5.1 to +10.0 mOhms ----- 1 Points ----- Minor
  - +10.1 to +15.0 mOhms ----- 0 Points ----- Acceptable
  - +15.1 to +50.0 mOhms ----- 0 Points ----- Marginal
  - +50.1 to +2000 mOhms ----- 0 Points ----- Unstable
  - >+2000 mOhms ----- 0 Points ----- Open Failure

**LLCR Mating/Unmating Durability Group (16 LLCR test points)****Signal Pin:**

- Initial ----- 58.27 mOhms Max

**Ground Pin:**

- Initial ----- 240.43 mOhms Max
- Durability, 30 Cycles
  - <= +5.0 mOhms ----- 10 Points ----- Stable
  - +5.1 to +10.0 mOhms ----- 6 Points ----- Minor
  - +10.1 to +15.0 mOhms ----- 0 Points ----- Acceptable
  - +15.1 to +50.0 mOhms ----- 0 Points ----- Marginal
  - +50.1 to +2000 mOhms ----- 0 Points ----- Unstable
  - >+2000 mOhms ----- 0 Points ----- Open Failure
- Thermal Shock
  - <= +5.0 mOhms ----- 5 Points ----- Stable
  - +5.1 to +10.0 mOhms ----- 9 Points ----- Minor
  - +10.1 to +15.0 mOhms ----- 2 Points ----- Acceptable
  - +15.1 to +50.0 mOhms ----- 0 Points ----- Marginal
  - +50.1 to +2000 mOhms ----- 0 Points ----- Unstable
  - >+2000 mOhms ----- 0 Points ----- Open Failure
- Humidity
  - <= +5.0 mOhms ----- 7 Points ----- Stable
  - +5.1 to +10.0 mOhms ----- 9 Points ----- Minor
  - +10.1 to +15.0 mOhms ----- 0 Points ----- Acceptable
  - +15.1 to +50.0 mOhms ----- 0 Points ----- Marginal
  - +50.1 to +2000 mOhms ----- 0 Points ----- Unstable
  - >+2000 mOhms ----- 0 Points ----- Open Failure

**Test Picture**

**Solderability**

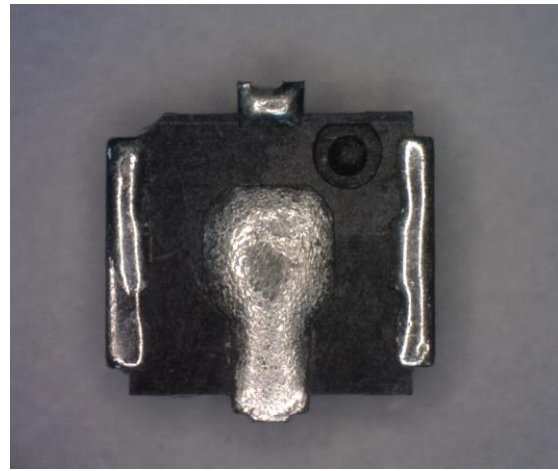
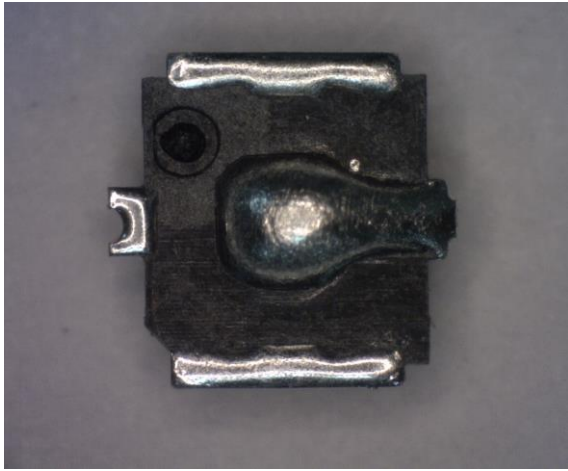
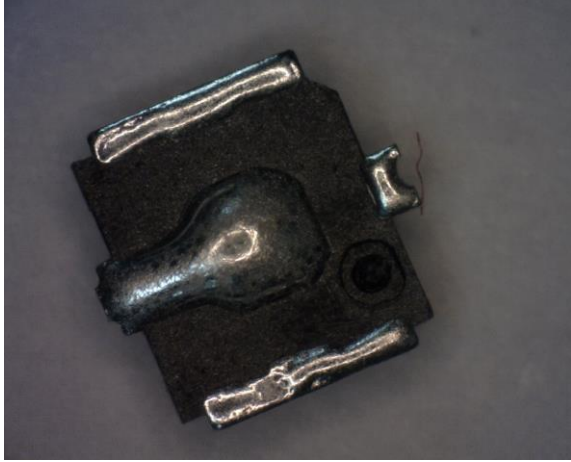

**DATA SUMMARIES****MATING-UNMATING FORCE:****Thermal Aging Group**

	Initial				After Thermals			
	Mating		Unmating		Mating		Unmating	
	Newton's	Force (Lbs)	Newton's	Force (Lbs)	Newton's	Force (Lbs)	Newton's	Force (Lbs)
Minimum	7.96	1.79	7.52	1.69	6.45	1.45	5.92	1.33
Maximum	9.43	2.12	8.81	1.98	8.32	1.87	9.12	2.05
<b>Average</b>	<b>8.51</b>	<b>1.91</b>	<b>8.00</b>	<b>1.80</b>	<b>7.11</b>	<b>1.60</b>	<b>7.81</b>	<b>1.76</b>
St Dev	0.51	0.11	0.42	0.09	0.62	0.14	1.09	0.25
Count	8	8	8	8	8	8	8	8

**Mating-Unmating Durability Group**

	Initial				After 30 Cycles			
	Mating		Unmating		Mating		Unmating	
	Newton's	Force (Lbs)	Newton's	Force (Lbs)	Newton's	Force (Lbs)	Newton's	Force (Lbs)
Minimum	7.16	1.61	5.52	1.24	6.98	1.57	6.27	1.41
Maximum	9.92	2.23	8.63	1.94	8.63	1.94	7.83	1.76
<b>Average</b>	<b>8.49</b>	<b>1.91</b>	<b>7.61</b>	<b>1.71</b>	<b>7.99</b>	<b>1.80</b>	<b>7.11</b>	<b>1.60</b>
St Dev	0.85	0.19	1.01	0.23	0.56	0.13	0.59	0.13
Count	8	8	8	8	8	8	8	8

	After Humidity			
	Mating		Unmating	
	Newton's	Force (Lbs)	Newton's	Force (Lbs)
Minimum	5.60	1.26	5.34	1.20
Maximum	6.45	1.45	6.45	1.45
<b>Average</b>	<b>6.03</b>	<b>1.36</b>	<b>5.83</b>	<b>1.31</b>
St Dev	0.29	0.07	0.39	0.09
Count	8	8	8	8

**Cable Pull****0° Pull**

	Force (N)
Minimum	<b>6.63</b>
Maximum	7.92
Average	7.17

**DATA SUMMARIES Continued****INSULATION RESISTANCE (IR):**

	Pin to Ground		
	Mated	Unmated	Unmated
Minimum	RSP /MH081	RSP	MH081
Initial	9000	9000	9000
Thermal	9000	9000	9000
Humidity	6500	6800	9000

**DIELECTRIC WITHSTANDING VOLTAGE (DWV):**

Voltage Rating Summary	
Minimum	RSP/MH081
Break Down Voltage	266
Test Voltage	200
Working Voltage	65

Pin to Ground	
Initial Test Voltage	Passed
After Thermal Test Voltage	Passed
After Humidity Test Voltage	Passed

**DATA SUMMARIES Continued****LLCR Thermal Aging Group**

- 1) A total of 16 points were measured.
- 2) EIA-364-23, *Low Level Contact Resistance Test Procedure for Electrical Connectors and Sockets*.
- 3) A computer program, *LLCR 221.exe*, ensures repeatability for data acquisition.
- 4) The following guidelines are used to categorize the changes in LLCR as a result from stressing.
  - a.  $\leq +5.0$  mOhms:-----Stable
  - b.  $+5.1$  to  $+10.0$  mOhms:-----Minor
  - c.  $+10.1$  to  $+15.0$  mOhms:-----Acceptable
  - d.  $+15.1$  to  $+50.0$  mOhms:-----Marginal
  - e.  $+50.1$  to  $+2000$  mOhms-----Unstable
  - f.  $>+2000$  mOhms:-----Open Failure

<b>LLCR Measurement Summaries by Pin Type</b>				
Date	10/30/2018	11/5/2018		
Room Temp (Deg C)	23	23		
Rel Humidity (%)	54	55		
Technician	Peter Chen	Peter Chen		
<b>mOhm values</b>	<b>Actual Initial</b>	<b>Delta Thermal</b>	<b>Delta</b>	<b>Delta</b>
<b>Pin Type 1: Ground</b>				
Average	54.16	3.57		
St. Dev.	1.67	1.16		
Min	53.02	1.96		
Max	58.39	5.54		
Summary Count	8	8		
Total Count	8	8		
<b>Pin Type 2: Signal</b>				
Average	240.59	1.52		
St. Dev.	1.89	0.97		
Min	238.54	0.14		
Max	244.97	2.89		
Summary Count	8	8		
Total Count	8	8		

<b>LLCR Delta Count by Category</b>						
	<b>Stable</b>	<b>Minor</b>	<b>Acceptable</b>	<b>Marginal</b>	<b>Unstable</b>	<b>Open</b>
<b>mOhms</b>	<b><math>\leq 5</math></b>	<b><math>&gt;5</math> &amp; <math>\leq 10</math></b>	<b><math>&gt;10</math> &amp; <math>\leq 15</math></b>	<b><math>&gt;15</math> &amp; <math>\leq 50</math></b>	<b><math>&gt;50</math> &amp; <math>\leq 1000</math></b>	<b><math>&gt;1000</math></b>
<b>Thermal</b>	<b>15</b>	<b>1</b>	<b>0</b>	<b>0</b>	<b>0</b>	<b>0</b>

**DATA SUMMARIES Continued****LLCR Mating/Unmating Durability Group (ERF8-030-09.0-L-DV/ERM8-030-09.0-L-DV)**

- 1). A total of 16 points were measured.
- 2). EIA-364-23, *Low Level Contact Resistance Test Procedure for Electrical Connectors and Sockets*.
- 3). A computer program, *LLCR 221.exe*, ensures repeatability for data acquisition.
- 4). The following guidelines are used to categorize the changes in LLCR as a result from stressing.
  - a.  $\leq +5.0$  mOhms: ----- Stable
  - b.  $+5.1$  to  $+10.0$  mOhms: ----- Minor
  - c.  $+10.1$  to  $+15.0$  mOhms: ----- Acceptable
  - d.  $+15.1$  to  $+50.0$  mOhms: ----- Marginal
  - e.  $+50.1$  to  $+2000$  mOhms ----- Unstable
  - f.  $> +2000$  mOhms: ----- Open Failure

<b>LLCR Measurement Summaries by Pin Type</b>				
Date	10/29/2018	10/31/2018	11/1/2018	11/12/2018
Room Temp (Deg C)	23	23	24	23
Rel Humidity (%)	57	54	55	55
Technician	Peter Chen	Peter Chen	Peter Chen	Peter Chen
<b>mOhm values</b>	<b>Actual Initial</b>	<b>Delta 30 Cycles</b>	<b>Delta Therm Shck</b>	<b>Delta Humidity</b>
<b>Pin Type 1: Ground</b>				
Average	54.92	5.56	4.30	3.14
St. Dev.	1.45	2.56	3.44	1.93
Min	53.25	1.21	0.84	0.09
Max	58.27	9.84	11.30	5.81
Summary Count	8	8	8	8
Total Count	8	8	8	8
<b>Pin Type 2: Signal</b>				
Average	238.61	3.45	8.03	7.56
St. Dev.	0.86	1.38	1.41	2.04
Min	237.22	1.38	6.31	4.78
Max	240.43	6.08	10	9.68
Summary Count	8	8	8	8
Total Count	8	8	8	8

<b>LLCR Delta Count by Category</b>						
mOhms	Stable	Minor	Acceptable	Marginal	Unstable	Open
	$\leq 5$	$>5$ & $\leq 10$	$>10$ & $\leq 15$	$>15$ & $\leq 50$	$>50$ & $\leq 1000$	$>1000$
<b>30 Cycles</b>	10	6	0	0	0	0
<b>Therm Shck</b>	5	9	2	0	0	0
<b>Humidity</b>	7	9	0	0	0	0

b

**EQUIPMENT AND CALIBRATION SCHEDULES****Equipment #:** DG-HPM-02**Description:** Hipot Safety Tester**Manufacturer:** Vitrek**Model:** V73**Serial #:** 025866**Accuracy:** Last Cal: 2018-4-27, Next Cal: 2019-4-26**Equipment #:** HZ-MO-03**Description:** Micro-ohmmeter**Manufacturer:** Keithley**Model:** 580**Serial #:** 297288**Accuracy:** Last Cal: 2018-8-06, Next Cal: 2019-8-05**Equipment #:** HZ-TCT-01**Description:** Normal force analyzer**Manufacturer:** Mecmesin Multitester**Model:** Mecmesin Multitester 2.5-i**Serial #:** 08-1049-04**Accuracy:** Last Cal: 2018-4-28, Next Cal: 2019-4-27**Equipment #:** HZ-OV-01**Description:** Oven**Manufacturer:** Huida**Model:** CS101-1E**Serial #:** CS101-1E-B**Accuracy:** Last Cal: 2018-12-14, Next Cal: 2019-12-13**Equipment #:** HZ-THC-01**Description:** Humidity transmitter**Manufacturer:** Thermtron**Model:** HMM30C**Serial #:** D0240037**Accuracy:** Last Cal: 2018-3-3, Next Cal: 2019-3-2**Equipment #:** HZ-MO-01**Description:** Micro-ohmmeter**Manufacturer:** Keithley**Model:** 2700**Serial #:** 1199807**Accuracy:** Last Cal: 2018-4-28, Next Cal: 2019-4-27

**EQUIPMENT AND CALIBRATION SCHEDULES****Equipment #:** HZ-PS-01**Description:** Power Supply**Manufacturer:** Agilent**Model:** 6031A**Serial #:** MY41000982**Accuracy:** Last Cal: 2018-4-28, Next Cal: 2019-4-27**Equipment #:** HZ-TSC-01**Description:** Thermal Shock transmitter**Manufacturer:** Keithley**Model:** 10-VT14994**Serial #:** VTS-3-6-6-SC/AC**Accuracy:** Last Cal: 2018-11-1, Next Cal: 2019-11-1