

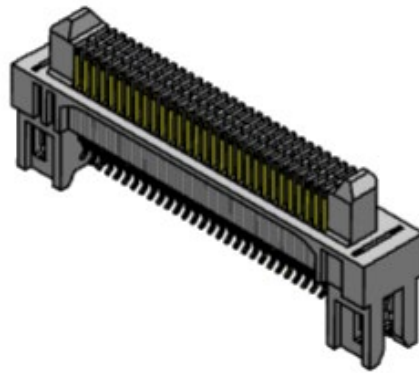

High Speed Characterization Report

ERM8-XXX-01-L-D-EM2



ERF8-XXX-05.0-L-DV

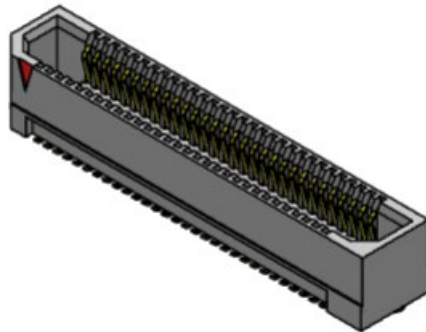

Description:
**0.80 mm Edge Rate® Rugged High-Speed Interconnect,
Edge-Mount Terminal mating to Vertical Socket**

Series: ERM8_EM / ERF8**Description:** 0.80 mm Edge Rate® Rugged High-Speed Interconnect,
Edge-Mount Terminal mating to Vertical Socket

Table of Contents

Connector Overview.....	1
Frequency Domain Data Summary.....	1
Bandwidth Chart – Differential Insertion Loss.....	1
Time Domain Data Summary.....	2
Table 1 - Differential Impedance (Ω).....	2
Table 2 - Differential Crosstalk (%).....	3
Table 3 - Propagation Delay (Mated Connector).....	3
Characterization Details.....	4
Differential and Single-Ended Data.....	4
Connector Signal to Ground Ratio.....	4
Frequency Domain Data.....	5
Time Domain Data.....	6
Appendix A – Frequency Domain Responses.....	7
Differential Application – Insertion Loss.....	7
Differential Application – Return Loss.....	8
Differential Application – NEXT Configurations.....	9
Differential Application – FEXT Configurations.....	10
Appendix B – Time Domain Responses.....	12
Differential Application – Impedance.....	12
Differential Application – Propagation Delay.....	15
Appendix C – Product and Test System Descriptions.....	18
Product Description.....	18
Test System Description.....	18
PCB-ERx8DV-111332-SIG-0 Test Fixtures.....	18
PCB Fixtures.....	19
Appendix D – Test and Measurement Setup.....	21
N5225B Measurement Setup.....	21
Test Instruments.....	21
Test Cables & Adapters.....	21
Appendix E - Frequency and Time Domain Measurements.....	22
Frequency (S-Parameter) Domain Procedures.....	22
Time Domain Procedures.....	22
Impedance (TDR).....	22
Propagation Delay (TDT).....	22
Appendix F – Glossary of Terms.....	23

Series: ERM8_EM / ERF8

Description: 0.80 mm Edge Rate® Rugged High-Speed Interconnect,
Edge-Mount Terminal mating to Vertical Socket

Connector Overview

The ERx8 is a board-mounted header designed for use in high-speed systems. The ERx8 uses the Edge Rate® contact system which is designed for 56 Gbps PAM4 performance. The ERx8 Series are available in 5, 10, 11, 13, 20, 25, 30, 35, 40, 49, 50, 60, 70 and 75 positions per row. ERx8 series connector include double row vertical, right angle and edge-mount styles. The data in this report is applicable only to the male edge mount mated to double row vertical female connector.

Frequency Domain Data Summary

Bandwidth Chart – Differential Insertion Loss

ERx8 Connector Series

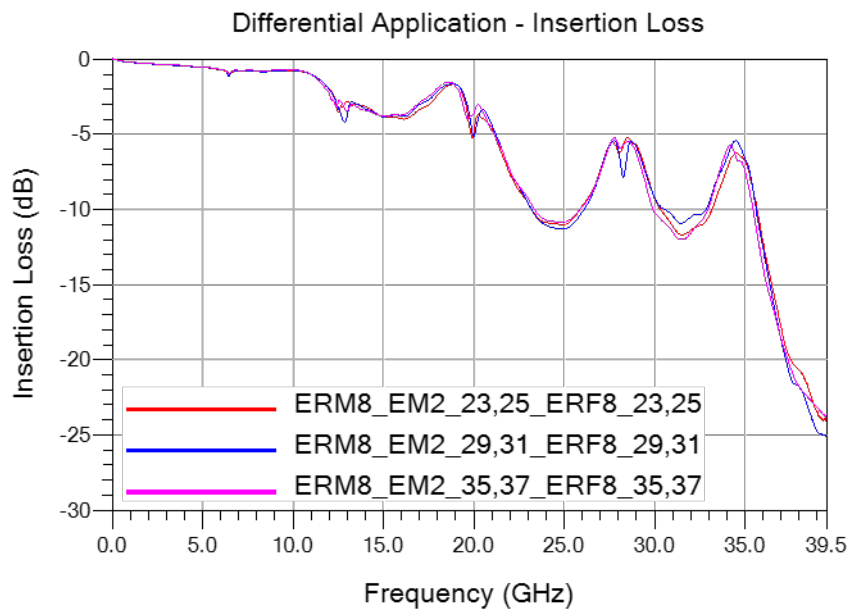

Figure 1

Series: ERM8_EM / ERF8

Description: 0.80 mm Edge Rate® Rugged High-Speed Interconnect,
Edge-Mount Terminal mating to Vertical Socket

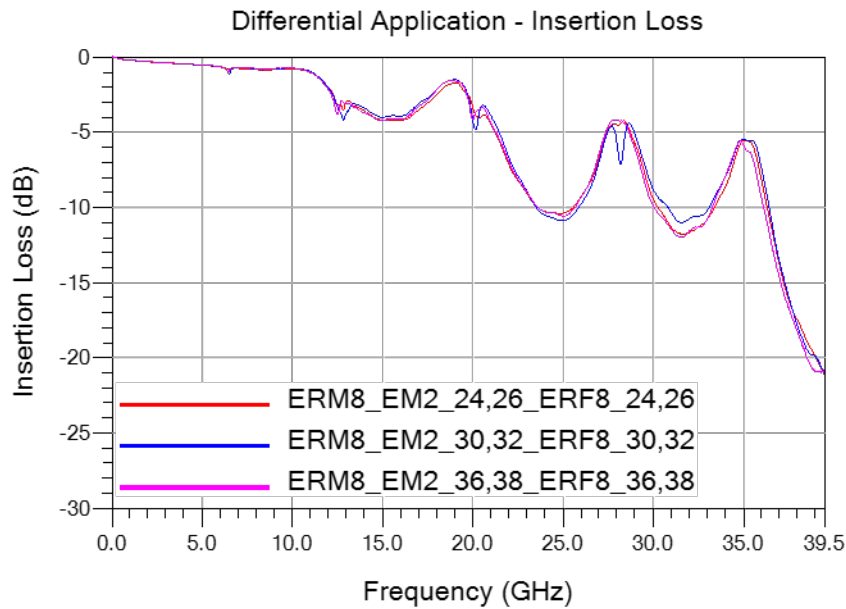

Figure 2

Time Domain Data Summary

Table 1 - Differential Impedance (Ω)				
Driver	Signal Rise-time	30ps	50ps	100ps
ERM8_EM2_23,25	Maximum Impedance	109.2	104.3	102.2
	Minimum Impedance	90.7	92.8	96.0
ERM8_EM2_24,26	Maximum Impedance	107.9	103.7	102.2
	Minimum Impedance	90.4	92.6	95.5
ERM8_EM2_29,31	Maximum Impedance	109.3	104.7	102.4
	Minimum Impedance	89.7	92.2	95.6
ERM8_EM2_30,32	Maximum Impedance	108.2	104.0	102.4
	Minimum Impedance	89.7	92.3	95.3
ERM8_EM2_35,37	Maximum Impedance	109.2	104.4	102.3
	Minimum Impedance	89.0	92.0	95.5
ERM8_EM2_36,38	Maximum Impedance	108.1	104.0	102.2
	Minimum Impedance	89.7	92.4	95.2

Series: ERM8_EM / ERF8

Description: 0.80 mm Edge Rate® Rugged High-Speed Interconnect,
Edge-Mount Terminal mating to Vertical Socket

Table 2 - Differential Crosstalk (%)						
Input(tr)	Driver	Receiver	30ps	50ps	100ps	
NEXT	ERM8 EM2 23,25	ERM8 EM2 24,26	0.16	0.13	0.11	
	ERM8 EM2 23,25	ERM8 EM2 29,31	0.43	0.37	0.29	
	ERM8 EM2 23,25	ERM8 EM2 30,32	0.21	0.14	<0.1	
	ERM8 EM2 23,25	ERM8 EM2 35,37	<0.1	<0.1	<0.1	
	ERM8 EM2 23,25	ERM8 EM2 36,38	<0.1	<0.1	<0.1	
	ERM8 EM2 29,31	ERM8 EM2 24,26	0.18	0.12	<0.1	
	ERM8 EM2 29,31	ERM8 EM2 30,32	0.18	0.14	0.11	
	ERM8 EM2 29,31	ERM8 EM2 35,37	0.45	0.37	0.29	
	ERM8 EM2 29,31	ERM8 EM2 36,38	0.18	0.11	<0.1	
	ERM8 EM2 35,37	ERM8 EM2 24,26	<0.1	<0.1	<0.1	
	ERM8 EM2 35,37	ERM8 EM2 30,32	0.14	<0.1	<0.1	
	ERM8 EM2 35,37	ERM8 EM2 36,38	0.22	0.17	0.13	
FEXT	ERM8 EM2 23,25	ERF8 24,26	0.17	<0.1	<0.1	
	ERM8 EM2 23,25	ERF8 29,31	0.23	0.13	<0.1	
	ERM8 EM2 23,25	ERF8 30,32	0.26	0.17	<0.1	
	ERM8 EM2 23,25	ERF8 35,37	<0.1	<0.1	<0.1	
	ERM8 EM2 23,25	ERF8 36,38	<0.1	<0.1	<0.1	
	ERM8 EM2 29,31	ERF8 24,26	0.26	0.17	<0.1	
	ERM8 EM2 29,31	ERF8 30,32	0.36	0.25	0.14	
	ERM8 EM2 29,31	ERF8 35,37	0.21	0.12	<0.1	
	ERM8 EM2 29,31	ERF8 36,38	0.20	0.12	<0.1	
	ERM8 EM2 35,37	ERF8 24,26	<0.1	<0.1	<0.1	
	ERM8 EM2 35,37	ERF8 30,32	0.19	0.12	<0.1	
	ERM8 EM2 35,37	ERF8 36,38	0.11	<0.1	<0.1	

Table 3 - Propagation Delay (Mated Connector)		
ERM8 EM2 23,25	ERF8 23,25	153 ps
ERM8 EM2 24,26	ERF8 24,26	153 ps
ERM8 EM2 29,31	ERF8 29,31	153 ps
ERM8 EM2 30,32	ERF8 30,32	153 ps
ERM8 EM2 35,37	ERF8 35,37	152 ps
ERM8 EM2 36,38	ERF8 36,38	152 ps

Series: ERM8_EM / ERF8

Description: 0.80 mm Edge Rate® Rugged High-Speed Interconnect,
Edge-Mount Terminal mating to Vertical Socket

Characterization Details

This report presents data that characterizes the signal integrity response of a connector pair in a controlled printed circuit board (PCB) environment. All efforts are made to reveal typical best-case responses inherent to the system under test (SUT).

In this report, the SUT includes the connector pair and footprint effects on a typical multi-layer PCB. PCB effects (trace loss) are de-embedded from test data. Board related effects, such as pad-to-ground capacitance, are included in the data presented in this report.

Additionally, intermediate test signal connections can mask the connector's true performance. Such connection effects are minimized by using high performance test cables and adapters. Where appropriate, calibration and de-embedding routines are also used to reduce residual effects.

Differential and Single-Ended Data

Most Samtec connectors can be used successfully in both differential and single-ended applications. However, electrical performance will differ depending on the signal drive type. In this report, data is presented for differentially driven scenarios.

Connector Signal to Ground Ratio

Samtec connectors are most often designed for generic applications and can be implemented using various signal and ground pin assignments. In high-speed systems, provisions must be made in the interconnect for signal return currents. Such paths are often referred to as "ground." In some connectors, a ground plane or blade, or an outer shield, is used as the signal return, while in others, connector pins are used as signal returns. Various combinations of signal pins, ground blades, and shields can also be utilized. Electrical performance can vary significantly depending upon the number and location of ground pins.

In general, the more pins dedicated to ground, the better electrical performance will be. But dedicating pins to ground reduces signal density of a connector. Therefore, care must be taken when choosing signal/ground ratios in cost or density-sensitive applications.

Series: ERM8_EM / ERF8

Description: 0.80 mm Edge Rate® Rugged High-Speed Interconnect,
Edge-Mount Terminal mating to Vertical Socket

For this connector, the following configurations were evaluated:

1	3	5	7	9	11	13	15	T	T	G	23	25	G	29	31	G	35	37	G	T	T	45	47	49	51	53	55	57	59
2	4	6	8	10	12	14	16	T	T	G	24	26	G	30	32	G	36	38	G	T	T	46	48	50	52	54	56	58	60

Differential Impedance (denoted by blue circles):

- GSSG (Ground-positive Signal-negative Signal-Ground)

Differential Crosstalk (denoted by red circles):

- In row: from the terminals to the other terminals on the same row.
- Across row: from one row of terminals to the other row of terminals.

In a real system environment, active signals might be located at the outer edges of the signal contacts of concern, as opposed to the ground signals utilized in laboratory testing. For example, in a single-ended system, a pin-out of “SSSS,” or four adjacent single ended signals might be encountered as opposed to the “GSG” and “GSSG” configurations tested in the laboratory. Electrical characteristics in such applications could vary slightly from laboratory results. But in most applications, performance can safely be considered equivalent.

Signal Edge Speed (Rise Time):

In pulse signaling applications, the perceived performance of the interconnect can vary significantly depending on the edge rate or rise time of the exciting signal. For this report, the fastest rise time used was 30 ps. Generally, this should demonstrate worst-case performance.

In many systems, the signal edge rate will be significantly slower at the connector than at the driver launch point. To estimate interconnect performance at other edge rates, data is provided for several rise times between 30 ps and 100 ps.

For this report, measured rise times were at 20%-80% signal levels.

Frequency Domain Data

Frequency Domain parameters are helpful in evaluating the connector system’s signal loss and crosstalk characteristics across a range of sinusoidal frequencies. In this report, parameters presented in the Frequency Domain are Insertion Loss, Return Loss, and Near-End and Far-End Crosstalk. Other parameters or formats, such as VSWR or S-Parameters, may be available upon request. Please contact our Signal Integrity Group at sig@samtec.com for more information.

Series: ERM8_EM / ERF8

Description: 0.80 mm Edge Rate® Rugged High-Speed Interconnect,
Edge-Mount Terminal mating to Vertical Socket

Frequency performance characteristics for the SUT are generated directly from network analyzer measurements.

Time Domain Data

Time Domain parameters indicate Impedance mismatch versus length, signal propagation time, and crosstalk in a pulsed signal environment. The measured S-Parameters from the network analyzer are post-processed using Keysight Advanced Design System to obtain the time domain response. Time Domain procedure is provided in [Appendix E](#) of this report. Parameters or formats not included in this report may be available upon request. Please contact our Signal Integrity Group at sig@samtec.com for more information.

In this report, propagation delay is defined as the signal propagation time through the connector and connector footprint. It includes 4.895 mm for ERM8_EM2 and 1.465 mm for ERF8 PCB trace. Delay is measured at 100 picoseconds signal risetime. Delay is calculated as the difference in time measured between the 50% amplitude levels of the input and output pulses.

Crosstalk or coupled noise data is provided for various signal configurations. All measurements are single disturber. Crosstalk is calculated as a ratio of the input line voltage to the coupled line voltage. The input line is sometimes described as the active or drive line. The coupled line is sometimes described as the quiet or victim line. Crosstalk ratio is tabulated in this report as a percentage. Measurements are made at both the near-end and far-end of the SUT.

As a rule of thumb, 10% crosstalk levels are often used as a general first pass limit for determining acceptable interconnect performance. But modern system crosstalk tolerance can vary greatly. For advice on connector suitability for specific applications, please contact our Signal Integrity Group at sig@samtec.com.

Additional information concerning test conditions and procedures is located in the appendices of this report. Further information may be obtained by contacting our Signal Integrity Group at sig@samtec.com.

Series: ERM8_EM / ERF8

Description: 0.80 mm Edge Rate® Rugged High-Speed Interconnect,
Edge-Mount Terminal mating to Vertical Socket

Appendix A – Frequency Domain Responses

Differential Application – Insertion Loss

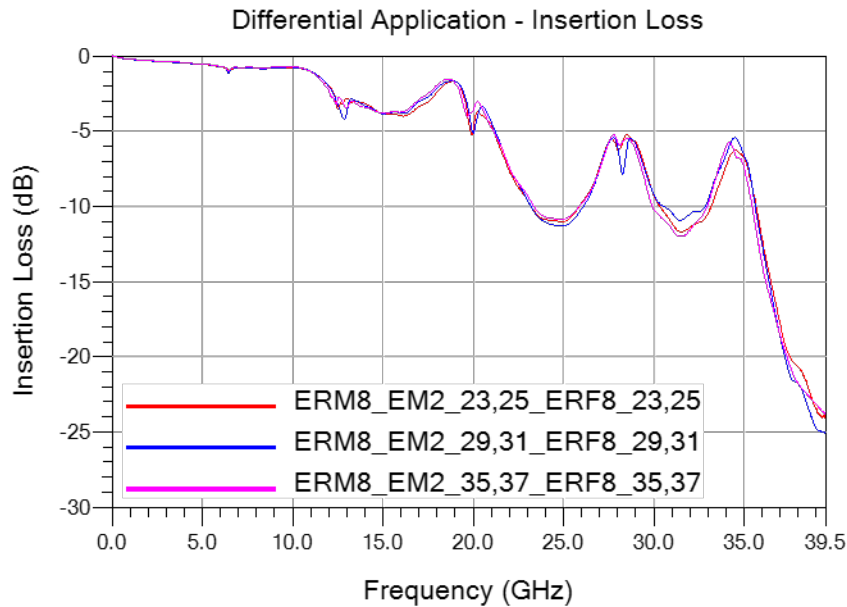

Figure 3

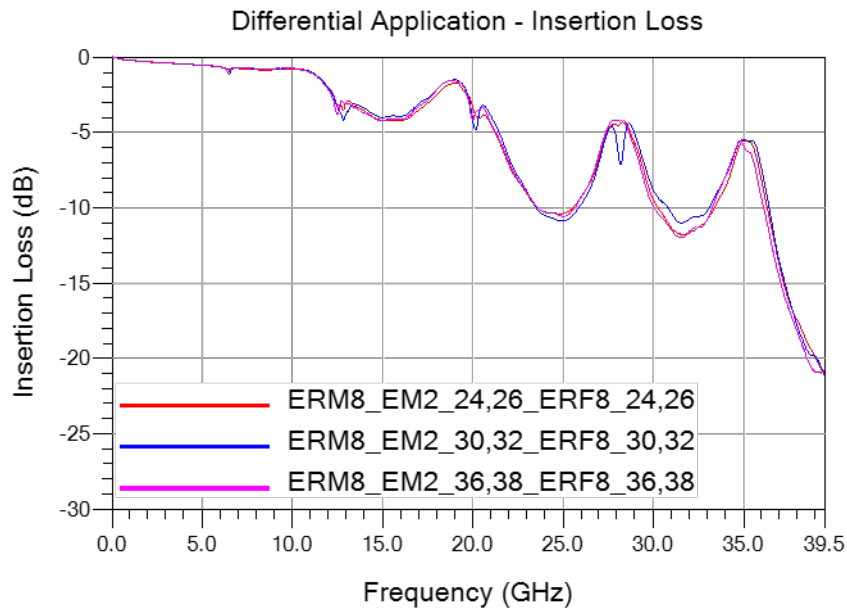

Figure 4

Series: ERM8_EM / ERF8

Description: 0.80 mm Edge Rate® Rugged High-Speed Interconnect,
Edge-Mount Terminal mating to Vertical Socket

Differential Application – Return Loss

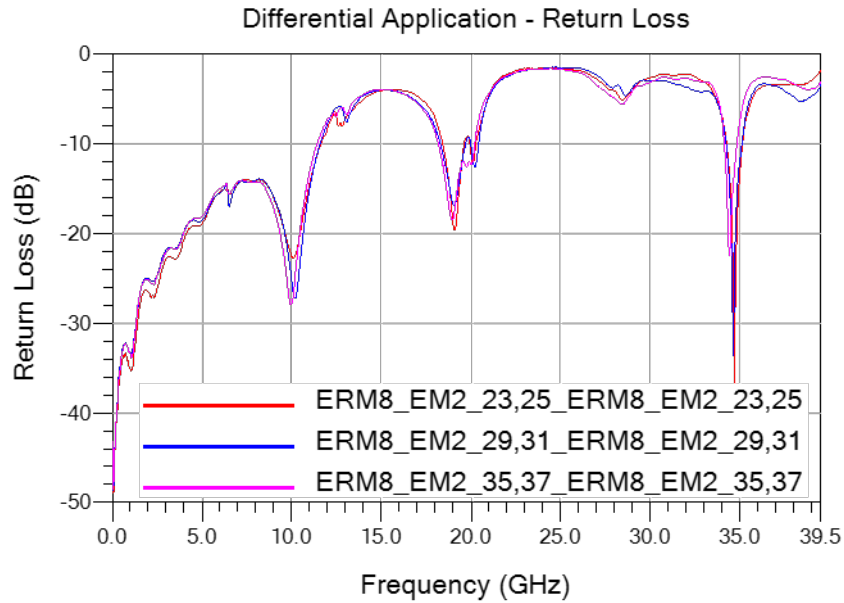

Figure 5

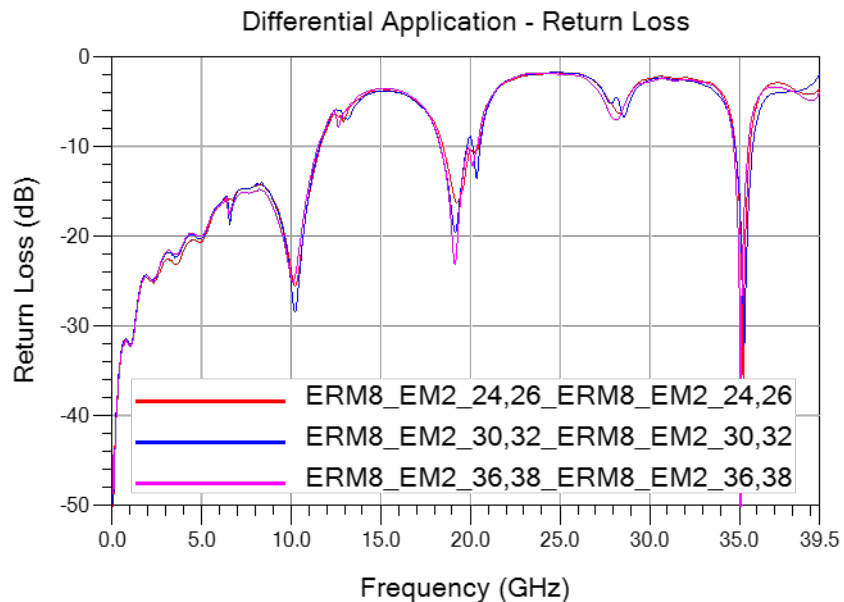

Figure 6

Series: ERM8_EM / ERF8

Description: 0.80 mm Edge Rate® Rugged High-Speed Interconnect,
Edge-Mount Terminal mating to Vertical Socket

Differential Application – NEXT Configurations

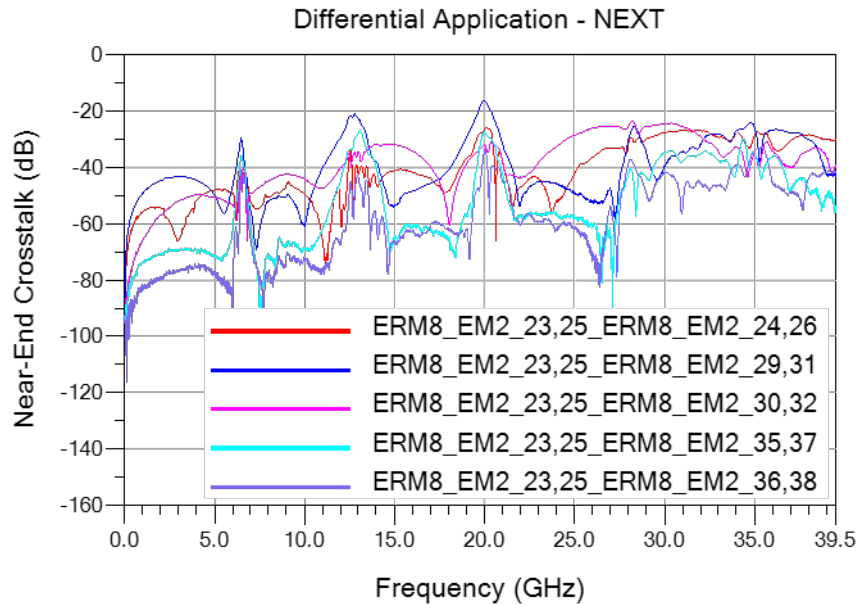

Figure 7

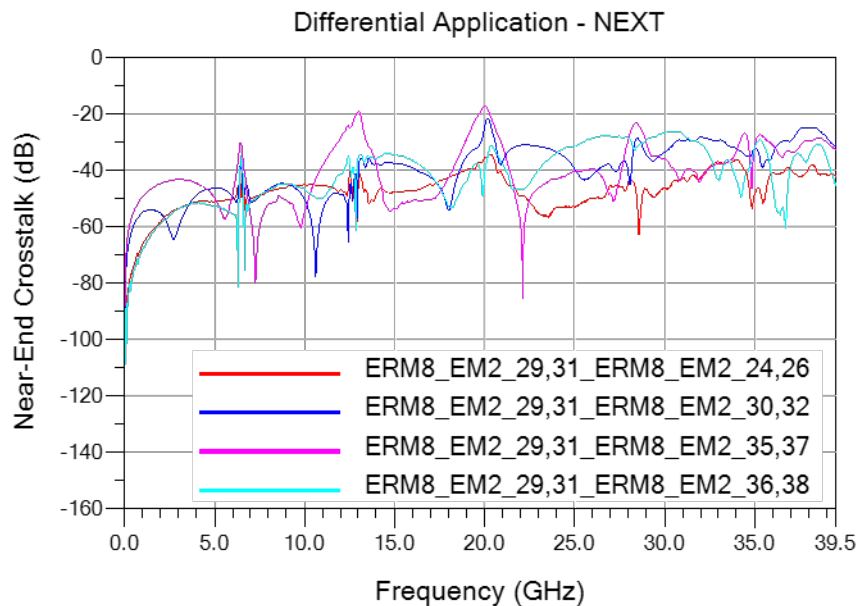

Figure 8

Series: ERM8_EM / ERF8

Description: 0.80 mm Edge Rate® Rugged High-Speed Interconnect,
Edge-Mount Terminal mating to Vertical Socket

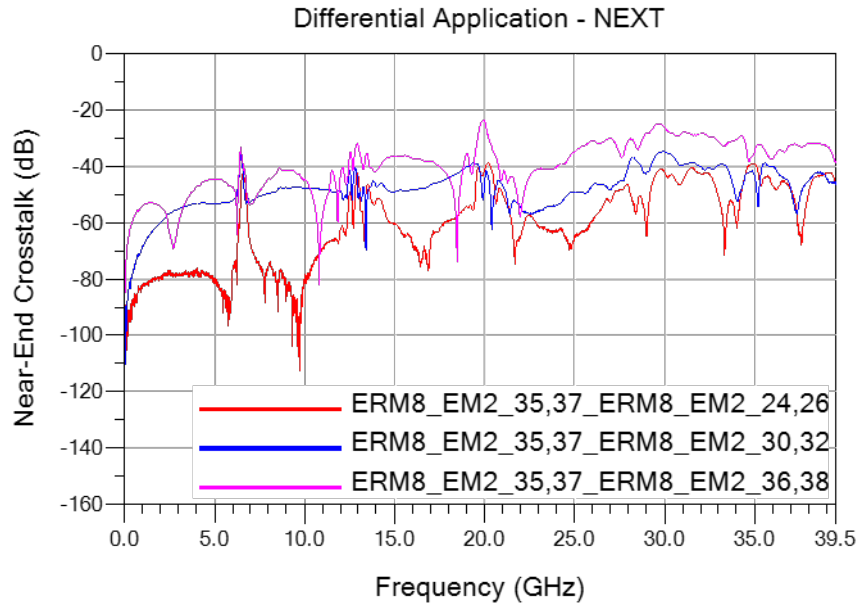

Figure 9

Differential Application – FEXT Configurations

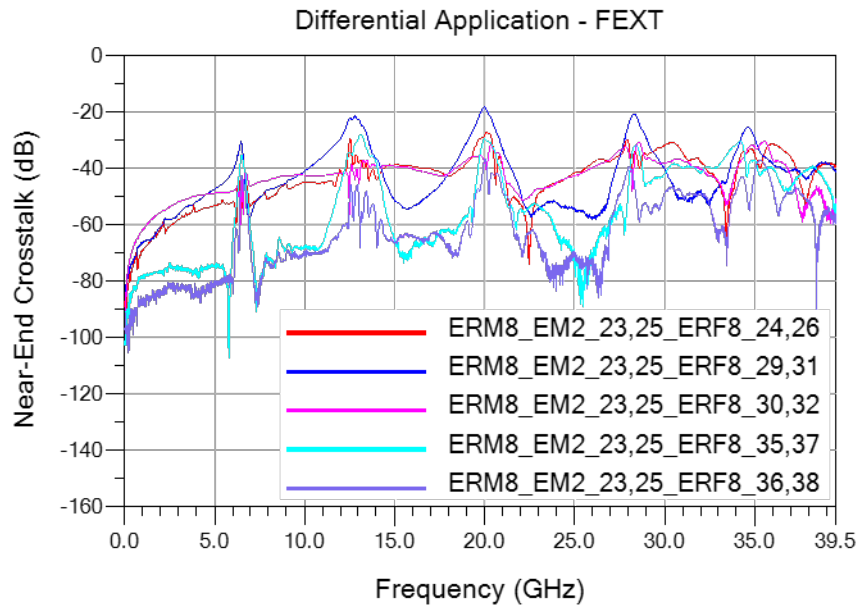

Figure 10

Series: ERM8_EM / ERF8

Description: 0.80 mm Edge Rate® Rugged High-Speed Interconnect,
Edge-Mount Terminal mating to Vertical Socket

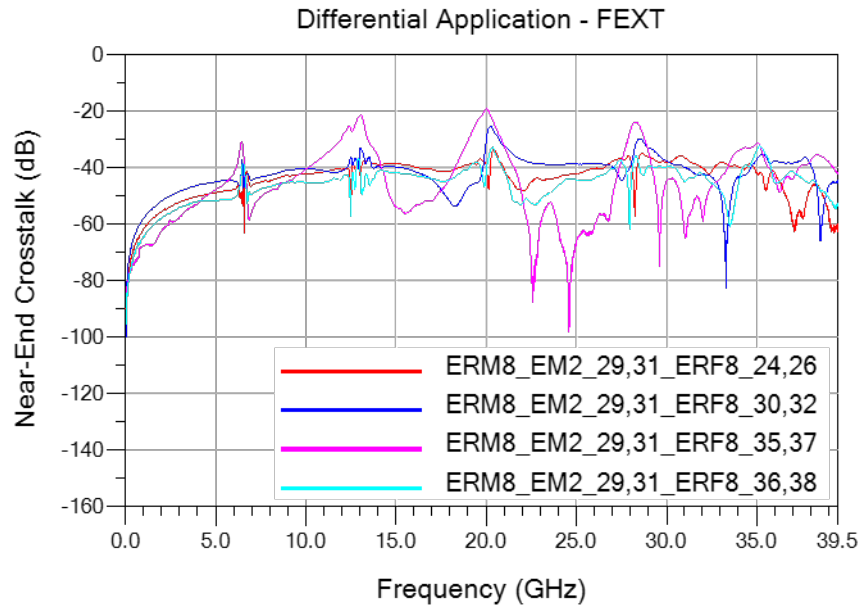

Figure 11

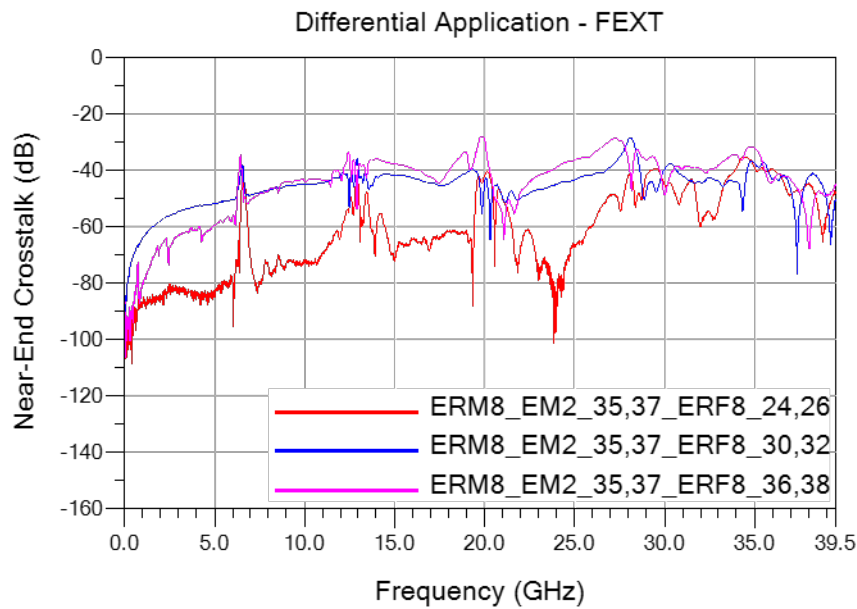

Figure 12

Series: ERM8_EM / ERF8

Description: 0.80 mm Edge Rate® Rugged High-Speed Interconnect,
Edge-Mount Terminal mating to Vertical Socket

Appendix B – Time Domain Responses

Differential Application – Impedance

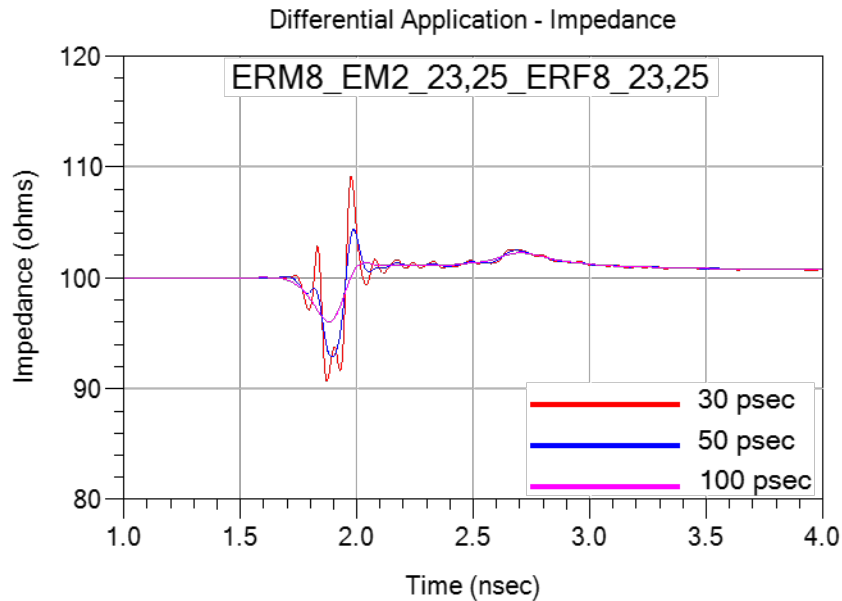

Figure 13

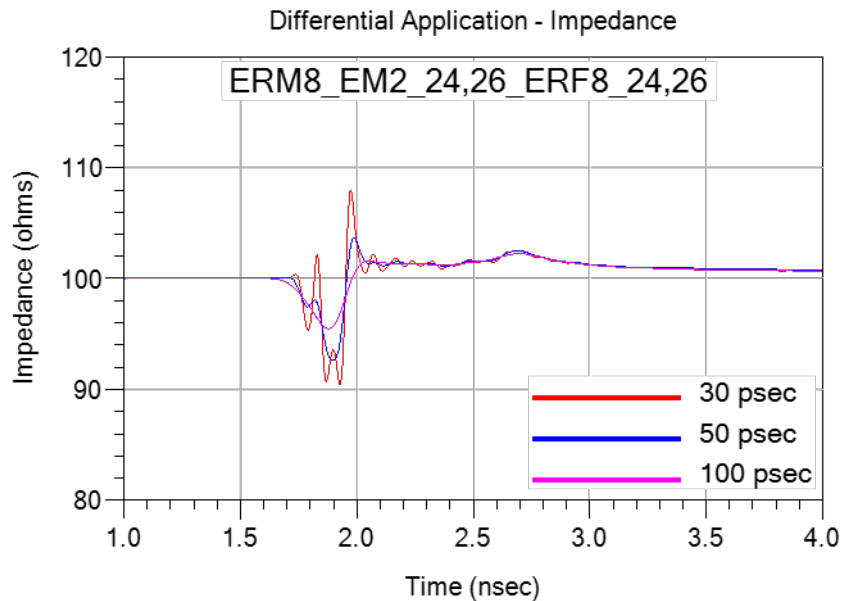

Figure 14

Series: ERM8_EM / ERF8

Description: 0.80 mm Edge Rate® Rugged High-Speed Interconnect,
Edge-Mount Terminal mating to Vertical Socket

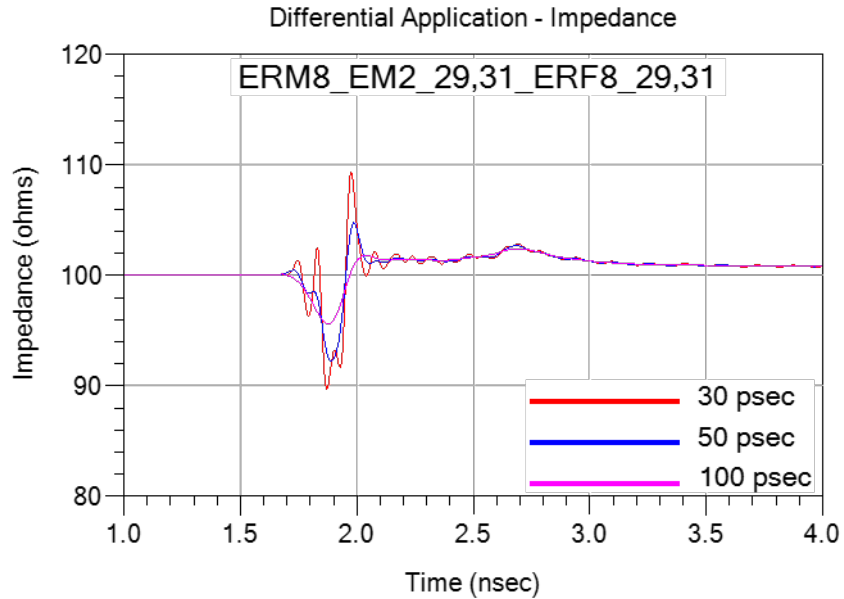

Figure 15

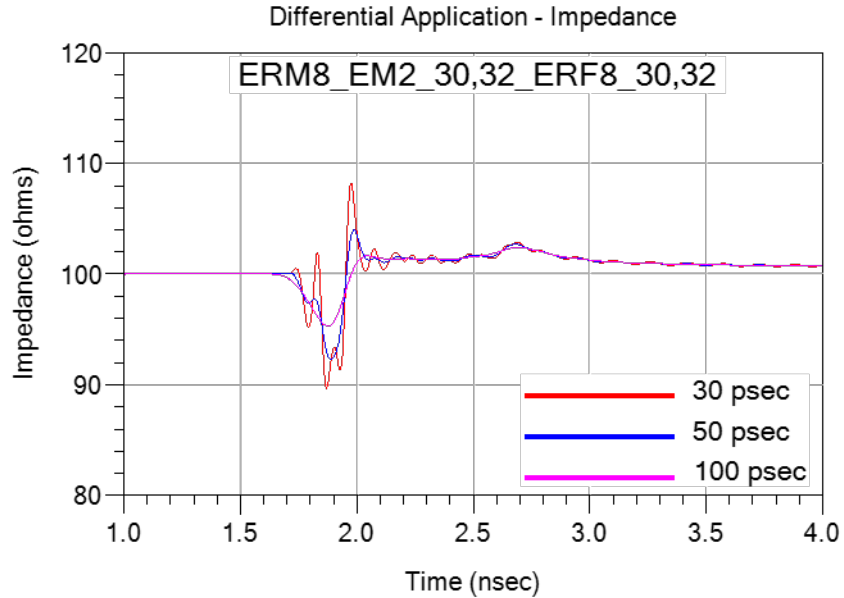

Figure 16

Series: ERM8_EM / ERF8

Description: 0.80 mm Edge Rate® Rugged High-Speed Interconnect,
Edge-Mount Terminal mating to Vertical Socket

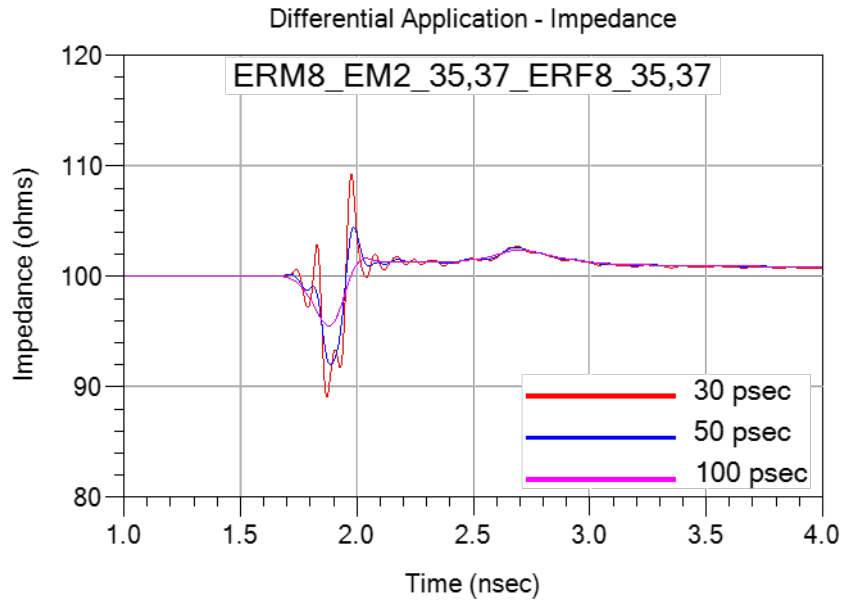

Figure 17

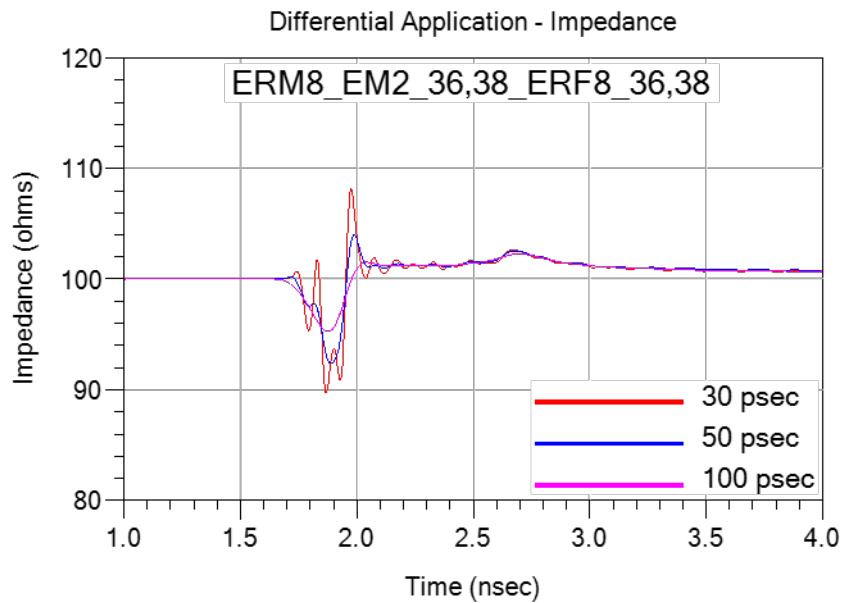

Figure 18

Series: ERM8_EM / ERF8

Description: 0.80 mm Edge Rate® Rugged High-Speed Interconnect,
Edge-Mount Terminal mating to Vertical Socket

Differential Application – Propagation Delay

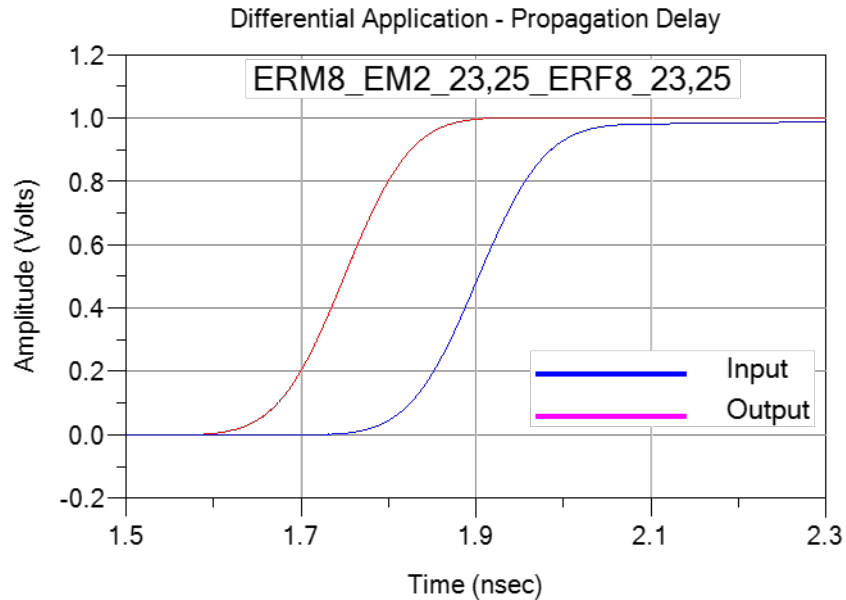

Figure 19

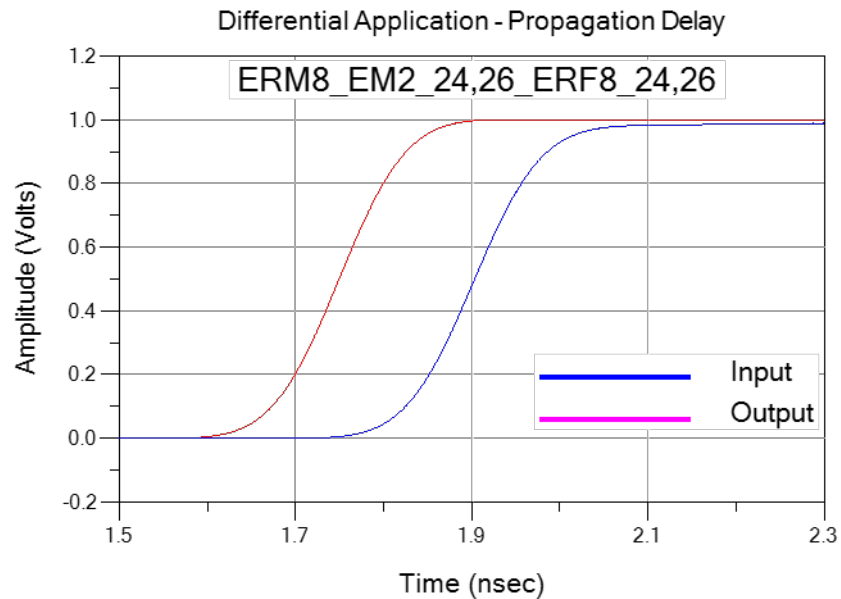

Figure 20

Series: ERM8_EM / ERF8

Description: 0.80 mm Edge Rate® Rugged High-Speed Interconnect,
Edge-Mount Terminal mating to Vertical Socket

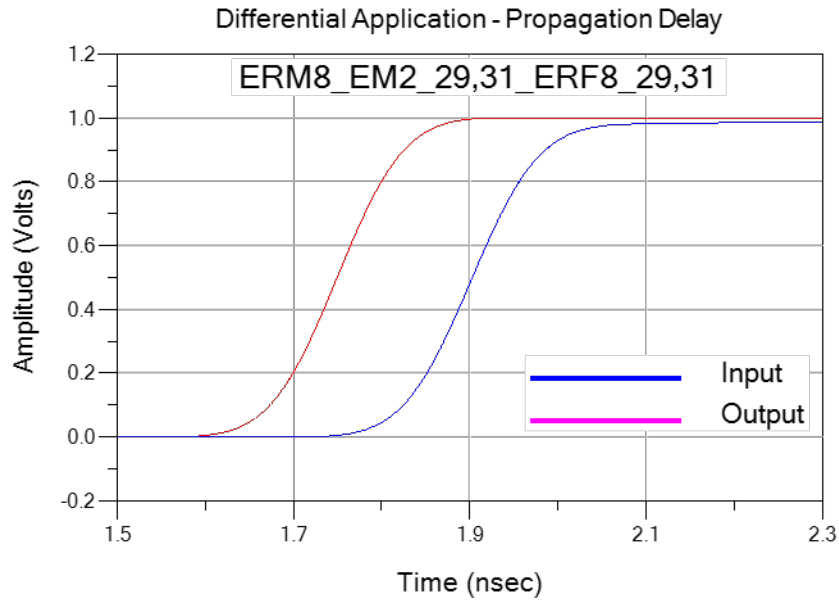

Figure 21

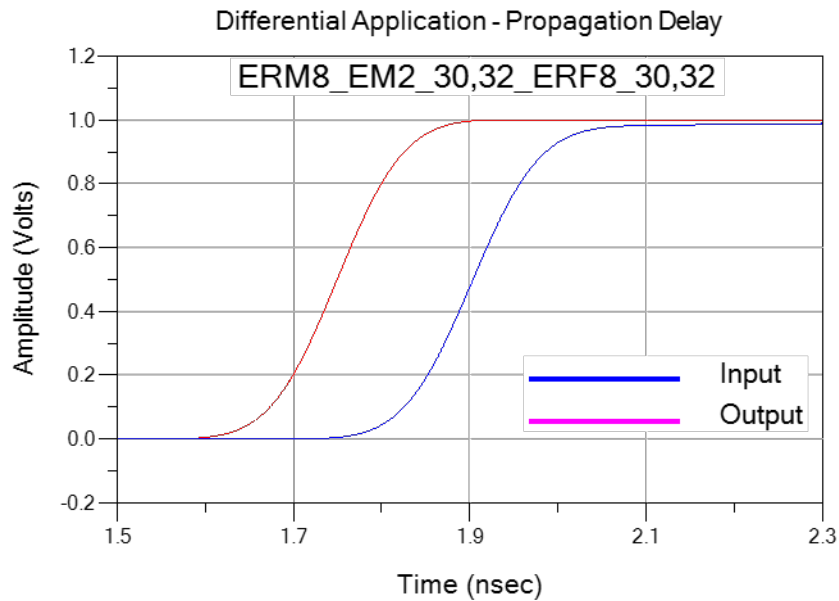

Figure 22

Series: ERM8_EM / ERF8

Description: 0.80 mm Edge Rate® Rugged High-Speed Interconnect,
Edge-Mount Terminal mating to Vertical Socket

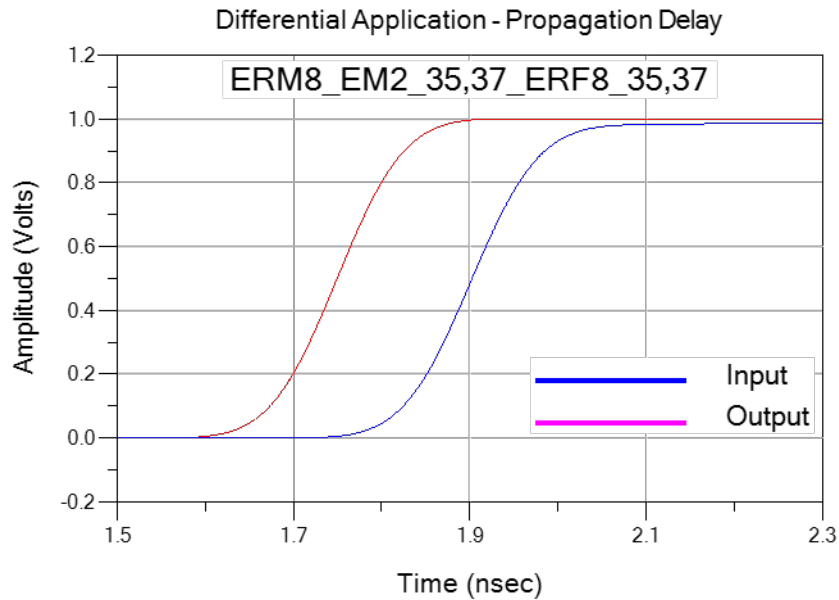

Figure 23

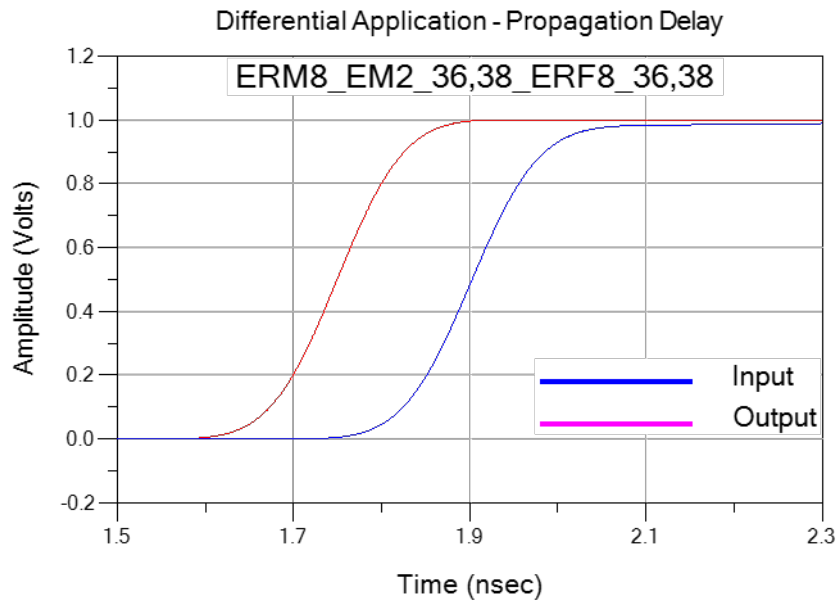

Figure 24

Series: ERM8_EM / ERF8

Description: 0.80 mm Edge Rate® Rugged High-Speed Interconnect,
Edge-Mount Terminal mating to Vertical Socket

Appendix C – Product and Test System Descriptions

Product Description

Product test samples are ERx8 Series connectors. The part number is ERM8-030-01-L-D-EM2 and ERF8-030-05.0-L-DV. A photo of the test articles mounted to SI test boards is shown below.

Test System Description

The test fixtures are composed of six-layer MT40 material with 50Ω signal trace and pad configurations designed for the electrical characterization of Samtec high speed connector products. A PCB mount 2.92mm connector is used to interface the PNA test cables to the test fixtures. Optimization of the 2.92mm launch was performed using full wave simulation tools to minimize reflections. The test fixtures and calibration kit are specific to the ERx8 series connector set and identified by part number PCB-ERM8EM-111332-SIG-0 and PCB-ERF8DV-111332-SIG-0.

PCB-ERM8EM-111332-SIG-0 and PCB-ERF8DV-111332-SIG-0 Test Fixtures

Shown below is photograph of the test board set.

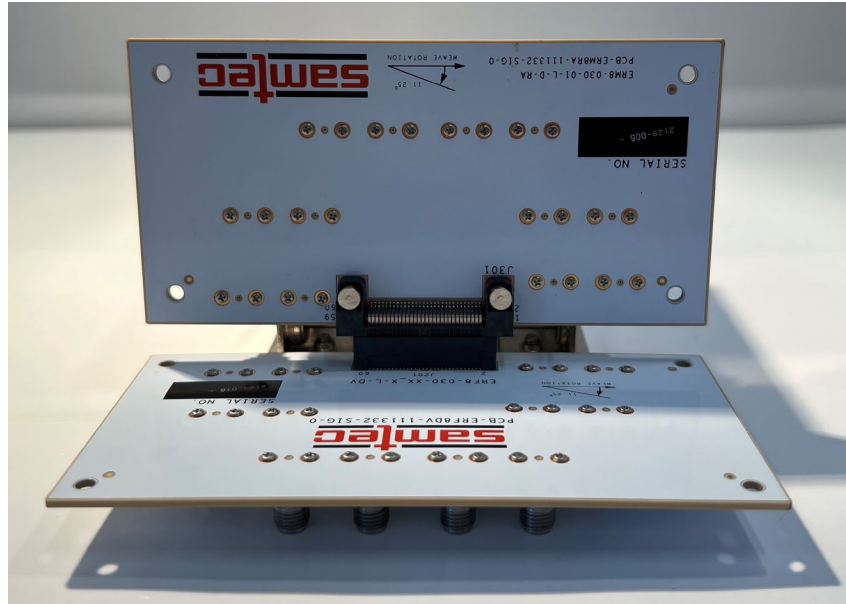

Figure 25

Series: ERM8_EM / ERF8

Description: 0.80 mm Edge Rate® Rugged High-Speed Interconnect,
Edge-Mount Terminal mating to Vertical Socket

PCB Fixtures

The test fixtures used are as follows:

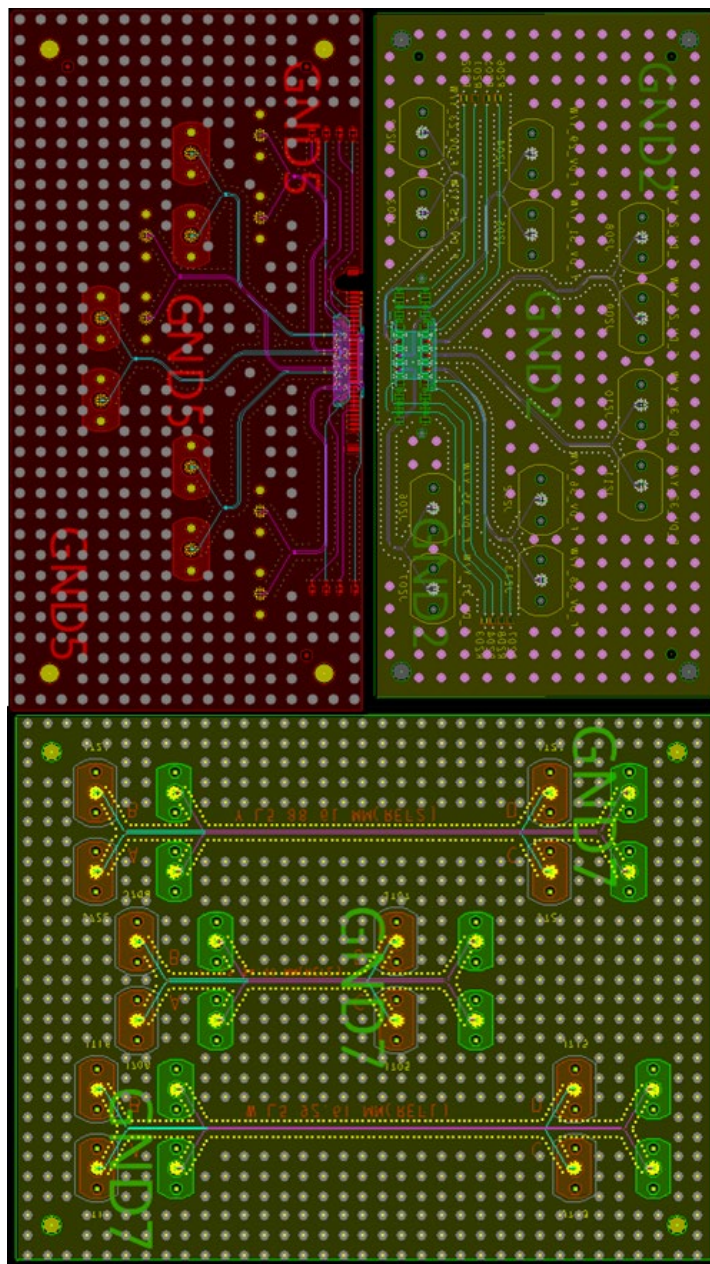

Figure 26

Series: ERM8_EM / ERF8

Description: 0.80 mm Edge Rate® Rugged High-Speed Interconnect,
Edge-Mount Terminal mating to Vertical Socket

All traces on the test boards are length matched to 51.2mm for ERM8_EM2 and 47.77 mm for ERF8 measured from the edge of the pad to the 2.92mm connector. The AFR calibration effectively removes 46.305 mm of test board trace effects. This means that 4.895 mm for ERM8_EM2 and 1.465 mm for ERF8 of test board trace length effects are included in the measurement. The S-Parameter measurement includes:

- A- The ERx8 Series connector set
- B- Test board vias, pads (footprint effects) for the ERM8_EM2 connector side.
- C- 4.895 mm of 0.142 mm wide stripline trace
- D- Test board vias, pads (footprint effects) for the ERF8 connector side.
- E- 1.465 mm of 0.142 mm wide stripline trace

The figure below shows the location of the measurement reference plane.

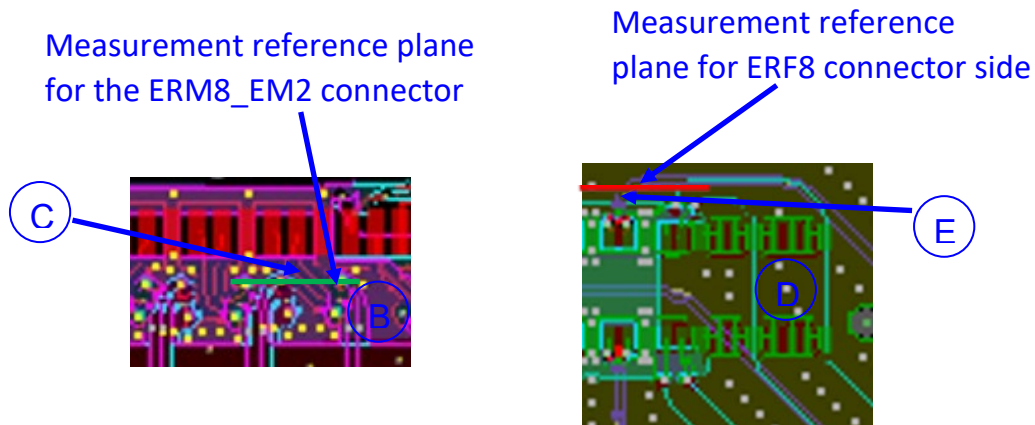

Figure 27

Series: ERM8_EM / ERF8

Description: 0.80 mm Edge Rate® Rugged High-Speed Interconnect,
Edge-Mount Terminal mating to Vertical Socket

Appendix D – Test and Measurement Setup

For frequency domain measurements, the test instrument is the Keysight N5225B PNA-L network analyzer. Frequency domain data are obtained directly from the instrument and figures are generated by Keysight ADS. The network analyzer is configured as follows:

Start Frequency – 10 MHz
Stop Frequency – 40 GHz
Number of points – 4000
IFBW – 1 KHz

N5225B Measurement Setup

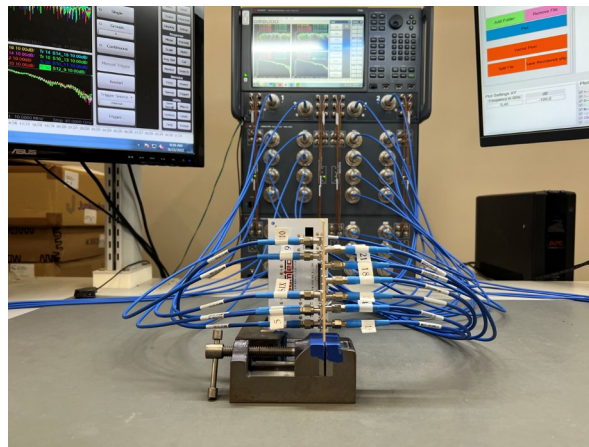

Figure 28

Test Instruments

<u>QTY</u>	<u>Description</u>
1	Keysight N5225B PNA Network Analyzer (10 MHz to 40 GHz)
1	Keysight 1.85mm E-Cal N4694-60003 (10 MHz to 40 GHz)

Test Cables & Adapters

<u>QTY</u>	<u>Description</u>
4	1m Junkosha 2.4mm male to female cables

Series: ERM8_EM / ERF8

Description: 0.80 mm Edge Rate® Rugged High-Speed Interconnect,
Edge-Mount Terminal mating to Vertical Socket

Appendix E - Frequency and Time Domain Measurements

Frequency (S-Parameter) Domain Procedures

The quality of any data taken with a network analyzer is directly related to the quality of the calibration standards and the use of proper test procedures. For this reason, extreme care is taken in the design of the through calibration standards, the SI test boards, and the selection of the PCB vendor.

A coaxial SOLT calibration is performed using N4694-60003 E-Cal module. Then DUT measurements are performed under SOLT calibration. The measurements include the effect of test fixture. The measurements of the 2X THRU line standards are required to remove the test fixture effect.

Time Domain Procedures

Mathematically, Frequency Domain data can be transformed to obtain a Time Domain response. Perfect transformation requires Frequency Domain data from DC to infinity Hz. Fortunately, a very accurate Time Domain response can be obtained with bandwidth-limited data, such as measured with modern network analyzer.

The Time Domain responses were generated using Keysight ADS 2021. This tool has a transient convolution simulator, which can generate a Time Domain response directly from measured S-Parameters. An example of a similar methodology is provided in the Samtec Technical Note on domain transformation.

[http://www.samtec.com/Technical_Library/reference/articles/pdfs/tech-note_using-PLTS-for-time-domain-data_web.pdf](http://www.samtec.com/Technical_Library/reference/articles/pdfs/tech-note_using_PLTS-for-time-domain-data_web.pdf)

Impedance (TDR)

A step pulse is applied to the touchstone model of the connector and the reflected voltage is monitored. The reflected voltage is converted to a reflection coefficient and then transformed into an impedance profile. All ports of the Touchstone model are terminated in 50 ohms.

Propagation Delay (TDT)

The Propagation Delay is a measure of the Time Domain delay through the connector and footprint. A step pulse is applied to the touchstone model of the connector and the transmitted voltage is monitored. The same pulse is also applied to a reference channel with zero loss, and the Time Domain pulses are plotted on the same graph. The difference in time, measured at the 50% point of the step voltage is the propagation delay.

Series: ERM8_EM / ERF8

Description: 0.80 mm Edge Rate® Rugged High-Speed Interconnect,
Edge-Mount Terminal mating to Vertical Socket

Appendix F – Glossary of Terms

ADS – Advanced Design Systems

FD – Frequency domain

FEXT – Far-End Crosstalk

GSG – Ground–Signal–Ground; geometric configuration

GSSG - Ground–Signal–Signal–Ground; geometric configuration

NEXT – Near-End Crosstalk

PCB – Printed Circuit Board

SE – Single-Ended

SI – Signal Integrity

SOLT – acronym used to define Short, Open, Load & Thru Calibration Standards

TD – Time Domain

TDA – Time Domain Analysis

TDR – Time Domain Reflectometry

TDT – Time Domain Transmission

Z – Impedance (expressed in ohms)