

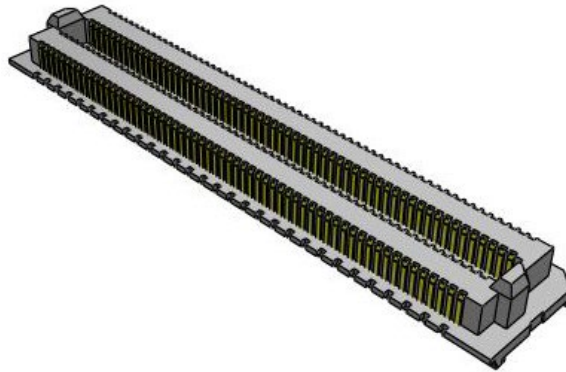

---

## Analog Characterization Report

**APM6-060-01.5-S-04-2-A-XR**



mated with

**APF6-060-03.5-S-04-2-A-XR**

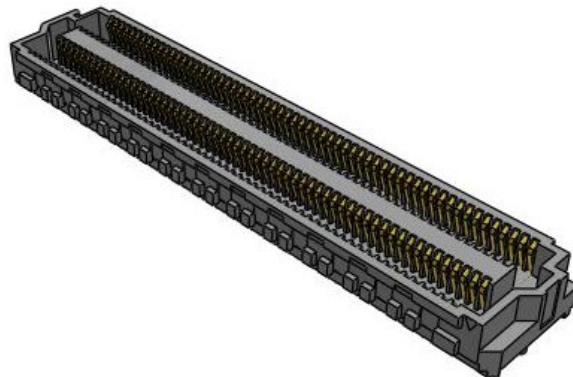

### Description:

**0.635 mm Pitch AcceleRate® HP High-Performance Array Connector,  
5 mm Stack Height, Differential RF Analog Application**

**Series:** APM6/APF6

**Description:** 0.635 mm pitch AcceleRate® HP High-Performance Array, 5 mm Stack Height,  
Differential RF Analog Application

## Table of Contents

Connector Overview .....	1
Characterization Details .....	1
Differential and Single-Ended Data .....	1
Connector Signal to Ground Ratio .....	1
Frequency Domain Data .....	3
Time Domain Data .....	3
Appendix A – Frequency Domain Responses .....	4
Differential Application – NEXT Configurations .....	4
Differential Application – FEXT Configurations .....	5
Differential Application – PS NEXT Configurations .....	6
Differential Application – PS FEXT Configurations .....	7
Table 1 - Differential Crosstalk (dB) .....	8
Differential Application – Return Loss .....	9
Differential Application – VSWR .....	9
Differential Application – Insertion Loss .....	10
Table 2 – Differential Propagation Delay (Mated Connector) .....	10
Appendix B – Product and Test System Descriptions .....	11
Product Description .....	11
Test System Description .....	11
PCB-113655-SIG-XX Test Fixtures .....	11
PCB Fixtures .....	12
Appendix C – Test and Measurement Setup .....	14
N5225B Measurement Setup .....	14
Test Instruments .....	14
Test Cables & Adapters .....	14
Appendix D - Frequency and Time Domain Measurements .....	15
Frequency (S-Parameter) Domain Procedures .....	15
Appendix E – Glossary of Terms .....	15

**Series:** APM6/APF6

**Description:** 0.635 mm pitch AcceleRate® HP High-Performance Array, 5 mm Stack Height, Differential RF Analog Application

## Connector Overview

These 0.635 mm pitch arrays feature extreme performance to 112 Gbps PAM4 and an open-pin-field design for grounding and routing flexibility. This cost-optimized solution features up to 800 total pins (roadmap to 1,000+) in a low 5 mm stack height (and up to 10 mm). AcceleRate® is available in 4 row open pin field arrays, pins per row selections are 20, 40, 60 or 100. This report reflects electrical characteristics specific to a mated APM6/APF6 5 mm stack height for Differential RF Analog solutions.

## Characterization Details

This report presents data that characterizes the signal integrity response of a connector pair in a controlled printed circuit board (PCB) environment. All efforts are made to reveal typical best-case responses inherent to the system under test (SUT).

In this report, the SUT includes the connector pair and footprint effects on a typical multi-layer PCB. PCB effects (trace loss) are de-embedded from test data. Board-related effects, such as pad-to-ground capacitance, are included in the data presented in this report.

Additionally, intermediate test signal connections can mask the connector's true performance. Such connection effects are minimized by using high performance test cables and adapters. Where appropriate, calibration and de-embedding routines are also used to reduce residual effects.

## Differential and Single-Ended Data

Most Samtec connectors can be used successfully in both differential and single-ended applications. However, electrical performance will differ depending on the signal drive type. In this report, data is presented for differentially driven scenarios.

## Connector Signal to Ground Ratio

Samtec connectors are most often designed for generic applications and can be implemented using various signal and ground pin assignments. In high isolation systems, provisions must be made in the interconnect for signal return currents. Such paths are often referred to as "ground." In some connectors, a ground plane or blade, or an outer shield, is used as the signal return, while in others, connector pins are used as signal returns. Various combinations of signal pins, ground blades, and shields can also be utilized. Electrical performance can vary significantly depending upon the number and location of ground pins and terminal pins.

**Series:** APM6/APF6

**Description:** 0.635 mm pitch AcceleRate® HP High-Performance Array, 5 mm Stack Height, Differential RF Analog Application

In general, the more pins dedicated to ground, the better electrical performance will be. But dedicating pins to ground reduces signal density of a connector. Therefore, care must be taken when choosing signal/ground ratios in cost or density-sensitive applications.

For this connector, the following configurations were evaluated:

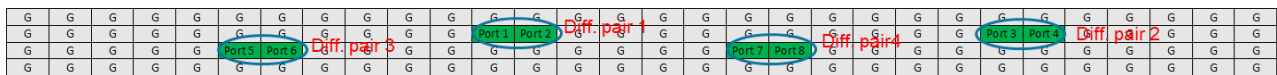
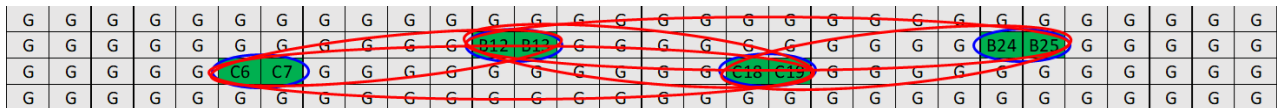

APM6

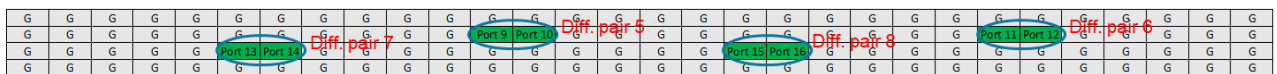

APF6

Differential pairs (denoted by blue circles):

- GGGGSSGGGG (Ground\*5-positive Signal-negative Signal-Ground\*5)

Differential Crosstalk (denoted by red circles):

- In row: from the terminals to the other terminals on the same row.
- Across row: from one row of terminals to the other row of terminals.

In a real system environment, active signals might be located at the outer edges of the signal contacts of concern, as opposed to the ground signals utilized in laboratory testing. For example, in a single-ended system, a pin-out of “SSSS,” or four adjacent single ended signals might be encountered as opposed to the “GSG” and “GSSG” configurations tested in the laboratory. Electrical characteristics in such applications could vary slightly from laboratory results. But in most applications, performance can safely be considered equivalent.

**Series:** APM6/APF6

**Description:** 0.635 mm pitch AcceleRate® HP High-Performance Array, 5 mm Stack Height, Differential RF Analog Application

### Frequency Domain Data

Frequency Domain parameters are helpful in evaluating the connector system's signal loss and crosstalk characteristics across a range of sinusoidal frequencies. In this report, parameters presented in the Frequency Domain are Near-End and Far End Crosstalk, Power Sum Near- End Crosstalk, Power Sum Far- End Crosstalk, Insertion Loss, Return Loss, VSWR (Voltage Standing Wave Ratio). Other parameters or formats, from S-Parameters may be available upon request. Please contact our Signal Integrity Group at [sig@samtec.com](mailto:sig@samtec.com) for more information.

Frequency performance characteristics for the SUT are generated directly from network analyzer measurements.

### Time Domain Data

Time Domain parameters indicate Impedance mismatch versus length, signal propagation time, and crosstalk in a pulsed signal environment. The measured S-Parameters from the network analyzer are post-processed using Keysight Advanced Design System to obtain the time domain response. Time Domain procedure is provided in Appendix D of this report. Parameters or formats not included in this report may be available upon request. Please contact our Signal Integrity Group at [sig@samtec.com](mailto:sig@samtec.com) for more information.

In this report, propagation delay is defined as the signal propagation time through the connector and connector footprint. It includes 0.96 mm of differential PCB trace on both the APM6 and APF6 each. Delay is measured at 100 picoseconds signal risetime. Delay is calculated as the difference in time measured between the 50% amplitude levels of the input and output pulses.

Crosstalk or coupled noise data is provided for various signal configurations. All measurements are single disturber. Crosstalk is calculated as a ratio of the input line voltage to the coupled line voltage. The input line is sometimes described as the active or drive line. The coupled line is sometimes described as the quiet or victim line. Crosstalk ratio is tabulated in this report as a percentage. Measurements are made at both the near-end and far-end of the SUT.

Additional information concerning test conditions and procedures is located in the appendices of this report. Further information may be obtained by contacting our Signal Integrity Group at [sig@samtec.com](mailto:sig@samtec.com).

Series: APM6/APF6

Description: 0.635 mm pitch AcceRate® HP High-Performance Array, 5 mm Stack Height, Differential RF Analog Application

## Appendix A – Frequency Domain Responses

### Differential Application – NEXT Configurations

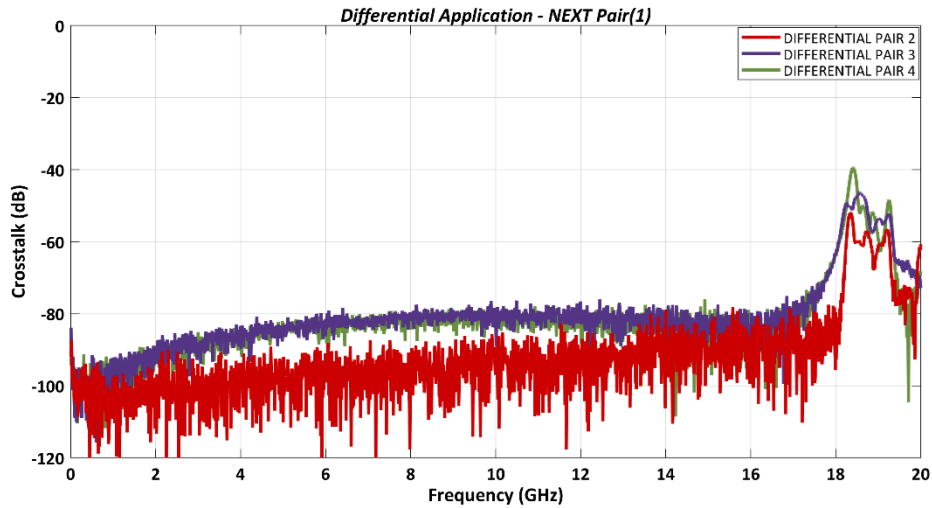

Figure 1

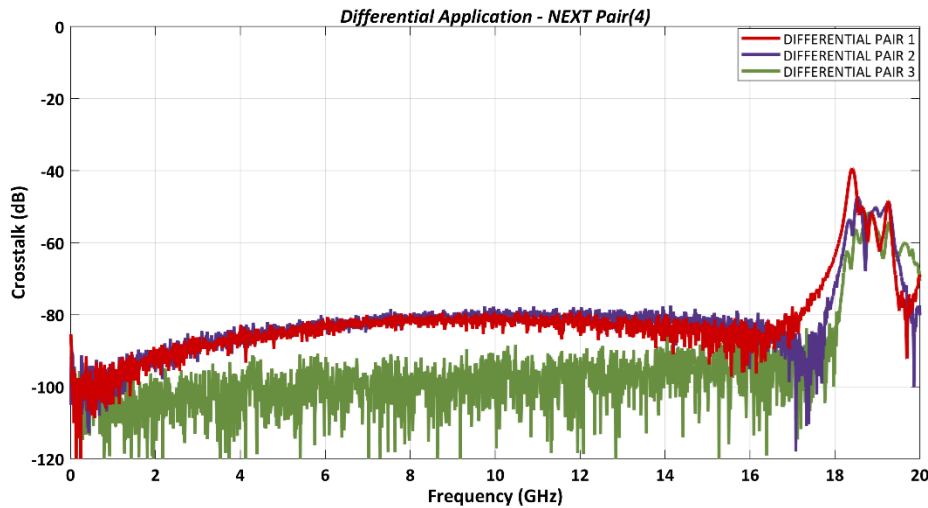

Figure 2

**Series:** APM6/APF6

**Description:** 0.635 mm pitch AcceRate® HP High-Performance Array, 5 mm Stack Height, Differential RF Analog Application

### Differential Application – FEXT Configurations

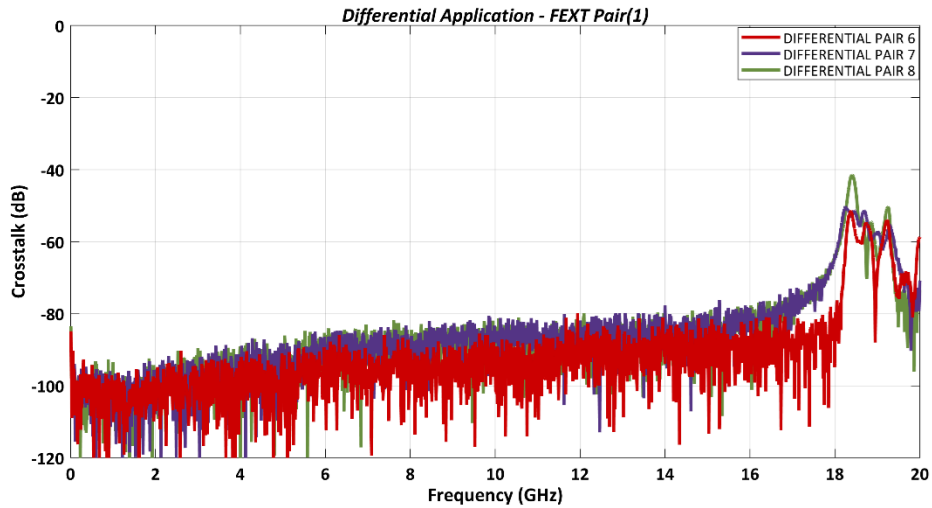

Figure 3

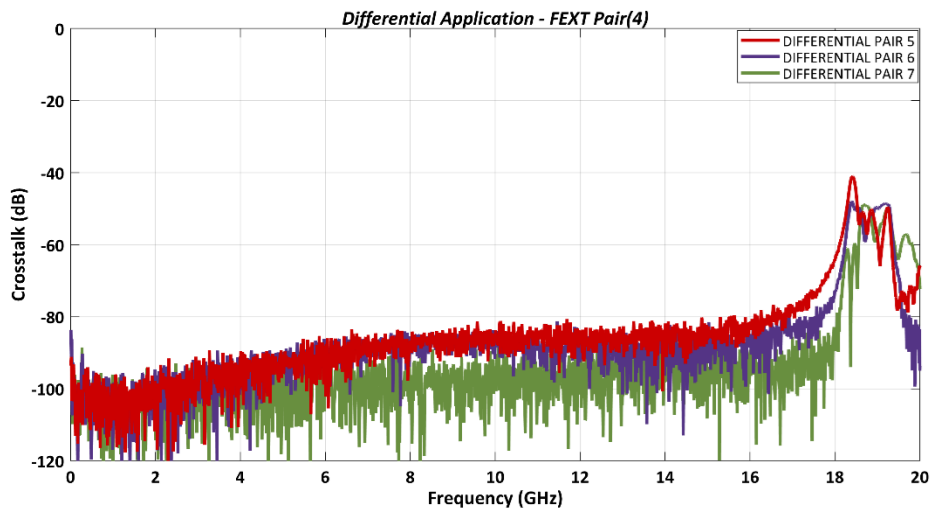

Figure 4

Series: APM6/APF6

Description: 0.635 mm pitch AcceRate® HP High-Performance Array, 5 mm Stack Height, Differential RF Analog Application

### Differential Application – PS NEXT Configurations

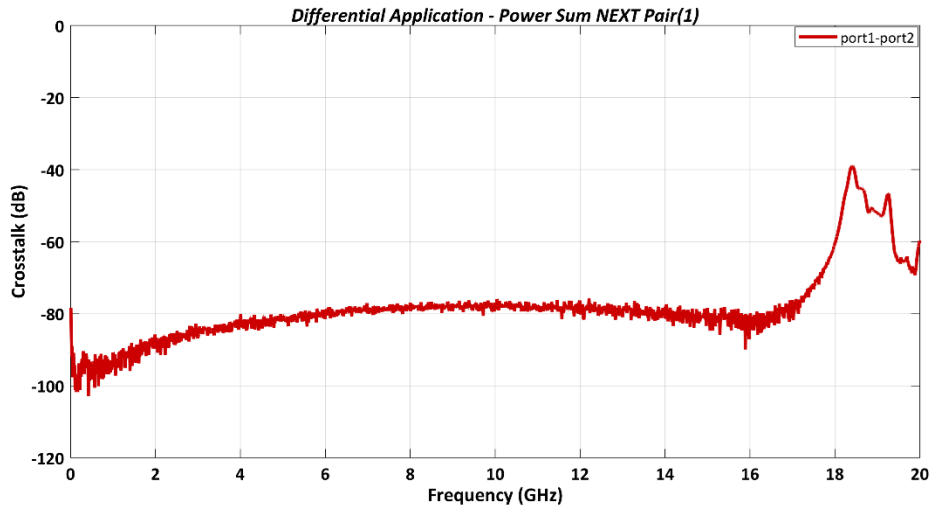

Figure 5

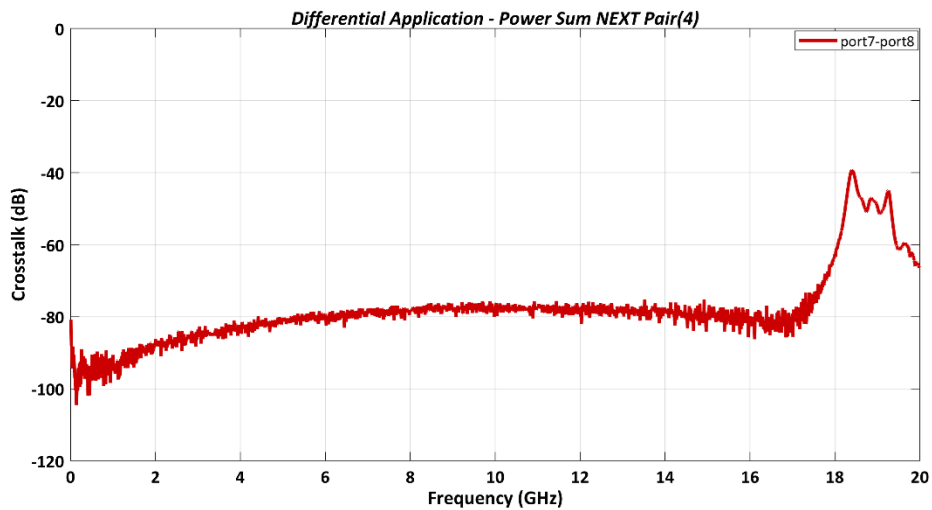

Figure 6

Series: APM6/APF6

Description: 0.635 mm pitch AcceRate® HP High-Performance Array, 5 mm Stack Height, Differential RF Analog Application

### Differential Application – PS FEXT Configurations

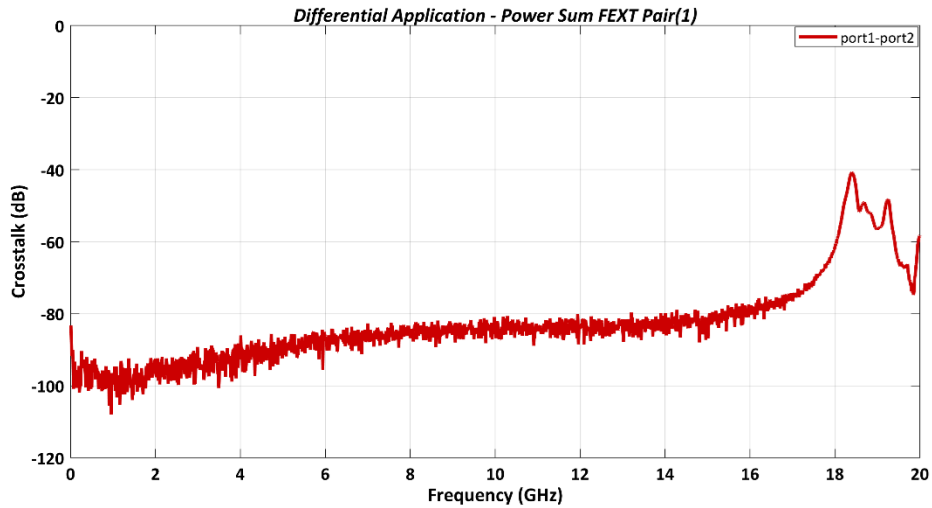

Figure 7

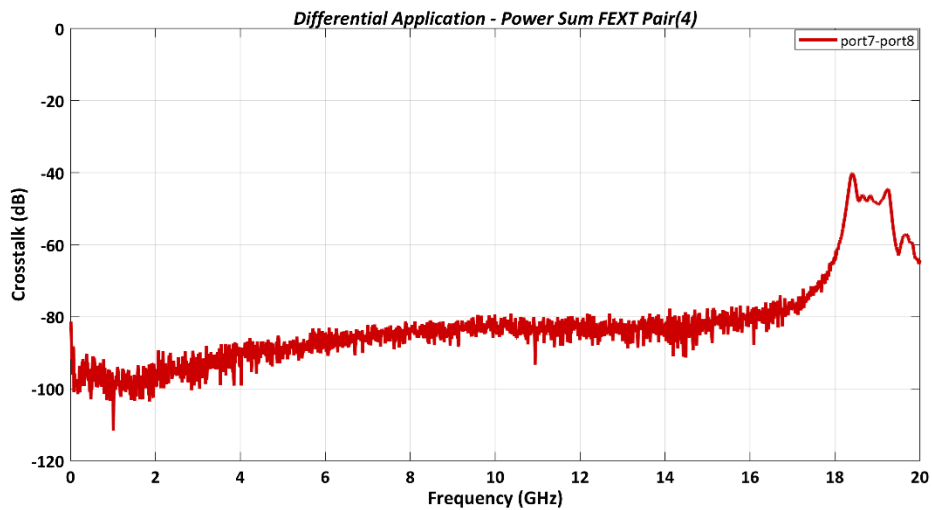

Figure 8

Series: APM6/APF6

Description: 0.635 mm pitch AcceleRate® HP High-Performance Array, 5 mm Stack Height, Differential RF Analog Application

Table 1 - Differential Crosstalk (dB)				
Input(tr)	Driver	Receiver	4GHz	8GHz
NEXT	APM6_PAIR 2	APM6_PAIR 1	-96.79	-101.9
	APM6_PAIR 3	APM6_PAIR 1	-85.38	-81.39
	APM6_PAIR 4	APM6_PAIR 1	-87.68	-84.44
	APM6_PAIR 1	APM6_PAIR 4	-84.27	-79.52
	APM6_PAIR 2	APM6_PAIR 4	-88.25	-81.67
	APM6_PAIR 3	APM6_PAIR 4	-99.92	-103.2
FEXT	APF6_PAIR 6	APM6_PAIR 1	-102.0	-89.82
	APF6_PAIR 7	APM6_PAIR 1	-97.81	-93.66
	APF6_PAIR 8	APM6_PAIR 1	-92.97	-96.86
	APF6_PAIR 5	APM6_PAIR 4	-99.43	-87.19
	APF6_PAIR 6	APM6_PAIR 4	-94.96	-87.93
	APF6_PAIR 7	APM6_PAIR 4	-104.3	-96.73

Series: APM6/APF6

Description: 0.635 mm pitch AcceRate® HP High-Performance Array, 5 mm Stack Height, Differential RF Analog Application

### Differential Application – Return Loss

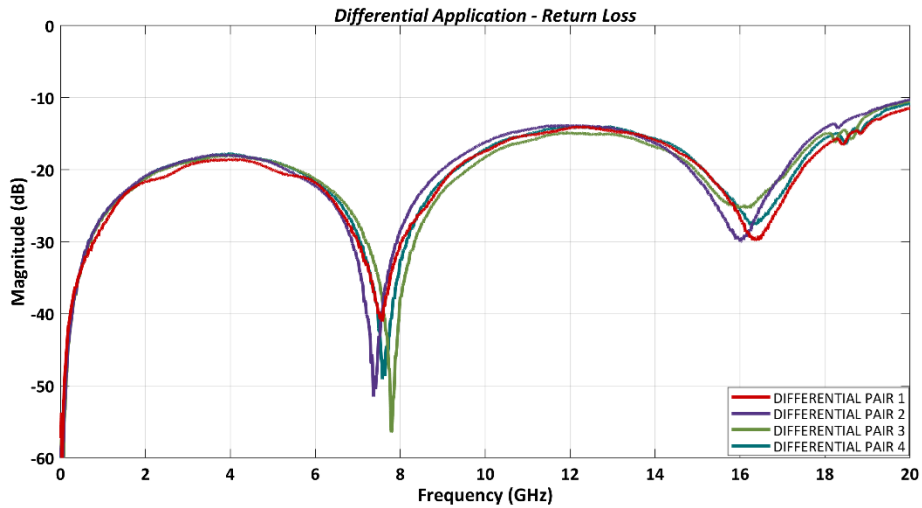

Figure 9

### Differential Application – VSWR

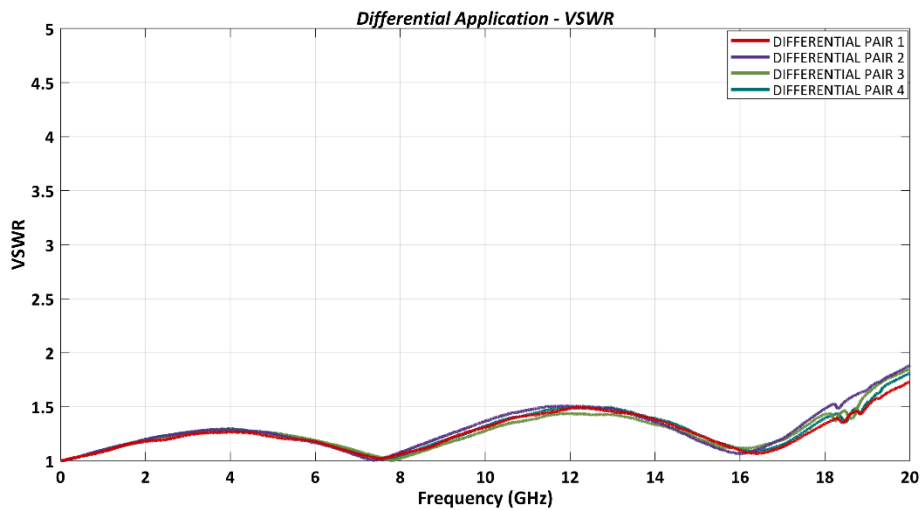

Figure 10

Series: APM6/APF6

Description: 0.635 mm pitch AcceleRate® HP High-Performance Array, 5 mm Stack Height, Differential RF Analog Application

Differential Application – Insertion Loss

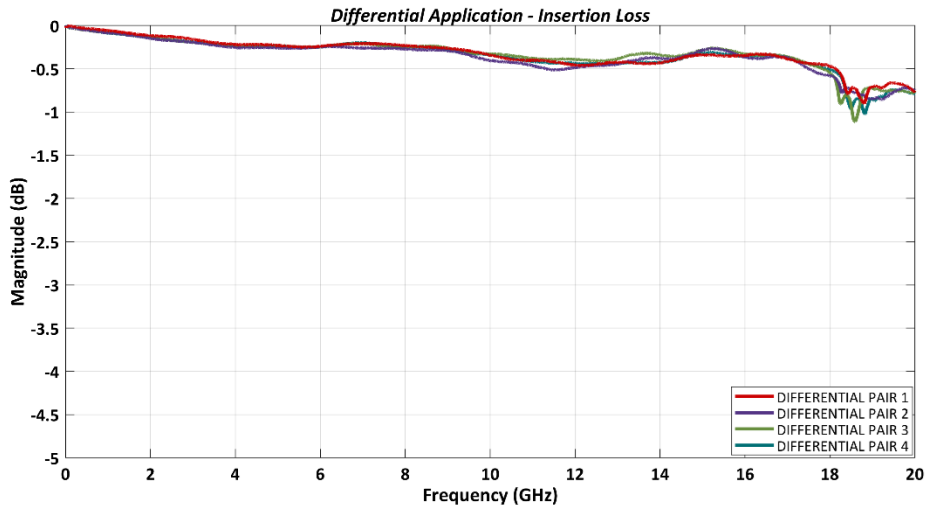

Figure 11

Table 2 – Differential Propagation Delay (Mated Connector)	
PAIR 1	52 ps
PAIR 2	55 ps
PAIR 3	53 ps
PAIR 4	53 ps

**Series:** APM6/APF6

**Description:** 0.635 mm pitch AcceleRate® HP High-Performance Array, 5 mm Stack Height, Differential RF Analog Application

## Appendix B – Product and Test System Descriptions

### Product Description

Product test samples are APM6/APF6 series connectors. The part number is APM6-060-01.5-S-04-2-A-XR and APF6-060-03.5-S-04-2-A-XR. A photo of the test articles mounted to SI test boards is shown below.

### Test System Description

The test fixtures are composed of six-layer I-TERA MT40 materials with 50Ω signal trace and pad configurations designed for the electrical characterization of Samtec high speed connector products. A PCB mount 2.4mm connector is used to interface the PNA test cables to the test fixtures. Optimization of the 2.4mm launch was performed using full wave simulation tools to minimize reflections. The test fixtures and calibration kit are specific to the APM6/APF6 series connector set and identified by part number PCB-113655-SIG-XX.

### PCB-113655-SIG-XX Test Fixtures

Shown below is a photograph of the test board set.

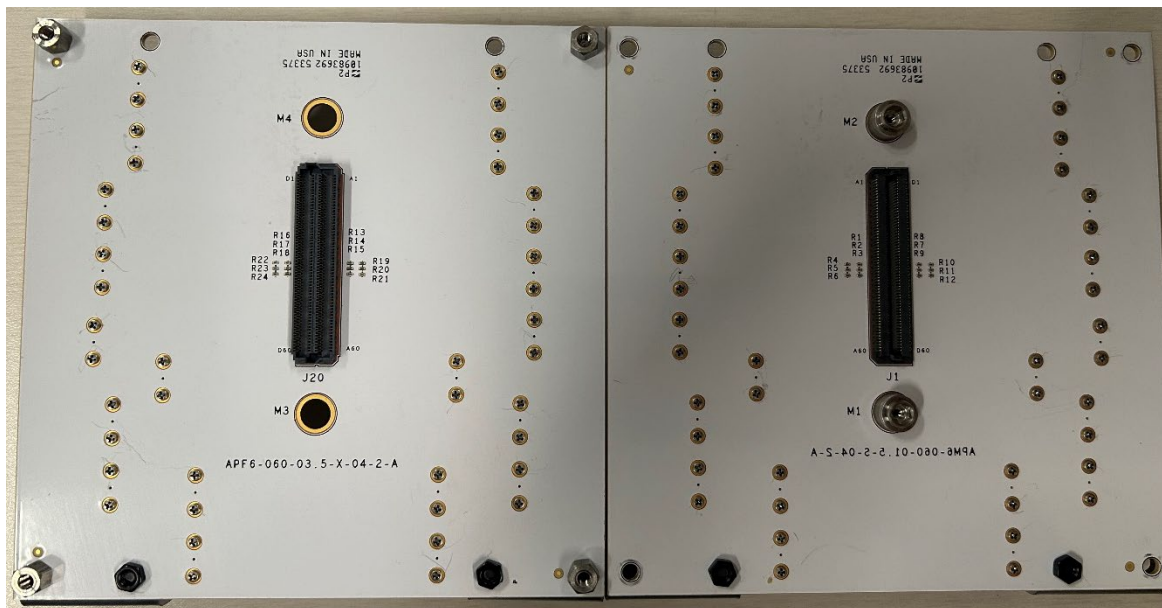

Figure 12

Series: APM6/APF6

Description: 0.635 mm pitch AcceleRate® HP High-Performance Array, 5 mm Stack Height, Differential RF Analog Application

PCB Fixtures

The test fixtures used are as follows:

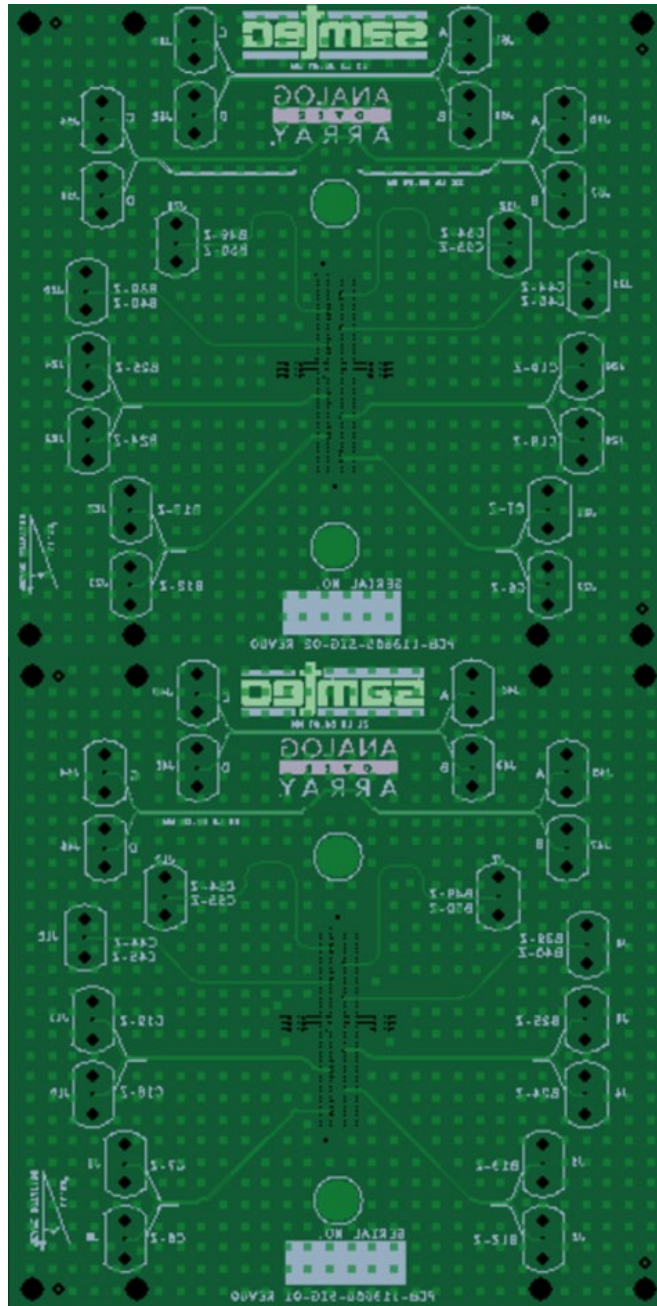

Figure 13

**Series:** APM6/APF6

**Description:** 0.635 mm pitch AcceleRate® HP High-Performance Array, 5 mm Stack Height, Differential RF Analog Application

All traces on the test boards are length matched to 50 mm measured from the edge of the pad to the 2.4mm connector. The AFR calibration effectively removes 49.04 mm of test board trace effects. This means that 0.96 mm of test board trace length effects are included in both sides of test boards in the measurement. The S-Parameter measurement includes:

- A- The APM6/APF6 Series connector set
- B- Test board vias, pads (footprint effects) for the APM6 connector side.
- C- 0.96 mm of 0.162 mm wide microstrip trace.
- D- Test board vias, pads (footprint effects) for the APF6 connector side.
- E- 0.96 mm of 0.162 mm wide microstrip trace.

The figure below shows the location of the measurement reference plane.

Measurement reference plane  
for the APM6 connector side

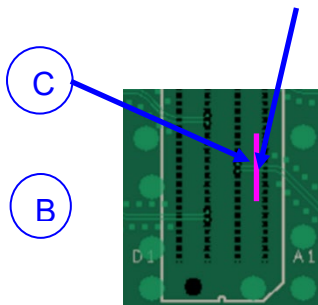

Measurement reference plane  
for the APF6 connector side

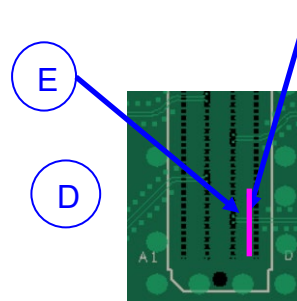

Figure 14

**Series:** APM6/APF6

**Description:** 0.635 mm pitch AcceleRate® HP High-Performance Array, 5 mm Stack Height, Differential RF Analog Application

## Appendix C – Test and Measurement Setup

For frequency domain measurements, the test instrument is the Keysight N5225B PNA-L network analyzer. Frequency domain data are obtained directly from the instrument and figures are generated by Keysight ADS. The network analyzer is configured as follows:

Start Frequency – 10 MHz

Stop Frequency – 40 GHz

Number of points – 4000

IFBW – 1 KHz

### N5225B Measurement Setup

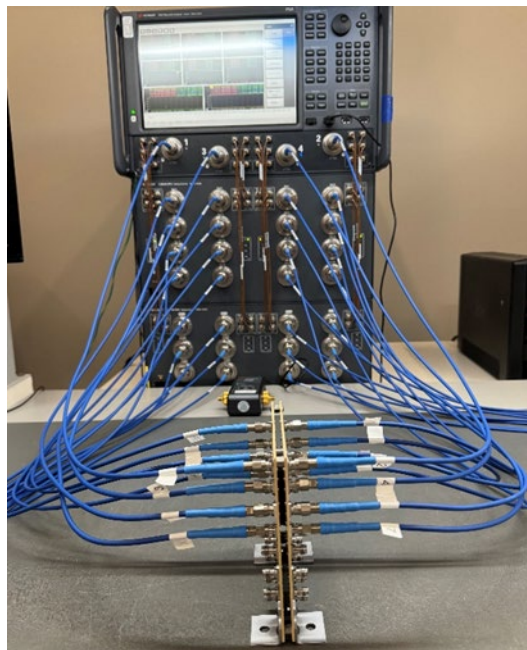

Figure 15

### Test Instruments

<u>QTY</u>	<u>Description</u>
1	Keysight N5225B PNA Network Analyzer (10 MHz to 50 GHz)
1	Keysight N4694-60003 Ecal (10 MHz to 50 GHz)

### Test Cables & Adapters

<u>QTY</u>	<u>Description</u>
16	1m Junkosha 2.4mm male to female cables

**Series:** APM6/APF6

**Description:** 0.635 mm pitch AcceleRate® HP High-Performance Array, 5 mm Stack Height, Differential RF Analog Application

## **Appendix D - Frequency and Time Domain Measurements**

### **Frequency (S-Parameter) Domain Procedures**

The quality of any data taken with a network analyzer is directly related to the quality of the calibration standards and the use of proper test procedures. For this reason, extreme care is taken in the design of the thru-calibration standards, the SI test boards, and the selection of the PCB vendor.

A coaxial SOLT calibration is performed using N4694-60003 Ecal module. Then DUT measurements are performed under SOLT calibration. The measurements include the effect of test fixture. The measurements of the 2X THRU line standards are required to remove the test fixture effect.

## **Appendix E – Glossary of Terms**

ADS – Advanced Design Systems

FD – Frequency domain

FEXT – Far-End Crosstalk

GSG – Ground–Signal–Ground; geometric configuration

GSSG - Ground–Signal–Signal–Ground; geometric configuration

NEXT – Near-End Crosstalk

PCB – Printed Circuit Board

PS FEXT – Power Sum Far- End Crosstalk

PS NEXT - Power Sum Near- End Crosstalk

SE – Single-Ended

SI – Signal Integrity

SOLT – acronym used to define Short, Open, Load & Thru Calibration Standards

TD – Time Domain

TDA – Time Domain Analysis

TDR – Time Domain Reflectometry

TDT – Time Domain Transmission

VSWR – Voltage Standing Wave Ratio

Z – Impedance (expressed in ohms)