

MARCH 24, 2008

TEST REPORT #207864

SEM/TEM SERIES CONNECTOR TESTING

PART NUMBER

SEM-125-02-03.0-H-D-WT

TEM-125-02-03.0-H-D-WT

SAMTEC, INC.



APPROVED BY: DOMINIC ARPINO
PROGRAM MANAGER
CONTECH RESEARCH, INC.

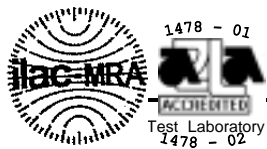

REVISION HISTORY

DATE	REV. NO.	DESCRIPTION	ENG.
3/24/2008	1.0	Initial Issue	DA

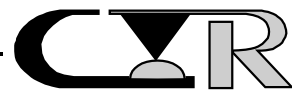
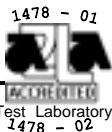

CERTIFICATION

This is to certify that the SEM/TEM connector series evaluation described herein was designed and executed by personnel of Contech Research, Inc. It was performed with the concurrence of Samtec, Inc. of New Albany, IN who was the test sponsor.

All equipment and measuring instruments used during testing were calibrated and traceable to NIST according to ISO 10012-1, ANSI/NCSL Z540-1 and MIL-STD-45662 as applicable.

All data, raw and summarized, analysis and conclusions presented herein are the property of the test sponsor. No copy of this report, except in full, shall be forwarded to any agency, customer, etc., without the written approval of the test sponsor and Contech Research.



DOMINIC ARPINO
PROGRAM MANAGER
CONTECH RESEARCH, INC.

DA:cf

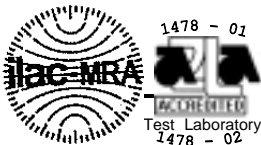

SCOPE

To perform qualification testing on the SEM/TEM series connector as manufactured and submitted by the test sponsor Samtec, Inc.

APPLICABLE DOCUMENTS

1. Unless otherwise specified, the following documents of issue in effect at the time of testing performed form a part of this report to the extent as specified herein. The requirements of sub-tier specifications and/or standards apply only when specifically referenced in this report.
2. Samtec Specifications: TC073-1549
3. Standards: EIA Publication 364

TEST SAMPLES AND PREPARATION

1. The following test samples were submitted by the test sponsor, Samtec, Inc., for the evaluation to be performed by Contech Research, Inc.

<u>Description</u>	<u>Part Number</u>
a) Receptacle Connector	SEM-125-02-03.0-H-D-WT
b) Plug Connector	TEM-125-02-03.0-H-D-WT

2. Test samples were supplied assembled and terminated to test boards by the test sponsor. Specific test boards were designed for the following tests:
 - IR/DWV
 - LLCR
 - Nanosecond Event Detection
3. The test samples for vibration and shock were prepared by terminating all positions in series for monitoring contact events during vibration and/or shock.
4. Unless otherwise specified in the test procedures used, no further preparation was used.

TEST SELECTION

1. See Test Plan Flow Diagram, Figure #1, for test sequences used.

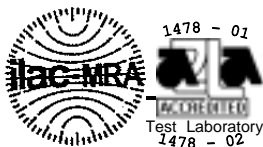

TEST SELECTION -continued

2. Test set ups and/or procedures which are standard or common are not detailed or documented herein provided they are certified as being performed in accordance with the applicable (industry or military) test methods, standards and/or drawings as specified in the detail specification.

SAMPLE CODING

1. All samples were coded. Mated test samples remained with each other throughout the test group/sequences for which they were designated. Coding was performed in a manner which remained legible for the test duration.
2. The test samples were coded in the following manner:

Seq A: Group A - A-A-1, A-A-2
Group B1 - A-B1-1, A-B1-2
Group B2 - A-B2-1, A-B2-2
Group B3 - A-B3-1, A-B3-2

Seq B: Group A1 - B-A-1, B-A-2, B-A-3, B-A-4, B-A-5, B-A-6,
B-A-7, B-A-8

Seq C: Group A - C-A-1, C-A-2, C-A-3, C-A-4, C-A-5, C-A-6,
C-A-7, C-A-8

Seq D: Group A - D-A-1, D-A-2, D-A-3

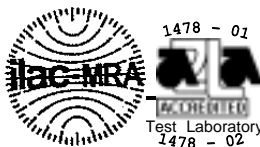
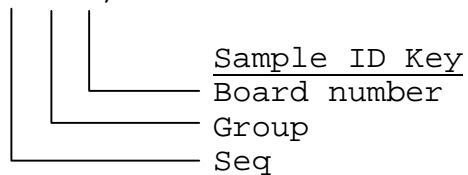
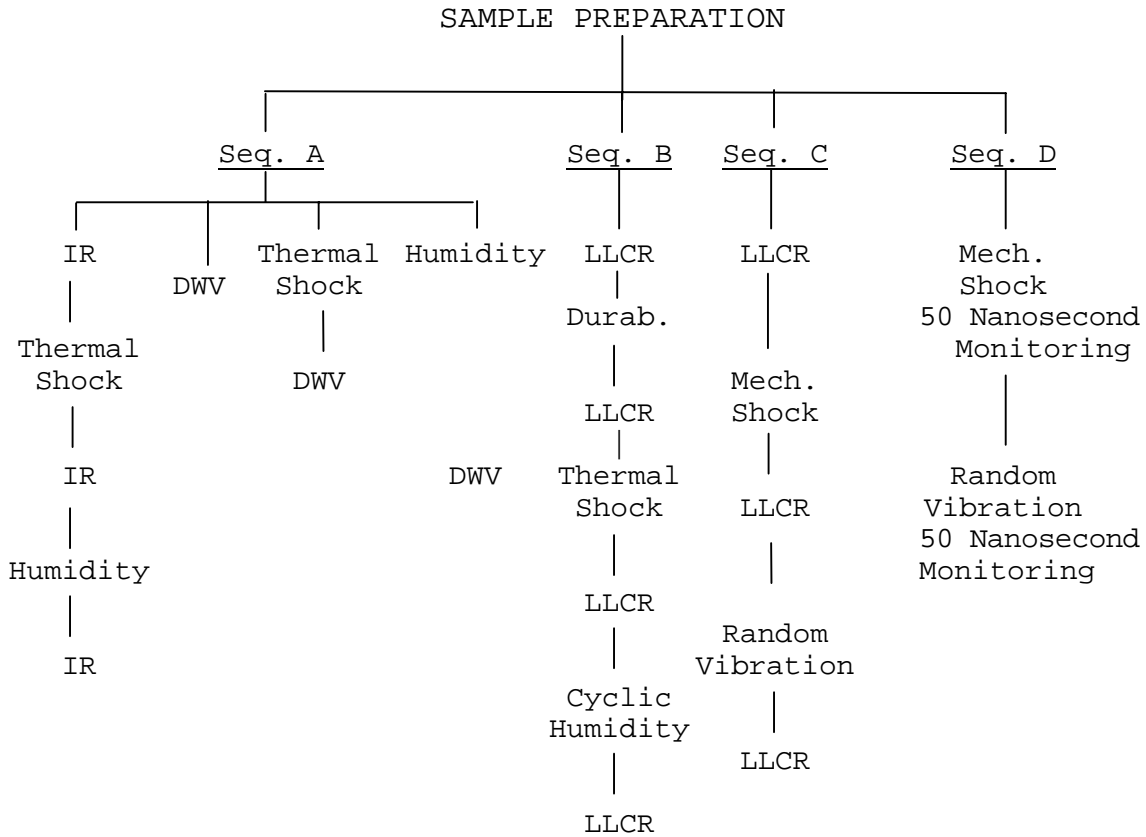

FIGURE #1

TEST PLAN FLOW DIAGRAM



Group B1 Group B2 Group B3 Group A Group A Group A Group A

IR : Insulation Resistance
 DWV : Dielectric Withstanding Voltage
 LLCR : Low Level Circuit Resistance

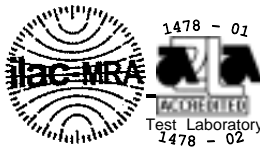

DATA SUMMARY

<u>TEST</u>	<u>REQUIREMENT</u>	<u>RESULTS</u>
<u>SEQUENCE A</u>		
<u>GROUP A</u>		
Insulation Resistance	1000 Megohms Min.	>50,000 Megohms
Thermal Shock	No Damage	Passed
Insulation Resistance	1000 Megohms Min.	>50,000 Megohms
Humidity	No Damage	Passed
Insulation Resistance	1000 Megohms Min.	>50,000 Megohms
<u>GROUP B1</u>		
DWV	900 VAC	Passed
<u>GROUP B2</u>		
Thermal Shock	No Damage	Passed
DWV	900 VAC	Passed
<u>GROUP B3</u>		
Humidity	No Damage	Passed
DWV	900 VAC	Passed
<u>SEQUENCE B</u>		
LLCR	Record	12.15 mΩ MAX.
Durability	No Damage	Passed
LLCR	+10.0 mΩ Max.Chg.	+3.4 mΩ MAX.CHG.
Thermal Shock	No Damage	Passed
LLCR	+10.0 mΩ Max.Chg.	+1.8 mΩ MAX.CHG.
Cyclic Humidity	No Damage	Passed
LLCR	+10.0 mΩ Max.Chg.	+0.5 mΩ MAX.CHG.
<u>SEQUENCE C</u>		
<u>GROUP A</u>		
LLCR	Record	11.3 mΩ MAX.
Mechanical Shock	No Damage	Passed
LLCR	+10.0 mΩ Max.Chg.	+1.8 mΩ MAX.CHG.
Random Vibration	No Damage	Passed
LLCR	+10.0 mΩ Max.Chg.	+3.3 mΩ MAX.CHG.

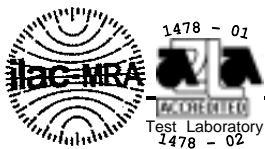

DATA SUMMARY -continued

<u>TEST</u>	<u>REQUIREMENT</u>	<u>RESULTS</u>
<u>SEQUENCE D</u>		
Mechanical Shock	No Damage	Passed
	50 Nanosecond	Passed
Random Vibration	No Damage	Passed
	50 Nanosecond	Passed



EQUIPMENT LIST

ID#	Next Cal	Last Cal	Equipment Name	Manufacturer	Model #	Serial #	Accuracy	Freq. Cal
14	6/26/2008	6/26/2007	Accelerometer	PCB Piezotronics	302A	7040	See Cal Cert	12mon
27			Temp. Humid. Chamber	Blue M Co.	FR-256PC-1	F2-249	See Cal Cert	Ea Test
33			Vib. Power Amp	Ling Dynamics	MPA4	149	N/A	N/A
34			Shock Machine	Avco	SM110-3	1047	See ID# 14 & 117	Ea Test
86			Shaker Table	MB Elect.	C10E	141	N/A	N/A
95	11/8/2008	11/8/2007	AC Hypot	Peschell Instr.	P10*	5570	±3% Full Scale	12mon
192			Vertical Thermal Shock	Cincinnati Sub-Zero	VTS-1-5-3	88-11094	See Cal Cert	Ea Test
207	12/6/2008	12/6/2007	Micro-Ohm Meter	Keithley Co.	580	438208	See Cal Cert	12mon
244	10/5/2008	10/5/2007	Micro-Ohm Meter	Keithley Instr.	580-1	467496	See Cal Cert	12mon
295	10/16/2008	10/16/2007	Micro-Ohm Meter	Keithley Instr.	580	480781	See Cal Cert	12 mon.
321	3/12/2009	3/12/2008	AC-DC Hipot/Megometer	Hipotronics Co.	H300B	DS16-201	See Cal Cert	12 mon.
518			Computer	ARC Elect.	486-40	N/A	N/A	N/A
601			Computer	A.M.I.	P111-450	082714	N/A	N/A
677	10/5/2008	10/5/2007	Microohm Meter	Keithley Co.	580	0685122	See Cal Cert	12 mon
991			Sig Processor interface	Agilent	35651B	n/a	N/A	N/A
1032			Computer	Magitronic	486DX4	100VL	N/A	N/A
1231			Temp-humid-Chamber	Blue M.	FR-381B-MP	FL-520	See Manual	Ea Test
1243			Computer	ARC Co.	P450	BU-001	N/A	N/A
1276			Computer	ARC.Co.	Pent-450	N/A	N/A	N/A
1314	2/7/2009	2/7/2008	Multiplexer card	Keithley Co.	7708	0862544	See CERT	12mon
1315	2/7/2009	2/7/2008	Data Aquisition Multimeter	Keithley Co.	2700	0862680	See CERT	12mon
1361	2/7/2009	2/7/2008	Multiplexer Card	Keithley	7708	1067661	See Cal Cert	12mon
1438			Main Frame	Hewlett Packard	35650	2911A00927	N/A	Ea Test
1439	1/21/2009	1/21/2008	Programable DAC Unit	Hewlett Packard	35656A	3007A00107	See Cal Cert	12 mo
1440	1/21/2009	1/21/2008	8 Chan Input Module	Hewlett Packard	35655A	2911A00337	N/A	12mon
1512			Computer	Comp USA	Pentium 3	N/A	N/A	N/A
1543			Computer	IBM	8183W76	KCTT6T7	N/A	N/A

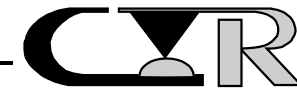

Contech Research

An Independent Test and Research Laboratory

TEST RESULTS

SEQUENCE A

Group A

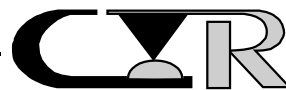
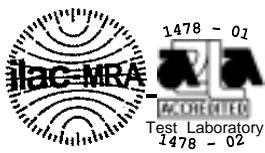

PROJECT NO.: 207864

SPECIFICATION: TC073-1549

PART NO.: SEM-125-02-03.0-H-D-WT PART DESCRIPTION: SEM/TEM
TEM-125-02-03.0-H-D-WT Conn.

SAMPLE SIZE: 2 Samples

TECHNICIAN: BE

START DATE: 2/21/08

COMPLETE DATE: 2/21/08

ROOM AMBIENT: 23°C

RELATIVE HUMIDITY: 21%

EQUIPMENT ID#: 321

INSULATION RESISTANCE (IR)

PURPOSE:

To determine the resistance of insulation materials to leakage of current through or on the surface of these materials when a DC potential is applied.

PROCEDURE:

1. The test was performed in accordance with EIA 364, Test Procedure 21.
2. Test Conditions:
 - a) Between Adjacent Contacts : Yes
 - b) Between Rows : Yes
 - c) Mated Condition : Mated
 - d) Mounting Condition : Mounted
 - e) Electrification Time : 2.0 Minutes
 - f) Test Voltage : 500 VDC
3. The test voltage was applied to designated test points on the board.

REQUIREMENTS:

When the specified test voltage is applied, the insulation resistance shall not be less than 1,000 megohms.

RESULTS:

The insulation resistance exceeded 50,000 megohms.



PROJECT NO.: 207864

SPECIFICATION: TC073-1549

PART NO.: SEM-125-02-03.0-H-D-WT PART DESCRIPTION: SEM/TEM
TEM-125-02-03.0-H-D-WT Conn.

SAMPLE SIZE: 2 Samples

TECHNICIAN: BE

START DATE: 2/22/08

COMPLETE DATE: 2/26/08

ROOM AMBIENT: 22°C

RELATIVE HUMIDITY: 20%

EQUIPMENT ID#: 192, 1314, 1315, 1361

THERMAL SHOCK

PURPOSE:

To determine the resistance of a given electrical connector to exposure at extremes of high and low temperatures and the shock of alternate exposures to these extremes, simulating the worst probable conditions of storage, transportation and application.

PROCEDURE:

1. The test environment was performed in accordance with EIA 364, Test Procedure 32, with the following conditions:
2. Test Conditions:
 - a) Number of Cycles : 100 Cycles
 - b) Hot Extreme : +85 +3°C/-0°C
 - c) Cold Extreme : -55 +0°C/-3°C
 - d) Time at Temperature : 30 Minutes
 - e) Mating Conditions : Mated
 - f) Mounting Conditions : Mounted
 - g) Transfer Time : Instantaneous
3. The total number of cycles was performed continuously.
4. Prior to performing variable measurements, the test samples were allowed to recover to room ambient conditions.
5. All subsequent variable testing was performed in accordance with the procedures previously indicated.

REQUIREMENTS: See Next Page

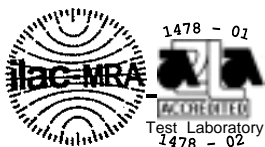

REQUIREMENTS:

1. There shall be no evidence of physical damage or deterioration of the test samples so exposed.
2. The insulation resistance shall exceed 1,000 megohms.

RESULTS:

1. There was no evidence of visual or physical damage to the test samples as tested.
2. The following is a summary of the observed data:

<u>Sample ID#</u>	<u>INSULATION RESISTANCE (Megohms)</u>
A-A-1	>50,000
A-A-2	>50,000

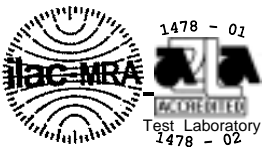

PROJECT NO.: 207864

SPECIFICATION: TC073-1549

PART NO.: SEM-125-02-03.0-H-D-WT PART DESCRIPTION: SEM/TEM
TEM-125-02-03.0-H-D-WT Conn.

SAMPLE SIZE: 2 Samples

TECHNICIAN: BE

START DATE: 2/29/08

COMPLETE DATE: 3/10/08

ROOM AMBIENT: 23°C

RELATIVE HUMIDITY: 18%

EQUIPMENT ID#: 27, 1314, 1315, 1361

HUMIDITY (THERMAL CYCLING)

PURPOSE:

1. The purpose of this test is to permit evaluation of the properties of materials used in connectors as they are influenced or deteriorated by the effects of high humidity and heat conditions. Measurements made under high humidity conditions may reflect the peculiar conditions under which the readings were made, and should be compared only to initial readings when careful analysis indicates that such a comparison is valid and applicable.
2. This test obtains added effectiveness in employment of temperature cycling that provides a breathing action, inducing corrosion processes, and the introduction of moisture into partially sealed test samples. This condition imposes a vapor pressure on the samples which constitutes the major force behind the moisture migration and penetration.

PROCEDURE:

1. The test environment was performed in accordance with EIA 364, Test Procedure 31, Method III (omit Step 7a, 7b) with the following conditions:
2. Test Conditions:
 - a) Relative Humidity : 90% to 95%
 - b) Temperature Conditions : 25°C to 65°C
 - c) Cold Cycle : No
 - d) Polarizing Voltage : No
 - e) Mating Conditions : Mated
 - f) Mounting Conditions : Mounted
 - g) Duration : 240 hours



PROCEDURE: -continued

3. All subsequent variable testing was performed in accordance with the procedures previously indicated.
4. Prior to performing variable measurements, the test samples were allowed to recover to room ambient conditions.

REQUIREMENTS:

1. There shall be no evidence of physical deterioration of the test samples as tested.
2. The final insulation resistance shall not be less than 1,000 megohms.

RESULTS:

1. The test samples as tested showed no evidence of physical deterioration.
3. The following is a summary of the observed data:

<u>Sample ID#</u>	<u>INSULATION RESISTANCE</u> <u>(Megohms)</u>
A-A-1	>50,000
A-A-2	>50,000

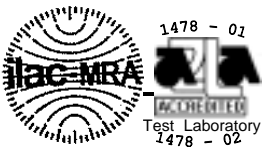

TEST RESULTS

SEQUENCE A

Group B1

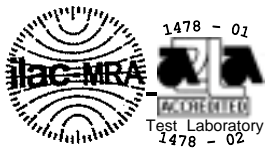

PROJECT NO.: 207864

SPECIFICATION: TC073-1549

PART NO.: SEM-125-02-03.0-H-D-WT PART DESCRIPTION: SEM/TEM
TEM-125-02-03.0-H-D-WT Conn.

SAMPLE SIZE: 2 Samples

TECHNICIAN: BE

START DATE: 3/10/08

COMPLETE DATE: 3/10/08

ROOM AMBIENT: 23°C

RELATIVE HUMIDITY: 21%

EQUIPMENT ID#: 95

DIELECTRIC WITHSTANDING VOLTAGE (SEA LEVEL)

PURPOSE:

To determine if the connectors can operate at its rated voltage and withstand momentary overpotentials due to switching, surges and other similar phenomenon.

PROCEDURE:

1. The test was performed in accordance with EIA 364, Test Procedure 20.
2. Test Conditions:
 - a) Between Adjacent Contacts : Yes
 - b) Between Rows : Yes
 - c) Mated Condition : Mated
 - d) Mounting Condition : Mounted
 - e) Hold Time : 60 Seconds
 - f) Rate of Application : 500 volts/sec.
 - g) Test Voltage : 900 VAC
3. The voltage was applied to specific test points on the board.

REQUIREMENTS:

When the specified test voltage is applied, there shall be no evidence of breakdown, arcing, etc.

RESULTS:

All test samples as tested met the requirements as specified.

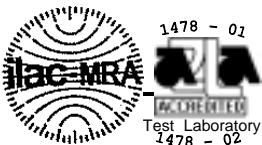

TEST RESULTS

SEQUENCE A

Group B2

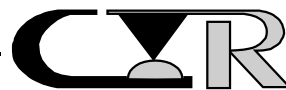
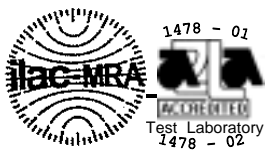

PROJECT NO.: 207864

SPECIFICATION: TC073-1549

PART NO.: SEM-125-02-03.0-H-D-WT PART DESCRIPTION: SEM/TEM
TEM-125-02-03.0-H-D-WT Conn.

SAMPLE SIZE: 2 Samples

TECHNICIAN: BE

START DATE: 2/22/08

COMPLETE DATE: 2/26/08

ROOM AMBIENT: 23°C

RELATIVE HUMIDITY: 50%

EQUIPMENT ID#: 192, 1314, 1315, 1361

THERMAL SHOCK

PURPOSE:

To determine the resistance of a given electrical connector to exposure at extremes of high and low temperatures and the shock of alternate exposures to these extremes, simulating the worst probable conditions of storage, transportation and application.

PROCEDURE:

1. The test environment was performed in accordance with EIA 364, Test Procedure 32, with the following conditions:
2. Test Conditions:
 - a) Number of Cycles : 100 Cycles
 - b) Hot Extreme : +85 +3°C/-0°C
 - c) Cold Extreme : -55 +0°C/-3°C
 - d) Time at Temperature : 30 Minutes
 - e) Mating Conditions : Mated
 - f) Mounting Conditions : Mounted
 - g) Transfer Time : Instantaneous
3. The total number of cycles was performed continuously.
4. All subsequent variable testing was performed in accordance with the procedures as previously indicated.
5. Prior to performing variable measurements, the test samples were allowed to recover to room ambient conditions.

REQUIREMENTS: See Next Page

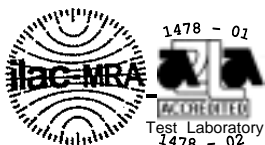

REQUIREMENTS:

1. There shall be no evidence of physical damage to the test samples as tested.
2. When a 900 VAC test voltage is applied, there shall be no evidence of arcing, breakdown, etc.

RESULTS:

1. There was no evidence of physical damage to the test samples as tested.
2. There was no evidence of arcing, breakdown, etc., when a 900 Vac voltage was applied.

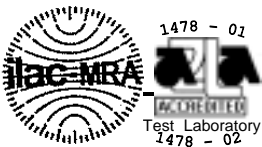

TEST RESULTS

SEQUENCE A

Group B3

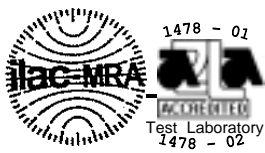

PROJECT NO.: 207864

SPECIFICATION: TC073-1549

PART NO.: SEM-125-02-03.0-H-D-WT PART DESCRIPTION: SEM/TEM
TEM-125-02-03.0-H-D-WT Conn.

SAMPLE SIZE: 2 Samples

TECHNICIAN: BE

START DATE: 2/29/08

COMPLETE DATE: 3/10/08

ROOM AMBIENT: 23°C

RELATIVE HUMIDITY: 18%

EQUIPMENT ID#: 27, 1314, 1315, 1361

HUMIDITY (THERMAL CYCLING)

PURPOSE:

1. The purpose of this test is to permit evaluation of the properties of materials used in connectors as they are influenced or deteriorated by the effects of high humidity and heat conditions. Measurements made under high humidity conditions may reflect the peculiar conditions under which the readings were made, and should be compared only to initial readings when careful analysis indicates that such a comparison is valid and applicable.
2. This test obtains added effectiveness in employment of temperature cycling that provides a breathing action, inducing corrosion processes, and the introduction of moisture into partially sealed test samples. This condition imposes a vapor pressure on the samples which constitutes the major force behind the moisture migration and penetration.

PROCEDURE:

1. The test environment was performed in accordance with EIA 364, Test Procedure 31 Method III (omit Step 7a,7b), with the following conditions:

-continued on next page.



PROCEDURE: -continued

2. Test Conditions:

- a) Relative Humidity : 90% to 95%
- b) Temperature Conditions : 25°C to 65°C
- c) Cold Cycle : No
- d) Polarizing Voltage : No
- e) Mating Conditions : Mated
- f) Mounting Conditions : Mounted
- g) Duration : 240 hours

3. The final dielectric withstanding voltage test was performed in accordance with EIA 364, Test Procedure 20 and the procedures as previously indicated.

4. The voltage was applied to specific test points on the board.

REQUIREMENTS:

- 1. There shall be no evidence of physical deterioration of the test samples as tested.
- 2. There shall be no evidence of arcing or breakdown when a 900 VAC test voltage is applied.

RESULTS:

- 1. The test samples as tested showed no evidence of physical deterioration.
- 2. There was no evidence of breakdown, arcing, etc., when a 900 VAC test voltage was applied.



TEST RESULTS

SEQUENCE B

Group A

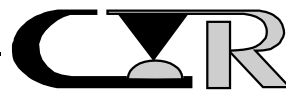
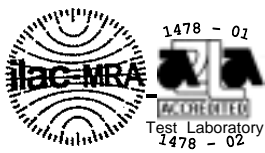

PROJECT NO.: 207864

SPECIFICATION: TC073-1549

PART NO.: SEM-125-02-03.0-H-D-WT PART DESCRIPTION: SEM/TEM
TEM-125-02-03.0-H-D-WT Conn.

SAMPLE SIZE: 8 Samples

TECHNICIAN: BE

START DATE: 2/21/08

COMPLETE DATE: 3/10/08

ROOM AMBIENT: 23°C

RELATIVE HUMIDITY: 21%

EQUIPMENT ID#: 601, 677

LOW LEVEL CIRCUIT RESISTANCE (LLCR)

PURPOSE:

1. To evaluate contact resistance characteristics of the contact systems under conditions where applied voltages and currents do not alter the physical contact interface and will detect oxides and films which degrade electrical stability. It is also sensitive to and may detect the presence of fretting corrosion induced by mechanical or thermal environments as well as any significant loss of contact pressure.
2. This attribute was monitored after each preconditioning and/or test exposure in order to determine said stability of the contact systems as they progress through the applicable test sequences.
3. The electrical stability of the system is determined by comparing the initial resistance value to that observed after a given test exposure. The difference is the change in resistance occurring whose magnitude establishes the stability of the interface being evaluated.

PROCEDURE:

1. The test was performed in accordance with EIA 364, Test Procedure 23, with the following conditions:

-continued on next page.

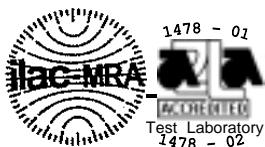

PROCEDURE: -continued

2. Test Conditions:

- a) Test Current : 10 milliamps
- b) Open Circuit Voltage : 20 millivolts

REQUIREMENTS:

Low level circuit resistance shall be measured and recorded.

RESULTS:

1. The following is a summary of the data observed:

LOW LEVEL CIRCUIT RESISTANCE
(Milliohms)

<u>Sample ID#</u>	<u>Avg.</u>	<u>Max.</u>	<u>Min.</u>
B-A-1	9.3	10.6	8.7
B-A-2	9.8	11.0	9.3
B-A-3	10.1	12.1	9.3
B-A-4	9.4	10.4	8.8
B-A-5	9.3	10.3	8.7
B-A-6	9.4	11.8	8.5
B-A-7	9.4	9.9	8.7
B-A-8	9.4	10.7	8.7

2. See data files 20786401 through 20786408 for individual data points.



PROJECT NO.: 207864

SPECIFICATION: TC073-1549

PART NO.: SEM-125-02-03.0-H-D-WT PART DESCRIPTION: SEM/TEM
TEM-125-02-03.0-H-D-WT Conn.

SAMPLE SIZE: 8 Samples

TECHNICIAN: BE

START DATE: 11/21/07

COMPLETE DATE: 11/21/07

ROOM AMBIENT: 24°C

RELATIVE HUMIDITY: 30%

EQUIPMENT ID#: 244, 1032

DURABILITY

PURPOSE:

1. This is a conditioning sequence which is used to induce the type of wear on the contacting surfaces which may occur under normal service conditions. The connectors are mated and unmated a predetermined number of cycles. Upon completion, the units being evaluated are exposed to the environments as specified to assess any impact on electrical stability resulting from wear or other wear dependent phenomenon.
2. This type of conditioning sequence is also used to mechanically stress the connector system as would normally occur in actual service. This sequence in conjunction with other tests is used to determine if a significant loss of contact pressure occurs from said stresses which in turn, may result in an unstable electrical condition to exist.

PROCEDURE:

1. The test was performed in accordance with EIA 364, Test Procedure 09.
2. Test Conditions:
 - a) No. of Cycles : 100
 - b) Rate : 500 cycles per hour
3. The test samples were cycled manually using a fixture and an XY table for alignment.

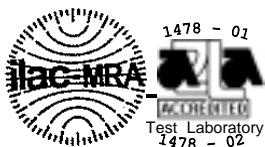

PROCEDURE: -continued

4. Care was taken to prevent the mating faces of the test samples from contacting each other.
5. All subsequent variable testing was performed in accordance with the procedures previously indicated.

REQUIREMENTS:

1. There shall be no evidence of physical damage to the test samples so tested.
2. The change in low level circuit resistance shall not exceed +10.0 milliohms.

RESULTS:

1. There was no evidence of physical damage to the test samples as tested.
2. The following is a summary of the data observed:

CHANGE IN
LOW LEVEL CIRCUIT RESISTANCE
(Milliohms)

<u>Sample ID#</u>	<u>Avg. Change</u>	<u>Max. Change</u>
B-A-1	-0.3	+0.5
B-A-2	+0.1	+1.1
B-A-3	-0.2	+1.0
B-A-4	+0.1	+1.8
B-A-5	+0.2	+3.4
B-A-6	+0.0	+1.3
B-A-7	+0.3	+1.1
B-A-8	-0.3	+0.6

3. See data files 20786401 through 2078608 for individual data points.

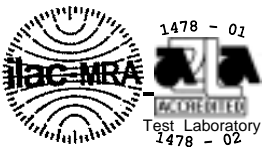

PROJECT NO.: 207864

SPECIFICATION: TC073-1549

PART NO.: SEM-125-02-03.0-H-D-WT PART DESCRIPTION: SEM/TEM
TEM-125-02-03.0-H-D-WT Conn.

SAMPLE SIZE: 8 Samples

TECHNICIAN: SR/JG/GL

START DATE: 11/21/07

COMPLETE DATE: 11/26/07

ROOM AMBIENT: 24°C

RELATIVE HUMIDITY: 30%

EQUIPMENT ID#: 192, 207, 244, 295, 518, 1032, 1276, 1314,
1315, 1361, 1512

THERMAL SHOCK

PURPOSE:

To determine the resistance of a given electrical connector to exposure at extremes of high and low temperatures and the shock of alternate exposures to these extremes, simulating the worst probable conditions of storage, transportation and application.

PROCEDURE:

1. The test environment was performed in accordance with EIA 364, Test Procedure 32, with the following conditions:
2. Test Conditions:
 - a) Number of Cycles : 100 Cycles
 - b) Hot Extreme : +85°C +3°C/-0°C
 - c) Cold Extreme : -55°C +0°C/-3°C
 - d) Time at Temperature : 30 Minutes
 - e) Mating Conditions : Mated
 - f) Mounting Conditions : Mounted
 - g) Transfer Time : Instantaneous
3. The total number of cycles were performed continuously.
4. All subsequent variable testing was performed in accordance with the procedures as previously indicated.
5. Prior to performing variable measurements, the test samples were allowed to recover to room ambient conditions.

REQUIREMENTS: See Next Page

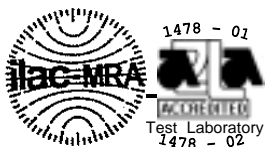

REQUIREMENTS:

1. There shall be no evidence of physical damage to the test samples as tested.
2. The change in low level circuit resistance shall not exceed +10.0 milliohms.

RESULTS:

1. There was no evidence of physical damage to the test samples as tested.
4. The following is a summary of the data observed:

CHANGE IN
LOW LEVEL CIRCUIT RESISTANCE
(Milliohms)

<u>Sample ID#</u>	<u>Avg. Change</u>	<u>Max. Change</u>
B-A-1	-0.5	+1.3
B-A-2	+0.3	+1.8
B-A-3	-1.0	+0.1
B-A-4	-0.7	+1.0
B-A-5	-0.3	+1.2
B-A-6	-0.4	+0.1
B-A-7	-0.5	+0.3
B-A-8	-0.9	+0.1

3. See data files 20786401 through 20786408 for individual data points.

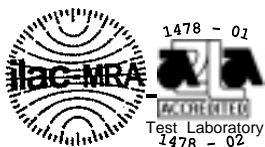

PROJECT NO.: 207864

SPECIFICATION: TC073-1549

PART NO.: SEM-125-02-03.0-H-D-WT PART DESCRIPTION: SEM/TEM
TEM-125-02-03.0-H-D-WT Conn.

SAMPLE SIZE: 8 Samples

TECHNICIAN: BE

START DATE: 11/24/07

COMPLETE DATE: 12/4/07

ROOM AMBIENT: 22°C

RELATIVE HUMIDITY: 21%

EQUIPMENT ID#: 244, 518, 1032, 1231, 1314, 1315, 1361

HUMIDITY (THERMAL CYCLING)

PURPOSE:

To evaluate the impact on electrical stability of the contact system when exposed to any environment which may generate thermal/moisture type failure mechanisms such as:

- a) Fretting corrosion due to wear resulting from micromotion, induced by thermal cycling. Humidity accelerates the oxidation process.
- b) Oxidation of wear debris or from particulates from the surrounding atmosphere which may have become entrapped between the contacting surfaces.
- c) Failure mechanisms resulting from a wet oxidation process.

PROCEDURE:

1. The test environment was performed in accordance with EIA 364, Test Procedure 31, with the following conditions:
2. Test Conditions:
 - a) Preconditioning (24 hours) : 50°C ± 5°C
 - b) Relative Humidity : 90% to 95%
 - c) Temperature Conditions : 25°C to 65°C
 - d) Cold Cycle : No
 - e) Polarizing Voltage : No
 - f) Mating Conditions : Mated
 - g) Mounting Conditions : Mounted
 - h) Duration : 240 hours



PROCEDURE: -continued

3. Prior to performing variable measurements, the test samples were allowed to recover to room ambient conditions.
4. All subsequent variable testing was performed in accordance with the procedures previously indicated.

REQUIREMENTS:

1. There shall be no evidence of physical deterioration of the test samples as tested.
2. The change in low level circuit resistance shall not exceed +10.0 milliohms.

RESULTS:

1. The test samples as tested showed no evidence of physical deterioration.
2. The following is a summary of the data observed:

CHANGE IN
LOW LEVEL CIRCUIT RESISTANCE
(Milliohms)

<u>Sample ID#</u>	<u>Avg. Change</u>	<u>Max. Change</u>
B-A-1	-0.8	+0.5
B-A-2	-0.7	-0.3
B-A-3	-1.5	-0.4
B-A-4	-0.7	+0.1
B-A-5	-0.7	+0.4
B-A-6	-0.7	+0.4
B-A-7	-0.7	+0.1
B-A-8	-0.6	+0.2

3. See data files 20786401 through 20786408 for individual data points.

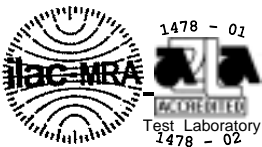

LLCR DATA FILES

DATA FILE NUMBERS

20786401

20786402

20786403

20786404

20786405

20786406

20786407

20786408

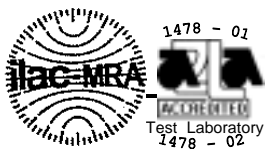

Low Level Contact Resistance					
Project:	207864				Spec: EIA 364, TP 23
Customer:	Samtec				Subgroup: Seq b
Product:	Series SEM/TEM connector			File #:	20786401
Description:	B-A-1				
Open circuit voltage:	20mv			Current:	10ma
Delta values					
units: milliohms					
Temp °C	23	22	22	23	
R.H. %	21	20	23	21	
Date:	21Feb08	22Feb08	27Feb08	10Mar08	
Pos. ID	Initial	Durability	T-Shock	Humidity	
		100X			
1	9.0	-0.3	-0.5	-0.7	
2	9.0	-0.6	-0.5	-0.8	
3	9.3	-0.8	-0.8	-1.0	
4	9.2	-0.2	-0.5	-0.6	
5	9.4	-0.6	-0.7	-0.8	
6	9.3	-0.4	-0.5	-0.6	
7	8.9	-0.1	1.3	0.5	
8	9.3	-0.7	-0.5	-0.9	
9	9.6	-0.1	-0.8	-1.3	
10	9.5	-0.3	-1.0	-1.1	
11	9.4	-0.5	-0.8	-1.0	
12	9.3	-0.5	-0.9	-1.0	
13	9.4	0.0	-0.4	-0.8	
14	10.6	-0.6	-1.5	-1.7	
15	9.1	0.5	-0.6	-0.7	
16	9.3	-0.2	-0.5	-0.8	
17	9.1	-0.3	-0.5	-0.8	
18	9.2	0.3	-0.3	-0.8	
19	8.7	0.2	0.1	-0.4	
20	9.0	-0.2	-0.5	-0.6	
21	9.1	-0.1	-0.3	-0.4	
22	9.4	-0.3	-0.7	-0.8	
23	9.2	-0.5	-0.7	-0.8	
24	9.2	-0.2	-0.5	-0.8	
25	9.2	-0.6	-0.7	-0.8	
MAX	10.6	0.5	1.3	0.5	
MIN	8.7	-0.8	-1.5	-1.7	
AVG	9.3	-0.3	-0.5	-0.8	
STD	0.3	0.3	0.5	0.4	
Open	0	0	0	0	
Tech	BE	BE	BE	BE	
Equip ID	601	601	601	601	
	677	677	677	677	

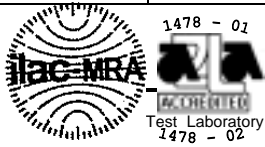

Low Level Contact Resistance					
Project:	207864				Spec: EIA 364, TP 23
Customer:	Samtec				Subgroup: Seq b
Product:	Series SEM/TEM connector			File #:	20786402
Description:	B-A-2				
Open circuit voltage:	20mv			Current:	10ma
Delta values					
units: milliohms					
Temp °C	23	22	22	23	
R.H. %	21	20	23	21	
Date:	21Feb08	22Feb08	27Feb08	10Mar08	
Pos. ID	Initial	Durability	T-Shock	Humidity	
		100X			
1	9.5	-0.4	-0.4	-0.8	
2	9.3	0.3	0.2	-0.3	
3	9.4	-0.2	0.2	-0.3	
4	9.8	-0.2	0.4	-0.8	
5	9.8	0.6	0.5	-0.6	
6	10.1	0.2	0.3	-0.9	
7	9.4	0.7	1.1	-0.4	
8	9.6	0.7	0.7	-0.5	
9	9.6	0.3	0.9	-0.9	
10	10.3	-0.7	-0.4	-1.3	
11	11.0	-0.9	-0.7	-2.2	
12	9.7	0.6	0.8	-0.7	
13	10.7	0.4	1.8	-1.5	
14	10.3	-0.4	-0.3	-1.0	
15	9.9	0.3	1.0	-0.8	
16	9.6	-0.3	0.0	-0.6	
17	9.5	0.4	0.6	-0.3	
18	9.4	0.3	0.2	-0.5	
19	9.5	0.1	-0.2	-0.8	
20	9.7	1.1	0.7	-0.4	
21	9.5	-0.1	0.3	-0.5	
22	9.7	0.5	0.1	-0.6	
23	9.5	0.0	0.4	-0.6	
24	9.6	-0.1	0.1	-0.7	
25	9.4	0.3	0.3	-0.7	
MAX	11.0	1.1	1.8	-0.3	
MIN	9.3	-0.9	-0.7	-2.2	
AVG	9.8	0.1	0.3	-0.7	
STD	0.4	0.5	0.5	0.4	
Open	0	0	0	0	
Tech	BE	BE	BE	BE	
Equip ID	601	601	601	601	
	677	677	677	677	

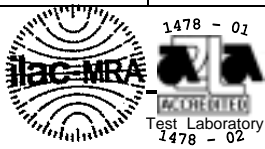

Low Level Contact Resistance				
Project:	207864			Spec: EIA 364, T P 23
Customer:	Samtec			Subgroup: Seq b
Product:	Series SEM/TEM connector			File #: 20786403
Description:	B-A-3			
Open circuit voltage:	20mv			Current: 10ma
		Delta values		
		units: milliohms		
Temp °C	22	22	22	23
R.H. %	20	20	23	21
Date:	22Feb08	22Feb08	27Feb08	10Mar08
Pos. ID	Initial	Durability	T-Shock	Humidity
		100X		
1	9.3	-0.3	-1.1	-1.2
2	9.7	0.3	-1.1	-1.1
3	9.7	-0.4	-1.2	-1.4
4	9.7	-0.1	-1.1	-1.3
5	10.3	-1.0	-1.6	-1.5
6	9.5	0.0	-1.0	-0.9
7	10.1	-0.3	-1.2	-1.7
8	9.9	-1.0	-1.1	-1.4
9	9.9	-0.3	-1.3	-1.6
10	9.9	-0.7	-1.8	-1.7
11	10.0	-0.4	-1.8	-1.8
12	9.7	-0.8	-1.6	-1.5
13	9.9	-0.5	-1.6	-1.6
14	10.1	0.9	-0.8	-1.3
15	10.5	0.1	-1.2	-1.8
16	10.0	1.0	-1.1	-1.6
17	10.0	0.3	-0.7	-1.2
18	10.3	-0.7	-1.2	-1.4
19	9.5	0.0	0.0	-0.4
20	10.8	-1.4	-0.9	-1.7
21	10.0	0.1	-0.8	-1.2
22	12.1	-1.0	-1.9	-2.9
23	11.0	0.4	0.0	-1.8
24	10.1	0.6	0.1	-1.3
25	10.3	-1.0	-0.4	-1.2
MAX	12.1	1.0	0.1	-0.4
MIN	9.3	-1.4	-1.9	-2.9
AVG	10.1	-0.2	-1.0	-1.5
STD	0.6	0.6	0.5	0.4
Open	0	0	0	0
Tech	BE	BE	BE	BE
Equip ID	601	601	601	601
	677	677	677	677

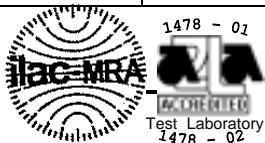

Low Level Contact Resistance				
Project:	207864			Spec: EIA 364, TP 23
Customer:	Samtec			Subgroup: Seq b
Product:	Series SEM/TEM connector			File #: 20786404
Description:	B-A-4			
Open circuit voltage:	20mv			Current: 10ma
		Delta values		
		units: milliohms		
Temp °C	23	22	22	23
R.H. %	21	20	23	21
Date:	21Feb08	22Feb08	27Feb08	10Mar08
Pos. ID	Initial	Durability	T-Shock	Humidity
		100X		
1	8.8	0.3	-0.4	-0.5
2	9.2	0.3	-0.7	-0.6
3	9.1	-0.2	-0.7	-0.5
4	9.3	0.0	-0.6	-0.6
5	9.8	0.0	-1.0	-1.0
6	9.4	1.0	-0.5	-0.3
7	9.1	0.7	-0.5	-0.6
8	9.3	0.7	-0.6	-0.6
9	9.4	-0.6	-1.0	-1.0
10	9.3	0.5	-0.7	-0.7
11	9.8	-0.2	-1.3	-1.2
12	10.4	-1.3	-1.9	-1.6
13	9.7	-0.1	-1.0	-1.1
14	9.9	-0.8	-1.2	-1.0
15	9.8	0.0	-0.9	-1.1
16	9.5	0.0	-0.8	-0.9
17	9.1	1.8	0.1	0.0
18	9.0	0.7	-0.3	-0.4
19	9.0	0.4	-0.3	-0.5
20	9.4	-0.2	-0.8	-0.7
21	9.2	-0.4	-0.7	-0.4
22	9.5	-0.1	-0.6	-0.8
23	9.8	0.3	-0.8	-1.0
24	9.1	-0.1	-0.4	-0.7
25	9.2	0.0	-0.3	0.1
MAX	10.4	1.8	0.1	0.1
MIN	8.8	-1.3	-1.9	-1.6
AVG	9.4	0.1	-0.7	-0.7
STD	0.4	0.6	0.4	0.4
Open	0	0	0	0
Tech	BE	BE	BE	BE
Equip ID	601	601	601	601
	677	677	677	677

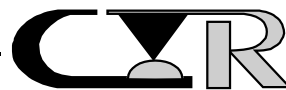
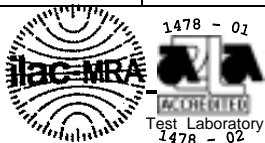

Low Level Contact Resistance				
Project:	207864			Spec: EIA 364, TP 23
Customer:	Samtec			Subgroup: Seq b
Product:	Series SEM/TEM connector			File #: 20786405
Description:	B-A-5			
Open circuit voltage:	20mv			Current: 10ma
		Delta values		
		units: milliohms		
Temp °C	23	22	22	23
R.H. %	21	20	23	21
Date:	21Feb08	22Feb08	27Feb08	10Mar08
Pos. ID	Initial	Durability	T-Shock	Humidity
		100X		
1	9.3	-0.2	-0.5	-1.0
2	8.9	0.3	0.8	0.1
3	9.5	-0.5	-0.6	-0.7
4	9.5	-0.4	-0.6	-0.8
5	9.3	-0.7	-0.9	-0.9
6	9.4	-0.5	-0.8	-0.9
7	8.7	0.3	0.1	-0.2
8	9.3	1.8	0.1	-0.7
9	9.4	1.8	0.2	-0.7
10	9.5	0.4	-0.4	-0.9
11	8.7	3.4	0.6	0.1
12	8.8	0.7	1.2	0.4
13	9.4	0.6	-0.1	-0.5
14	10.3	-0.5	-1.6	-1.8
15	9.3	-0.2	-0.6	-0.8
16	8.8	-0.3	-0.1	-0.4
17	9.3	0.0	-0.3	-0.3
18	9.0	1.2	0.6	-0.3
19	8.8	-0.1	-0.3	-0.2
20	9.9	-0.6	-1.1	-1.1
21	10.0	0.2	-0.4	-0.8
22	9.7	-0.7	-0.9	-1.1
23	9.6	-0.5	-0.7	-1.0
24	9.6	-0.5	-0.8	-1.1
25	9.2	0.0	-0.4	-0.9
MAX	10.3	3.4	1.2	0.4
MIN	8.7	-0.7	-1.6	-1.8
AVG	9.3	0.2	-0.3	-0.7
STD	0.4	1.0	0.6	0.5
Open	0	0	0	0
Tech	BE	BE	BE	BE
Equip ID	601	601	601	601
	677	677	677	677

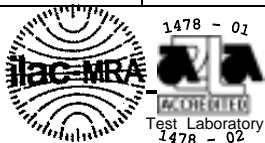

Low Level Contact Resistance				
Project:	207864			Spec: EIA 364, TP 23
Customer:	Samtec			Subgroup: Seq b
Product:	Series SEM/TEM connector			File #: 20786406
Description:	B-A-6			
Open circuit voltage:	20mv			Current: 10ma
		Delta values		
		units: milliohms		
Temp °C	23	22	22	23
R.H. %	21	20	23	21
Date:	21Feb08	22Feb08	27Feb08	10Mar08
Pos. ID	Initial	Durability	T-Shock	Humidity
		100X		
1	9.2	0.0	0.0	-0.4
2	9.3	0.0	-0.2	-0.5
3	9.6	-0.5	-0.3	-0.6
4	10.5	-1.1	-1.0	-1.3
5	9.6	0.1	-0.1	-0.6
6	9.6	0.2	-0.1	-0.7
7	9.7	1.3	-0.7	-1.2
8	10.0	-0.5	-1.2	-1.5
9	8.9	1.1	0.1	-0.4
10	9.1	0.4	-0.2	-0.5
11	11.8	-1.8	-2.6	-3.3
12	9.6	0.3	-0.4	-0.9
13	9.5	-0.2	-0.5	-0.7
14	9.5	0.5	-0.1	-0.7
15	9.3	0.1	-0.6	-1.1
16	9.7	-0.1	-0.9	-1.3
17	8.8	0.7	-0.2	-0.4
18	8.7	0.4	-0.1	-0.4
19	8.5	0.3	-0.3	-0.3
20	8.9	0.3	-0.1	-0.1
21	9.3	-0.4	-0.4	-0.6
22	9.5	-0.2	-0.3	-0.8
23	9.3	-0.1	-0.4	-0.3
24	8.9	0.3	-0.2	-0.3
25	8.7	-0.1	0.0	0.4
MAX	11.8	1.3	0.1	0.4
MIN	8.5	-1.8	-2.6	-3.3
AVG	9.4	0.0	-0.4	-0.7
STD	0.7	0.6	0.5	0.7
Open	0	0	0	0
Tech	BE	BE	BE	BE
Equip ID	601	601	601	601
	677	677	677	677

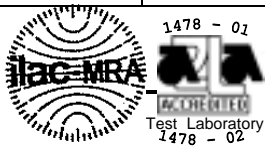

Contech Research

An Independent Test and Research Laboratory

Low Level Contact Resistance				
Project:	207864			Spec: EIA 364, TP 23
Customer:	Samtec			Subgroup: Seq b
Product:	Series SEM/TEM connector			File #: 20786407
Description:	B-A-7			
Open circuit voltage:	20mv			Current: 10ma
Delta values				
units: milliohms				
Temp °C	23	22	22	23
R.H. %	21	20	23	21
Date:	21Feb08	22Feb08	27Feb08	10Mar08
Pos. ID	Initial	Durability	T-Shock	Humidity
		100X		
1	9.1	0.6	-0.7	0.1
2	9.2	0.5	-0.5	-0.4
3	9.2	1.1	-0.6	-0.6
4	9.9	0.3	-1.3	-1.2
5	9.5	0.5	-0.7	-0.6
6	9.6	0.5	-0.8	-0.9
7	8.9	0.8	0.1	-0.2
8	9.5	0.6	-0.6	-0.8
9	9.3	0.1	-0.7	-0.8
10	9.6	0.6	-0.3	-0.6
11	9.9	0.6	-1.0	-1.2
12	9.5	0.2	-0.8	-0.8
13	9.7	0.4	-0.3	-0.6
14	9.8	-0.2	-0.8	-1.1
15	9.8	-0.4	-1.1	-1.3
16	9.7	0.7	-0.6	-0.9
17	9.3	0.9	-0.5	-0.6
18	9.3	0.8	-0.4	-0.7
19	8.9	0.6	0.0	-0.3
20	9.4	-0.5	-0.8	-0.9
21	9.3	-0.2	0.2	-0.5
22	9.6	0.0	0.3	-0.4
23	9.5	-0.2	-0.2	-0.6
24	8.8	0.1	-0.1	-0.4
25	8.7	-0.2	0.0	-0.3
MAX	9.9	1.1	0.3	0.1
MIN	8.7	-0.5	-1.3	-1.3
AVG	9.4	0.3	-0.5	-0.7
STD	0.3	0.4	0.4	0.3
Open	0	0	0	0
Tech	BE	BE	BE	BE
Equip ID	601	601	601	601
	677	677	677	677

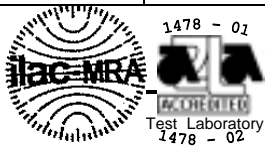

Contech Research

An Independent Test and Research Laboratory

Low Level Contact Resistance					
Project:	207864				Spec: EIA 364, TP 23
Customer:	Samtec				Subgroup: Seq b
Product:	Series SEM/TEM connector			File #:	20786408
Description:	B-A-8				
Open circuit voltage:	20mv			Current:	10ma
Delta values					
units: milliohms					
Temp °C	23	22	22	23	
R.H. %	21	20	23	21	
Date:	21Feb08	22Feb08	27Feb08	10Mar08	
Pos. ID	Initial	Durability	T-Shock	Humidity	
		100X			
1	8.7	0.0	-0.6	-0.2	
2	9.1	-0.4	-1.2	-0.8	
3	8.9	-0.4	-1.1	-0.4	
4	9.4	-0.8	-1.2	-0.7	
5	9.4	-0.9	-1.2	-0.7	
6	9.7	-1.1	-1.5	-0.9	
7	9.4	-0.2	-0.6	-0.5	
8	10.0	-0.2	-1.2	-1.0	
9	9.9	-0.5	-1.3	-0.9	
10	10.0	-0.2	-1.4	-1.2	
11	10.7	-0.7	-2.4	-1.9	
12	10.4	-0.6	-1.8	-1.7	
13	10.4	-1.1	-1.2	-1.5	
14	9.0	0.3	-0.3	0.0	
15	9.3	0.0	-0.6	-0.3	
16	8.9	0.6	-0.3	-0.1	
17	8.7	0.5	-0.2	-0.1	
18	8.7	0.2	-0.3	-0.3	
19	9.0	-0.1	-0.2	-0.5	
20	9.7	-0.8	-1.2	-0.8	
21	9.4	-0.3	-0.9	-0.4	
22	9.3	0.1	-0.3	-0.2	
23	9.2	0.1	0.1	0.2	
24	9.1	-0.1	-0.1	0.0	
25	9.1	-0.1	-0.3	-0.2	
MAX	10.7	0.6	0.1	0.2	
MIN	8.7	-1.1	-2.4	-1.9	
AVG	9.4	-0.3	-0.9	-0.6	
STD	0.5	0.5	0.6	0.5	
Open	0	0	0	0	
Tech	BE	BE	BE	BE	
Equip ID	601	601	601	601	
	677	677	677	677	

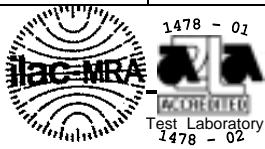

TEST RESULTS

SEQUENCE C

Group A

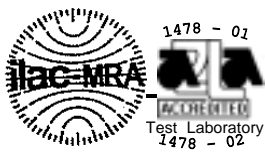

PROJECT NO.: 207864

SPECIFICATION: TC073-1549

PART NO.: SEM-125-02-03.0-H-D-WT PART DESCRIPTION: SEM/TEM
TEM-125-02-03.0-H-D-WT Conn.

SAMPLE SIZE: 8 Samples

TECHNICIAN: BE

START DATE: 2/21/08

COMPLETE DATE: 3/10/08

ROOM AMBIENT: 23°C

RELATIVE HUMIDITY: 21%

EQUIPMENT ID#: 601, 677

LOW LEVEL CIRCUIT RESISTANCE (LLCR)

PURPOSE:

1. To evaluate contact resistance characteristics of the contact systems under conditions where applied voltages and currents do not alter the physical contact interface and will detect oxides and films which degrade electrical stability. It is also sensitive to and may detect the presence of fretting corrosion induced by mechanical or thermal environments as well as any significant loss of contact pressure.
2. This attribute was monitored after each preconditioning and/or test exposure in order to determine said stability of the contact systems as they progress through the applicable test sequences.
3. The electrical stability of the system is determined by comparing the initial resistance value to that observed after a given test exposure. The difference is the change in resistance occurring whose magnitude establishes the stability of the interface being evaluated.

PROCEDURE:

1. The test was performed in accordance with EIA 364, Test Procedure 23, with the following conditions:

-continued on next page.

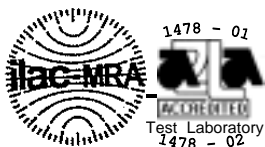

PROCEDURE: -continued

2. Test Conditions:

- a) Test Current : 10 milliamps
- b) Open Circuit Voltage : 20 millivolts

REQUIREMENTS:

Low level circuit resistance shall be measured and recorded.

RESULTS:

1. The following is a summary of the data observed:

LOW LEVEL CIRCUIT RESISTANCE
(Milliohms)

<u>Sample ID#</u>	<u>Avg.</u>	<u>Max.</u>	<u>Min.</u>
C-A-1	9.6	10.3	9.0
C-A-2	9.4	10.2	8.9
C-A-3	9.5	10.1	9.0
C-A-4	9.2	9.7	8.8
C-A-5	10.1	11.3	9.0
C-A-6	10.7	9.3	8.7
C-A-7	9.1	9.9	8.7
C-A-8	9.5	10.1	8.9

2. See data files 20786409 through 20786416 for individual data points.



PROJECT NO.: 207864

SPECIFICATION: TC073-1549

PART NO.: SEM-125-02-03.0-H-D-WT PART DESCRIPTION: SEM/TEM
TEM-125-02-03.0-H-D-WT Conn.

SAMPLE SIZE: 8 Samples

TECHNICIAN: BE

START DATE: 3/5/08

COMPLETE DATE: 3/5/08

ROOM AMBIENT: 23°C

RELATIVE HUMIDITY: 18%

EQUIPMENT ID#: 14, 34, 1543

MECHANICAL SHOCK (SPECIFIED PULSE)

PURPOSE:

To determine the mechanical and electrical integrity of connectors for use with electronic equipment subjected to shocks such as those expected from handling, transportation, etc.

PROCEDURE:

1. The test was performed in accordance with EIA 364, Test Procedure 27.
2. Test Conditions:
 - a) Peak Value : 100 G
 - b) Duration : 6 Milliseconds
 - c) Wave Form : Half-Sine
 - d) Velocity : 11.3 feet per second
 - e) No. of Shocks : 3 Shocks/Direction, 3 Axis (18 Total)
3. Figure #2 illustrates the test sample fixturing utilized during the test.
4. All subsequent variable testing was performed in accordance with the procedures previously indicated.

REQUIREMENTS:

1. There shall be no evidence of physical damage to the test samples as tested.

-continued on next page.

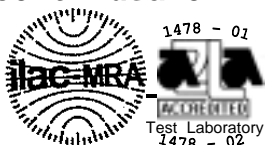

REQUIREMENTS: -continued

2. The change in low level circuit resistance shall not exceed +10.0 milliohms.

RESULTS:

1. There was no evidence of physical damage to the test samples as tested.
2. The following is a summary of the data observed:

CHANGE IN
LOW LEVEL CIRCUIT RESISTANCE
(Milliohms)

<u>Sample ID#</u>	<u>Avg. Change</u>	<u>Max. Change</u>
C-A-1	+0.0	+0.7
C-A-2	+0.4	+1.1
C-A-3	+0.6	+1.8
C-A-4	+0.0	+0.4
C-A-5	-0.2	+0.4
C-A-6	+0.5	+1.4
C-A-7	+0.0	+0.5
C-A-8	-0.2	+0.3

3. See data files 20786409 through 20786416 for individual data points.
4. The Mechanical Shock characteristics are shown in Figures #4 (Calibration Pulse) and #5 (Test Pulse). Each figure displays the shock pulse contained within the upper and lower limits as defined by the appropriate test specification.

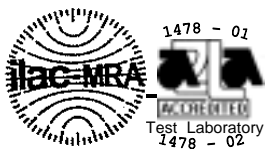

FIGURE #3

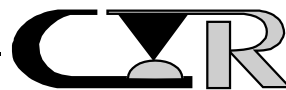
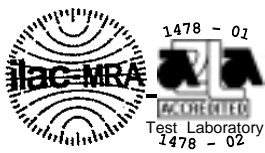
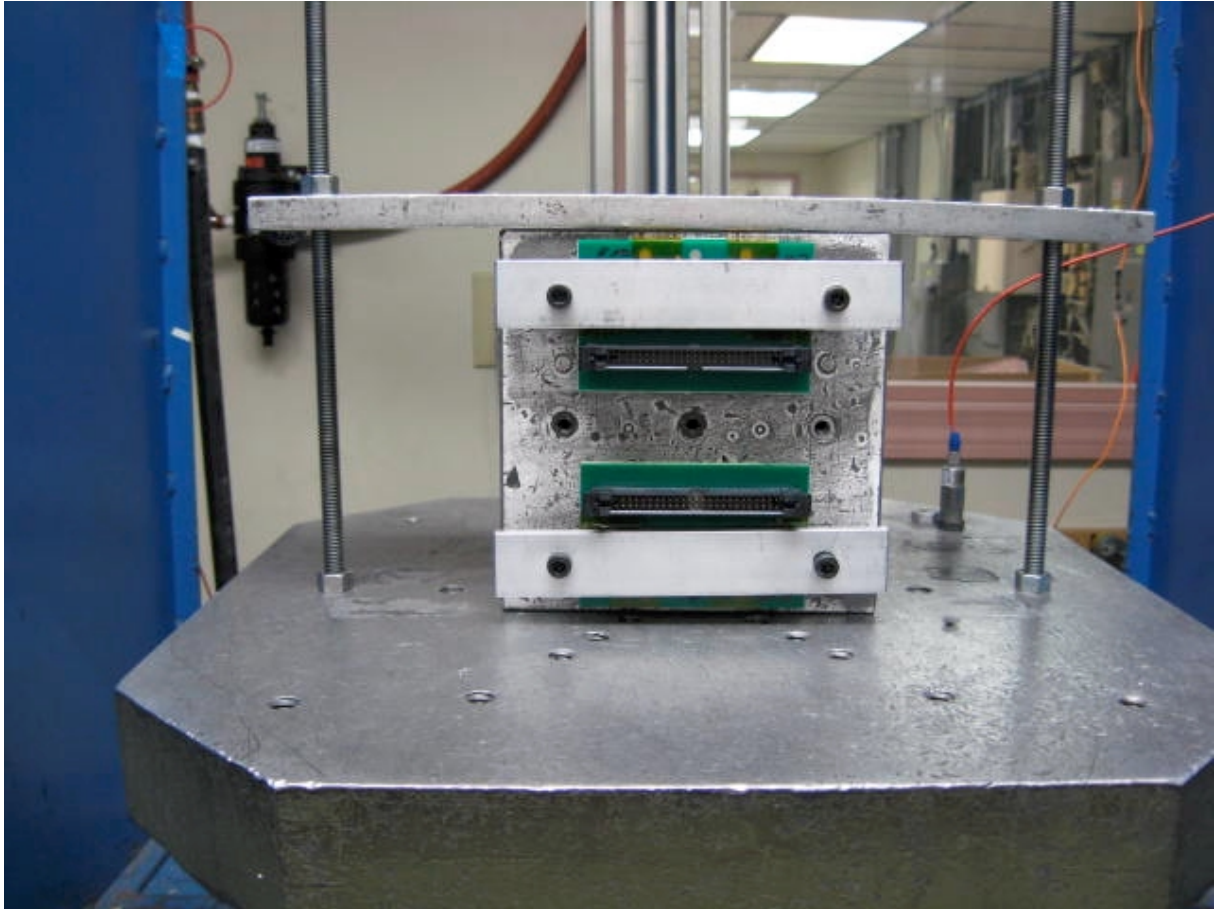

FIGURE #4

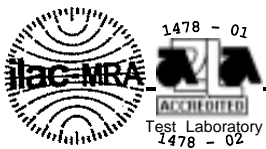
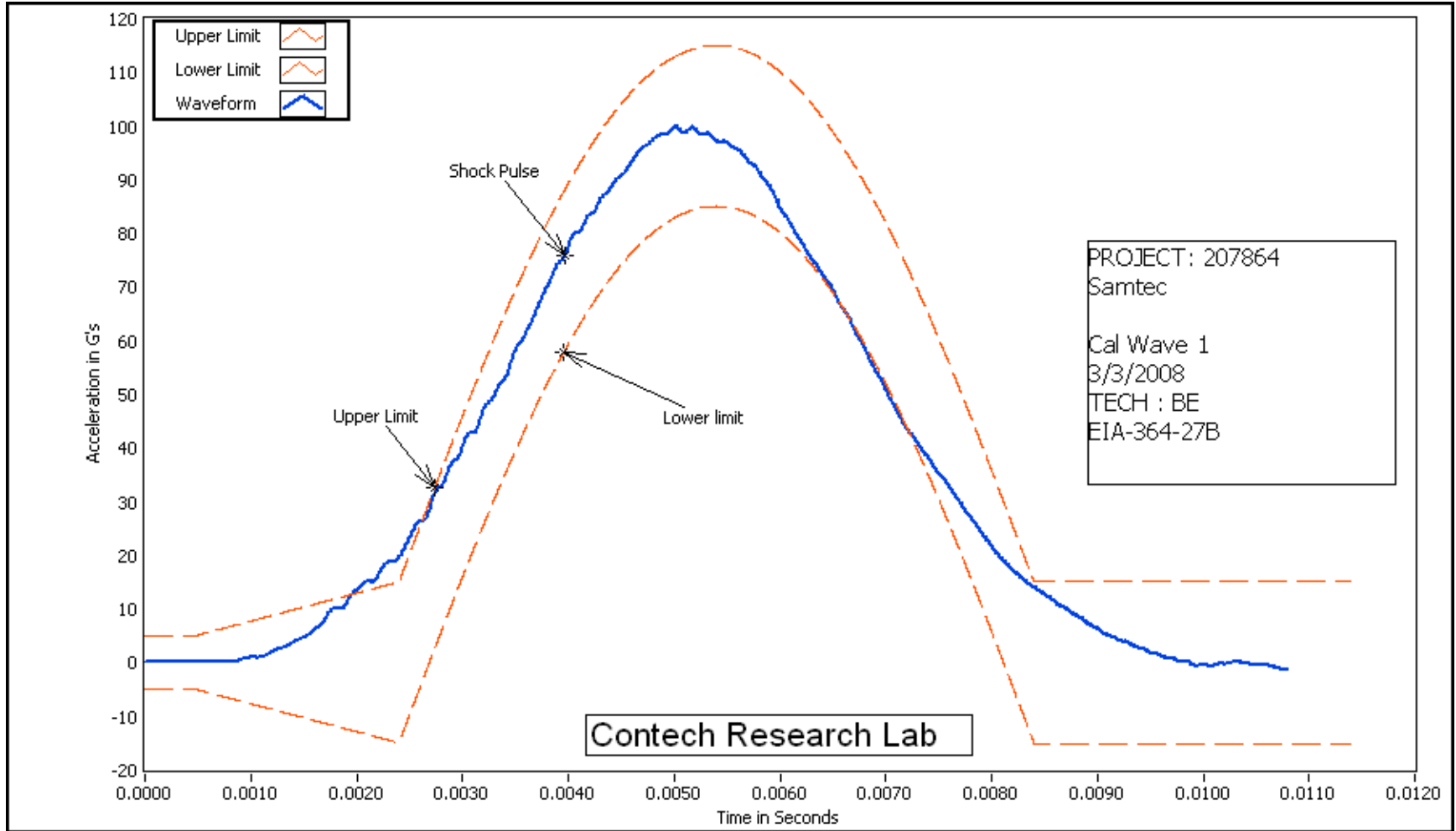
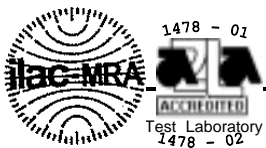
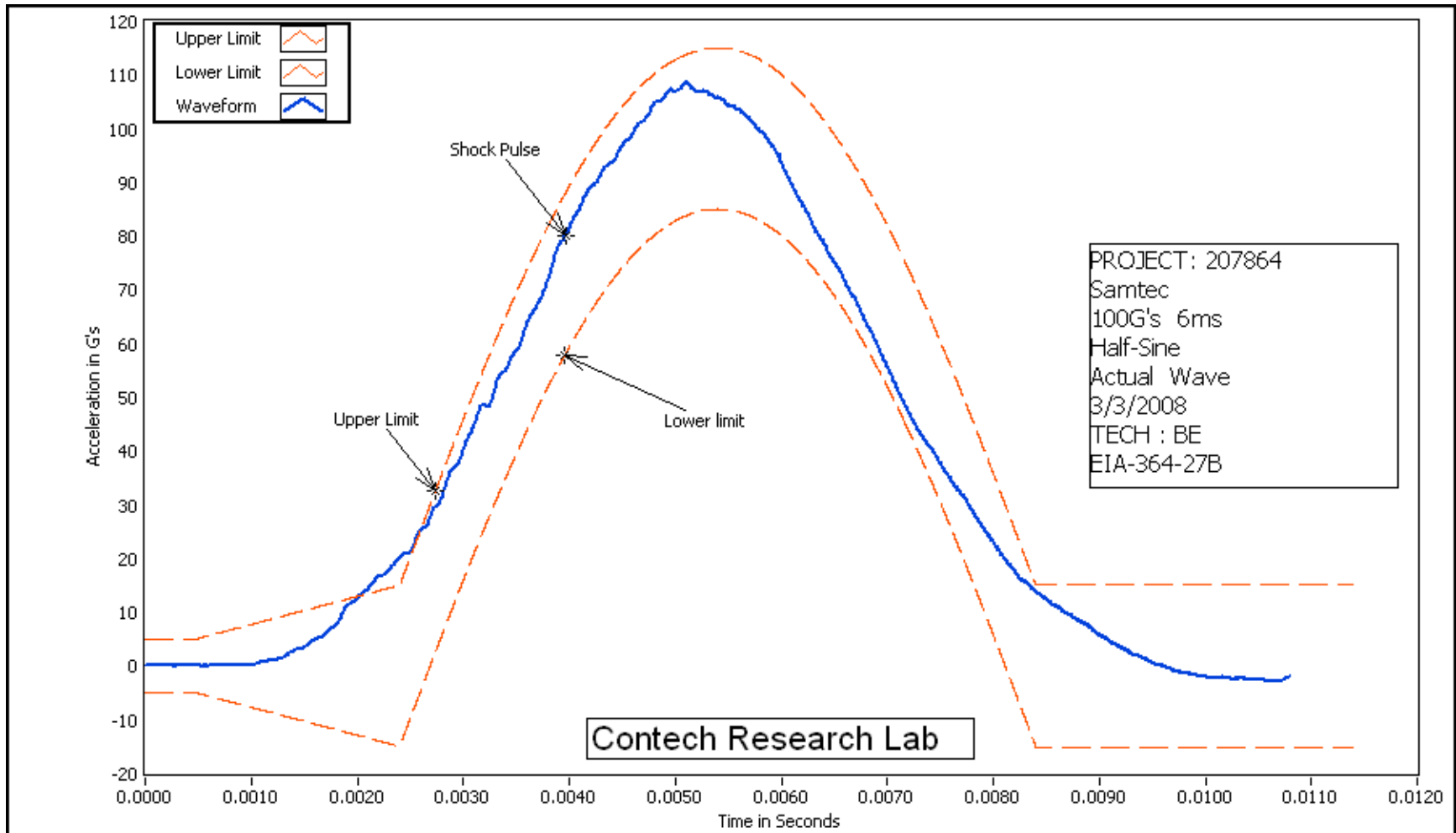

FIGURE #5



PROJECT NO.: 207864

SPECIFICATION: TC073-1549

PART NO.: SEM-125-02-03.0-H-D-WT PART DESCRIPTION: SEM/TEM
TEM-125-02-03.0-H-D-WT Conn.

SAMPLE SIZE: 8 Samples

TECHNICIAN: BE

START DATE: 12/13/08

COMPLETE DATE: 12/17/08

ROOM AMBIENT: 22°C

RELATIVE HUMIDITY: 20%

EQUIPMENT ID#: 14, 33, 86, 991, 1243, 1438, 1439, 1440

VIBRATION, RANDOM

PURPOSE:

1. To establish the mechanical integrity of the test samples exposed to external mechanical stresses.
2. To determine if the contact system is susceptible to fretting corrosion.
3. To determine if the electrical stability of the system has degraded when exposed to a vibratory environment.

PROCEDURE:

1. The test was performed in accordance with EIA 364, Test Procedure 28, Test Condition V, Letter B.
2. Test Conditions:
 - a) G 'RMS' : 7.56
 - b) Frequency : 50 to 2000 Hz
 - c) Duration : 2.0 hours per axis, 3 axis total
3. Figure #6 illustrates the test sample fixturing utilized during the test.
4. All subsequent variable testing was performed in accordance with procedures previously indicated.

REQUIREMENTS: See Next Page

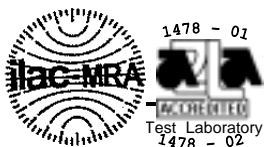

REQUIREMENTS:

1. There shall be no evidence of physical damage to the test samples as tested.
2. The change in low level circuit resistance shall not exceed +10.0 milliohms.

RESULTS:

1. There was no evidence of physical damage to the test samples as tested.
2. The following is a summary of the observed data:

CHANGE IN
LOW LEVEL CIRCUIT RESISTANCE
(Milliohms)

<u>Sample ID#</u>	<u>Avg. Change</u>	<u>Max. Change</u>
B-A-1	-0.9	+4.0
B-A-2	+0.0	+5.8
B-A-3	+0.1	+1.3
B-A-4	+3.1	+9.4
B-A-5	-0.1	+3.0
B-A-6	-0.6	+1.1
B-A-7	-0.8	+5.0
B-A-8	+0.5	+4.2
B-A-9	+0.6	+4.4
B-A-10	-0.3	+1.1

3. See data files 20786409 through 20786416 for individual data points.

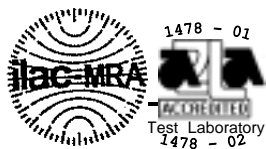
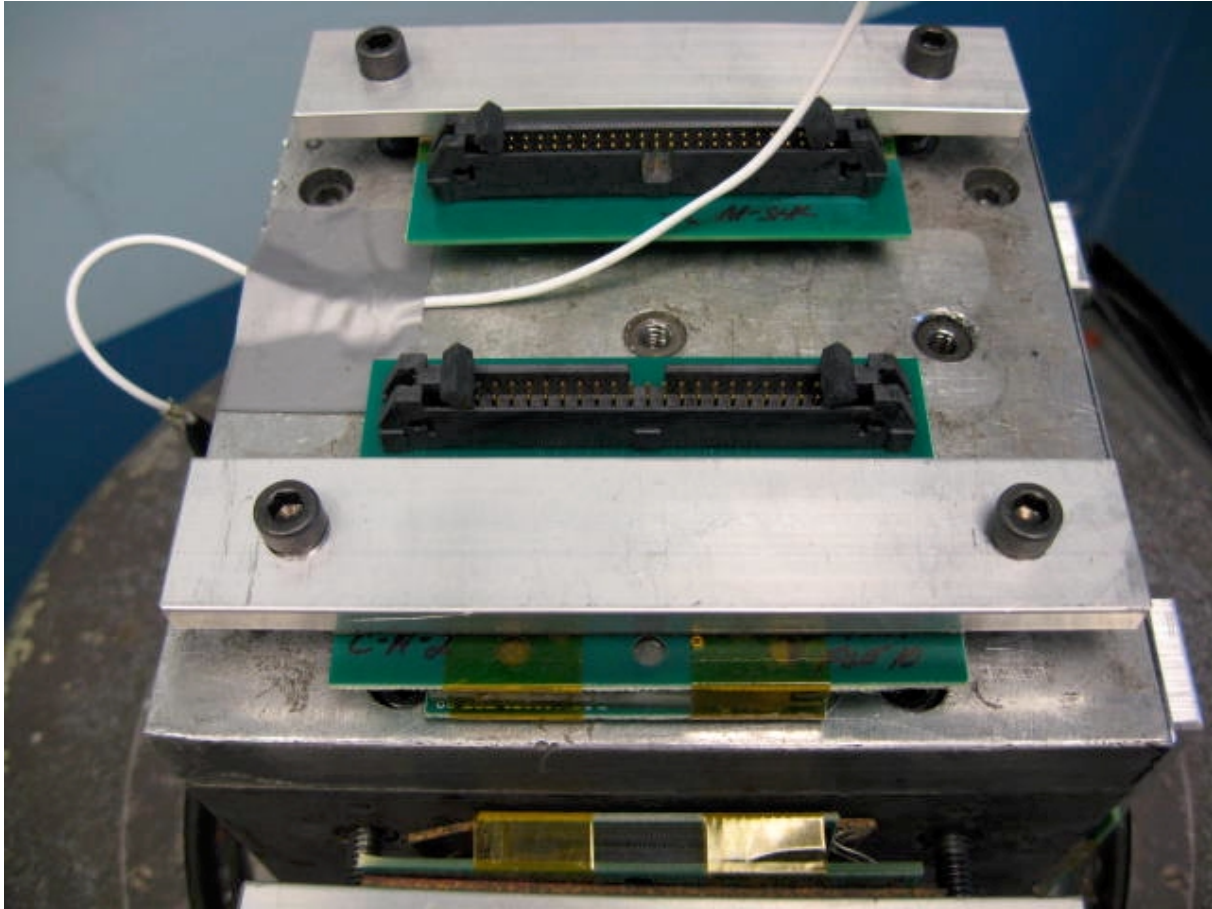

FIGURE #6



LLCR DATA FILES

DATA FILE NUMBERS

20786409

20786410

20786411

20786412

20786413

20786414

20786415

20786416

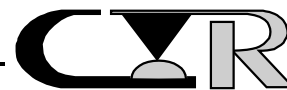
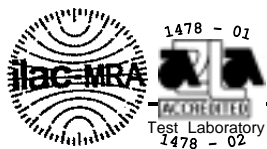

Low Level Contact Resistance				
Project:	207864			Spec: EIA 364, TP 23
Customer:	Samtec			Subgroup: Seq c
Product:	Series SEM/TEM connector			File #: 20786409
Description:	C-A-1			
Open circuit voltage:	20mv			Current: 10ma
		Delta values		
		units: milliohms		
Temp °C	23	22	22	
R.H. %	20	27	25	
Date:	25Feb08	05Mar08	06Mar08	
Pos. ID	Initial	M-Shock	Vibration	
1	9.2	-0.2	-0.4	
2	9.4	0.0	-0.1	
3	9.3	-0.1	-0.2	
4	9.6	-0.2	-0.2	
5	9.4	0.0	0.0	
6	9.8	-0.2	-0.2	
7	9.6	-0.2	-0.1	
8	9.3	0.3	0.3	
9	9.5	-0.1	-0.1	
10	9.9	-0.4	0.0	
11	9.4	0.1	-0.3	
12	9.8	-0.4	-0.2	
13	9.7	-0.1	-0.3	
14	9.7	0.3	0.2	
15	9.8	0.7	0.3	
16	9.5	0.2	0.3	
17	9.0	0.1	0.2	
18	9.4	0.1	0.1	
19	9.5	-0.4	-0.3	
20	10.0	-0.3	-0.3	
21	10.3	-0.1	0.1	
22	9.7	0.1	0.1	
23	9.9	-0.2	0.1	
24	9.7	-0.1	0.0	
25	9.4	0.0	0.1	
MAX	10.3	0.7	0.3	
MIN	9.0	-0.4	-0.4	
AVG	9.6	0.0	0.0	
STD	0.3	0.3	0.2	
Open	0	0	0	
Tech	JG	BE	BE	
Equip ID	1512	601	601	
	295	677	677	

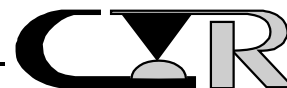
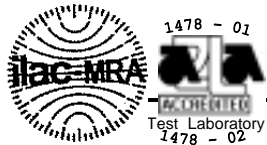

Contech Research

An Independent Test and Research Laboratory

Low Level Contact Resistance				
Project:	207864			Spec: EIA 364, TP 23
Customer:	Samtec			Subgroup: Seq c
Product:	Series SEM/TEM connector			File #: 20786410
Description:	C-A-2			
Open circuit voltage:	20mv			Current: 10ma
			Delta values	
			units: milliohms	
Temp °C	23	22	22	
R.H. %	20	27	25	
Date:	25Feb08	05Mar08	06Mar08	
Pos. ID	Initial	M-Shock	Vibration	
1	9.5	0.9	0.5	
2	9.4	0.7	0.6	
3	9.2	0.2	0.2	
4	9.6	0.2	0.1	
5	9.3	0.3	0.3	
6	9.6	0.6	0.3	
7	8.9	0.4	0.5	
8	9.2	0.9	0.6	
9	8.9	1.1	0.9	
10	9.3	0.8	0.5	
11	9.0	1.0	0.7	
12	9.2	0.8	0.2	
13	9.4	1.0	0.1	
14	9.5	0.4	0.0	
15	9.5	0.1	0.2	
16	9.5	0.8	0.0	
17	9.6	0.3	-0.2	
18	9.1	0.6	0.0	
19	8.9	0.7	0.3	
20	9.8	-0.2	0.2	
21	9.7	-0.3	0.2	
22	9.8	0.0	0.3	
23	9.6	0.0	0.0	
24	10.2	-0.9	-0.4	
25	9.2	-0.2	0.3	
MAX	10.2	1.1	0.9	
MIN	8.9	-0.9	-0.4	
AVG	9.4	0.4	0.2	
STD	0.3	0.5	0.3	
Open	0	0	0	
Tech	JG	BE	BE	
Equip ID	1512	601	601	
	295	677	677	

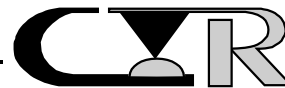
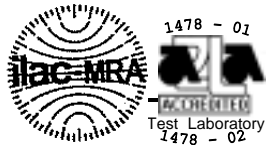

Contech Research

An Independent Test and Research Laboratory

Low Level Contact Resistance				
Project:	207864			Spec: EIA 364, TP 23
Customer:	Samtec			Subgroup: Seq c
Product:	Series SEM/TEM connector			File #: 20786411
Description:	C-A-3			
Open circuit voltage:	20mv			Current: 10ma
		Delta values		
		units: milliohms		
Temp °C	23	22	22	
R.H. %	20	27	25	
Date:	25Feb08	05Mar08	06Mar08	
Pos. ID	Initial	M-Shock	Vibration	
1	9.1	0.0	-0.4	
2	9.2	0.3	-0.2	
3	9.6	0.0	-0.6	
4	9.3	0.8	0.0	
5	9.6	1.2	0.7	
6	9.5	0.8	0.1	
7	9.3	0.4	-0.2	
8	9.5	0.2	0.2	
9	9.7	1.4	0.2	
10	10.1	1.8	0.8	
11	9.5	1.2	0.5	
12	9.9	1.3	1.0	
13	9.6	0.9	0.7	
14	9.5	0.8	0.9	
15	9.6	1.3	1.7	
16	9.8	1.0	0.4	
17	9.2	0.9	0.1	
18	9.5	0.0	-0.5	
19	9.0	0.0	0.0	
20	9.5	-0.2	0.4	
21	9.7	-0.2	0.3	
22	9.8	-0.1	0.1	
23	9.8	-0.1	-0.2	
24	9.6	0.2	-0.6	
25	9.2	-0.1	-0.3	
MAX	10.1	1.8	1.7	
MIN	9.0	-0.2	-0.6	
AVG	9.5	0.6	0.2	
STD	0.3	0.6	0.5	
Open	0	0	0	
Tech	JG	BE	BE	
Equip ID	1512	601	601	
	295	677	677	

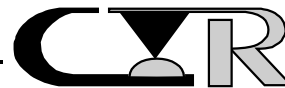
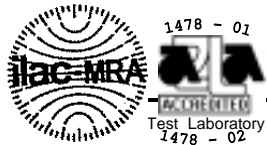

Contech Research

An Independent Test and Research Laboratory

Low Level Contact Resistance				
Project:	207864			Spec: EIA 364, TP 23
Customer:	Samtec			Subgroup: Seq c
Product:	Series SEM/TEM connector			File #: 20786412
Description:	C-A-4			
Open circuit voltage:	20mv			Current: 10ma
		Delta values		
		units: milliohms		
Temp °C	23	22	22	
R.H. %	20	27	25	
Date:	25Feb08	05Mar08	06Mar08	
Pos. ID	Initial	M-Shock	Vibration	
1	8.8	0.3	0.1	
2	8.9	-0.1	-0.1	
3	9.4	-0.3	-0.4	
4	9.2	-0.2	-0.2	
5	9.0	-0.1	0.0	
6	9.2	0.1	-0.3	
7	9.1	-0.1	-0.4	
8	9.2	0.2	-0.4	
9	9.1	0.3	-0.1	
10	9.1	-0.1	-0.3	
11	9.4	0.1	0.0	
12	9.2	-0.1	-0.2	
13	9.6	-0.2	-0.1	
14	9.3	0.3	0.1	
15	9.2	-0.3	-0.3	
16	9.0	0.1	-0.2	
17	9.6	-0.1	-0.1	
18	9.3	0.3	0.3	
19	8.9	-0.2	-0.2	
20	9.3	0.4	0.2	
21	9.0	0.3	0.4	
22	9.7	-0.1	0.1	
23	9.7	0.0	0.0	
24	9.3	0.1	0.3	
25	9.5	-0.2	-0.5	
MAX	9.7	0.4	0.4	
MIN	8.8	-0.3	-0.5	
AVG	9.2	0.0	-0.1	
STD	0.2	0.2	0.2	
Open	0	0	0	
Tech	JG	BE	BE	
Equip ID	1512	601	601	
	295	677	677	

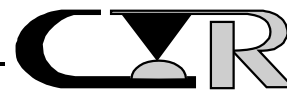
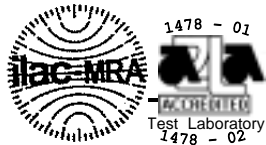

Contech Research

An Independent Test and Research Laboratory

Low Level Contact Resistance				
Project:	207864			Spec: EIA 364, TP 23
Customer:	Samtec			Subgroup: Seq c
Product:	Series SEM/TEM connector			File #: 20786413
Description:	C-A-5			
Open circuit voltage:	20mv			Current: 10ma
		Delta values		
		units: milliohms		
Temp °C	23	22	22	
R.H. %	20	27	25	
Date:	25Feb08	05Mar08	06Mar08	
Pos. ID	Initial	M-Shock	Vibration	
1	10.1	-0.6	-1.3	
2	10.1	0.1	-0.6	
3	9.9	-0.1	-0.8	
4	10.6	-0.2	-1.1	
5	10.4	0.0	-1.2	
6	10.1	0.3	-0.8	
7	9.6	0.0	-0.6	
8	10.1	0.0	-0.7	
9	10.2	-0.5	-0.7	
10	10.1	-0.2	-0.4	
11	10.0	-0.2	-0.8	
12	10.1	-0.3	-0.8	
13	10.0	0.1	-0.6	
14	10.6	-0.4	0.2	
15	10.3	-0.4	0.3	
16	10.6	-0.7	-0.6	
17	9.6	-0.4	-0.1	
18	9.5	-0.5	0.2	
19	9.0	-0.1	-0.1	
20	10.2	-0.4	-0.1	
21	10.4	-0.5	-0.4	
22	11.3	-0.4	-0.6	
23	9.7	0.4	0.3	
24	10.3	-0.5	-0.1	
25	9.1	0.2	0.3	
MAX	11.3	0.4	0.3	
MIN	9.0	-0.7	-1.3	
AVG	10.1	-0.2	-0.4	
STD	0.5	0.3	0.5	
Open	0	0	0	
Tech	JG	BE	BE	
Equip ID	1512	601	601	
	295	677	677	

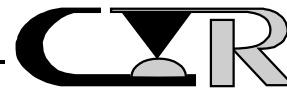
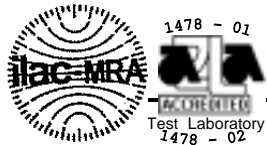

Contech Research

An Independent Test and Research Laboratory

Low Level Contact Resistance				
Project:	207864			Spec: EIA 364, TP 23
Customer:	Samtec			Subgroup: Seq c
Product:	Series SEM/TEM connector			File #: 20786414
Description:	C-A-6			
Open circuit voltage:	20mv			Current: 10ma
		Delta values		
		units: milliohms		
Temp °C	23	22	22	
R.H. %	20	27	25	
Date:	25Feb08	05Mar08	06Mar08	
Pos. ID	Initial	M-Shock	Vibration	
1	8.7	0.7	0.8	
2	9.2	0.4	0.4	
3	9.1	0.3	0.5	
4	9.5	0.5	0.4	
5	9.2	0.8	1.0	
6	9.3	1.4	0.8	
7	8.9	0.7	0.6	
8	9.4	0.7	0.7	
9	9.0	0.4	0.3	
10	9.3	0.4	0.3	
11	9.1	0.4	0.5	
12	9.7	0.1	0.3	
13	9.6	0.3	-0.2	
14	9.3	0.4	0.4	
15	9.3	0.6	0.7	
16	9.2	0.3	0.5	
17	9.1	0.4	0.2	
18	9.1	0.5	0.7	
19	9.0	0.7	1.0	
20	9.5	0.6	3.3	
21	10.7	0.2	1.3	
22	9.3	0.5	1.1	
23	9.3	0.7	0.2	
24	9.1	0.4	0.1	
25	8.9	0.6	0.6	
MAX	10.7	1.4	3.3	
MIN	8.7	0.1	-0.2	
AVG	9.3	0.5	0.7	
STD	0.4	0.3	0.6	
Open	0	0	0	
Tech	JG	BE	BE	
Equip ID	1512	601	601	
	295	677	677	

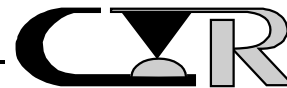
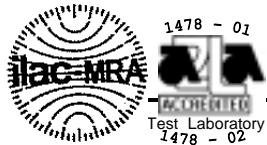

Contech Research

An Independent Test and Research Laboratory

Low Level Contact Resistance				
Project:	207864			Spec: EIA 364, TP 23
Customer:	Samtec			Subgroup: Seq c
Product:	Series SEM/TEM connector			File #: 20786415
Description:	C-A-7			
Open circuit voltage:	20mv			Current: 10ma
		Delta values		
		units: milliohms		
Temp °C	23	22	22	
R.H. %	20	27	25	
Date:	25Feb08	05Mar08	06Mar08	
Pos. ID	Initial	M-Shock	Vibration	
1	8.7	0.1	0.1	
2	8.8	0.1	-0.2	
3	9.0	-0.2	0.0	
4	8.8	0.1	0.1	
5	8.9	0.0	0.1	
6	9.2	-0.3	0.1	
7	8.7	0.1	0.3	
8	8.9	0.4	0.6	
9	9.2	-0.4	-0.2	
10	9.2	-0.1	0.4	
11	9.2	0.1	0.0	
12	9.0	0.5	1.0	
13	9.1	0.0	0.4	
14	9.1	-0.3	0.0	
15	9.2	0.0	-0.1	
16	9.5	-0.5	-0.7	
17	9.9	-0.2	-0.8	
18	9.3	0.5	-0.4	
19	9.2	0.0	-0.3	
20	8.9	0.1	0.1	
21	9.1	-0.2	-0.1	
22	9.4	-0.4	-0.1	
23	9.7	-0.4	0.0	
24	8.9	0.4	0.1	
25	9.5	0.1	-0.1	
MAX	9.9	0.5	1.0	
MIN	8.7	-0.5	-0.8	
AVG	9.1	0.0	0.0	
STD	0.3	0.3	0.4	
Open	0	0	0	
Tech	JG	BE	BE	
Equip ID	1512	601	601	
	295	677	677	

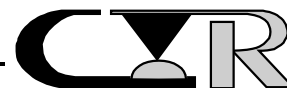
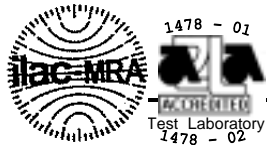

Contech Research

An Independent Test and Research Laboratory

Low Level Contact Resistance				
Project:	207864			Spec: EIA 364, TP 23
Customer:	Samtec			Subgroup: Seq c
Product:	Series SEM/TEM connector			File #: 20786416
Description:	C-A-8			
Open circuit voltage:	20mv			Current: 10ma
		Delta values		
		units: milliohms		
Temp °C	23	22	22	
R.H. %	20	27	25	
Date:	25Feb08	05Mar08	06Mar08	
Pos. ID	Initial	M-Shock	Vibration	
1	9.5	-0.3	-0.5	
2	10.1	-0.5	-0.2	
3	9.9	-0.5	-0.3	
4	9.9	-0.3	-0.4	
5	9.6	-0.4	-0.3	
6	9.7	-0.2	-0.2	
7	8.9	-0.4	-0.2	
8	9.2	-0.1	0.3	
9	9.2	-0.2	-0.3	
10	9.4	-0.2	0.0	
11	9.2	-0.3	-0.4	
12	9.0	0.2	0.2	
13	9.3	-0.1	0.0	
14	9.5	-0.2	-0.3	
15	9.4	-0.1	-0.1	
16	9.6	0.0	-0.3	
17	10.0	-0.5	-0.7	
18	9.1	0.1	-0.2	
19	9.2	-0.1	-0.4	
20	9.4	-0.2	-0.3	
21	9.6	0.3	0.1	
22	9.9	0.3	-0.1	
23	10.1	-0.6	-0.8	
24	9.4	0.0	-0.3	
25	9.3	0.0	-0.1	
MAX	10.1	0.3	0.3	
MIN	8.9	-0.6	-0.8	
AVG	9.5	-0.2	-0.2	
STD	0.3	0.2	0.2	
Open	0	0	0	
Tech	JG	BE	BE	
Equip ID	1512	601	601	
	295	677	677	

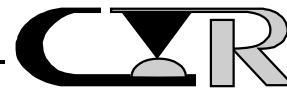
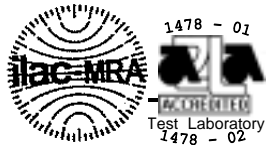

Contech Research

An Independent Test and Research Laboratory

TEST RESULTS

SEQUENCE D

Group A

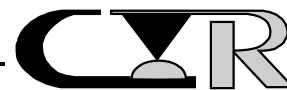
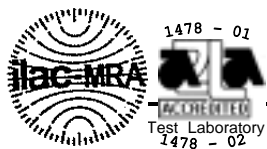

PROJECT NO.: 207864

SPECIFICATION: TC073-1549

PART NO.: SEM-125-02-03.0-H-D-WT PART DESCRIPTION: SEM/TEM
TEM-125-02-03.0-H-D-WT Conn.

SAMPLE SIZE: 3 Samples

TECHNICIAN: BE

START DATE: 3/5/08

COMPLETE DATE: 3/5/08

ROOM AMBIENT: 23°C

RELATIVE HUMIDITY: 18%

EQUIPMENT ID#: 14, 34, 1543

PURPOSE:

To determine the mechanical and electrical integrity of connectors for use with electronic equipment subjected to shocks such as those expected from handling, transportation, etc.

PROCEDURE:

1. The test was performed in accordance with EIA 364, Test Procedure 27.
2. Test Conditions:
 - a) Peak Value : 100 G
 - b) Duration : 6 Milliseconds
 - c) Wave Form : Half-Sine
 - d) Velocity : 12.3 feet Per Second
 - e) No. of Shocks : 3 Shocks/Direction, 3 Axis (18 Total)
3. A stabilizing medium was used such that the mated test samples did not separate during the test.
4. Figure #6 illustrates the test sample fixturing utilized during the test.
5. The samples were characterized to determine nanosecond event requirement. Following characterization the requirement level was established at 50 nanoseconds.
5. The low nanosecond monitoring was performed in accordance with EIA 364, Test Procedure 87.

REQUIREMENTS: See next page.

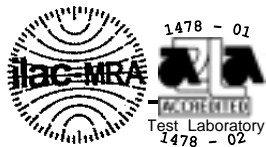

REQUIREMENTS:

1. There shall be no evidence of physical damage to the test samples as tested.
2. There shall be no low nanosecond event detected greater than 50 nanoseconds.

RESULTS:

1. There was no evidence of physical damage to the test samples as tested.
2. There was no low nanosecond event detected greater than 50 nanoseconds.
3. The Mechanical Shock characteristics are shown in Figures #7 (Calibration Pulse) and #8 (Test Pulse). Each figure displays the shock pulse contained within the upper and lower limits as defined by the appropriate test specification.

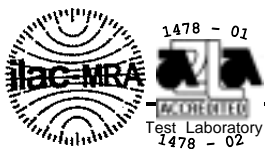

FIGURE #7

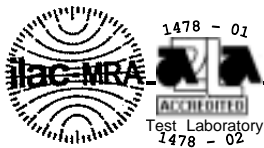
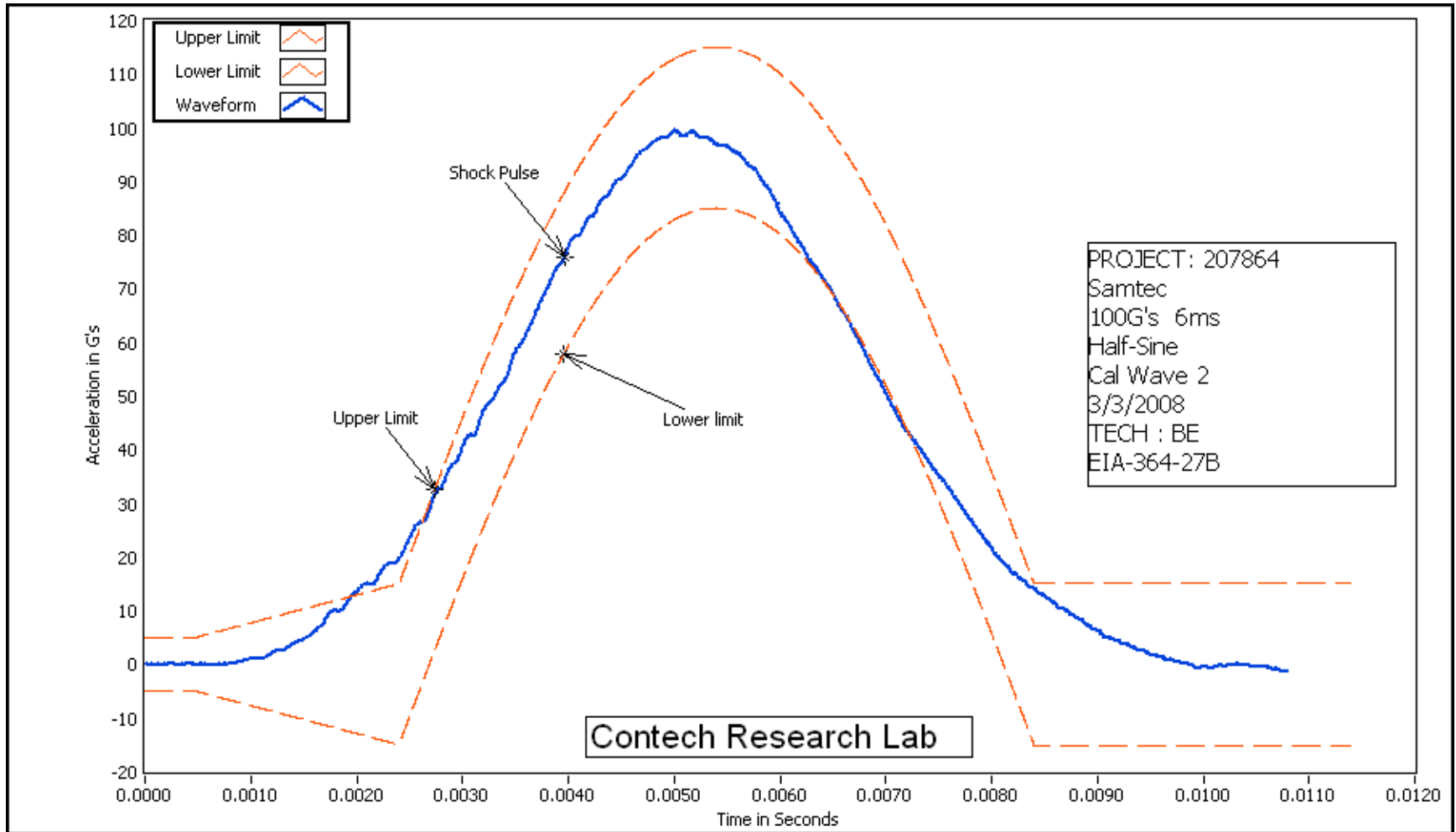
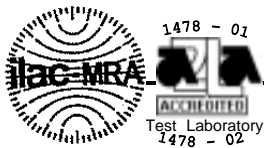
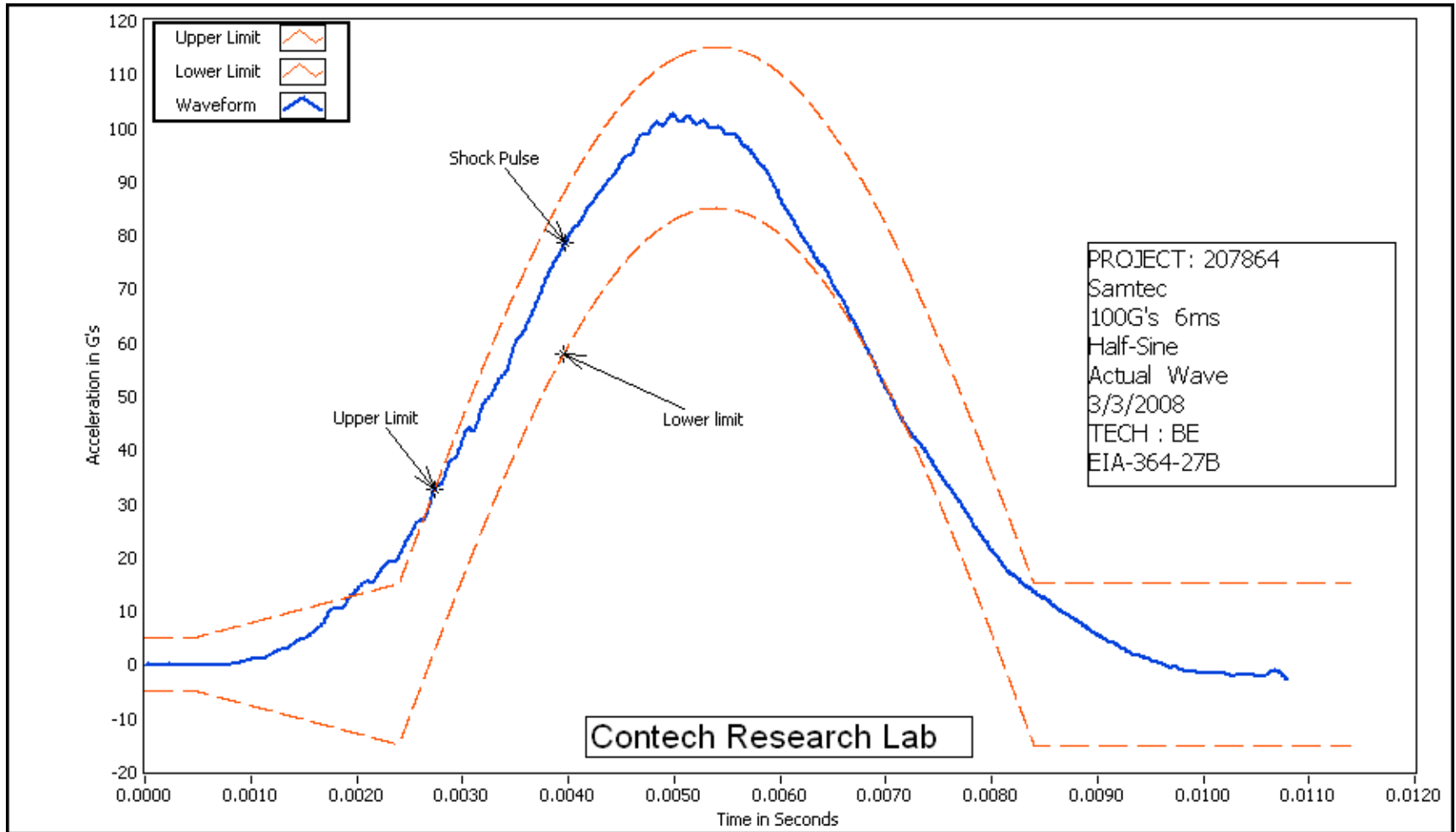

FIGURE #8



PROJECT NO.: 207864

SPECIFICATION: TC073-1549

PART NO.: SEM-125-02-03.0-H-D-WT PART DESCRIPTION: SEM/TEM
TEM-125-02-03.0-H-D-WT Conn.

SAMPLE SIZE: 3 Samples

TECHNICIAN: BE

START DATE: 3/5/08

COMPLETE DATE: 3/6/08

ROOM AMBIENT: 22°C

RELATIVE HUMIDITY: 27%

EQUIPMENT ID#: 14, 33, 86, 991, 1243, 1438, 1439, 1440

VIBRATION, RANDOM

PURPOSE:

1. To establish the mechanical integrity of the test samples exposed to external mechanical stresses.
2. To determine if the contact system is susceptible to fretting corrosion.
3. To determine if electrical discontinuities at the level specified exist.

PROCEDURE:

1. The test was performed in accordance with Specification EIA 364, Test Procedure 28, Test Condition V, Letter B.
2. Test Conditions:
 - a) G 'RMS' : 7.56
 - b) Frequency : 50 to 2000 Hz
 - c) Duration : 2.0 Hours per Axis, 3 Axis Total
 - d) Test Current : 100 mA
3. A stabilizing medium was used such that the mated test samples did not separate during the test.
4. Figure #6 illustrates the test sample fixturing utilized during the test.
5. The samples were characterized prior to test to determine nanosecond event requirement. Following characterization the requirement level was established at 50 nanoseconds.

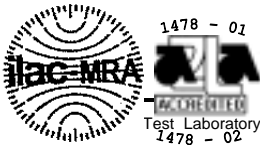

PROCEDURE: -continued

6. The low nanosecond monitoring was performed in accordance with EIA 364, Test Procedure 87.

REQUIREMENTS:

1. There shall be no evidence of physical damage to the test samples as tested.
2. There shall be no low nanosecond event detected greater than 50 nanoseconds.

RESULTS:

1. There was no evidence of physical damage to the test samples as tested.
2. There was no low nanosecond event detected greater than 50 nanoseconds.

