

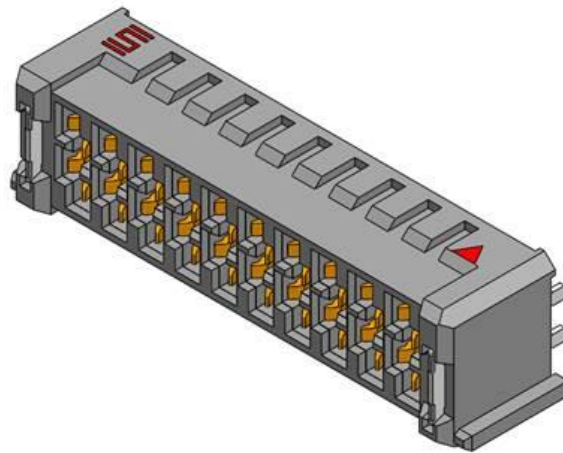

Project Number: Design Qualification Test Report	Tracking Code: 2410700_Report_Rev_2
Requested by: Leo Lee	Date: 6/11/2024
Part #: UMPS-04-05.5-G-V-S-W-TR/ UMPT-04-01-L-RA-WT-TR	Tech: Peter Chen
Part description: UMPS/UMPT	Qty to test: 32
Test Start: 05/20/2020	Test Completed: 06/15/2020

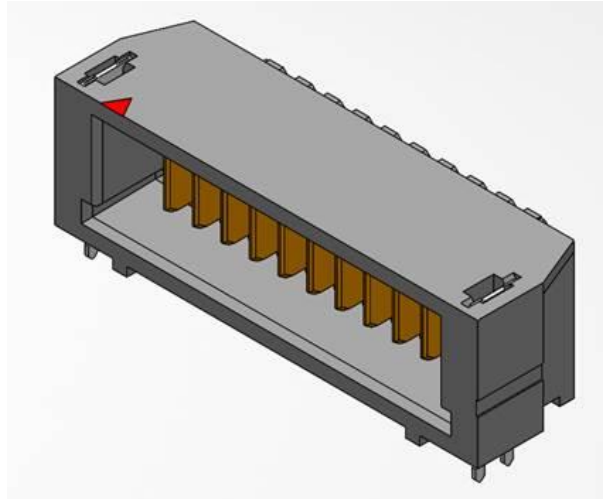

## DESIGN QUALIFICATION TEST REPORT

UMPS / UMPT

UMPS-04-05.5-G-V-S-W-TR/ UMPT-04-01-L-RA-WT-TR

Tracking Code: 2410700_Report_Rev_2	Part #: UMPS-04-05.5-G-V-S-W-TR/ UMPT-04-01-L-RA-WT-TR
Part description: UMPS / UMPT	

**REVISION HISTORY**

<b>DATA</b>	<b>REV.NUM.</b>	<b>DESCRIPTION</b>	<b>ENG</b>
08/06/2020	1	Initial Issue	PC
08/11/2022	2	Updated the part number	PC

## CERTIFICATION

All instruments and measuring equipment were calibrated to National Institute for Standards and Technology (NIST) traceable standards according to ISO 10012-1 and ANSI/NCSL 2540-1, as applicable.

All contents contained herein are the property of Samtec. No portion of this report, in part or in full shall be reproduced without prior written approval of Samtec.

### SCOPE

To perform the following tests: Design Qualification test. Please see test plan.

### APPLICABLE DOCUMENTS

Standards: EIA Publication 364

### TEST SAMPLES AND PREPARATION

- 1) All materials were manufactured in accordance with the applicable product specification.
- 2) All test samples were identified and encoded to maintain traceability throughout the test sequences.
- 3) After soldering, the parts to be used for LLCR and DWV/IR testing were cleaned according to TLWI-0001.
- 4) Either an automated cleaning procedure or an ultrasonic cleaning procedure may be used.
- 5) The automated procedure is used with aqueous compatible soldering materials.
- 6) Parts not intended for testing LLCR and DWV/IR are visually inspected and cleaned if necessary.
- 7) Any additional preparation will be noted in the individual test sequences.
- 8) Solder Information: Lead free
- 9) Samtec Test PCBs used: PCB-110876-TST. PCB-110859-TST.

**FLOWCHARTS****Mating/Unmating/Durability****Group 1**

UMPS-04-05.5-G-V-S-W-TR  
UMPT-04-01-L-RA-WT-TR  
8 Assemblies

Step	Description
1.	Contact Gaps
2.	LLCR <sup>(2)</sup>
3.	Mating/Unmating Force <sup>(3)</sup>
4.	Cycles Quantity = 25 Cycles
5.	Mating/Unmating Force <sup>(3)</sup>
6.	Cycles Quantity = 25 Cycles
7.	Mating/Unmating Force <sup>(3)</sup>
8.	Cycles Quantity = 25 Cycles
9.	Mating/Unmating Force <sup>(3)</sup>
10.	Cycles Quantity = 25 Cycles
11.	Mating/Unmating Force <sup>(3)</sup>
12.	Contact Gaps
13.	LLCR <sup>(2)</sup> Max Delta = 15 mOhm
14.	Thermal Shock <sup>(4)</sup>
15.	LLCR <sup>(2)</sup> Max Delta = 15 mOhm
16.	Humidity <sup>(1)</sup>
17.	LLCR <sup>(2)</sup> Max Delta = 15 mOhm
18.	Mating/Unmating Force <sup>(3)</sup>

**Group 2**

UMPS-02-05.5-G-V-S-W-TR  
UMPT-02-01-L-RA-WT-TR  
8 Assemblies

Step	Description
1.	Contact Gaps
2.	Mating/Unmating Force <sup>(3)</sup>
3.	Cycles Quantity = 25 Cycles
4.	Mating/Unmating Force <sup>(3)</sup>
5.	Cycles Quantity = 25 Cycles
6.	Mating/Unmating Force <sup>(3)</sup>
7.	Cycles Quantity = 25 Cycles
8.	Mating/Unmating Force <sup>(3)</sup>
9.	Cycles Quantity = 25 Cycles
10.	Mating/Unmating Force <sup>(3)</sup>

**Group 3**

UMPS-10-05.5-G-V-S-W-TR  
UMPT-10-01-L-RA-WT-TR  
8 Assemblies

Step	Description
1.	Contact Gaps
2.	Mating/Unmating Force <sup>(3)</sup>
3.	Cycles Quantity = 25 Cycles
4.	Mating/Unmating Force <sup>(3)</sup>
5.	Cycles Quantity = 25 Cycles
6.	Mating/Unmating Force <sup>(3)</sup>
7.	Cycles Quantity = 25 Cycles
8.	Mating/Unmating Force <sup>(3)</sup>
9.	Cycles Quantity = 25 Cycles
10.	Mating/Unmating Force <sup>(3)</sup>

**(1) Humidity = EIA-364-31**

Test Condition = B (240 Hours)

Test Method = III (+25°C to +65°C @ 90% RH to 98% RH)

Test Exceptions: ambient pre-condition and delete steps 7a and 7b

**(2) LLCR = EIA-364-23**

Open Circuit Voltage = 20 mV Max

Test Current = 100 mA Max

**(3) Mating/Unmating Force = EIA-364-13****(4) Thermal Shock = EIA-364-32**

Exposure Time at Temperature Extremes = 1/2 Hour

Method A, Test Condition = I (-55°C to +85°C)

Test Duration = A-3 (100 Cycles)

## FLOWCHARTS Continued

### Current Carrying Capacity

Group 1  
 UMPS-10-05.5-G-V-S-W-TR  
 UMPT-10-01-L-RA-WT-TR  
 1 Pins Powered  
 Power

Step	Description
1.	CCC <sup>(1)</sup> Rows = 1 Number of Positions = 1

Group 2  
 UMPS-10-05.5-G-V-S-W-TR  
 UMPT-10-01-L-RA-WT-TR  
 2 Pins Powered  
 Power

Step	Description
1.	CCC <sup>(1)</sup> Rows = 1 Number of Positions = 2

Group 3  
 UMPS-10-05.5-G-V-S-W-TR  
 UMPT-10-01-L-RA-WT-TR  
 3 Pins Powered  
 Power

Step	Description
1.	CCC <sup>(1)</sup> Rows = 1 Number of Positions = 3

Group 4  
 UMPS-10-05.5-G-V-S-W-TR  
 UMPT-10-01-L-RA-WT-TR  
 4 Pins Powered  
 Power

Step	Description
1.	CCC <sup>(1)</sup> Rows = 1 Number of Positions = 4

---

Group 5  
 UMPS-10-05.5-G-V-S-W-TR  
 UMPT-10-01-L-RA-WT-TR  
 10 Pins Powered  
 Power

Step	Description
1.	CCC <sup>(1)</sup> Rows = 1 Number of Positions = 10

---

(1) CCC = EIA-364-70  
 Method 2, Temperature Rise Versus Current Curve  
 (TIN PLATING) - Tabulate calculated current at RT, 65°C, 75°C and 95°C after derating 20% and based on 105°C  
 (GOLD PLATING) - Tabulate calculated current at RT, 85°C, 95°C and 115°C after derating 20% and based on 125°C

## ATTRIBUTE DEFINITIONS

The following is a brief, simplified description of attributes.

### THERMAL SHOCK:

- 1) EIA-364-32, *Thermal Shock (Temperature Cycling) Test Procedure for Electrical Connectors*.
- 2) Test Condition 1: -55°C to +85°C
- 3) Test Time: ½ hour dwell at each temperature extreme
- 4) Number of Cycles: 100
- 5) All test samples are pre-conditioned at ambient.
- 6) All test samples are exposed to environmental stressing in the mated condition.

### HUMIDITY:

- 1) Reference document: EIA-364-31, *Humidity Test Procedure for Electrical Connectors*.
- 2) Test Condition B, 240 Hours.
- 3) Method III, +25° C to + 65° C, 90% to 98% Relative Humidity excluding sub-cycles 7a and 7b.
- 4) All samples are pre-conditioned at ambient.
- 5) All test samples are exposed to environmental stressing in the mated condition.

### MATING/UNMATING:

- 1) Reference document: EIA-364-13, *Mating and Unmating Forces Test Procedure for Electrical Connectors*.
- 2) The full insertion position was to within 0.003” to 0.004” of the plug bottoming out in the receptacle to prevent damage to the system under test.
- 3) One of the mating parts is secured to a floating X-Y table to prevent damage during cycling.

**ATTRIBUTE DEFINITIONS Continued**

The following is a brief, simplified description of attributes.

**TEMPERATURE RISE (Current Carrying Capacity, CCC):**

- 1) EIA-364-70, *Temperature Rise versus Current Test Procedure for Electrical Connectors and Sockets*.
- 2) When current passes through a contact, the temperature of the contact increases as a result of  $I^2R$  (resistive) heating.
- 3) The number of contacts being investigated plays a significant part in power dissipation and therefore temperature rise.
- 4) The size of the temperature probe can affect the measured temperature.
- 5) Copper traces on PC boards will contribute to temperature rise:
  - a. Self heating (resistive)
  - b. Reduction in heat sink capacity affecting the heated contacts
- 6) A de-rating curve, usually 20%, is calculated.
- 7) Calculated de-rated currents at four temperature points are reported:
  - a. Ambient
  - b. 85° C
  - c. 95° C
  - d. 115° C
- 8) Typically, neighboring contacts (in close proximity to maximize heat build up) are energized.
- 9) The thermocouple (or temperature measuring probe) will be positioned at a location to sense the maximum temperature in the vicinity of the heat generation area.
- 10) A computer program, *TR 803.exe*, ensures accurate stability for data acquisition.
- 11) Hook-up wire cross section is larger than the cross section of any connector leads/PC board traces, jumpers, etc.
- 12) Hook-up wire length is longer than the minimum specified in the referencing standard.

**LLCR:**

- 1) EIA-364-23, *Low Level Contact Resistance Test Procedure for Electrical Connectors and Sockets*.
- 2) A computer program, *LLCR 221.exe*, ensures repeatability for data acquisition.
- 3) The following guidelines are used to categorize the changes in LLCR as a result from stressing
  - a.  $\leq +0.33$  mOhms: -----Stable
  - b.  $+0.33$  to  $+0.66$  mOhms: -----Minor
  - c.  $+0.67$  to  $+1.00$  mOhms: -----Acceptable
  - d.  $+1.01$  to  $+50.0$  mOhms: -----Marginal
  - e.  $+50.1$  to  $+1000$  mOhms: -----Unstable
  - f.  $>+1000$  mOhms:-----Open Failure

## RESULTS

### Temperature Rise, CCC at a 20% de-rating

- CCC for a 30°C Temperature Rise-----18.1 A per contact with 1 contacts (1x1) powered
- CCC for a 30°C Temperature Rise-----16.6 A per contact with 2 contacts (1x2) powered
- CCC for a 30°C Temperature Rise-----14.0 A per contact with 3 contacts (1x3) powered
- CCC for a 30°C Temperature Rise-----13.5 A per contact with 4 contacts (1x4) powered
- CCC for a 30°C Temperature Rise-----8.9 A per contact with 10 contacts (1x10) powered

### Mating – Unmating Forces

#### Mating-Unmating Durability Group

- **Initial**
  - **Mating**
    - **Min** ----- 3.17 Lbs
    - **Max** ----- 4.01 Lbs
  - **Unmating**
    - **Min** ----- 1.84 Lbs
    - **Max** ----- 2.27 Lbs
- **After 25 Cycles**
  - **Mating**
    - **Min** ----- 3.10 Lbs
    - **Max** ----- 3.78 Lbs
  - **Unmating**
    - **Min** ----- 2.35 Lbs
    - **Max** ----- 2.67 Lbs
- **After 50 Cycles**
  - **Mating**
    - **Min** ----- 2.68 Lbs
    - **Max** ----- 3.01 Lbs
  - **Unmating**
    - **Min** ----- 2.51 Lbs
    - **Max** ----- 2.72 Lbs
- **After 75 Cycles**
  - **Mating**
    - **Min** ----- 2.68 Lbs
    - **Max** ----- 2.93 Lbs
  - **Unmating**
    - **Min** ----- 2.54 Lbs
    - **Max** ----- 2.78 Lbs
- **After 100 Cycles**
  - **Mating**
    - **Min** ----- 2.56 Lbs
    - **Max** ----- 3.01 Lbs
  - **Unmating**
    - **Min** ----- 2.39 Lbs
    - **Max** ----- 2.77 Lbs
- **Humidity**
  - **Mating**
    - **Min** ----- 1.54 Lbs
    - **Max** ----- 1.85 Lbs
  - **Unmating**
    - **Min** ----- 1.44 Lbs
    - **Max** ----- 1.69 Lbs

**RESULTS Continued**

**Mating-Unmating Basic (UMPS-10-05.5-G-V-S-W-TR/ UMPT-10-01-L-RA-WT-TR)**

- **Initial**
  - **Mating**
    - **Min** ----- 9.24 Lbs
    - **Max** ----- 10.94 Lbs
  - **Unmating**
    - **Min** ----- 5.73 Lbs
    - **Max** ----- 6.14 Lbs
- **After 25 Cycles**
  - **Mating**
    - **Min** ----- 8.57 Lbs
    - **Max** ----- 9.91 Lbs
  - **Unmating**
    - **Min** ----- 6.26 Lbs
    - **Max** ----- 6.79 Lbs
- **After 50 Cycles**
  - **Mating**
    - **Min** ----- 7.36 Lbs
    - **Max** ----- 8.31 Lbs
  - **Unmating**
    - **Min** ----- 6.46 Lbs
    - **Max** ----- 7.13 Lbs
- **After 75 Cycles**
  - **Mating**
    - **Min** ----- 3.72 Lbs
    - **Max** ----- 7.51 Lbs
  - **Unmating**
    - **Min** ----- 6.56 Lbs
    - **Max** ----- 7.15 Lbs
- **After 100 Cycles**
  - **Mating**
    - **Min** ----- 7.10 Lbs
    - **Max** ----- 7.67 Lbs
  - **Unmating**
    - **Min** ----- 6.73 Lbs
    - **Max** ----- 7.23 Lbs

**RESULTS Continued****Mating-Unmating Basic (UMPS-02-05.5-G-V-S-W-TR/ UMPT-02-01-L-RA-WT-TR)**

- **Initial**
  - **Mating**
    - **Min** ----- 1.82 Lbs
    - **Max** ----- 2.41 Lbs
  - **Unmating**
    - **Min** ----- 1.25 Lbs
    - **Max** ----- 1.63 Lbs
- **After 25 Cycles**
  - **Mating**
    - **Min** ----- 2.02 Lbs
    - **Max** ----- 2.41 Lbs
  - **Unmating**
    - **Min** ----- 1.47 Lbs
    - **Max** ----- 1.79 Lbs
- **After 50 Cycles**
  - **Mating**
    - **Min** ----- 1.74 Lbs
    - **Max** ----- 2.25 Lbs
  - **Unmating**
    - **Min** ----- 1.63 Lbs
    - **Max** ----- 2.00 Lbs
- **After 75 Cycles**
  - **Mating**
    - **Min** ----- 1.75 Lbs
    - **Max** ----- 2.18 Lbs
  - **Unmating**
    - **Min** ----- 1.73 Lbs
    - **Max** ----- 2.10 Lbs
- **After 100 Cycles**
  - **Mating**
    - **Min** ----- 1.84 Lbs
    - **Max** ----- 2.25 Lbs
  - **Unmating**
    - **Min** ----- 1.78 Lbs
    - **Max** ----- 2.13 Lbs

**RESULTS Continued**

**LLCR Mating/Unmating Durability Group (32 LLCR test points)**

- **Initial -----1.24 mOhms Max**
- **Durability, 100 Cycles**
  - **<= +0.33 mOhms -----32 Points ----- Stable**
  - **+0.34 to +0.66 mOhms -----0 Points ----- Minor**
  - **+0.67 to +1.00 mOhms -----0 Points ----- Acceptable**
  - **+1.01 to +50.0 mOhms -----0 Points ----- Marginal**
  - **+50.1 to +1000 mOhms-----0 Points ----- Unstable**
  - **>+1000 mOhms-----0 Points ----- Open Failure**
- **Thermal Shock**
  - **<= +0.33 mOhms -----32 Points ----- Stable**
  - **+0.34 to +0.66 mOhms -----0 Points ----- Minor**
  - **+0.67 to +1.00 mOhms -----0 Points ----- Acceptable**
  - **+1.01 to +50.0 mOhms -----0 Points ----- Marginal**
  - **+50.1 to +1000 mOhms-----0 Points ----- Unstable**
  - **>+1000 mOhms-----0 Points ----- Open Failure**
- **Humidity**
  - **<= +0.33 mOhms -----32 Points ----- Stable**
  - **+0.34 to +0.66 mOhms -----0 Points ----- Minor**
  - **+0.67 to +1.00 mOhms -----0 Points ----- Acceptable**
  - **+1.01 to +50.0 mOhms -----0 Points ----- Marginal**
  - **+50.1 to +1000 mOhms-----0 Points ----- Unstable**
  - **>+1000 mOhms-----0 Points ----- Open Failure**

### DATA SUMMARIES

#### TEMPERATURE RISE (Current Carrying Capacity, CCC):

- 1) High quality thermocouples whose temperature slopes track one another were used for temperature monitoring.
- 2) The thermocouples were placed at a location to sense the maximum temperature generated during testing.
- 3) Temperature readings recorded are those for which three successive readings, 15 minutes apart, differ less than 1° C (computer controlled data acquisition).
- 4) Adjacent contacts were powered:

Without Lube

- a. Linear configuration with 1 adjacent conductors/contacts powered

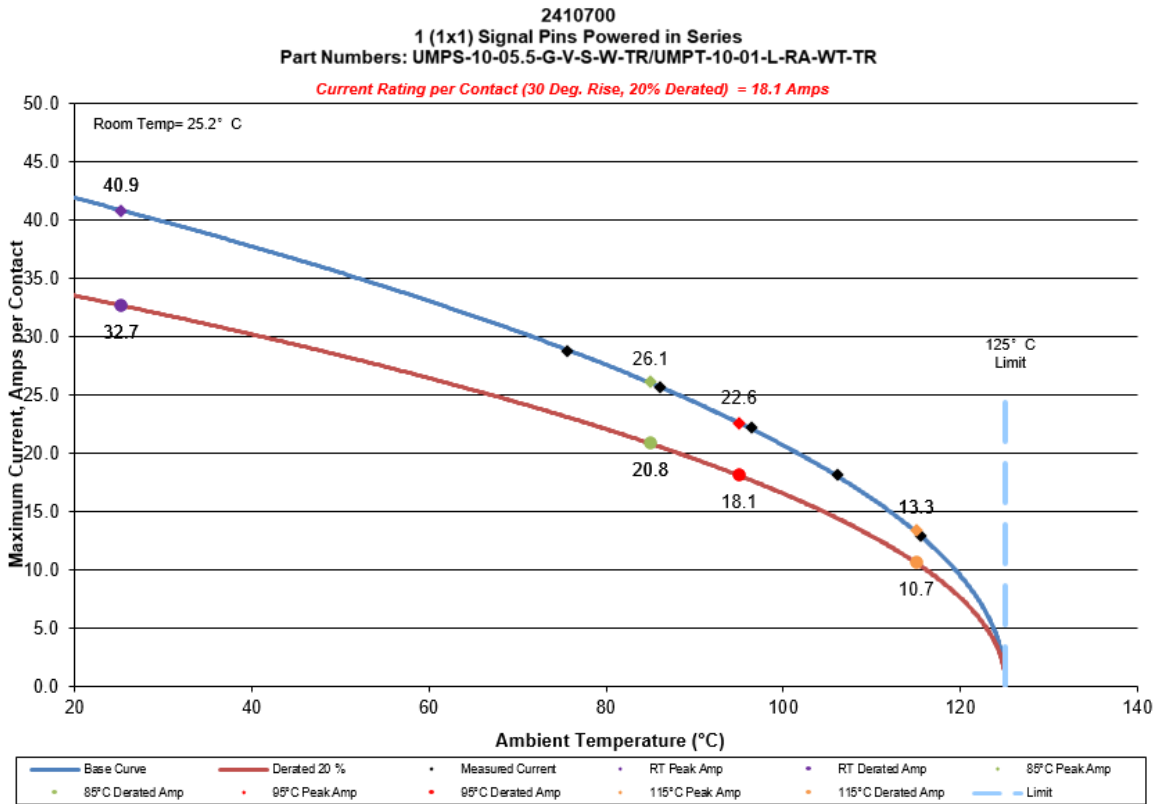

### DATA SUMMARIES

2410700  
1 (1x1) Signal Pins Powered in Series  
Part Numbers: UMPS-10-05.5-G-V-S-W-TR/UMPT-10-01-L-RA-WT-TR

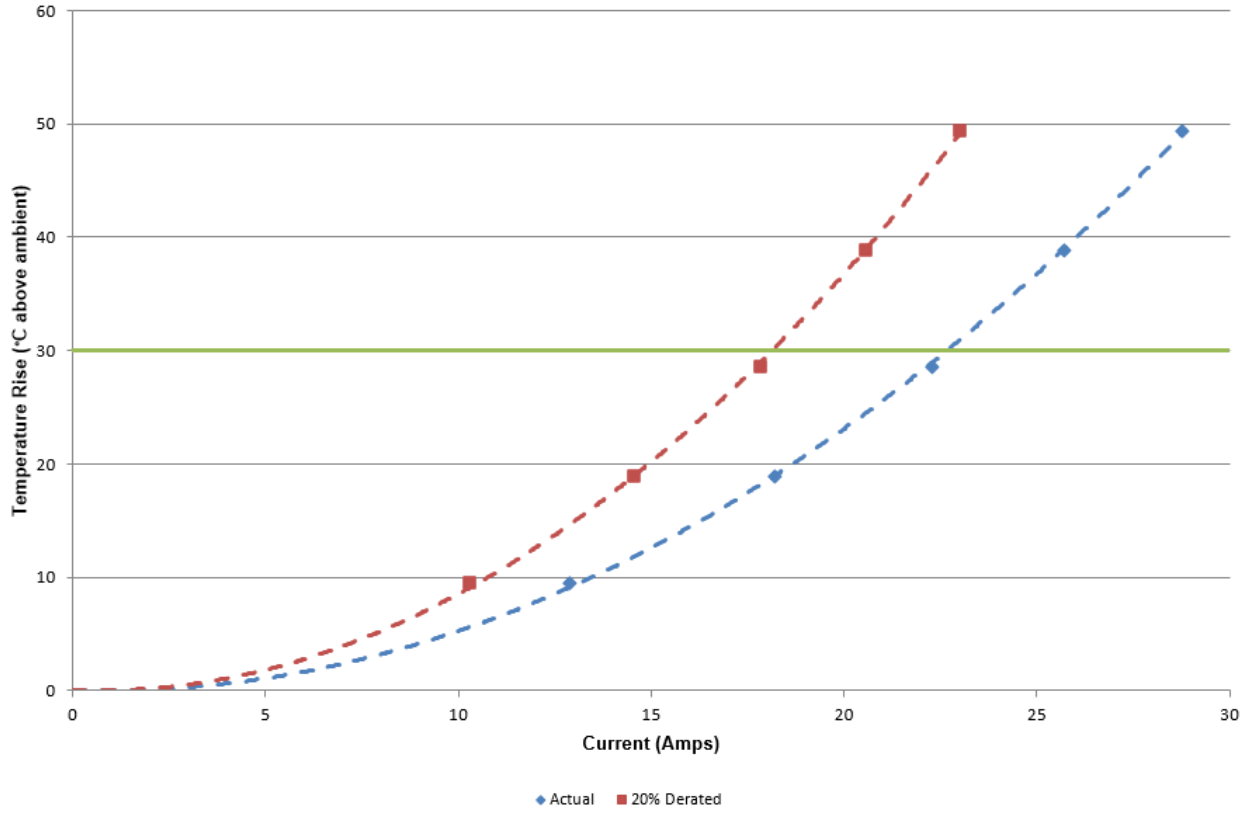

### DATA SUMMARIES Continued

b. Linear configuration with 2 adjacent conductors/contacts powered

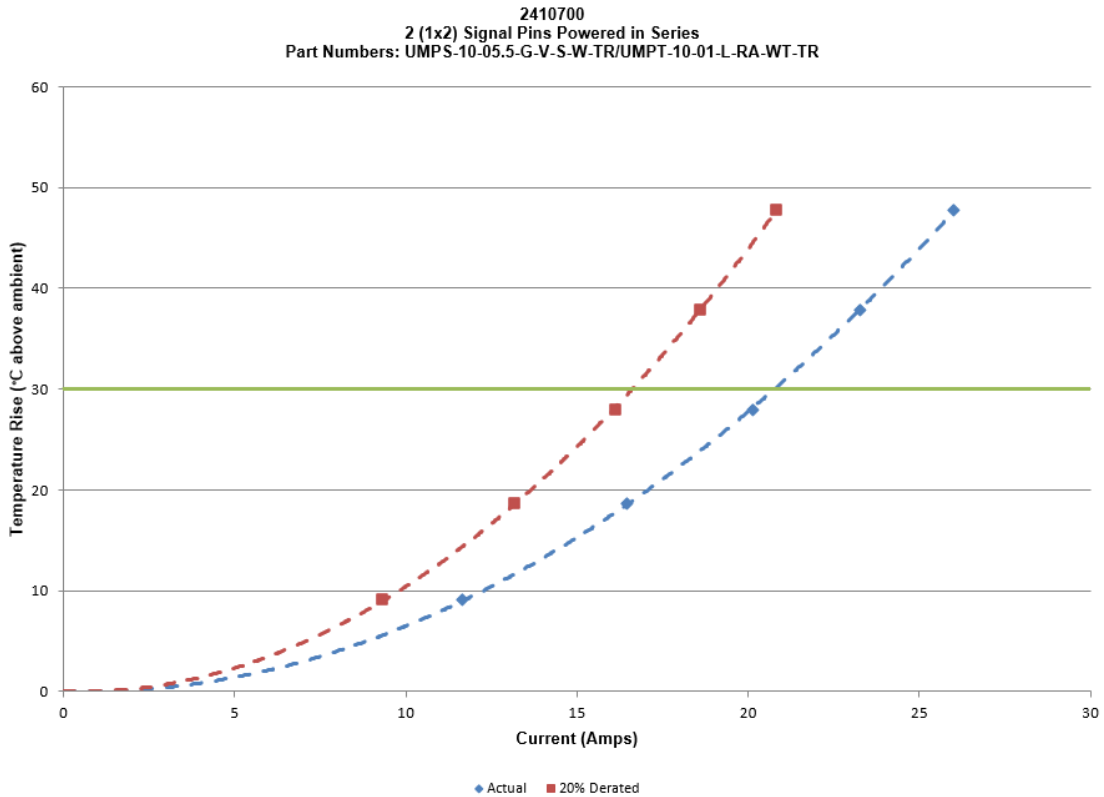
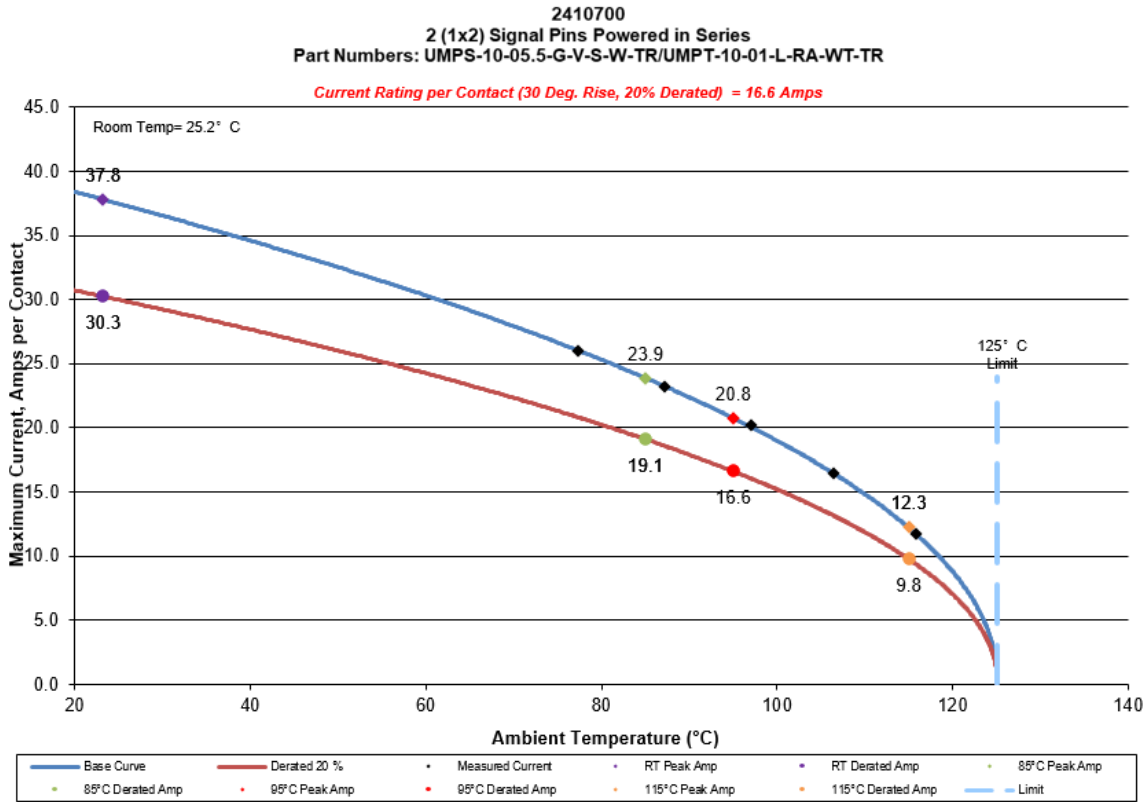

### DATA SUMMARIES Continued

c. Linear configuration with 3 adjacent conductors/contacts powered

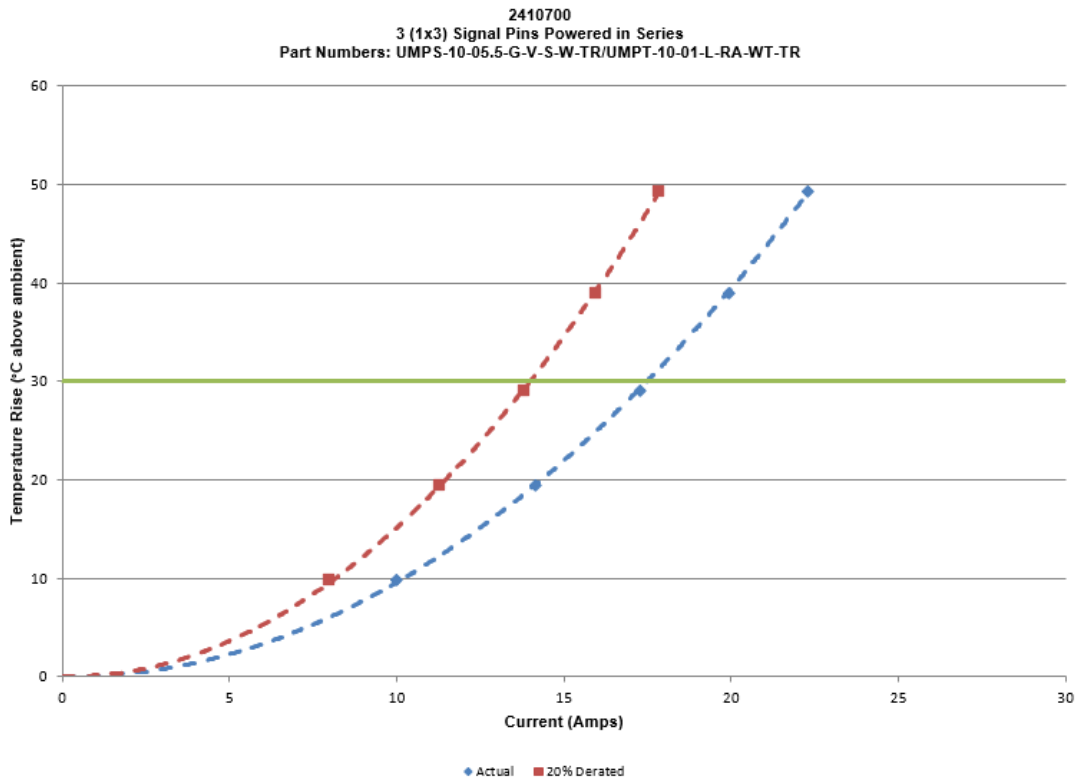
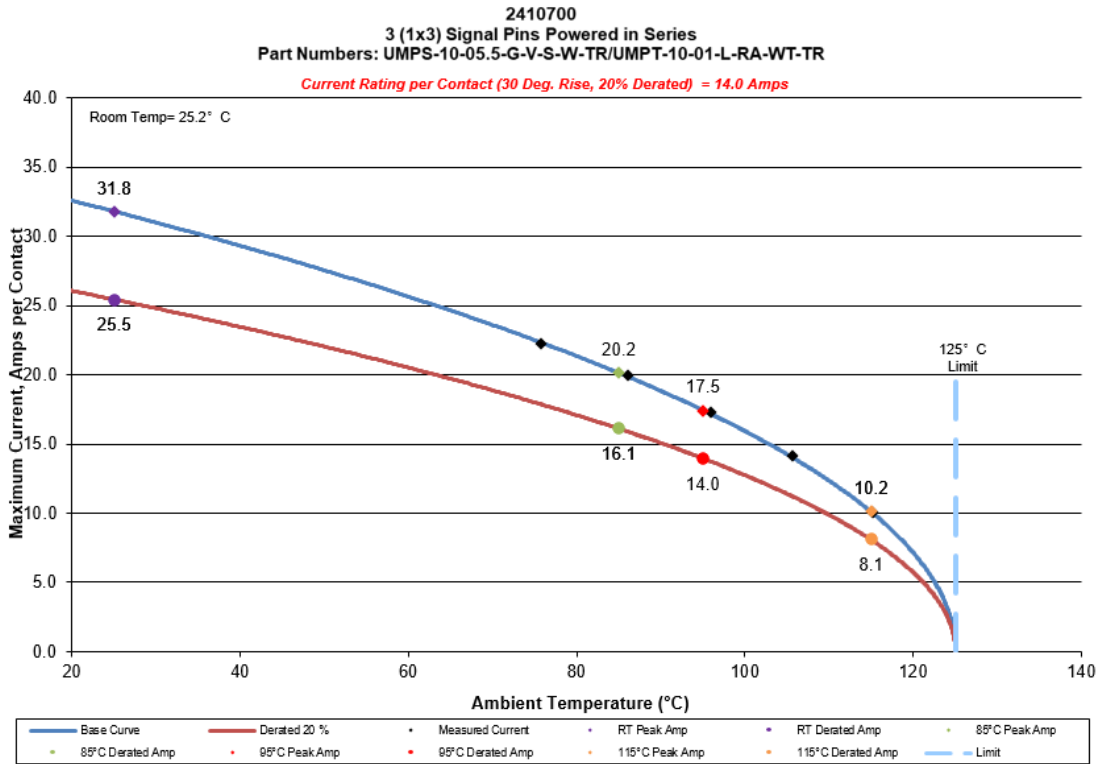

### DATA SUMMARIES Continued

d. Linear configuration with 4 adjacent conductors/contacts powered

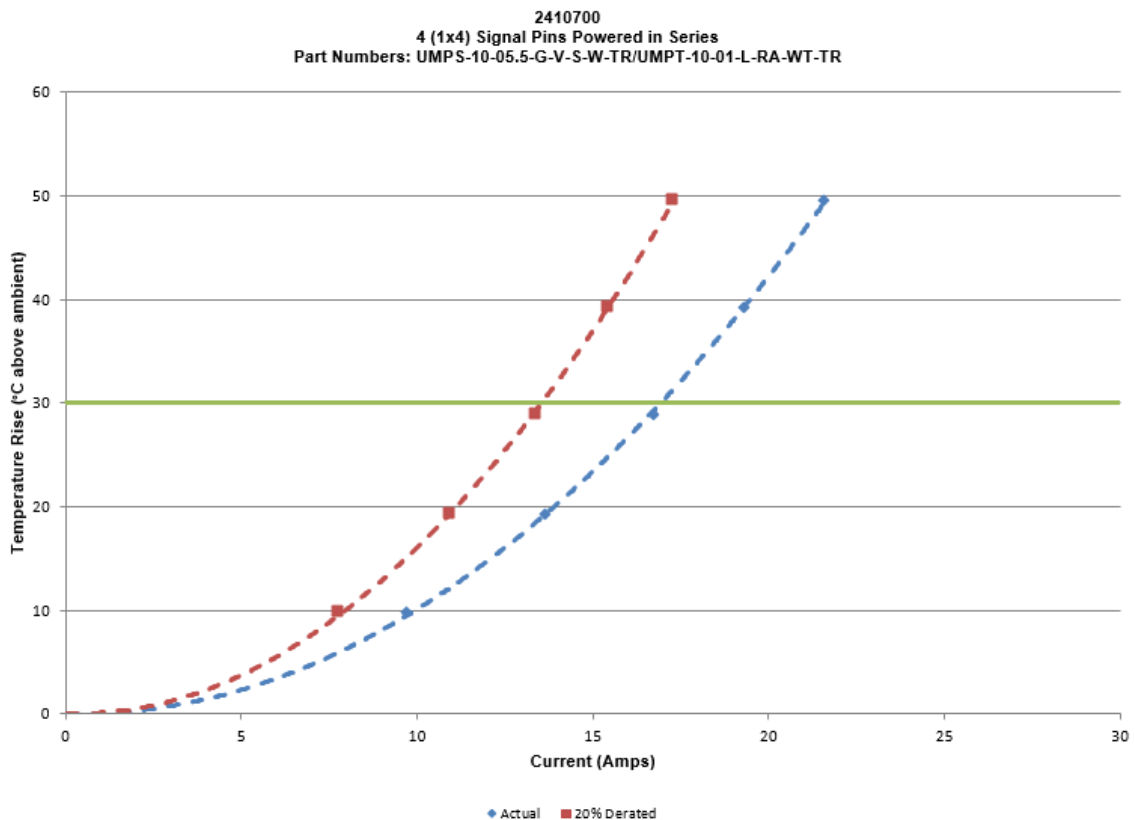
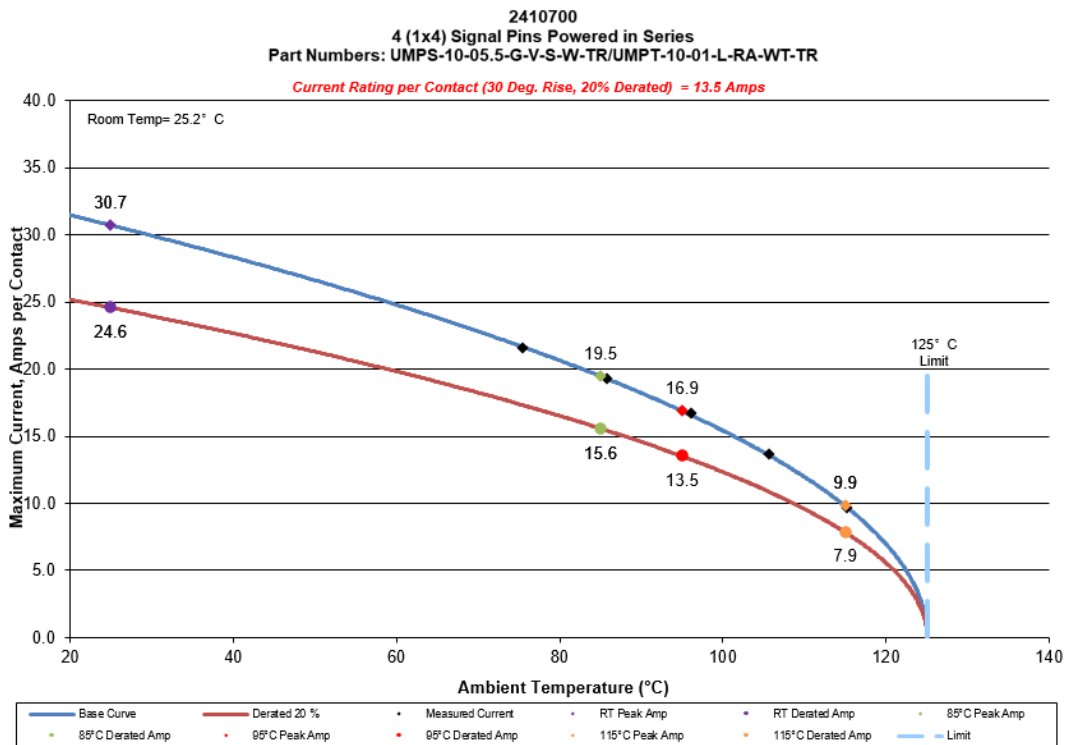

**DATA SUMMARIES Continued**

e. Linear configuration with all adjacent conductors/contacts powered

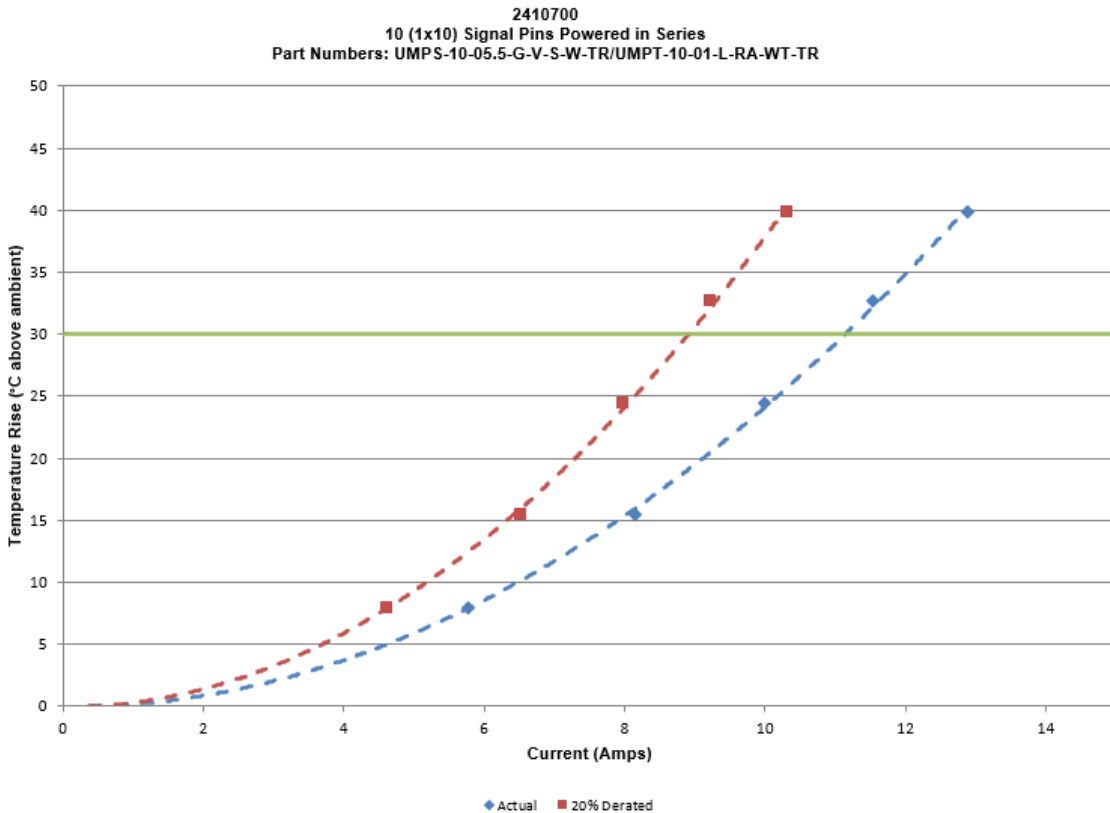
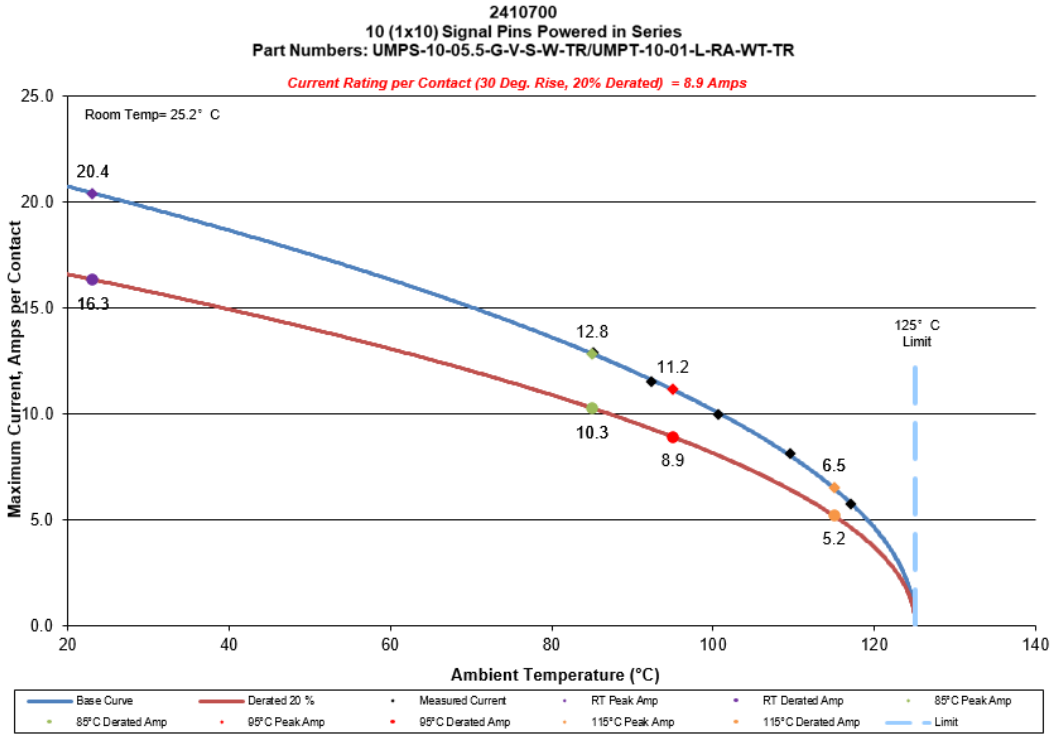



**DATA SUMMARIES Continued**

**Mating-Unmating basic (UMPS-10-05.5-G-V-S-W-TR/ UMPT-10-01-L-RA-WT-TR)**

	Initial				After 25 Cycles			
	Mating		Unmating		Mating		Unmating	
	Newton's	Force (Lbs)	Newton's	Force (Lbs)	Newton's	Force (Lbs)	Newton's	Force (Lbs)
Minimum	41.10	9.24	25.49	5.73	38.12	8.57	27.84	6.26
Maximum	48.66	10.94	27.31	6.14	44.08	9.91	30.20	6.79
<b>Average</b>	44.89	<b>10.09</b>	26.19	<b>5.89</b>	41.51	<b>9.33</b>	29.16	<b>6.56</b>
St Dev	2.29	0.51	0.59	0.13	2.09	0.47	0.73	0.16
Count	8	8	8	8	8	8	8	8
	After 50 Cycles				After 75 Cycles			
	Mating		Unmating		Mating		Unmating	
	Newton's	Force (Lbs)	Newton's	Force (Lbs)	Newton's	Force (Lbs)	Newton's	Force (Lbs)
Minimum	32.74	7.36	28.73	6.46	16.55	3.72	29.18	6.56
Maximum	36.96	8.31	31.71	7.13	33.40	7.51	31.80	7.15
<b>Average</b>	33.87	<b>7.61</b>	30.22	<b>6.80</b>	30.54	<b>6.87</b>	30.41	<b>6.84</b>
St Dev	1.40	0.32	1.04	0.23	5.68	1.28	0.92	0.21
Count	8	8	8	8	8	8	8	8
	After 100 Cycles							
	Mating		Unmating					
	Newton's	Force (Lbs)	Newton's	Force (Lbs)				
Minimum	31.58	7.10	29.94	6.73				
Maximum	34.12	7.67	32.16	7.23				
<b>Average</b>	32.91	<b>7.40</b>	30.60	<b>6.88</b>				
St Dev	0.72	0.16	0.81	0.18				
Count	8	8	8	8				

**DATA SUMMARIES Continued****Mating-Unmating Basic** (UMPS-02-05.5-G-V-S-W-TR/ UMPT-02-01-L-RA-WT-TR)

	Initial				After 25 Cycles			
	Mating		Unmating		Mating		Unmating	
	Newton's	Force (Lbs)	Newton's	Force (Lbs)	Newton's	Force (Lbs)	Newton's	Force (Lbs)
Minimum	8.10	1.82	5.56	1.25	8.98	2.02	6.54	1.47
Maximum	10.72	2.41	7.25	1.63	10.72	2.41	7.96	1.79
<b>Average</b>	9.36	<b>2.11</b>	6.52	<b>1.47</b>	9.95	<b>2.24</b>	7.26	<b>1.63</b>
St Dev	0.80	0.18	0.58	0.13	0.55	0.12	0.52	0.12
Count	8	8	8	8	8	8	8	8
	After 50 Cycles				After 75 Cycles			
	Mating		Unmating		Mating		Unmating	
	Newton's	Force (Lbs)	Newton's	Force (Lbs)	Newton's	Force (Lbs)	Newton's	Force (Lbs)
Minimum	7.74	1.74	7.25	1.63	7.78	1.75	7.70	1.73
Maximum	10.01	2.25	8.90	2.00	9.70	2.18	9.34	2.10
<b>Average</b>	8.68	<b>1.95</b>	8.30	<b>1.87</b>	8.82	<b>1.98</b>	8.73	<b>1.96</b>
St Dev	0.70	0.16	0.65	0.15	0.68	0.15	0.55	0.12
Count	8	8	8	8	8	8	8	8
	After 100 Cycles							
	Mating		Unmating					
	Newton's	Force (Lbs)	Newton's	Force (Lbs)				
Minimum	8.18	1.84	7.92	1.78				
Maximum	10.01	2.25	9.47	2.13				
<b>Average</b>	8.96	<b>2.02</b>	8.89	<b>2.00</b>				
St Dev	0.62	0.14	0.61	0.14				
Count	8	8	8	8				

**DATA SUMMARIES Continued**

**LLCR Mating/Unmating Durability Group**

- 1). A total of 40 points were measured.
- 2). EIA-364-23, *Low Level Contact Resistance Test Procedure for Electrical Connectors and Sockets*.
- 3). A computer program, *LLCR 221.exe*, ensures repeatability for data acquisition.
- 4). The following guidelines are used to categorize the changes in LLCR as a result from stressing.
  - a.  $\leq +0.33$  mOhms: -----Stable
  - b.  $+0.34$  to  $+0.66$  mOhms: -----Minor
  - c.  $+0.67$  to  $+1.00$  mOhms: -----Acceptable
  - d.  $+1.01$  to  $+50.0$  mOhms: -----Marginal
  - e.  $+50.1$  to  $+1000$  mOhms: -----Unstable
  - f.  $>+1000$  mOhms:-----Open Failure

<b>LLCR Measurement Summaries by Pin Type</b>				
Date	5/26/2020	5/29/2020	6/4/2020	6/15/2020
Room Temp (Deg C)	23	23	23	23
Rel Humidity (%)	51	54	54	54
Technician	Peter Chen	Peter Chen	Peter Chen	Peter Chen
mOhm values	<b>Actual</b>	<b>Delta</b>	<b>Delta</b>	<b>Delta</b>
	<b>Initial</b>	<b>100 Cycles</b>	<b>Therm Shck</b>	<b>Humidity</b>
<b>Pin Type 1: Signal</b>				
Average	1.09	0.03	0.03	0.09
St. Dev.	0.06	0.02	0.02	0.08
Min	1.00	0.00	0.00	0.00
Max	1.24	0.11	0.08	0.31
Summary Count	32	32	32	32
Total Count	32	32	32	32

<b>LLCR Delta Count by Category</b>						
mOhms	Stable	Minor	Acceptable	Marginal	Unstable	Open
	$\leq 5$	$>5 \ \& \ \leq 10$	$>10 \ \& \ \leq 15$	$>15 \ \& \ \leq 50$	$>50 \ \& \ \leq 1000$	$>1000$
<b>100 Cycles</b>	<b>32</b>	<b>0</b>	<b>0</b>	<b>0</b>	<b>0</b>	<b>0</b>
<b>Therm Shck</b>	<b>32</b>	<b>0</b>	<b>0</b>	<b>0</b>	<b>0</b>	<b>0</b>
<b>Humidity</b>	<b>32</b>	<b>0</b>	<b>0</b>	<b>0</b>	<b>0</b>	<b>0</b>

**EQUIPMENT AND CALIBRATION SCHEDULES****Equipment #:** HZ-MO-03**Description:** Micro-ohmmeter**Manufacturer:** Keithley**Model:** 580**Serial #:** 297288**Accuracy:** Last Cal: 2019-8-06, Next Cal: 2020-8-05**Equipment #:** HZ-TCT-01**Description:** Normal force analyzer**Manufacturer:** Mecmesin Multitester**Model:** Mecmesin Multitester 2.5-i**Serial #:** 08-1049-04**Accuracy:** Last Cal: 2019-4-28, Next Cal: 2020-4-27**Equipment #:** HZ-THC-01**Description:** Humidity transmitter**Manufacturer:** Thermtron**Model:** HMM30C**Serial #:** D0240037**Accuracy:** Last Cal: 2019-3-3, Next Cal: 2020-3-2**Equipment #:** HZ-MO-01**Description:** Micro-ohmmeter**Manufacturer:** Keithley**Model:** 2700**Serial #:** 1199807**Accuracy:** Last Cal: 2019-4-28, Next Cal: 2020-4-27**Equipment #:** HZ-PS-01**Description:** Power Supply**Manufacturer:** Agilent**Model:** 6031A**Serial #:** MY41000982**Accuracy:** Last Cal: 2019-4-28, Next Cal: 2020-4-27**Equipment #:** HZ-TSC-01**Description:** Thermal Shock transmitter**Manufacturer:** Keithley**Model:** 10-VT14994**Serial #:** VTS-3-6-6-SC/AC**Accuracy:** Last Cal: 2019-11-1, Next Cal: 2020-11-1