

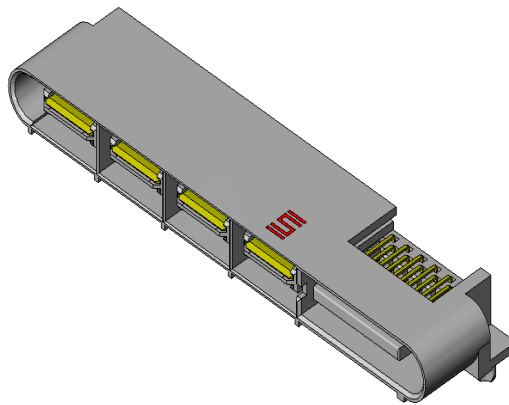

Project Number: 252369	Tracking Code: 252369_Power Test Report_Rev_1 .doc
Requested by: Leo Lee	Date: 06/08/2013
Part #: LPHS-08-32-L-VP1-GP/ LPHT-08-32-L-RT1-GP	
Part description: LPHS/LPHT	Technician: Tony Wagoner
Test Start: 05/15/2013	Test Completed: 06/05/2013

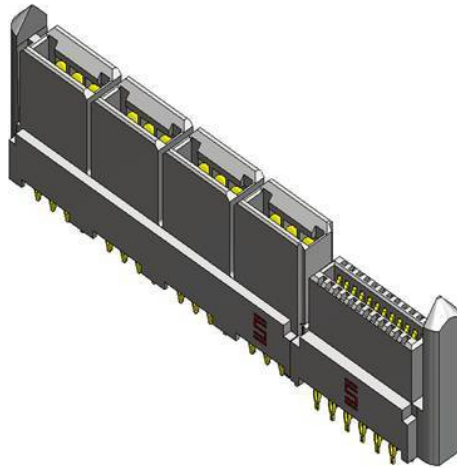

SAMTEC POWER CHARACTERIZATION

PART DESCRIPTION

LPHS-08-32-L-VP1-GP/ LPHT-08-32-L-RT1-GP

CERTIFICATION

All instruments and measuring equipment were calibrated to National Institute for Standards and Technology (NIST) traceable standards according to ISO 10012-1 and ANSI/NCSL 2540-1, as applicable.

All contents contained herein are the property of Samtec. No portion of this report, in part or in full shall be reproduced without prior written approval of Samtec.

SCOPE

1. Temperature Rise/Current Carrying Capacity
 - 1.1. To determine the amount of current the device under test (DUT) can safely carry over the operating temperature range of the DUT.
 - 1.2. Contact loading will also be addressed in this document which will determine how much current can be carried as the number of energized contacts is varied.
2. Current Cycling
 - 2.1. To determine the performance of the device under test (DUT) when subjected to the power-on/power-off cycling that heats and cools the DUT in normal everyday use.
 - 2.2. Contact loading will set to 100% throughout the test.

APPLICABLE DOCUMENTS

Standards: EIA Publication 364-70 Temperature Rise
EIA Publication 364-06 Contact Resistance
EIA Publication 364-55 Current Cycling
TLPM-032 Current Carrying Capacity
TLPM-084 Current Cycling
IEC 512-3 Electromechanical Components for Electronic Equipment: Basic Testing Procedures and Measuring Methods, Part 3: Current Carrying Capacity Tests

TEST SAMPLES AND PREPARATION

- 1) All materials shall be manufactured in accordance with the applicable product specification.
- 2) All test samples shall be identified and encoded to maintain traceability throughout the test sequences.
- 3) After soldering, the parts to be used shall be cleaned according to TLWI-0001.
- 4) All samples shall be visually inspected and cleaned as necessary.
- 5) Any additional preparation shall be noted in the individual test sequences.
- 6) Solder Information: Lead Free
- 7) Re-Flow Time/Temp: See accompanying profile.
- 8) All products designed to operate mounted on a printed circuits board shall be tested mounted to test boards in accordance with EIA-364-70.

PREPARED TEST SAMPLE

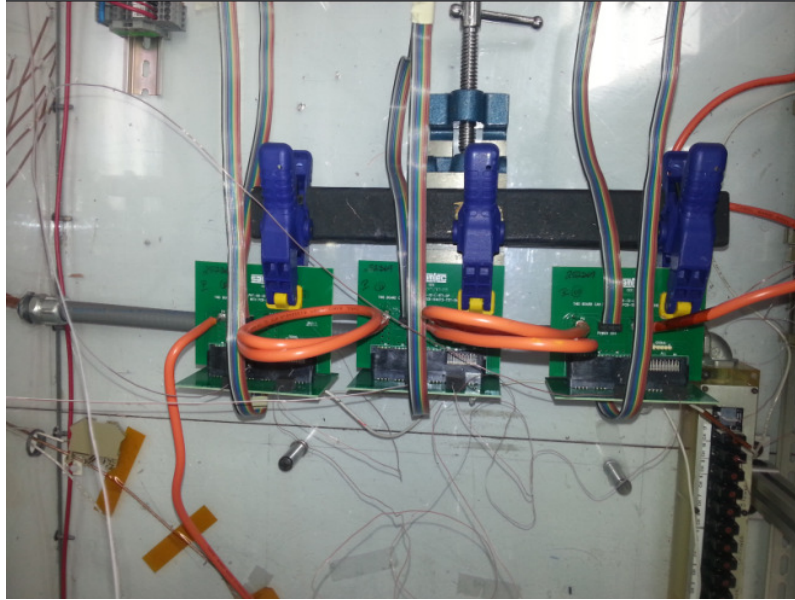

- 9) The following loading configurations shall be tested for Temperature Rise/Current Carrying Capacity testing of two row connector systems:
- a. Two by One contact energized
 - b. Two by Two contacts energized adjacent to each other
 - c. Two by Three contacts energized adjacent to each other
 - d. Two by Four contacts energized adjacent to each other
 - e. All contacts energized

Test Condition as in 10.1 above

✦ Indicates energized contacts

✦ Indicates thermocouple monitored, energized contacts
✦ Indicates thermocouple monitored, energized contacts

10) For Current Cycling, only 100 % loading will be tested.

✦			
✦			

OVEN PROFILE (Soldering Parts to Test Boards)

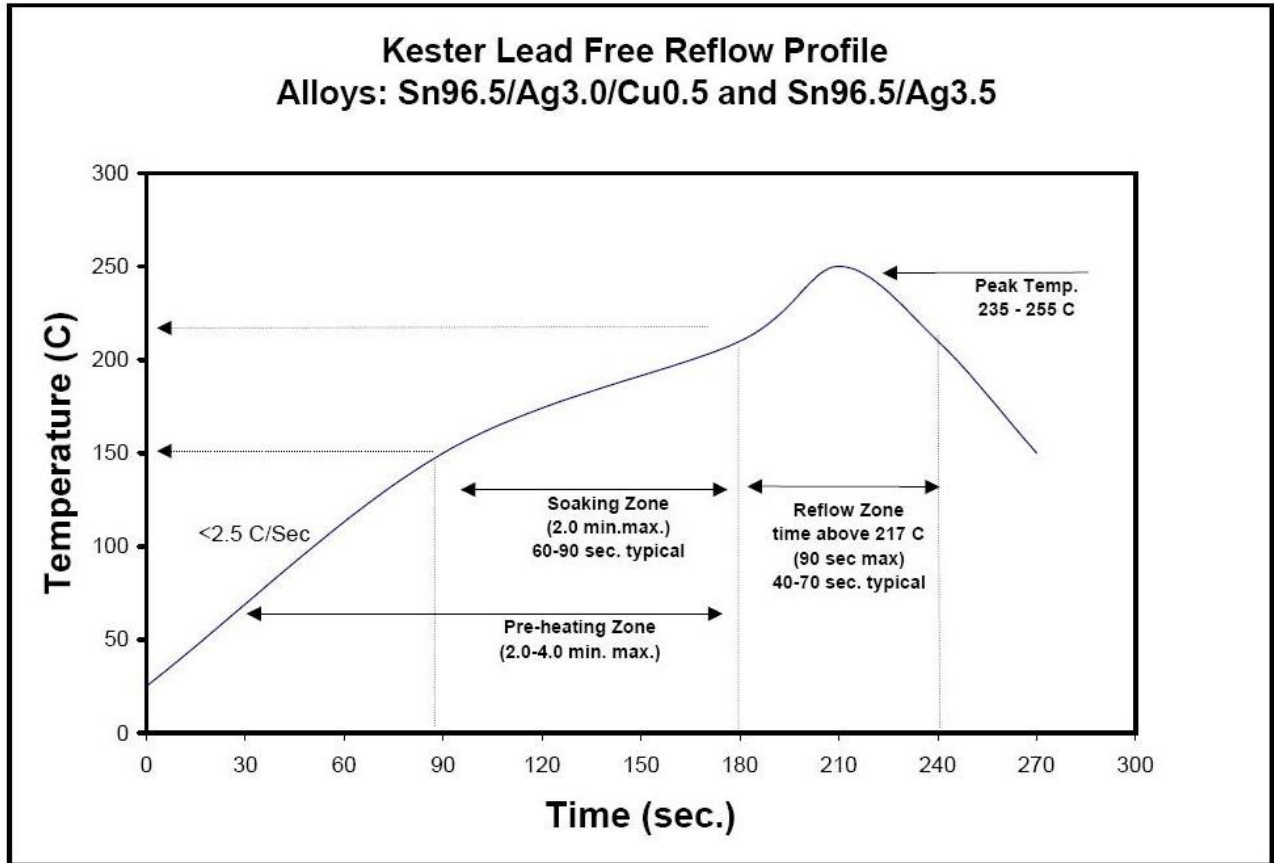



POWER INTEGRITY TEST REPORT

252369

INITIAL RELEASE

FLOWCHARTS

POWER PINS

Current Carrying Capacity - Power Pins

TEST STEP	GROUP A1 3 Mated Assemblies 2 Contact Powered .0335"/.0422" ENIG PTH	GROUP A2 3 Mated Assemblies 4 Contacts Powered .0335"/.0422" ENIG PTH	GROUP A3 3 Mated Assemblies 6 Contacts Powered .0335"/.0422" ENIG PTH	GROUP A4 3 Mated Assemblies All Contacts Powered .0335"/.0422" ENIG PTH
01	CCC	CCC	CCC	CCC

SIGNAL PINS

Current Carrying Capacity - Signal Pins

TEST STEP	GROUP D1 3 Mated Assemblies 2 Pins Powered .0335"/.0422" ENIG PTH	GROUP D2 3 Mated Assemblies 4 Pins Powered .0335"/.0422" ENIG PTH	GROUP D3 3 Mated Assemblies 6 Pins Powered .0335"/.0422" ENIG PTH	GROUP D4 3 Mated Assemblies 8 Pins Powered .0335"/.0422" ENIG PTH	GROUP D5 3 Mated Assemblies All Contacts Powered .0335"/.0422" ENIG PTH
01	CCC	CCC	CCC	CCC	CCC

POWER & SIGNAL PINS

Current Carrying Capacity - Power and Signal Pins

TEST STEP	GROUP E1 3 Mated Assemblies Signal Pins @ 1/2 rated current from Group D5 Power Pins - All Contacts Powered .0335"/.0422" ENIG PTH
01	CCC

(TIN PLATING) - Tabulate calculated current at RT, 65°C, 75°C and 95°C after derating 20% and based on 105°C

(GOLD PLATING) - Tabulate calculated current at RT, 85°C, 95°C and 115°C after derating 20% and based on 125°C

CCC, Temp rise = EIA-364-70

Current Cycling

TEST STEP	GROUP A1 8 Mated Assemblies (Power Pins Only) .0335"/.0422" ENIG PTH
01	Current Cycle, 500 cycles

Current Cycle = EIA 364-55, Condition "B", Method #4

Test at Current Listed

Each cycle is 60 minutes

ON time is 45 minutes

OFF time is 15 minutes

Measure at 40 minutes into 45 minute ON time

ON current is 125% of the rated current



POWER INTEGRITY TEST REPORT

252369

INITIAL RELEASE

TEST PROCEDURES

Part No.	LPHS-08-32-L-VP1-GP	Mating Part No.	LPHT-08-32-L-RT1-GP
Sample Size	15	Technician	Tony Wagoner
Start Date	05/15/2013	Complete Date	06/05/2013
Room Ambient	23°C	Relative Humidity	49%
Equipment ID#: MO-04, PS-11, TCS-029, TCS-037, TCS-042, 252369-(001 - 030)			

TEMPERATURE RISE (Current Carrying Capacity, CCC):

- 1) Thermocouples shall be calibrated in accordance with Samtec documents; TLWI 0003, Thermocouple Welding Procedure and TLWI 0005, Thermocouple Calibration
- 2) The thermocouples shall be placed at a location to sense the maximum temperature generated during testing.
- 3) Temperature stability shall be defined as the temperature at which three successive readings, 5 minutes apart, differ not more than 1° C (computer controlled data acquisition). This is the Temperature Rise that the Current Carrying Capacity and De-rating curves are based on.
- 4) The following loading configurations shall be tested (double for two row systems):
 - a. One contact energized only
 - b. Two contacts energized adjacent to each other
 - c. Three contacts energized adjacent to each other
 - d. Four contacts energized adjacent to each other
 - e. All contacts energized
- 5) The following loading configurations shall be tested for Temperature Rise/Current Carrying Capacity testing of two row connector systems:
 - a. Two by One contact energized
 - b. Two by Two contacts energized adjacent to each other
 - c. Two by Three contacts energized adjacent to each other
 - d. Two by Four contacts energized adjacent to each other
 - e. All contacts energized
- 6) Three samples shall be tested for each of the above configurations for a total of eighteen assemblies.
- 7) Temperature Rise measurements shall be made at 5 different current levels yielding temperature rises in the 10 to 70°C range.
- 8) The base curve for the Current Rating chart will be derived from the average (maximum) value of three test specimens in accordance with IEC 512-3, Test 5b.



**POWER INTEGRITY TEST
REPORT**

252369

INITIAL RELEASE

Part No.	LPHS-08-32-L-VP1-GP	Mating Part No.	LPHT-08-32-L-RT1-GP
Sample Size	15	Technician	Tony Wagoner
Start Date	05/15/2013	Complete Date	06/05/2013
Room Ambient	23°C	Relative Humidity	49%
Equipment ID#: MO-09;TCS-031;TCS-047;TCS-001;TCS-039;TCS-037;TCS-028;TCS-006;TCS-012;TCS-050;TCS-012;THL-11;RS-01, 252369(047 - 054)			

CURRENT CYCLING

1. Samples shall be prepared and tested as above (paragraph 14.5).
2. Current Cycling shall be performed in accordance with EIA-364-55, Test Condition
3. Testing shall be as follows:
 - 3.1. Test Current: **TEST CURRENT**(125% of 30°C Rating)
 - 3.2. "ON" Time: 45 Minutes
 - 3.3. "OFF" Time: 15 Minutes
 - 3.4. Number of Cycles: 500
 - 3.5. Measurements: 40 minutes into ON cycle
 - 3.5.1. Temperature
 - 3.5.2. Voltage Drop/Contact Resistance
4. Temperature vs. Number of Cycles and Voltage Drop vs. Number of Cycles shall be measured and recorded.



TEST RESULTS

CURRENT CARRYING CAPACITY (CCC) RESULTS

- There was no evidence of physical damage to the test samples as tested.
- The following is a summary of the observed data:

Temperature Rise, CCC at a 20% de-rating

Power pin

- CCC for a 30°C Temperature Rise -----30.8 A per contact with 2 contacts (2 x 1) powered
- CCC for a 30°C Temperature Rise -----28.5 A per contact with 4 contacts (2 x 2) powered
- CCC for a 30°C Temperature Rise -----25.3 A per contact with 6 contacts (2 x 3) powered
- CCC for a 30°C Temperature Rise -----23.6 A per contact with 8 contacts (All) powered

Signal pin

- CCC for a 30°C Temperature Rise -----2.5 A per contact with 2 contacts (2 x 1) powered
- CCC for a 30°C Temperature Rise -----2.1 A per contact with 4 contacts (2 x 2) powered
- CCC for a 30°C Temperature Rise -----1.8 A per contact with 6 contacts (2 x 3) powered
- CCC for a 30°C Temperature Rise -----1.7 A per contact with 8 contacts (2 x 4) powered
- CCC for a 30°C Temperature Rise -----1.0 A per contact with 32 contacts (All) powered

Power pin and signal pin (signal contacts powered @ 1/2 rated current @ 0.65 AMPS.)

- CCC for a 30°C Temperature Rise-----23.1 A per contact with all adjacent power contacts powered

CURRENT CYCLING RESULTS

Test Condition: 500 Cycles, 45 minutes ON and 15 minutes OFF

- Test Current -----28.9 Amps
- Contact Resistances, Measured 40 minutes into the FIRST and LAST ON cycle
 - Initial
 - Min ----- 0.20mOhms
 - Max----- 0.44mOhms
 - Final
 - Min ----- 0.19mOhms
 - Max----- 0.40mOhms
- Temperature Change, Measured 40 minutes into the FIRST and LAST ON cycle
 - Initial Temperature Change -----29.6°C
 - Final Temperature Change -----27.4°C

TEST DATA

CONTACT RESISTANCE @ RATED CURRENT - DC Resistance (DCR)

The following data represents the Voltage drop and Contact Resistance at Rated Current for the 100% energized samples:

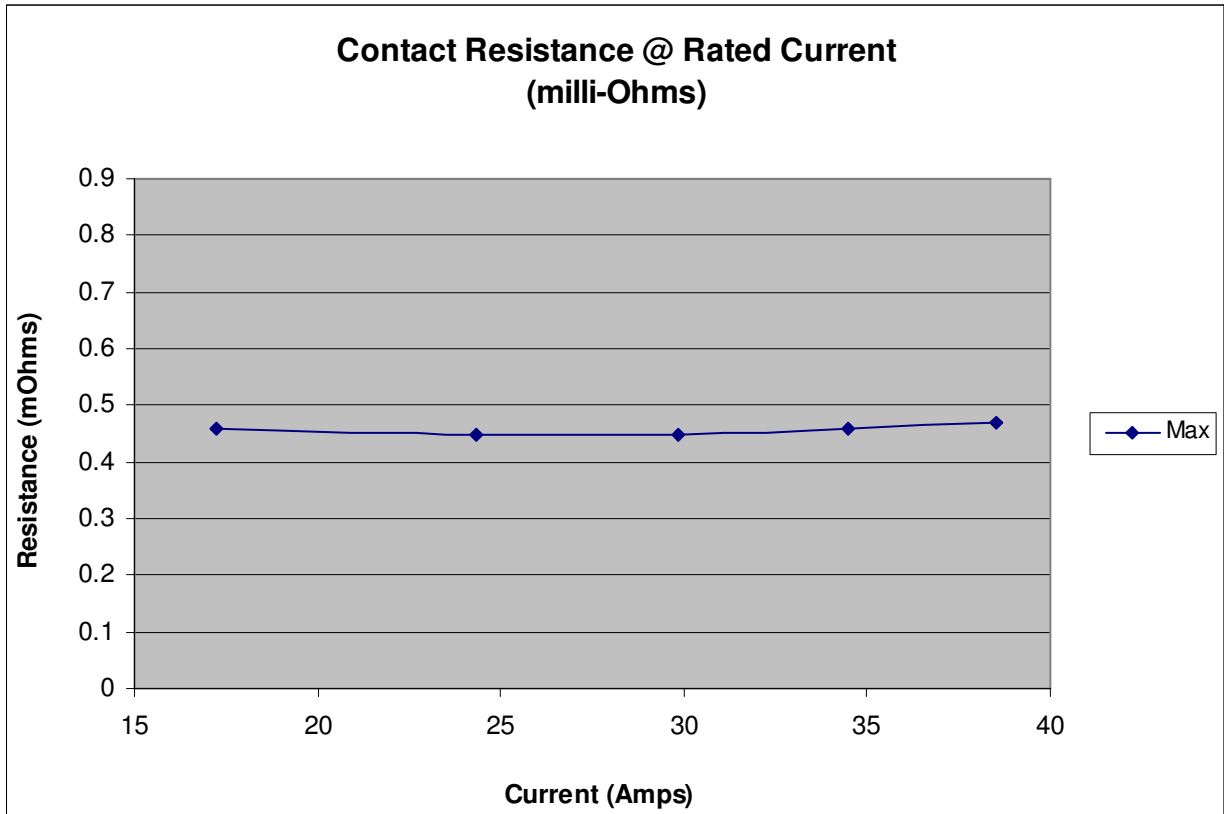

**CONTACT RESISTANCE DATA
ALL CONTACTS ENERGIZED
(mΩ)**

TEST CURRENT AMPS	17.23	24.35	29.84	34.47	38.55
Min	0.19	0.20	0.2	0.2	0.2
Max	0.46	0.45	0.45	0.46	0.47
Avg	0.27	0.27	0.27	0.28	0.28

TEST DATA

VOLTAGE DROP @ RATED CURRENT

The following data represents the Voltage drop at Rated Current for the 100% energized samples:

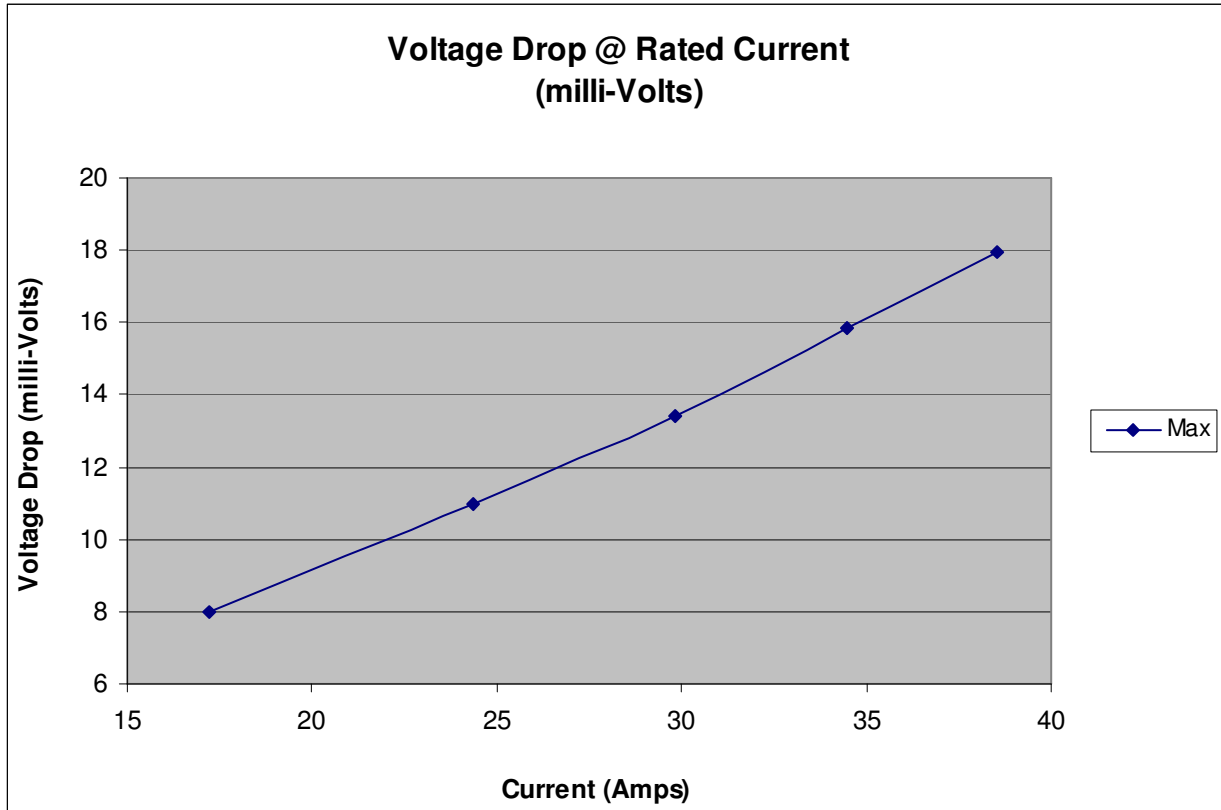

**VOLTAGE DROP DATA
ALL CONTACTS ENERGIZED
(mV)**

TEST CURRENT AMPS	17.23	24.34	29.84	34.47	38.55
Min	3.33	4.8	5.92	7.2	7.88
Max	8.01	10.96	13.44	15.85	17.95
Avg	4.5	6.39	7.93	9.36	10.62

CURRENT CARRYING CAPACITY DATA

252369
2 (2x1) Power Pins Powered in Series
Part Numbers: LPHS-08-32-L-VP1-GP / LPHT-08-32-L-RT1-GP

Current Rating per Contact (30 Deg. Rise, 20% Derated) = 30.8 Amps

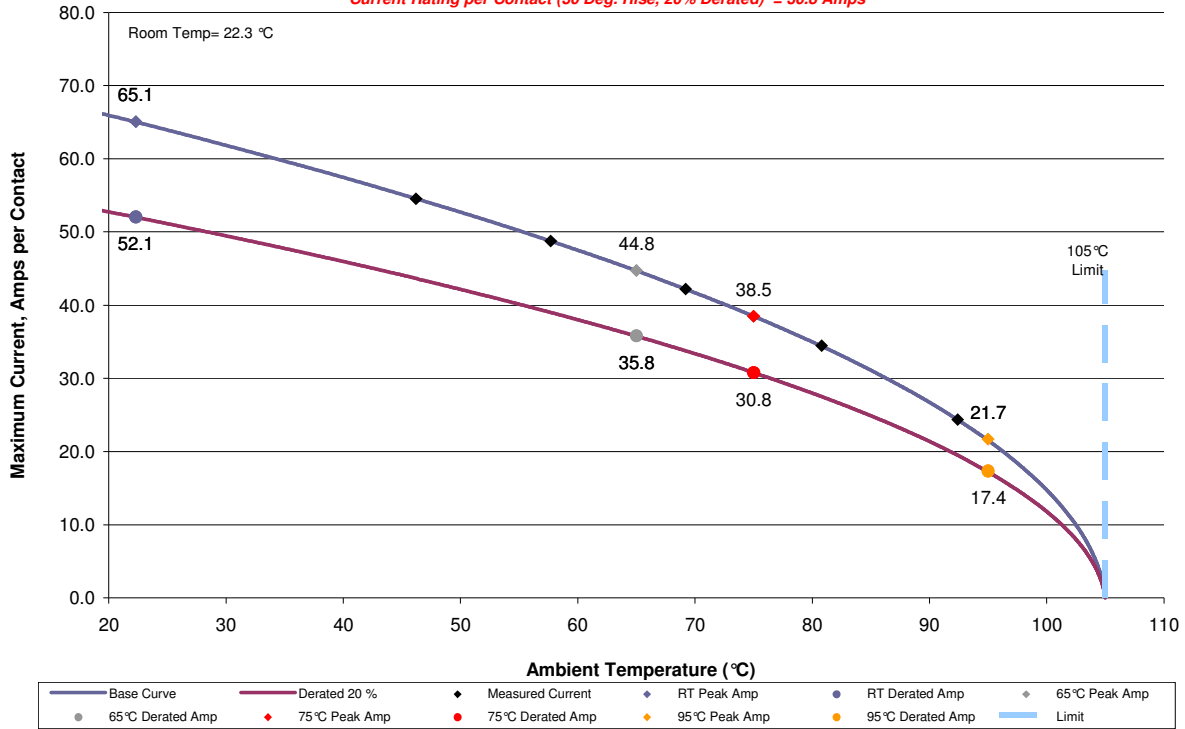

252369
2 (2x1) Power Pins Powered in Series
Part Numbers: LPHS-08-32-L-VP1-GP / LPHT-08-32-L-RT1-GP

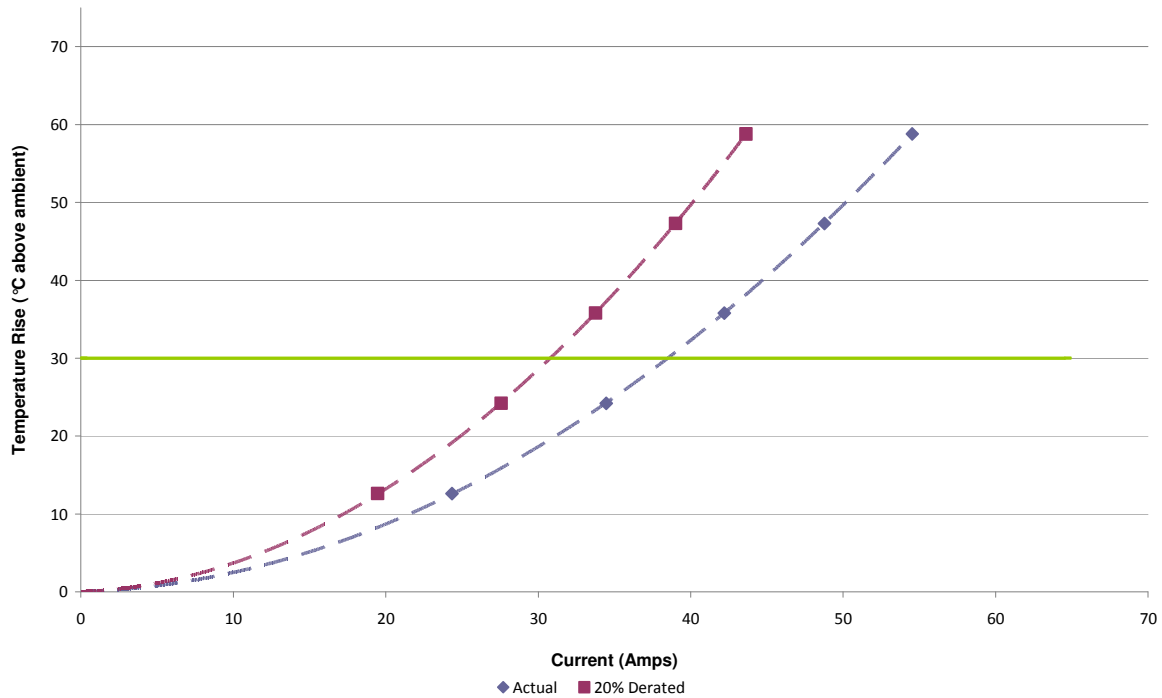



POWER INTEGRITY TEST REPORT

252369

INITIAL RELEASE

TEMPERATURE RISE DATA TWO CONTACT ENERGIZED (Degrees Celsius above ambient)

TEST CURRENT AMPS	24.34	34.46	42.21	48.76	54.53
Sample 1	12.6	24.1	35.7	47.2	59.5
Sample 2	12.0	23.2	34.6	46.1	56.8
Sample 3	13.2	25.4	37.0	48.5	60.2
Min	12.0	23.2	34.6	46.1	56.8
Max	13.2	25.4	37	48.5	60.2
Avg	12.6	24.23	35.77	47.27	58.83

Double Row Configuration

✦ Indicates energized contacts

✦ Indicates thermocouple monitoring

✦			
✦			

252369
4 (2x2) Power Pins Powered in Series
Part Numbers: LPHS-08-32-L-VP1-GP / LPHT-08-32-L-RT1-GP

Current Rating per Contact (30 Deg. Rise, 20% Derated) = 28.5 Amps

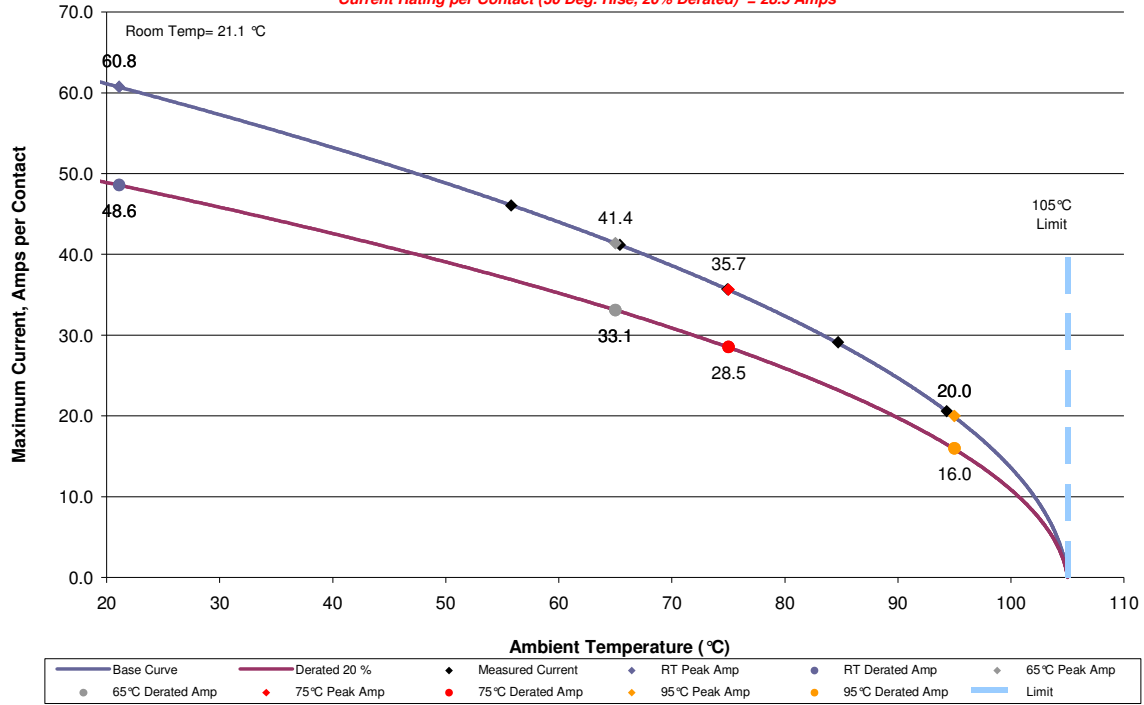

252369
4 (2x2) Power Pins Powered in Series
Part Numbers: LPHS-08-32-L-VP1-GP / LPHT-08-32-L-RT1-GP

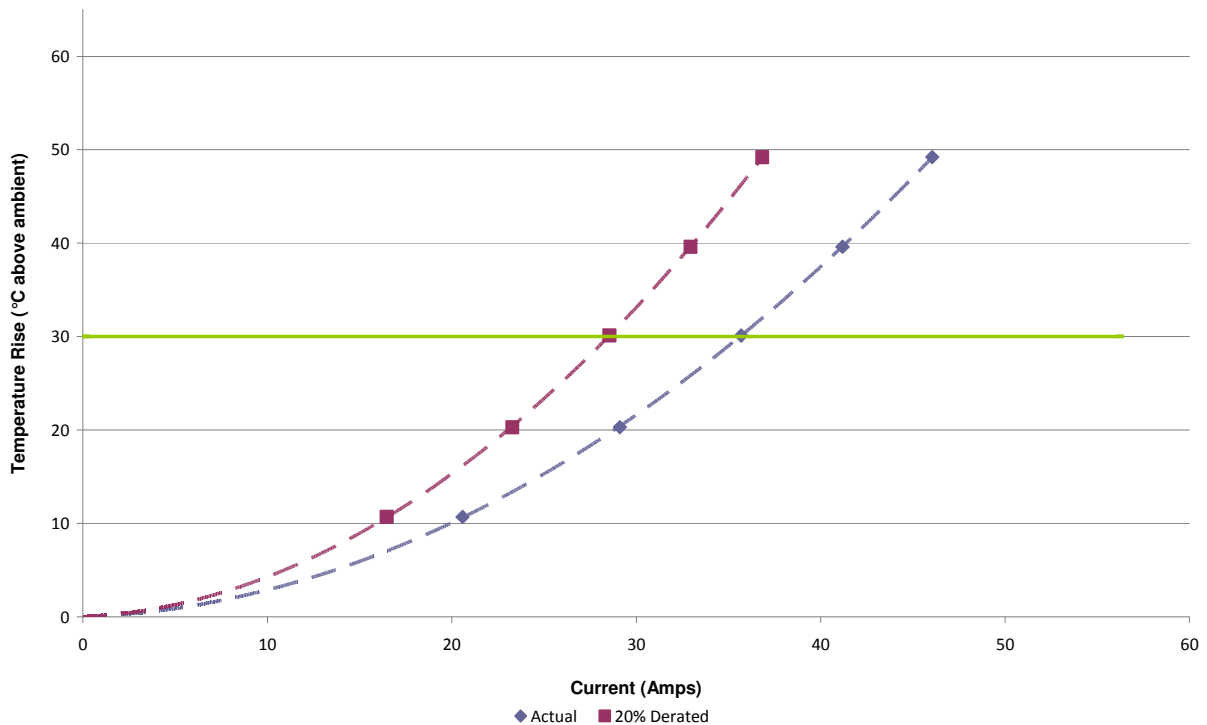



POWER INTEGRITY TEST REPORT

252369

INITIAL RELEASE

TEMPERATURE RISE DATA FOUR CONTACTS ENERGIZED (Degrees Celsius above ambient)

TEST CURRENT AMPS	20.59	29.11	35.68	41.19	46.05
Sample 4	10.6	20.3	29.9	39.0	48.6
Sample 5	10.5	19.9	29.8	39.1	49.1
Sample 6	10.9	20.8	30.7	40.6	50.0
Min	10.5	19.9	29.8	39.0	48.6
Max	10.9	20.8	30.7	40.6	50.0
Avg	10.67	20.33	30.13	39.57	49.23

✦ Indicates energized contacts

✦ Indicates thermocouple monitored, energized contacts

✦	✦		
✦	✦		

252369
6 (2x3) Power Pins Powered in Series
Part Numbers: LPHS-08-32-L-VP1-GP / LPHT-08-32-L-RT1-GP

Current Rating per Contact (30 Deg. Rise, 20% Derated) = 25.3 Amps

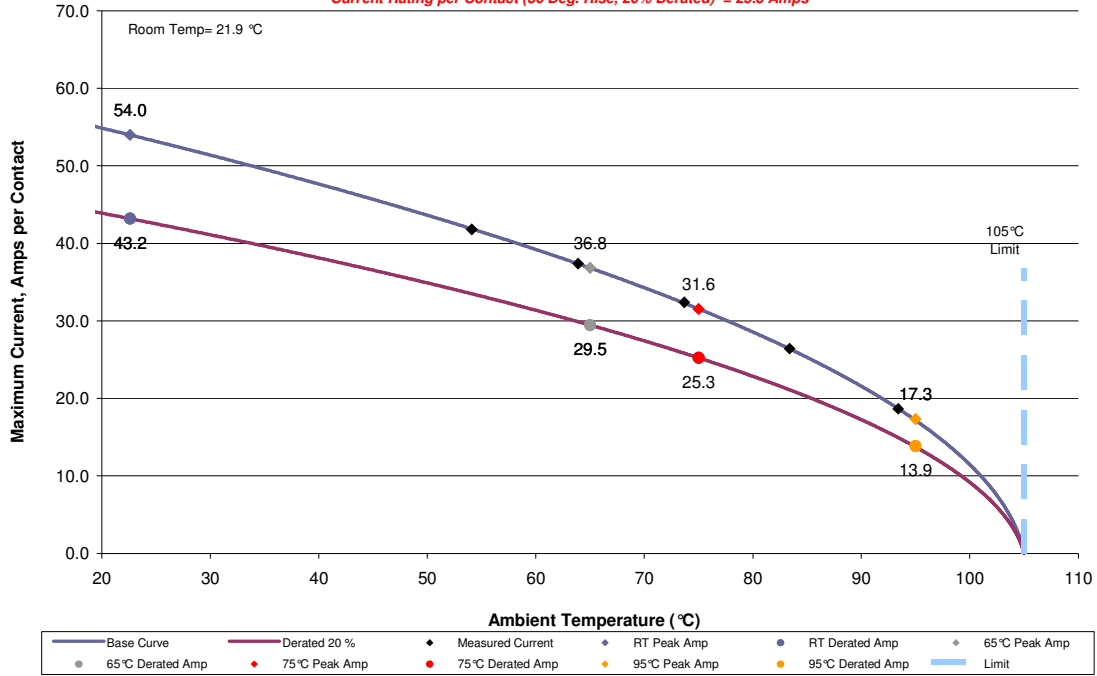

252369
6 (2x3) Power Pins Powered in Series
Part Numbers: LPHS-08-32-L-VP1-GP / LPHT-08-32-L-RT1-GP

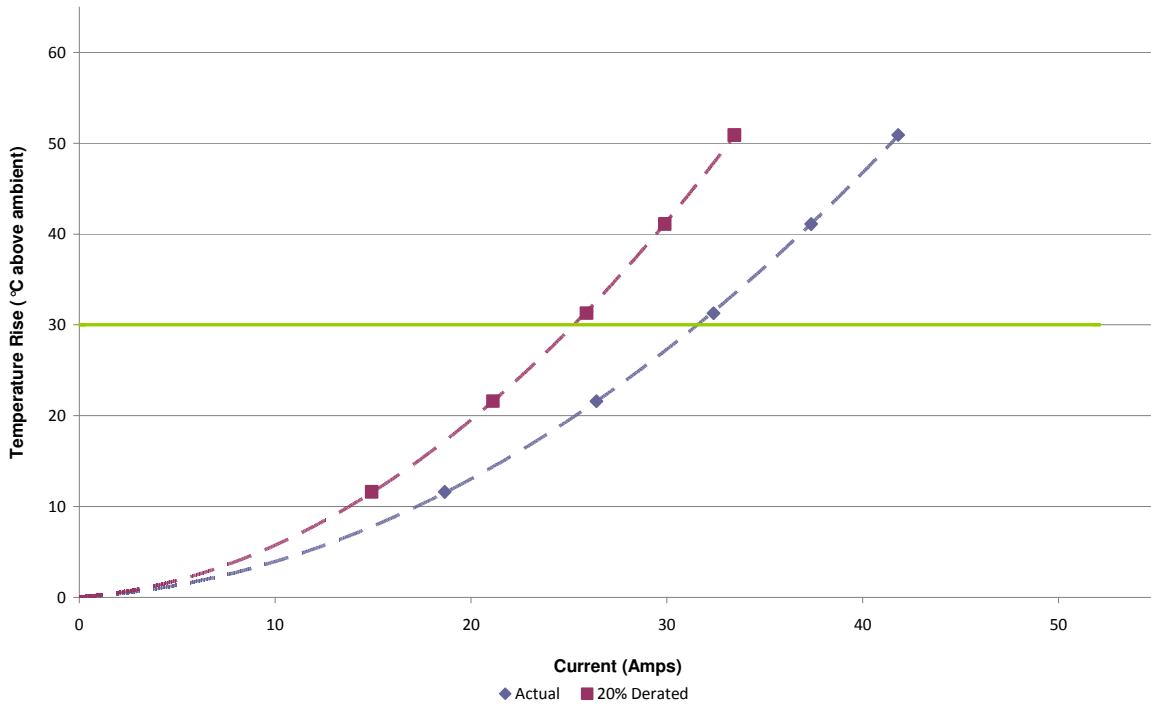



POWER INTEGRITY TEST REPORT

252369
INITIAL RELEASE

TEMPERATURE RISE DATA SIX CONTACTS ENERGIZED (Degrees Celsius above ambient)

TEST CURRENT AMPS	18.67	26.42	32.4	37.38	41.82
Sample 7	12.2	22.9	33.1	43.0	53.2
Sample 8	11.6	21.9	32.4	42.2	53.3
Sample 9	11.0	20.0	28.4	38	46.3
Min	11.0	20.0	28.4	38.0	46.3
Max	12.2	22.9	33.1	43.0	53.3
Avg	11.6	21.6	31.3	41.07	50.93

✦ Indicates energized contacts

✦ Indicates thermocouple monitored, energized contacts

✦	✦	✦	
✦	✦	✦	

252369
8 (All Power) Power Pins Powered in Series
Part Numbers: LPHS-08-32-L-VP1-GP / LPHT-08-32-L-RT1-GP

Current Rating per Contact (30 Deg. Rise, 20% Derated) = 23.6 Amps

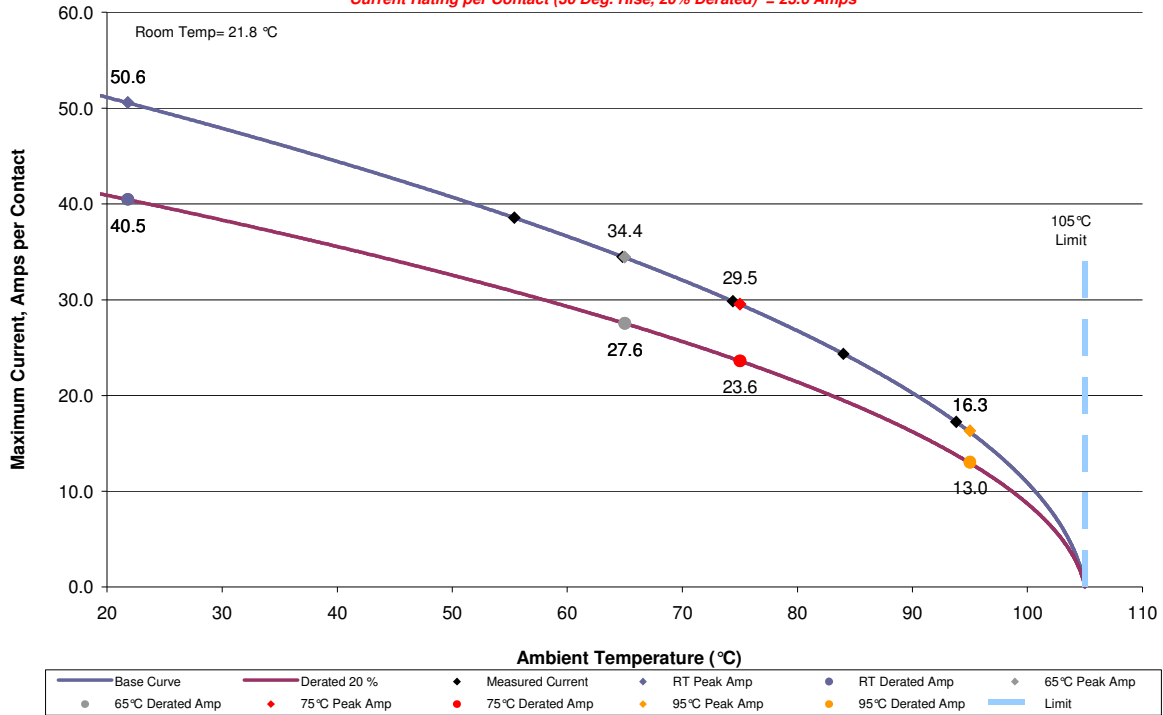

252369
8 (All Power) Power Pins Powered in Series
Part Numbers: LPHS-08-32-L-VP1-GP / LPHT-08-32-L-RT1-GP

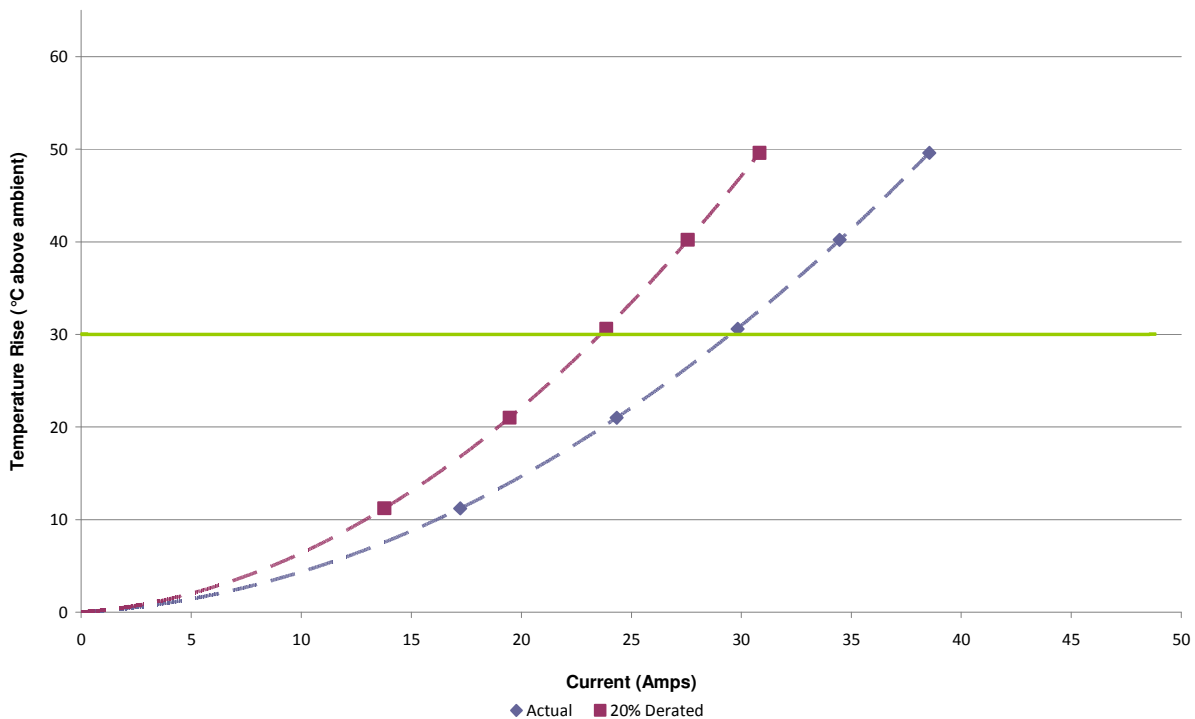



POWER INTEGRITY TEST REPORT

252369

INITIAL RELEASE

TEMPERATURE RISE DATA EIGHT CONTACTS ENERGIZED (Degrees Celsius above ambient)

TEST CURRENT AMPS	17.23	24.34	29.84	34.47	38.55
Sample 10	10.9	20.6	30.3	43.1	49.1
Sample 11	11.9	22.3	32.1	45.9	52.2
Sample 12	10.8	20.1	29.5	43.1	47.6
Min	10.8	20.1	29.5	43.1	47.6
Max	11.9	22.3	32.1	45.9	52.2
Avg	11.2	21	30.63	44.03	49.63

✦ Indicates energized contacts

✦ Indicates thermocouple monitored, energized contacts

✦	✦	✦	✦
✦	✦	✦	✦

252369
2 (2x1) Signal Pins Powered in Series
Part Numbers: LPHS-08-32-L-VP1-GP / LPHT-08-32-L-RT1-GP

Current Rating per Contact (30 Deg. Rise, 20% Derated) = 2.5 Amps

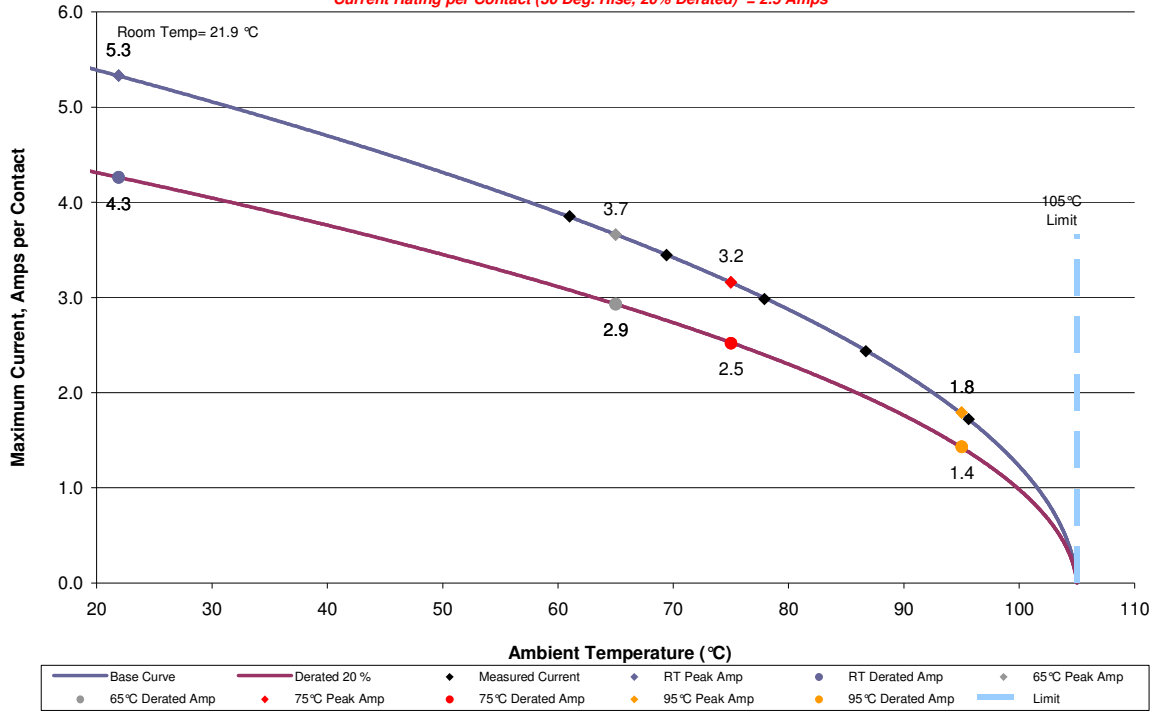

252369
2 (2x1) Signal Pins Powered in Series
Part Numbers: LPHS-08-32-L-VP1-GP / LPHT-08-32-L-RT1-GP

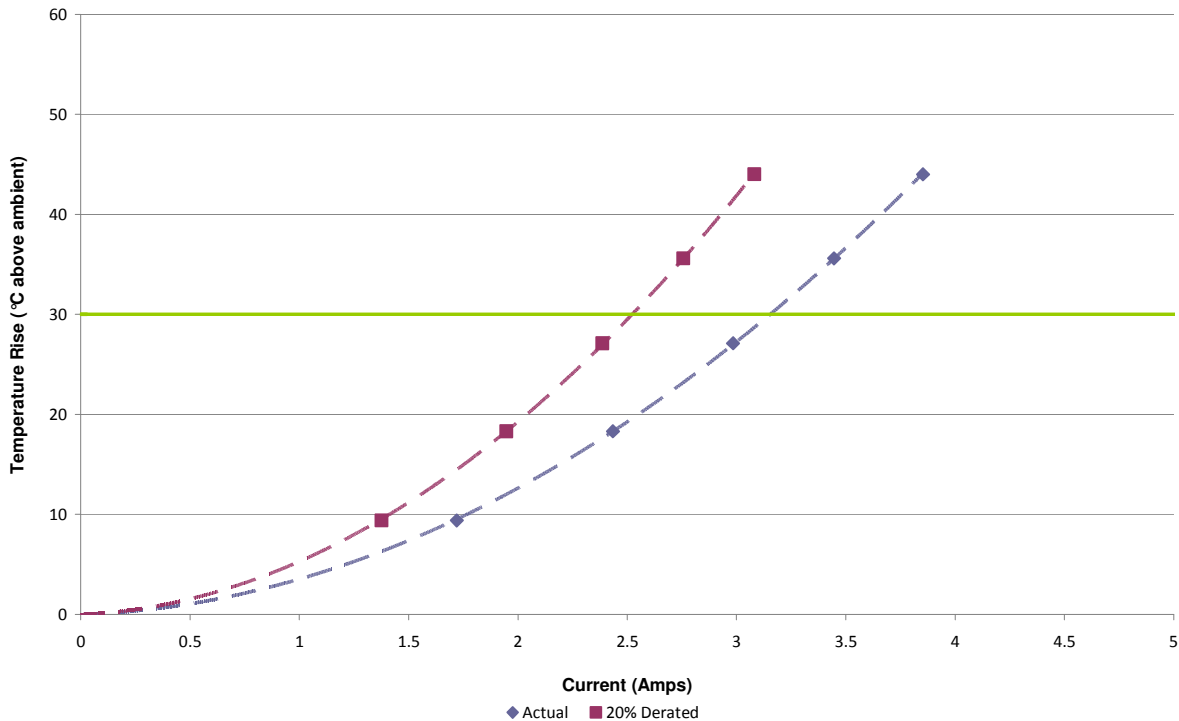



POWER INTEGRITY TEST REPORT

252369

INITIAL RELEASE

TEMPERATURE RISE DATA ALL CONTACTS ENERGIZED (Degrees Celsius above ambient)

TEST CURRENT AMPS	1.72	2.43	2.98	3.45	3.85
Sample 13	31.8	41.0	50.0	58.9	67.5
Sample 14	31.4	40.4	49.3	58.1	66.7
Sample 15	30.8	39.3	47.7	55.9	63.9
Min	30.80	39.30	47.70	55.90	63.90
Max	31.80	41.00	50.00	58.90	67.50
Avg	31.33	40.23	49.00	57.63	66.03

✦ Indicates energized contacts

✦ Indicates thermocouple monitored, energized contacts

✦			
✦			

252369
4 (2x2) Signal Pins Powered in Series
Part Numbers: LPHS-08-32-L-VP1-GP / LPHT-08-32-L-RT1-GP

Current Rating per Contact (30 Deg. Rise, 20% Derated) = 2.1 Amps

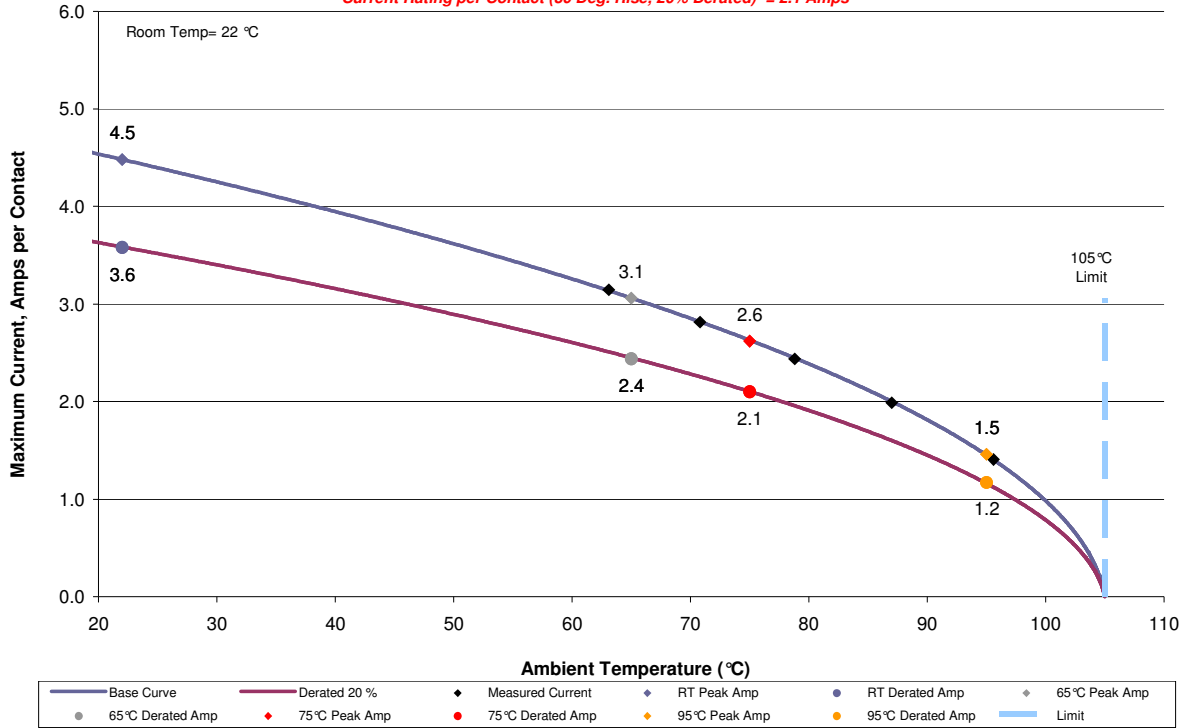

252369
4 (2x2) Signal Pins Powered in Series
Part Numbers: LPHS-08-32-L-VP1-GP / LPHT-08-32-L-RT1-GP

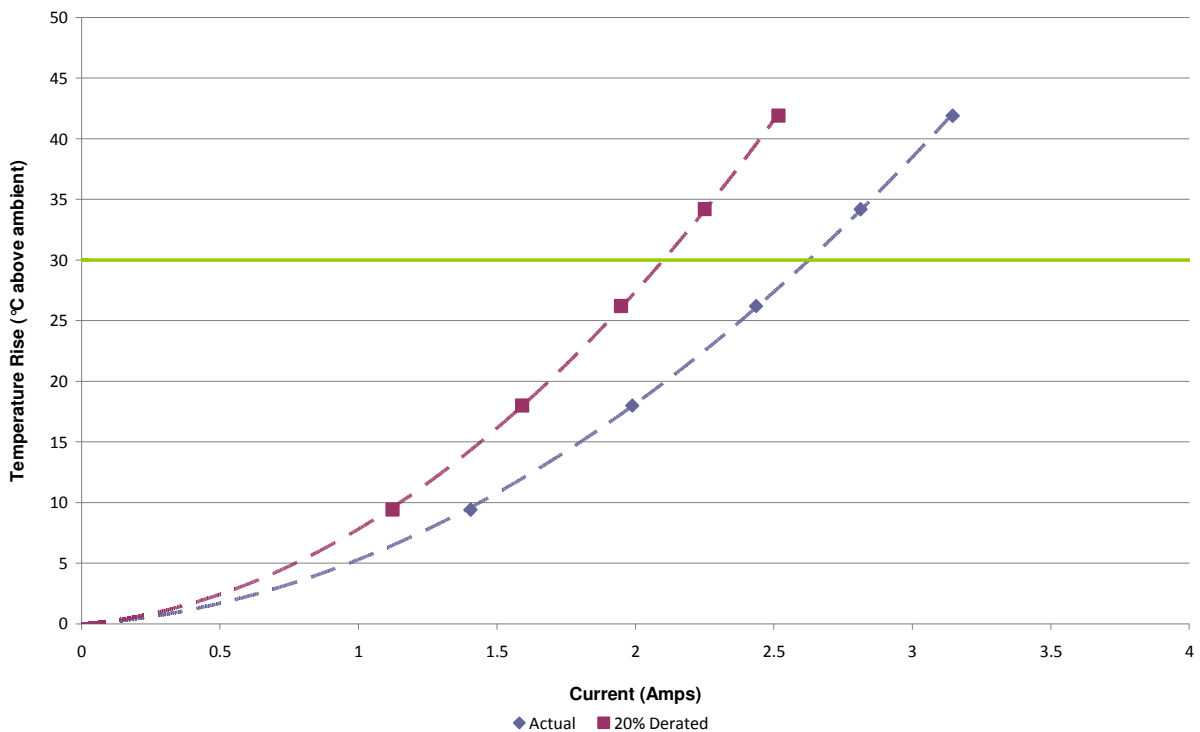



**POWER INTEGRITY TEST
REPORT**

252369
INITIAL RELEASE

**TEMPERATURE RISE DATA
ALL CONTACTS ENERGIZED
(Degrees Celsius above ambient)**

TEST CURRENT AMPS	1.40	1.99	2.44	2.81	3.15
Sample 16	31.3	39.8	48.1	56.3	64.5
Sample 17	31.2	39.8	48.2	56.5	64.6
Sample 18	31.8	40.4	48.3	55.8	62.7
Min	31.20	39.80	48.10	55.80	62.70
Max	31.80	40.40	48.30	56.50	64.60
Avg	31.43	40.00	48.20	56.20	63.93

✦ Indicates energized contacts

✦ Indicates thermocouple monitored, energized contacts

✦	✦		
✦	✦		

252369
6 (2x3) Signal Pins Powered in Series
Part Numbers: LPHS-08-32-L-VP1-GP / LPHT-08-32-L-RT1-GP

Current Rating per Contact (30 Deg. Rise, 20% Derated) = 1.8 Amps

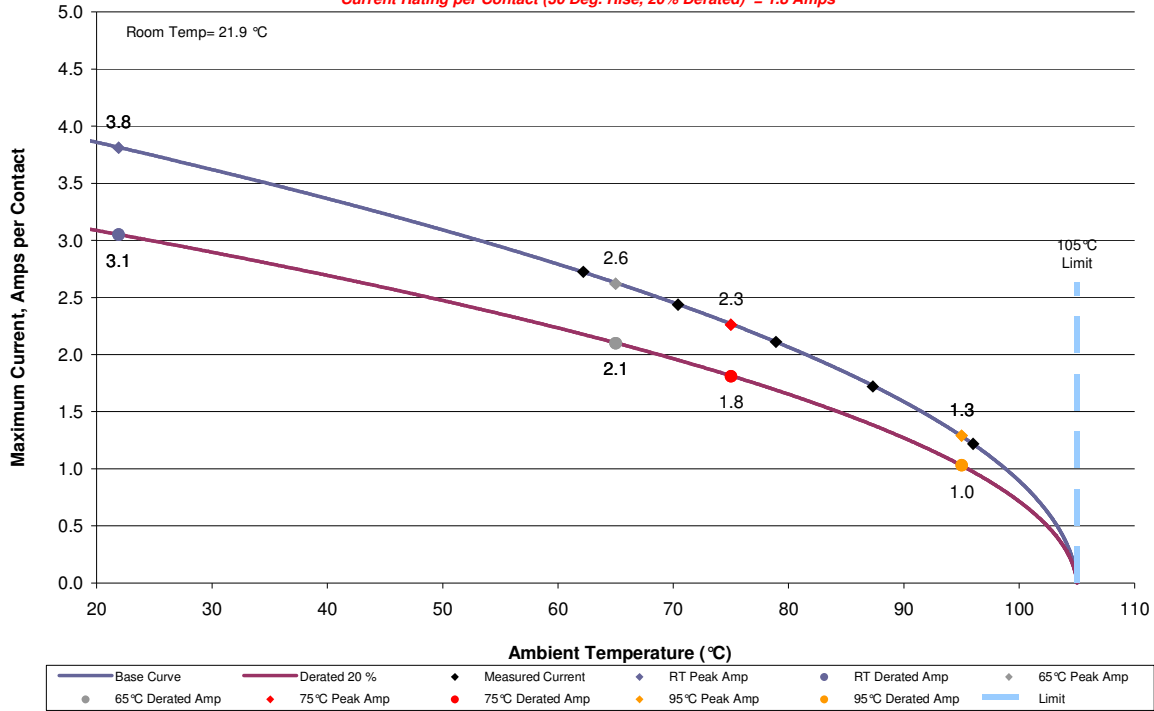

252369
6 (2x3) Signal Pins Powered in Series
Part Numbers: LPHS-08-32-L-VP1-GP / LPHT-08-32-L-RT1-GP

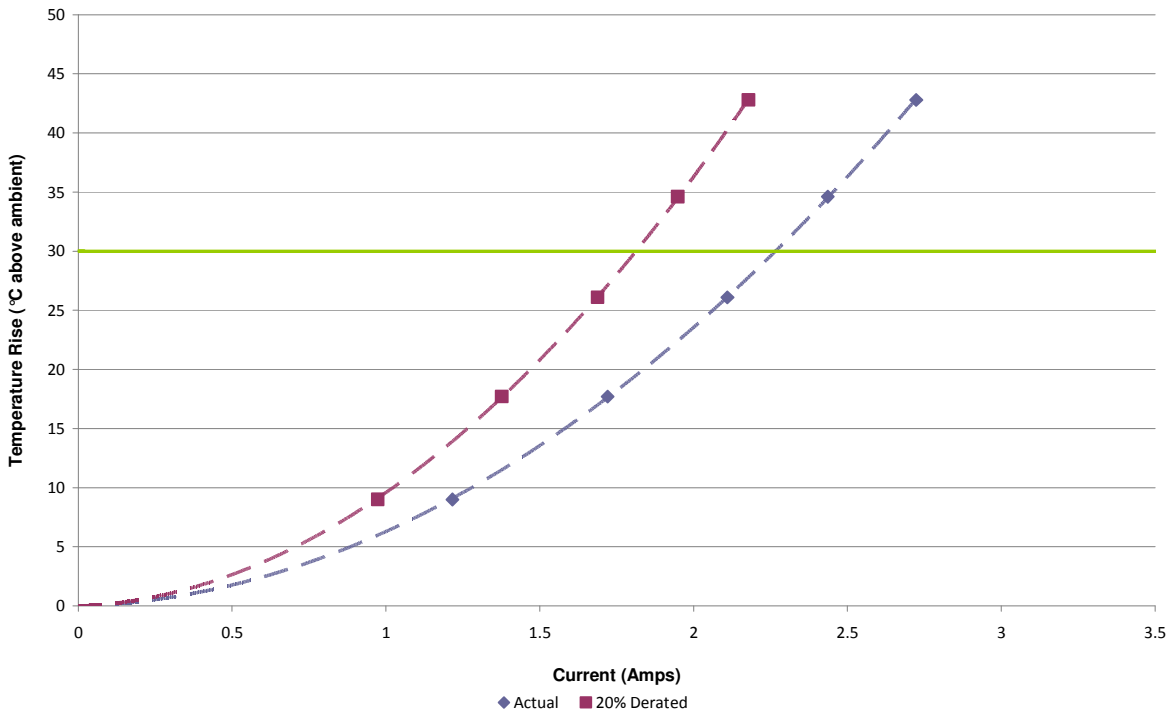



**POWER INTEGRITY TEST
REPORT**

252369
INITIAL RELEASE

**TEMPERATURE RISE DATA
ALL CONTACTS ENERGIZED
(Degrees Celsius above ambient)**

TEST CURRENT AMPS	1.22	1.72	2.11	2.44	2.73
Sample 19	31.2	40.1	48.8	57.4	65.7
Sample 20	30.5	38.8	47.0	55.2	63.2
Sample 21	31.1	39.8	48.3	56.8	65.1
Min	30.50	38.80	47.00	55.20	63.20
Max	31.20	40.10	48.80	57.40	65.70
Avg	30.93	39.57	48.03	56.47	64.67

✦ Indicates energized contacts

✦ Indicates thermocouple monitored, energized contacts

✦	✦	✦	
✦	✦	✦	

252369
8 (2x4) Signal Pins Powered in Series
Part Numbers: LPHS-08-32-L-VP1-GP / LPHT-08-32-L-RT1-GP

Current Rating per Contact (30 Deg. Rise, 20% Derated) = 1.7 Amps

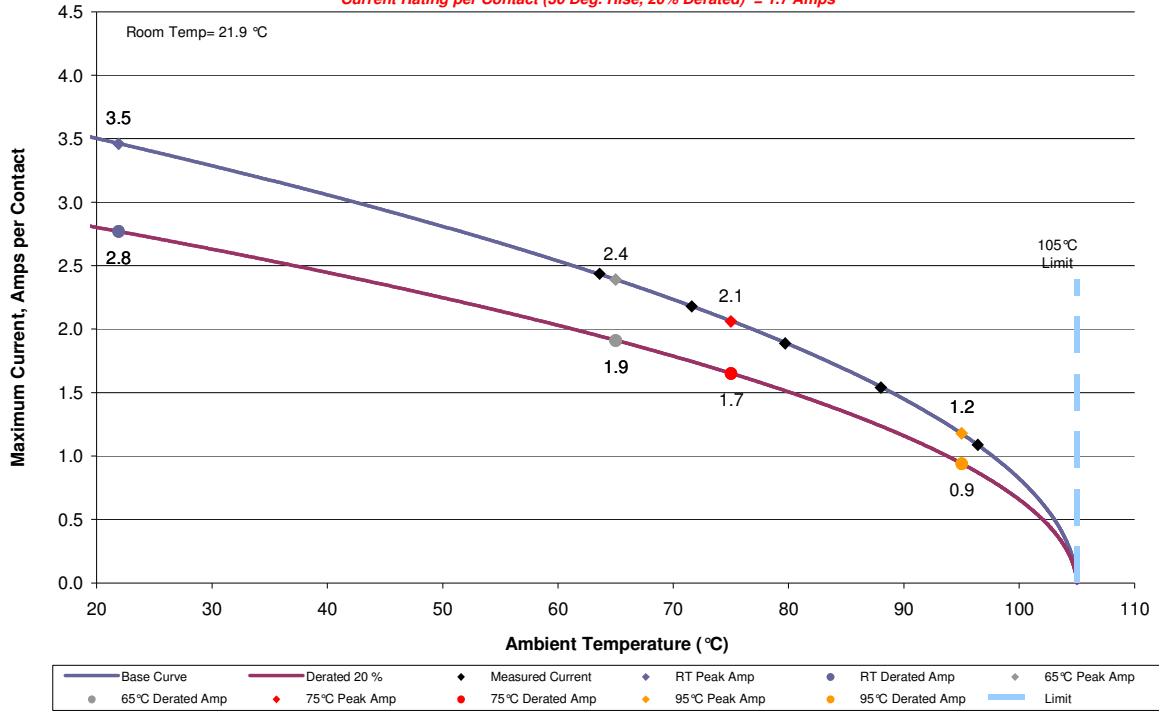

252369
8 (2x4) Signal Pins Powered in Series
Part Numbers: LPHS-08-32-L-VP1-GP / LPHT-08-32-L-RT1-GP

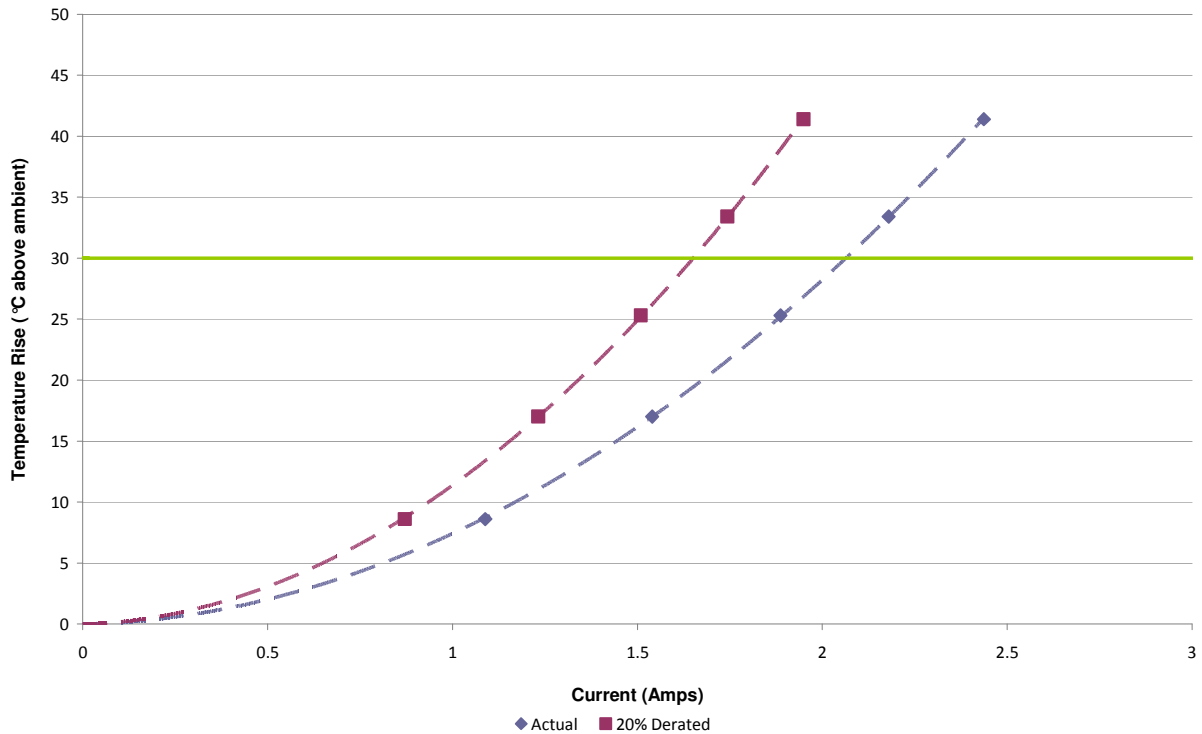



POWER INTEGRITY TEST REPORT

252369
INITIAL RELEASE

TEMPERATURE RISE DATA ALL CONTACTS ENERGIZED (Degrees Celsius above ambient)

TEST CURRENT AMPS	1.09	1.54	1.89	2.18	2.44
Sample 22	36.0	38.6	46.6	54.5	62.3
Sample 23	36.2	38.9	47.1	55.1	63.1
Sample 24	36.7	39.6	48.1	56.6	64.7
Min	36.00	38.60	46.60	54.50	62.30
Max	36.70	39.60	48.10	56.60	64.70
Avg	36.30	39.03	47.27	55.40	63.37

✦ Indicates energized contacts

✦ Indicates thermocouple monitored, energized contacts

✦	✦	✦	✦
✦	✦	✦	✦

252369
32 (All Power) Signal Pins Powered in Series
Part Numbers: LPHS-08-32-L-VP1-GP / LPHT-08-32-L-RT1-GP

Current Rating per Contact (30 Deg. Rise, 20% Derated) = 1.0 Amps

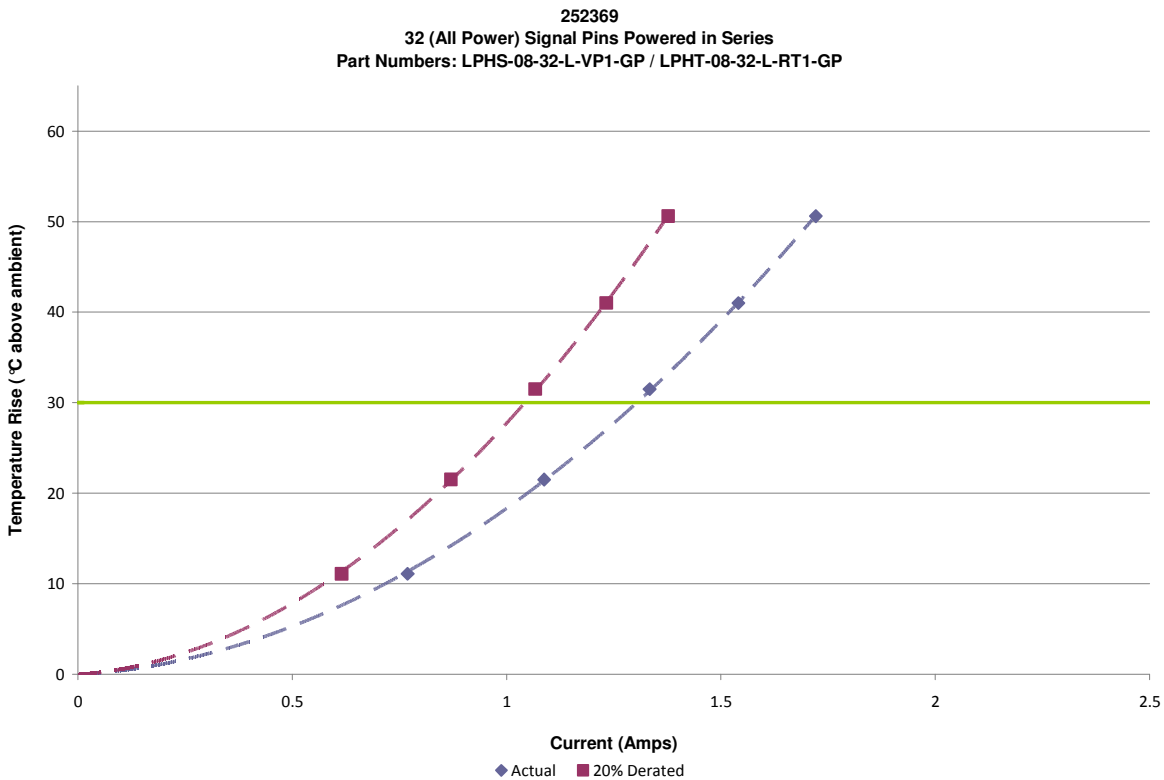
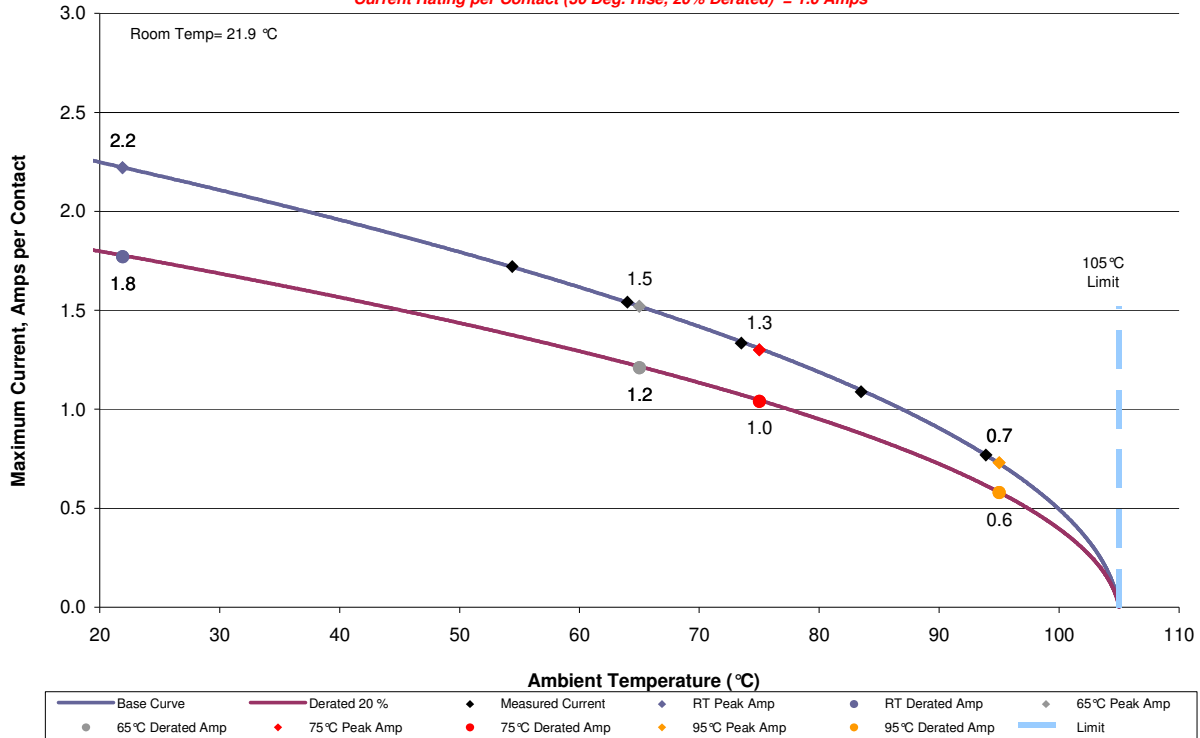

**TEMPERATURE RISE DATA
ALL CONTACTS ENERGIZED
(Degrees Celsius above ambient)**

TEST CURRENT AMPS	0.77	1.09	1.33	1.54	1.72
Sample 25	32.8	43.3	53.5	62.8	72.9
Sample 26	33.1	43.6	53.7	63.4	73.1
Sample 27	33.1	43.3	53	62.5	71.6
Min	32.80	43.30	53.00	62.50	71.60
Max	33.10	43.60	53.70	63.40	73.10
Avg	33.00	43.40	53.40	62.90	72.53

- ✦ Indicates energized contacts
- ✦ Indicates thermocouple monitored, energized contacts

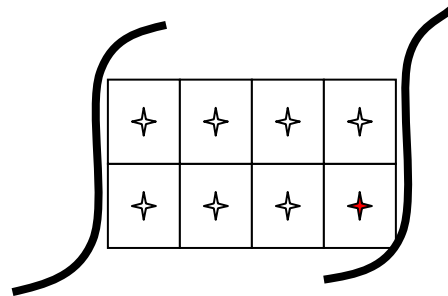

252369
8 (All Power) Power Pins Powered in Series (Signal Pins powered at 1/2 rated current - .65 amps)
Part Numbers: LPHS-08-32-L-VP1-GP / LPHT-08-32-L-RT1-GP

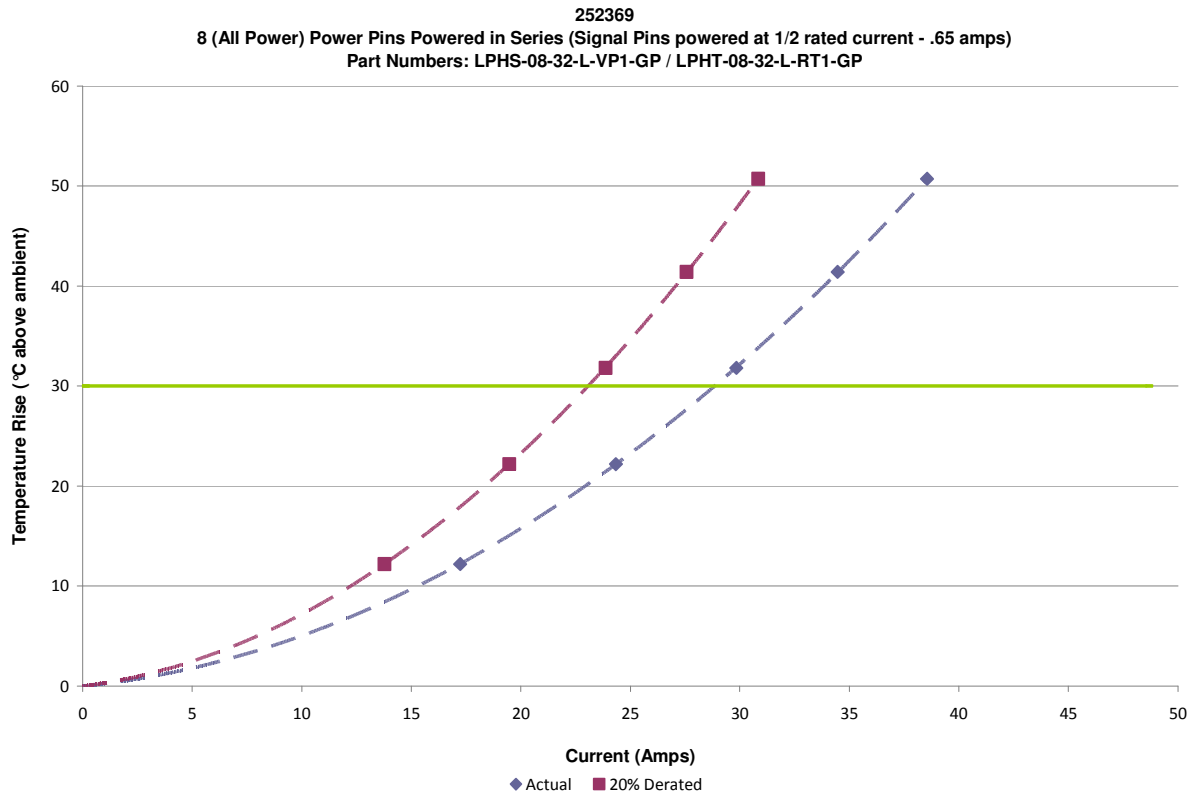
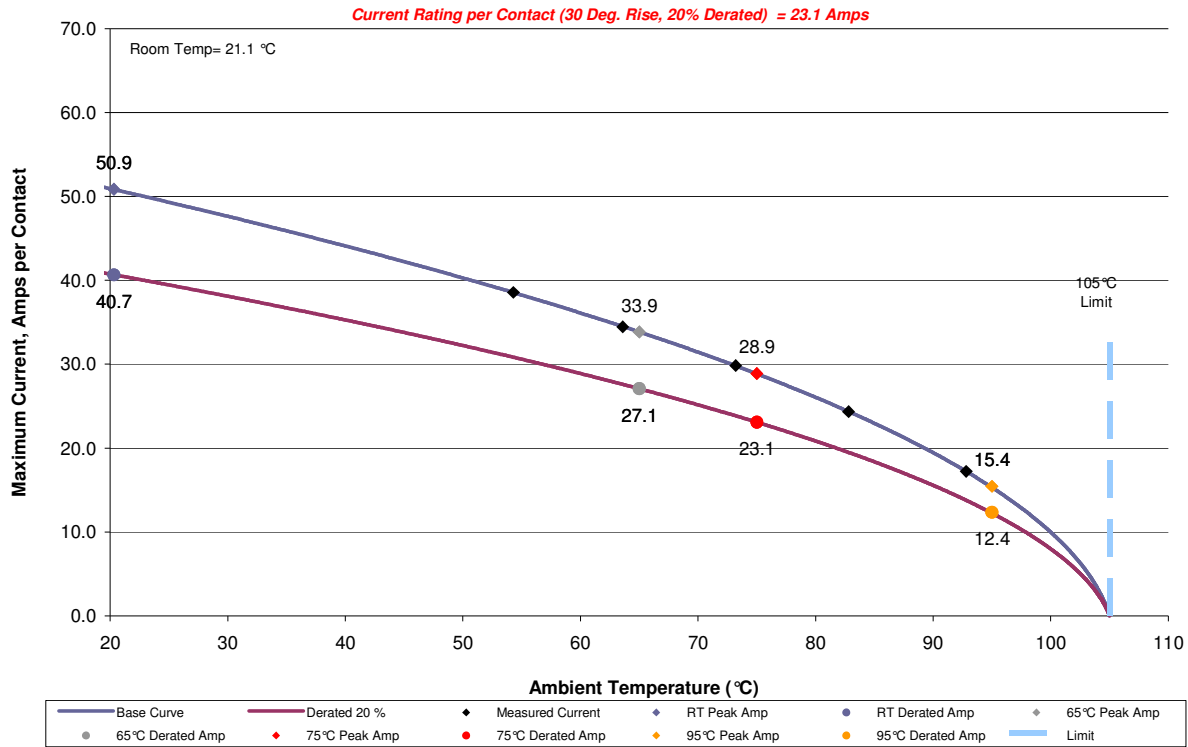

**TEMPERATURE RISE DATA
ALL CONTACTS ENERGIZED
(Degrees Celsius above ambient)**

TEST CURRENT AMPS	17.23	24.34	29.84	34.46	38.55
Sample 28	32.3	42.7	52.7	62.9	72.5
Sample 29	32.7	43.0	53.2	63.0	72.5
Sample 30	32.4	42.8	52.5	62.2	72.2
Min	32.30	42.70	52.50	62.20	72.20
Max	32.70	43.00	53.20	63.00	72.50
Avg	32.47	42.83	52.80	62.70	72.40

- ✦ Indicates energized contacts
- ✦ Indicates thermocouple monitored, energized contacts

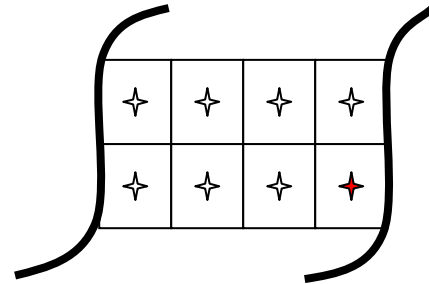

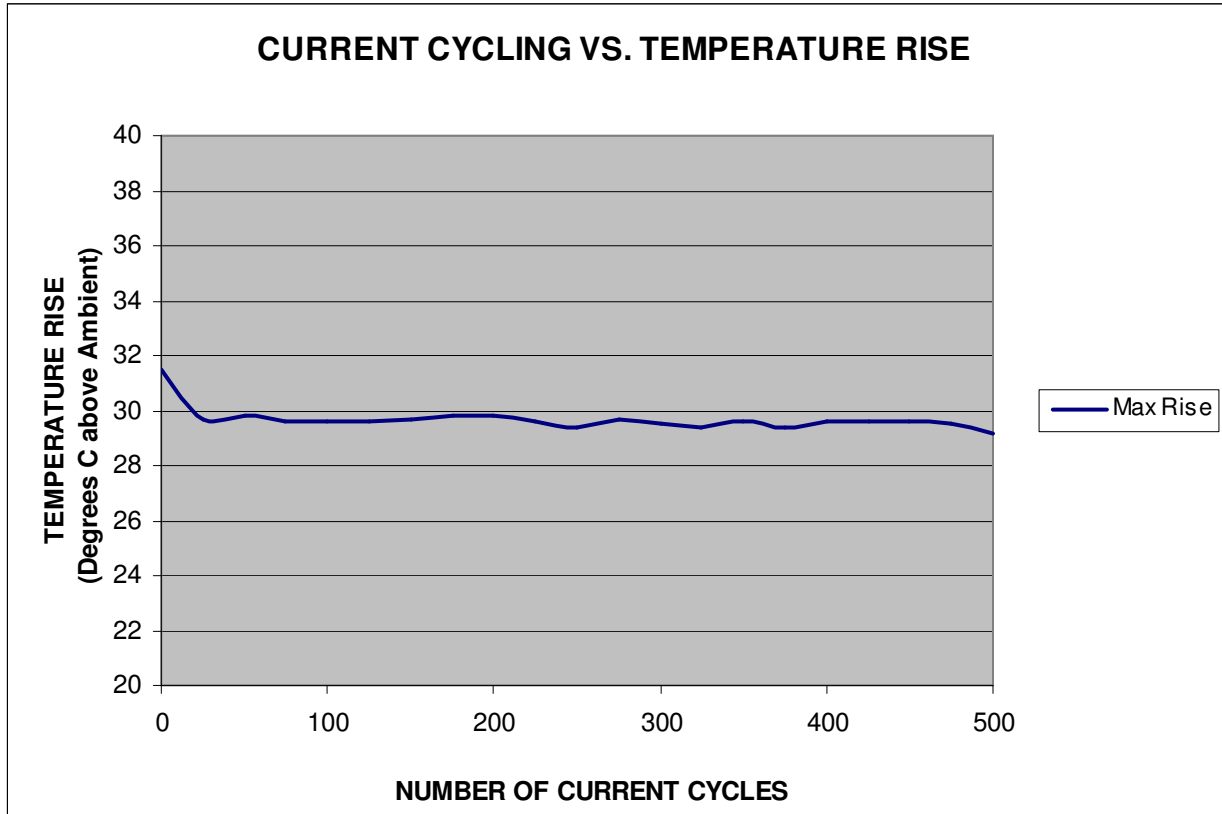

**TEMPERATURE RISE DATA
ALL CONTACTS ENERGIZED
(Degrees Celsius above ambient)**

	INITIAL	50 CYCLES	100 CYCLES	200 CYCLES	500 CYCLES
Min	28.5	26.7	26.5	26.5	26
Max	31.5	29.8	29.6	29.8	29.2
Avg	29.6	27.8	27.8	27.7	27.4

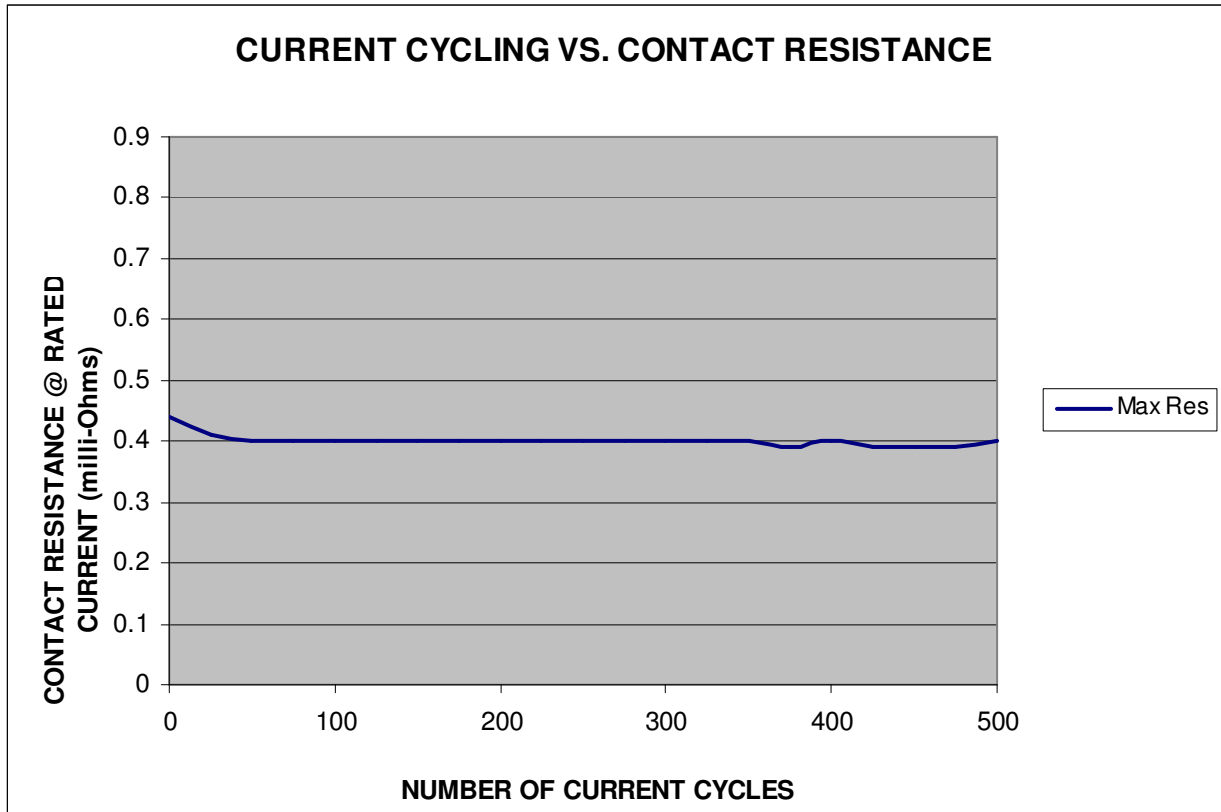

**CONTACT RESISTANCE DATA
ALL CONTACTS ENERGIZED
(mΩ)**

	INITIAL	50 CYCLES	100 CYCLES	200 CYCLES	500 CYCLES
Min	0.20	0.19	0.19	0.19	0.19
Max	0.44	0.40	0.40	0.40	0.40
Avg	0.27	0.25	0.25	0.25	0.24

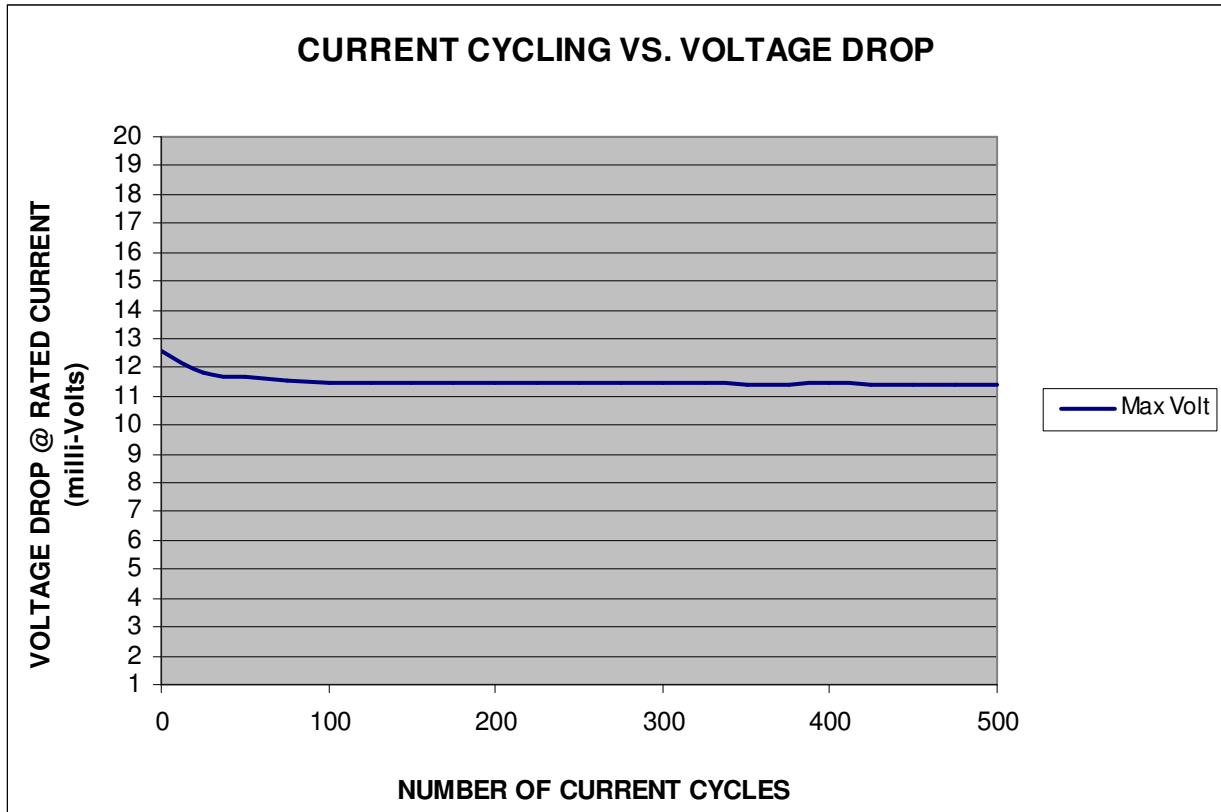

**VOLTAGE DROP DATA
ALL CONTACTS ENERGIZED
(MV)**

	INITIAL	50 CYCLES	100 CYCLES	200 CYCLES	500 CYCLES
Min	5.92	5.5	5.46	5.45	5.39
Max	12.61	11.67	11.5	11.49	11.42
Avg	7.83	7.22	7.14	7.12	7.05



**POWER INTEGRITY TEST
REPORT**

252369

INITIAL RELEASE

EQUIPMENT AND CALIBRATION SCHEDULES

Equipment #: MO-04

Description: Multimeter /Data Acquisition System

Manufacturer: Keithley

Model: 2700

Serial #: 0798688

Accuracy: See Manual

... Last Cal: 04/30/2013, Next Cal: 04/30/2014

Equipment #: PS-07

Description: 20 V, 120 A DC Power Supply - AutoRanging SO/HPIB

Manufacturer: Hewlett Packard / Agilent

Model: AT-6031A

Serial #: 2721A00648

Accuracy: See Manual

... Last Cal: Reference Only, Next Cal: Reference Only

Equipment #: MO-09

Description: Model 2750 Multimeter/Switch System

Manufacturer: Keithley

Model: 2750

Serial #: WDC-874817

Accuracy: See Manual

... Last Cal: 10/20/2012, Next Cal: 10/20/2013

Equipment #: PS-09

Description: 60 V, 50 A DC Power Supply - AutoRanging SO

Manufacturer: Hewlett Packard / Agilent

Model: AT-6032A

Serial #: US38322853

Accuracy: See Manual

... Last Cal: Reference Only, Next Cal: Reference Only