

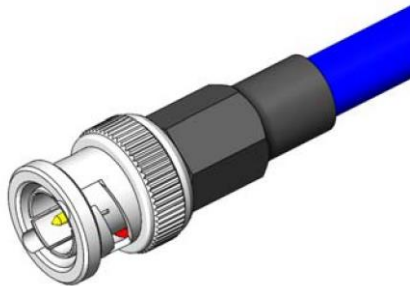

Project Number: Design Qualification Test Report	Tracking Code: 2854151_Report_Rev_1
Requested by: Joe Huang	Date: 10/20/2021
Part #: BNC7T-J-P-GN-RA-BM1D/RFB6T-D4SP3-505050-0153	Tech: Peter Chen
Part description: BNC7T / RFB6T	Qty to test: 30
Test Start: 07/05/2021	Test Completed: 08/09/2021

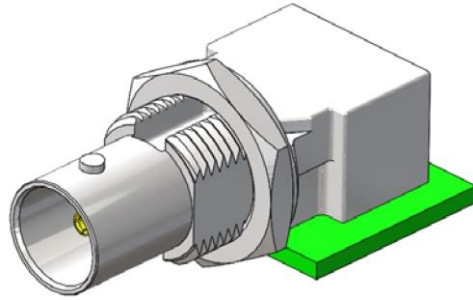

DESIGN QUALIFICATION TEST REPORT

BNC7T / RFB6T

BNC7T-J-P-GN-RA-BM1D/RFB6T-D4SP3-505050-0153

Tracking Code: 2854151_Report_Rev_1	Part #: BNC7T-J-P-GN-RA-BM1D/RFB6T-D4SP3-505050-0153
Part description: BNC7T / RFB6T	

REVISION HISTORY

DATA	REV.NUM.	DESCRIPTION	ENG
8/30/2021	1	Initial Issue	PC

CERTIFICATION

All instruments and measuring equipment were calibrated to National Institute for Standards and Technology (NIST) traceable standards according to ISO 10012-1 and ANSI/NCSL 2540-1, as applicable.

All contents contained herein are the property of Samtec. No portion of this report, in part or in full shall be reproduced without prior written approval of Samtec.

SCOPE

To perform the following tests: Design Qualification test. Please see test plan.

APPLICABLE DOCUMENTS

Standards: EIA Publication 364

TEST SAMPLES AND PREPARATION

- 1) All materials were manufactured in accordance with the applicable product specification.
- 2) All test samples were identified and encoded to maintain traceability throughout the test sequences.
- 3) After soldering, the parts to be used for LLCR and DWV/IR testing were cleaned according to TLWI-0001.
- 4) Either an automated cleaning procedure or an ultrasonic cleaning procedure may be used.
- 5) The automated procedure is used with aqueous compatible soldering materials.
- 6) Parts not intended for testing LLCR and DWV/IR are visually inspected and cleaned if necessary.
- 7) Any additional preparation will be noted in the individual test sequences.
- 8) Solder Information: Lead Free
- 9) Samtec Test PCBs used: PCB-109089-TST

FLOWCHARTS

Thermal Aging

Group 1

BNC7T-J-P-GN-RA-BM1D
RFB6T-D4SP3-505050-0153
8 Assemblies

Step	Description
1.	Contact Gaps <i>Note: Signal and ground.</i>
2.	LLCR ⁽¹⁾ <i>Note: Signal and ground.</i>
3.	Thermal Age ⁽²⁾
4.	LLCR ⁽¹⁾ Max Delta = 15 mOhm <i>Note: Signal and ground.</i>
5.	Contact Gaps <i>Note: Signal and ground.</i>

(1) LLCR = EIA-364-23

Open Circuit Voltage = 20 mV Max
Test Current = 100 mA Max

(2) Thermal Age = EIA-364-17

Test Condition = 4 (105°C)
Time Condition = B (250 Hours)

FLOWCHARTS Continued**Mating/Unmating/Durability**Group 1

BNC7T-J-P-GN-RA-BM1D

RFB6T-D4SP3-505050-0153

8 Assemblies

Step Description

1. Contact Gaps
Note: Signal and ground.
2. LLCR (2)
Note: Signal and ground.
3. Cycles
Quantity = 500 Cycles
Note: By hand
4. Contact Gaps
Note: Signal and ground.
5. LLCR (2)
Max Delta = 15 mOhm
Note: Signal and ground.
6. Thermal Shock (3)
7. LLCR (2)
Max Delta = 15 mOhm
Note: Signal and ground.
8. Humidity (1)
9. LLCR (2)
Max Delta = 15 mOhm
Note: Signal and ground.

(1) Humidity = EIA-364-31

Test Condition = B (240 Hours)

Test Method = III (+25°C to +65°C @ 90% RH to 98% RH)

Test Exceptions: ambient pre-condition and delete steps 7a and 7b

(2) LLCR = EIA-364-23

Open Circuit Voltage = 20 mV Max

Test Current = 100 mA Max

(3) Thermal Shock = EIA-364-32

Exposure Time at Temperature Extremes = 1/2 Hour

Method A, Test Condition = I (-55°C to +85°C)

Test Duration = A-3 (100 Cycles)

FLOWCHARTS Continued**IR/DWV****Pin-to-Ground****Group 1**

BNC7T-J-P-GN-RA-BM1D
RFB6T-D4SP3-505050-0153
2 Assemblies

Group 2

BNC7T-J-P-GN-RA-BM1D

2 Assemblies

Group 3

RFB6T-D4SP3-505050-0153
2 Assemblies

Group 4

BNC7T-J-P-GN-RA-BM1D
RFB6T-D4SP3-505050-0153
2 Assemblies

Step	Description
1.	DWV Breakdown ⁽²⁾

Step	Description
1.	DWV Breakdown ⁽²⁾

Step	Description
1.	DWV Breakdown ⁽²⁾

Step	Description
1.	IR ⁽⁴⁾
2.	DWV at Test Voltage ⁽¹⁾
3.	Thermal Shock ⁽⁵⁾
4.	IR ⁽⁴⁾
5.	DWV at Test Voltage ⁽¹⁾
6.	Humidity ⁽³⁾
7.	IR ⁽⁴⁾
8.	DWV at Test Voltage ⁽¹⁾

(1) DWV at Test Voltage = EIA-364-20

Test Condition = 1 (Sea Level)

DWV test voltage is equal to 75% of the lowest breakdown voltage

Test voltage applied for 60 seconds

(2) DWV Breakdown = EIA-364-20

Test Condition = 1 (Sea Level)

DWV test voltage is equal to 75% of the lowest breakdown voltage

Test voltage applied for 60 seconds

(3) Humidity = EIA-364-31

Test Condition = B (240 Hours)

Test Method = III (+25°C to +65°C @ 90% RH to 98% RH)

Test Exceptions: ambient pre-condition and delete steps 7a and 7b

(4) IR = EIA-364-21

Test Condition = 500 Vdc, 2 Minutes Max

(5) Thermal Shock = EIA-364-32

Exposure Time at Temperature Extremes = 1/2 Hour

Method A, Test Condition = I (-55°C to +85°C)

Test Duration = A-3 (100 Cycles)

FLOWCHARTS Continued**Mechanical Shock/Random Vibration/LLCR**Group 1

BNC7T-J-P-GN-RA-BM1D
RFB6T-D4SP3-505050-0410
8 Assemblies

Step Description

1. LLCR ⁽¹⁾
Note: Signal and ground.
2. Mechanical Shock ⁽²⁾
3. Random Vibration ⁽³⁾
4. LLCR ⁽¹⁾
Max Delta = 15 mOhm
Note: Signal and ground.

(1) LLCR = EIA-364-23

Open Circuit Voltage = 20 mV Max
Test Current = 100 mA Max

(2) Mechanical Shock = EIA-364-27

Test Condition = C (100 G Peak, 6 milliseconds, Half Sine)
Number of Shocks = 3 Per Direction, Per Axis, 18 Total

(3) Random Vibration = EIA-364-28

Condition = VB (7.56 gRMS Average, 2 Hours/Axis)

Mechanical Shock/Random Vibration/Event DetectionGroup 1

BNC7T-J-P-GN-RA-BM1D
RFB6T-D4SP3-505050-0410
8 Assemblies

Step Description

1. Nanosecond Event Detection
(Mechanical Shock) ⁽¹⁾
2. Nanosecond Event Detection
(Random Vibration) ⁽²⁾

(1) Nanosecond Event Detection (Mechanical Shock)

Use EIA-364-87 for Nanosecond Event Detection:
Test Condition = F (50 nanoseconds at 10 ohms)

Use EIA-364-27 for Mechanical Shock:
Test Condition = C (100 G Peak, 6 milliseconds, Half Sine)
Number of Shocks = 3 Per Direction, Per Axis, 18 Total

(2) Nanosecond Event Detection (Random Vibration)

Use EIA-364-87 for Nanosecond Event Detection:
Test Condition = F (50 nanoseconds at 10 ohms)

Use EIA-364-28 for Random Vibration:
Condition = VB (7.56 gRMS Average, 2 Hours/Axis)

FLOWCHARTS Continued**PUSH**

Note: Push to destruct and measure force

Group 1
BNC7T-J-P-GN-RA-BM1D

5 Assemblies

Step	Description
1.	0 Degree Push On Center Contact

Group 2
BNC7T-J-P-GN-RA-BM1D

5 Assemblies

Step	Description
1.	90 Degree Push On Center Contact

ATTRIBUTE DEFINITIONS

The following is a brief, simplified description of attributes.

THERMAL:

- 1) EIA-364-17, *Temperature Life with or without Electrical Load Test Procedure for Electrical Connectors*.
- 2) Test Condition :105° C.
- 3) Test Time Condition B for 250 hours.
- 4) All test samples are pre-conditioned at ambient.
- 5) All test samples are exposed to environmental stressing in the mated condition.

THERMAL SHOCK:

- 1) EIA-364-32, *Thermal Shock (Temperature Cycling) Test Procedure for Electrical Connectors*.
- 2) Test Condition 1: -55°C to +85°C
- 3) Test Time: ½ hour dwell at each temperature extreme
- 4) Number of Cycles: 100
- 5) All test samples are pre-conditioned at ambient.
- 6) All test samples are exposed to environmental stressing in the mated condition.

HUMIDITY:

- 1) Reference document: EIA-364-31, *Humidity Test Procedure for Electrical Connectors*.
- 2) Test Condition B, 240 Hours.
- 3) Method III, +25° C to + 65° C, 90% to 98% Relative Humidity excluding sub-cycles 7a and 7b.
- 4) All samples are pre-conditioned at ambient.
- 5) All test samples are exposed to environmental stressing in the mated condition.

MECHANICAL SHOCK (Specified Pulse):

- 1) Reference document: EIA-364-27, *Mechanical Shock Test Procedure for Electrical Connectors*
- 2) Test Condition C
- 3) Peak Value: 100 G
- 4) Duration: 6 Milliseconds
- 5) Wave Form: Half Sine
- 6) Velocity: 12.3 ft/s
- 7) Number of Shocks: 3 Shocks / Direction, 3 Axis (18 Total)

VIBRATION:

- 1) Reference document: EIA-364-28, *Vibration Test Procedure for Electrical Connectors*
- 2) Test Condition V, Letter B
- 3) Power Spectral Density: 0.04 G² / Hz
- 4) G 'RMS': 7.56
- 5) Frequency: 50 to 2000 Hz
- 6) Duration: 2.0 Hours per axis (3 axis total)

NANOSECOND-EVENT DETECTION:

- 1) Reference document: EIA-364-87, *Nanosecond-Event Detection for Electrical Connectors*
- 2) Prior to test, the samples were characterized to assure the low nanosecond event being monitored will trigger the detector.
- 3) After characterization it was determined the test samples could be monitored for 50 nanosecond events

MATING/UNMATING:

- 1) Reference document: EIA-364-13, *Mating and Unmating Forces Test Procedure for Electrical Connectors*.
- 2) The full insertion position was to within 0.003" to 0.004" of the plug bottoming out in the receptacle to prevent damage to the system under test.
- 3) One of the mating parts is secured to a floating X-Y table to prevent damage during cycling.

ATTRIBUTE DEFINITIONS Continued

The following is a brief, simplified description of attributes

LLCR:

- 1) EIA-364-23, *Low Level Contact Resistance Test Procedure for Electrical Connectors and Sockets*.
- 2) A computer program, *LLCR 221.exe*, ensures repeatability for data acquisition.
- 3) The following guidelines are used to categorize the changes in LLCR as a result from stressing

Signal pin:

- a. $\leq +5.0$ mOhms: -----Stable
- b. $+5.1$ to $+10.0$ mOhms:-----Minor
- c. $+10.1$ to $+15.0$ mOhms: -----Acceptable
- d. $+15.1$ to $+50.0$ mOhms: -----Marginal
- e. $+50.1$ to $+1000$ mOhms: -----Unstable
- f. $>+1000$ mOhms:-----Open Failure

GND Pin:

- g. $\leq +0.33$ mOhms: -----Stable
- h. $+0.33$ to $+0.66$ mOhms: -----Minor
- i. $+0.67$ to $+1.00$ mOhms: -----Acceptable
- j. $+1.01$ to $+50.0$ mOhms: -----Marginal
- k. $+50.1$ to $+1000$ mOhms: -----Unstable
- l. $>+1000$ mOhms:-----Open Failure

INSULATION RESISTANCE (IR):

To determine the resistance of insulation materials to leakage of current through or on the surface of these materials when a DC potential is applied.

- 1) PROCEDURE:
 - a. Reference document: EIA-364-21, *Insulation Resistance Test Procedure for Electrical Connectors*.
 - b. Test Conditions:
 - i. Between Adjacent Contacts or Signal-to-Ground
 - ii. Electrification Time 2.0 minutes
 - iii. Test Voltage (500 VDC) corresponds to calibration settings for measuring resistances.
- 2) MEASUREMENTS:
- 3) When the specified test voltage is applied (VDC), the insulation resistance shall not be less than 1000 megohms.

DIELECTRIC WITHSTANDING VOLTAGE (DWV):

To determine if the sockets can operate at its rated voltage and withstand momentary over potentials due to switching, surges, and other similar phenomenon. Separate samples are used to evaluate the effect of environmental stresses so not to influence the readings from arcing that occurs during the measurement process.

- 1) PROCEDURE:
 - a. Reference document: EIA-364-20, *Withstanding Voltage Test Procedure for Electrical Connectors*.
 - b. Test Conditions:
 - i. Between Adjacent Contacts or Signal-to-Ground
 - ii. Barometric Test Condition 1
 - iii. Rate of Application 500 V/Sec
 - iv. Test Voltage (VAC) until breakdown occurs
- 2) MEASUREMENTS/CALCULATIONS
 - a. The breakdown voltage shall be measured and recorded.
 - b. The dielectric withstanding voltage shall be recorded as 75% of the minimum breakdown voltage.
 - c. The working voltage shall be recorded as one-third (1/3) of the dielectric withstanding voltage (one-fourth of the breakdown voltage).

ATTRIBUTE DEFINITIONS Continued

The following is a brief, simplified description of attributes

PUSH FORCE:

Push to destruct and measure force

- a. At 0 Degrees
- b. At 90 Degrees



Fig -1 0 degrees



Fig -2 90 degrees

RESULTS**Push force**

- **0° Push**
 - **Min** -----19.67 lbs
 - **Max** -----26.04 lbs
- **90° Push**
 - **Min** ----- 4.76 lbs
 - **Max** ----- 5.12 lbs

Insulation Resistance minimums, IR**Pin to GND**

- **Initial**
 - **Mated** ----- 450000 Meg Ω ----- Passed
 - **Unmated** ----- 450000 Meg Ω ----- Passed
- **Thermal Shock**
 - **Mated** ----- 450000 Meg Ω ----- Passed
 - **Unmated** ----- 450000 Meg Ω ----- Passed
- **Humidity**
 - **Mated** ----- 450000 Meg Ω ----- Passed
 - **Unmated** ----- 450000 Meg Ω ----- Passed

Dielectric Withstanding Voltage minimums, DWV

- **Minimums**
 - **Breakdown Voltage** ----- 3034 VAC
 - **Test Voltage** ----- 2280 VAC
 - **Working Voltage** ----- 755 VAC

Pin to GND

- **Initial DWV** -----Passed
- **Thermal DWV** -----Passed
- **Humidity DWV** -----Passed

RESULTS Continued**LLCR Thermal Aging (16 LLCR test points)****Signal Pin**

- **Initial** -----7.14 mOhms Max
- **Thermal Aging**
 - <= +5.0 mOhms-----8 Points ----- Stable
 - +5.1 to +10.0 mOhms -----0 Points ----- Minor
 - +10.1 to +15.0 mOhms -----0 Points ----- Acceptable
 - +15.1 to +50.0 mOhms -----0 Points ----- Marginal
 - +50.1 to +1000 mOhms-----0 Points ----- Unstable
 - >+1000 mOhms-----0 Points ----- Open Failure

Ground Pin

- **Initial** -----1.98 mOhms Max
- **Thermal Aging**
 - <= +0.33 mOhms ----- 8 Points ----- Stable
 - +0.34 to +0.66 mOhms -----0 Points ----- Minor
 - +0.67 to +1.00 mOhms -----0 Points ----- Acceptable
 - +1.01 to +50.0 mOhms -----0 Points ----- Marginal
 - +50.1 to +1000 mOhms-----0 Points ----- Unstable
 - >+1000 mOhms-----0 Points ----- Open Failure

LLCR Durability (16 LLCR test points)**Signal Pin**

- **Initial** -----7.95 mOhms Max
- **Durability, 500 Cycles**
 - <= +5.0 mOhms-----8 Points ----- Stable
 - +5.1 to +10.0 mOhms -----0 Points ----- Minor
 - +10.1 to +15.0 mOhms -----0 Points ----- Acceptable
 - +15.1 to +50.0 mOhms -----0 Points ----- Marginal
 - +50.1 to +1000 mOhms-----0 Points ----- Unstable
 - >+1000 mOhms-----0 Points ----- Open Failure
- **Thermal Shock**
 - <= +5.0 mOhms-----8 Points ----- Stable
 - +5.1 to +10.0 mOhms -----0 Points ----- Minor
 - +10.1 to +15.0 mOhms -----0 Points ----- Acceptable
 - +15.1 to +50.0 mOhms -----0 Points ----- Marginal
 - +50.1 to +1000 mOhms-----0 Points ----- Unstable
 - >+1000 mOhms-----0 Points ----- Open Failure
- **Humidity**
 - <= +0.33 mOhms ----- 8 Points ----- Stable
 - +0.34 to +0.66 mOhms -----0 Points ----- Minor
 - +0.67 to +1.00 mOhms -----0 Points ----- Acceptable
 - +1.01 to +50.0 mOhms -----0 Points ----- Marginal
 - +50.1 to +1000 mOhms-----0 Points ----- Unstable
 - >+1000 mOhms-----0 Points ----- Open Failure

RESULTS Continued**Ground Pin**

- **Initial** -----2.19 mOhms Max
- **Durability, 500 Cycles**
 - <= +0.33 mOhms ----- 8 Points ----- Stable
 - +0.34 to +0.66 mOhms ----- 0 Points ----- Minor
 - +0.67 to +1.00 mOhms ----- 0 Points ----- Acceptable
 - +1.01 to +50.0 mOhms ----- 0 Points ----- Marginal
 - +50.1 to +1000 mOhms ----- 0 Points ----- Unstable
 - >+1000 mOhms ----- 0 Points ----- Open Failure
- **Thermal Shock**
 - <= +0.33 mOhms ----- 5 Points ----- Stable
 - +0.34 to +0.66 mOhms ----- 3 Points ----- Minor
 - +0.67 to +1.00 mOhms ----- 0 Points ----- Acceptable
 - +1.01 to +50.0 mOhms ----- 0 Points ----- Marginal
 - +50.1 to +1000 mOhms ----- 0 Points ----- Unstable
 - >+1000 mOhms ----- 0 Points ----- Open Failure
- **Humidity**
 - <= +0.33 mOhms ----- 2 Points ----- Stable
 - +0.34 to +0.66 mOhms ----- 1 Points ----- Minor
 - +0.67 to +1.00 mOhms ----- 5 Points ----- Acceptable
 - +1.01 to +50.0 mOhms ----- 0 Points ----- Marginal
 - +50.1 to +1000 mOhms ----- 0 Points ----- Unstable
 - >+1000 mOhms ----- 0 Points ----- Open Failure

LLCR Shock & Vibration Group (16 LLCR test points)**Signal Pin**

- **Initial** ----- 12.91 mOhms Max
- **Shock & Vibration**
 - <= +5.0 mOhms ----- 8 Points ----- Stable
 - +5.1 to +10.0 mOhms ----- 0 Points ----- Minor
 - +10.1 to +15.0 mOhms ----- 0 Points ----- Acceptable
 - +15.1 to +50.0 mOhms ----- 0 Points ----- Marginal
 - +50.1 to +1000 mOhms ----- 0 Points ----- Unstable
 - >+1000 mOhms ----- 0 Points ----- Open Failure

Ground Pin

- **Initial** -----4.15 mOhms Max
- **Shock & Vibration**
 - <= +0.33 mOhms ----- 8 Points ----- Stable
 - +0.34 to +0.66 mOhms ----- 0 Points ----- Minor
 - +0.67 to +1.00 mOhms ----- 0 Points ----- Acceptable
 - +1.01 to +50.0 mOhms ----- 0 Points ----- Marginal
 - +50.1 to +1000 mOhms ----- 0 Points ----- Unstable
 - >+1000 mOhms ----- 0 Points ----- Open Failure

Mechanical Shock & Random Vibration:

- **Shock**
 - **No Damage**----- Pass
 - **50 Nanoseconds**----- Pass
- **Vibration**
 - **No Damage**----- Pass
 - **50 Nanoseconds**----- Pass

DATA SUMMARIES**Push Force**

0 Degrees

	Force (lbs)
Minimum	19.67
Maximum	26.04
Average	23.61

90 Degrees

	Force (lbs)
Minimum	4.76
Maximum	5.12
Average	5.02

INSULATION RESISTANCE (IR):

	Pin to Pin		
	Mated	Unmated	Unmated
Minimum	BNC7T/RFB6T	BNC7T	RFB6T
Initial	45000	45000	45000
Thermal	45000	45000	45000
Humidity	45000	45000	45000

DIELECTRIC WITHSTANDING VOLTAGE (DWV):

Voltage Rating Summary	
Minimum	BNC7T/RFB6T
Break Down Voltage	3034
Test Voltage	2280
Working Voltage	755

Pin to GND	
Initial Test Voltage	Passed
After Thermal Test Voltage	Passed
After Humidity Test Voltage	Passed

DATA SUMMARIES Continued**LLCR Thermal Aging:**

- 1) A total of 16 points were measured.
- 2) EIA-364-23, *Low Level Contact Resistance Test Procedure for Electrical Connectors and Sockets*.
- 3) A computer program, *LLCR 221.exe*, ensures repeatability for data acquisition.
- 4) The following guidelines are used to categorize the changes in LLCR as a result from stressing.
 - a. $\leq +5.0$ mOhms: -----Stable
 - b. $+5.1$ to $+10.0$ mOhms: -----Minor
 - c. $+10.1$ to $+15.0$ mOhms:-----Acceptable
 - d. $+15.1$ to $+50.0$ mOhms:-----Marginal
 - e. $+50.1$ to $+1000$ mOhms-----Unstable
 - f. $>+1000$ mOhms:-----Open Failure

LLCR Measurement Summaries by Pin Type				
Date	7/9/2021	7/20/2021		
Room Temp (Deg C)	23	23		
Rel Humidity (%)	54	54		
Technician	Peter Chen	Peter Chen		
mOhm values	Actual Initial	Delta Thermal	Delta	Delta
Pin Type 1: Ground				
Average	1.89	0.12		
St. Dev.	0.06	0.10		
Min	1.79	0.00		
Max	1.98	0.31		
Summary Count	8	8		
Total Count	8	8		
Pin Type 2: Signal				
Average	7.00	0.06		
St. Dev.	0.09	0.05		
Min	6.91	0.01		
Max	7.14	0.14		
Summary Count	8	8		
Total Count	8	8		

Signal Pin

LLCR Delta Count by Category						
mOhms	Stable	Minor	Acceptable	Marginal	Unstable	Open
	≤ 5	>5 & ≤ 10	>10 & ≤ 15	>15 & ≤ 50	>50 & ≤ 1000	>1000
Thermal	8	0	0	0	0	0

GND Pin

LLCR Delta Count by Category						
mOhms	Stable	Minor	Acceptable	Marginal	Unstable	Open
	≤ 0.33	>0.33 & ≤ 0.66	>0.66 & ≤ 1	>1 & ≤ 50	>50 & ≤ 1000	>1000
Thermal	8	0	0	0	0	0

DATA SUMMARIES Continued

LLCR Durability:

- 4) A total of 16 points were measured.
- 5) EIA-364-23, *Low Level Contact Resistance Test Procedure for Electrical Connectors and Sockets*.
- 6) A computer program, *LLCR 221.exe*, ensures repeatability for data acquisition.
- 4) The following guidelines are used to categorize the changes in LLCR as a result from stressing.
 - a. $\leq +5.0$ mOhms: -----Stable
 - b. $+5.1$ to $+10.0$ mOhms: -----Minor
 - c. $+10.1$ to $+15.0$ mOhms: -----Acceptable
 - d. $+15.1$ to $+50.0$ mOhms: -----Marginal
 - e. $+50.1$ to $+1000$ mOhms -----Unstable
 - f. $>+1000$ mOhms: -----Open Failure

LLCR Measurement Summaries by Pin Type				
Date	7/9/2021	7/15/2021	7/27/2021	8/8/2021
Room Temp (Deg C)	23	23	23	23
Rel Humidity (%)	54	54	54	54
Technician	Peter Chen	Peter Chen	Peter Chen	Peter Chen
mOhm values	Actual Initial	Delta After cycle	Delta After Thermal	Delta After Humidity
Pin Type 1: Ground				
Average	2.06	0.10	0.26	0.60
St. Dev.	0.10	0.05	0.11	0.18
Min	1.92	0.04	0.11	0.35
Max	2.19	0.18	0.44	0.91
Summary Count	8	8	8	8
Total Count	8	8	8	8
Pin Type 2: Signal				
Average	7.13	0.20	0.09	0.15
St. Dev.	0.33	0.26	0.07	0.07
Min	6.85	0.01	0.01	0.07
Max	7.95	0.84	0.25	0.25
Summary Count	8	8	8	8
Total Count	8	8	8	8

Signal Pin

LLCR Delta Count by Category						
	Stable	Minor	Acceptable	Marginal	Unstable	Open
mOhms	≤ 5	$>5 \ \& \ \leq 10$	$>10 \ \& \ \leq 15$	$>15 \ \& \ \leq 50$	$>50 \ \& \ \leq 1000$	>1000
After cycle	8	0	0	0	0	0
After Thermal	8	0	0	0	0	0
After Humidity	8	0	0	0	0	0

GND Pin

LLCR Delta Count by Category						
	Stable	Minor	Acceptable	Marginal	Unstable	Open
mOhms	≤ 0.33	$>0.33 \ \& \ \leq 0.66$	$>0.66 \ \& \ \leq 1$	$>1 \ \& \ \leq 50$	$>50 \ \& \ \leq 1000$	>1000
After Cycles	8	0	0	0	0	0
Therm Shck	5	3	0	0	0	0
Humidity	2	1	5	0	0	0

DATA SUMMARIES Continued

LLCR Shock & Vibration

- 1) A total of 16 points were measured.
- 2) EIA-364-23, *Low Level Contact Resistance Test Procedure for Electrical Connectors and Sockets*.
- 3) A computer program, *LLCR 221.exe*, ensures repeatability for data acquisition.
- 4) The following guidelines are used to categorize the changes in LLCR as a result from stressing.
 - a. $\leq +5.0$ mOhms: -----Stable
 - b. $+5.1$ to $+10.0$ mOhms: -----Minor
 - c. $+10.1$ to $+15.0$ mOhms: -----Acceptable
 - d. $+15.1$ to $+50.0$ mOhms: -----Marginal
 - e. $+50.1$ to $+1000$ mOhms: -----Unstable
 - f. $>+1000$ mOhms: -----Open Failure

		LLCR Measurement Summaries by Pin Type		
		7/27/2021	7/29/2021	
Date		7/27/2021	7/29/2021	
Room Temp (Deg C)		23	23	
Rel Humidity (%)		47	50	
Technician		John Crawford	John Crawford	
mOhm values		Actual	Delta	
		Initial	Shock-Vib	
Pin Type: Signal 1				
Average		12.71	0.44	
St. Dev.		0.14	1	
Min		12.53	0.01	
Max		12.91	2.91	
Summary Count		8	8	
Total Count		8	8	
Pin Type: GND 1				
Average		4.02	0.07	
St. Dev.		0.08	0.07	
Min		3.88	0	
Max		4.15	0.24	
Summary Count		8	8	
Total Count		8	8	

Signal Pin

LLCR Delta Count by Category						
	Stable	Minor	Acceptable	Marginal	Unstable	Open
mOhms	≤ 5	$>5 \ \& \ \leq 10$	$>10 \ \& \ \leq 15$	$>15 \ \& \ \leq 50$	$>50 \ \& \ \leq 1000$	>1000
Shock-Vib	8	0	0	0	0	0

GND Pin

LLCR Delta Count by Category						
	Stable	Minor	Acceptable	Marginal	Unstable	Open
mOhms	≤ 0.33	$>0.33 \ \& \ \leq 0.66$	$>0.66 \ \& \ \leq 1$	$>1 \ \& \ \leq 50$	$>50 \ \& \ \leq 1000$	>1000
Shock-Vib	8	0	0	0	0	0

DATA SUMMARIES Continued**Nanosecond Event Detection:**

Shock and Vibration Event Detection Summary	
Contacts tested	16
Test Condition	C, 100g's, 6ms, Half-Sine
Shock Events	108
Test Condition	V-B, 7.56 rms g
Vibration Events	108
Total Events	216

EQUIPMENT AND CALIBRATION SCHEDULES

Equipment #: HZ-HPM-01
Description: Hipot Megommeter
Manufacturer: Hipotronics
Model: H306B-A
Serial #: M9905004
Accuracy: 2 % Full Scale Accuracy
... Last Cal: 2021-4-27, Next Cal: 2022-4-26

Equipment #: HZ-MO-03
Description: Micro-ohmmeter
Manufacturer: Keithley
Model: 580
Serial #: 297288
Accuracy: Last Cal: 2021-8-06, Next Cal: 2022-8-05

Equipment #: HZ-THC-01
Description: Humidity transmitter
Manufacturer: Thermtron
Model: HMM30C
Serial #: D0240037
Accuracy: Last Cal: 2021-3-3, Next Cal: 2022-3-2

Equipment #: HZ-PS-01
Description: Power Supply
Manufacturer: Agilent
Model: 6031A
Serial #: MY41000982
Accuracy: Last Cal: 2021-4-28, Next Cal: 2022-4-27

Equipment #: HZ-TSC-01
Description: Thermal Shock transmitter
Manufacturer: Keithley
Model: 10-VT14994
Serial #: VTS-3-6-6-SC/AC
Accuracy: Last Cal: 2020-11-1, Next Cal: 2021-11-1

Equipment #: HZ-OV-01
Description: Oven
Manufacturer: Huida
Model: CS101-1E
Serial #: CS101-1E-B
Accuracy: Last Cal: 2020-12-14, Next Cal: 2021-12-13

EQUIPMENT AND CALIBRATION SCHEDULES**Equipment #:** SVC-01**Description:** Shock & Vibration Table**Manufacturer:** Data Physics**Model:** LE-DSA-10-20K**Serial #:** 10037**Accuracy:** Last Cal: 2020-11-31, Next Cal: 2021-11-31**Equipment #:** ACLM-01**Description:** Accelerometer**Manufacturer:** PCB Piezotronics**Model:** 352C03**Serial #:** 115819**Accuracy:** Last Cal: 2021-07-09, Next Cal: 2022-07-09**Equipment #:** ED-03**Description:** Event Detector**Manufacturer:** Analysis Tech**Model:** 32EHD**Serial #:** 1100604**Accuracy:** Last Cal: 2021-06-04, Next Cal: 2022-06-04