

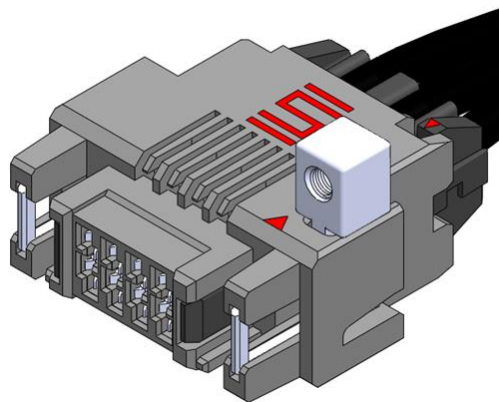

Project Number: Design Qualification Test Report	Tracking Code: 3467354_Report_Rev_1
Requested by: Roy Luo	Date: 12/12/2022
Part #: UMPE-04-T-16-12.0/UMPI-04-T-16-12.0	
Part description: UMPE/UMPI	Tech: Kason He
Test Start: 9/2/2022	Test Completed: 10/13/2022

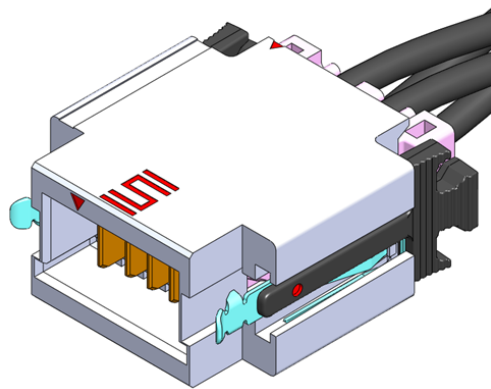

## DESIGN QUALIFICATION TEST REPORT

UMPE/UMPI  
UMPE-04-T-16-12.0/UMPI-04-T-16-12.0

**REVISION HISTORY**

<b>DATA</b>	<b>REV.NUM.</b>	<b>DESCRIPTION</b>	<b>ENG</b>
12/12/2022	1	Initial Issue	KH

## CERTIFICATION

All instruments and measuring equipment were calibrated to National Institute for Standards and Technology (NIST) traceable standards according to ISO 10012-1 and ANSI/NCSL 2540-1, as applicable.

All contents contained herein are the property of Samtec. No portion of this report, in part or in full shall be reproduced without prior written approval of Samtec.

### SCOPE

To perform the following tests: Design Qualification test. Please see test plan.

### APPLICABLE DOCUMENTS

Standards: EIA Publication 364

### TEST SAMPLES AND PREPARATION

- 1) All materials were manufactured in accordance with the applicable product specification.
- 2) All test samples were identified and encoded to maintain traceability throughout the test sequences.
- 3) After soldering, the parts to be used for LLCR and DWV/IR testing were cleaned according to TLWI-0001.
- 4) Either an automated cleaning procedure or an ultrasonic cleaning procedure may be used.
- 5) The automated procedure is used with aqueous compatible soldering materials.
- 6) Parts not intended for testing LLCR and DWV/IR are visually inspected and cleaned if necessary.
- 7) Any additional preparation will be noted in the individual test sequences.

## FLOWCHARTS

### Gas Tight

#### Group 1

UMPE-04-T-16-06.0

UMPI-04-T-16-06.0

8 Assemblies

Step	Description
1.	LLCR (2)
2.	Gas Tight (1)
3.	LLCR (2) Max Delta = 5 mOhm



(1) Gas Tight = EIA-364-36

(2) LLCR = EIA-364-23

Open Circuit Voltage = 20 mV Max

Test Current = 100 mA Max

### Thermal Aging

#### Group 1

UMPE-04-T-16-06.0

UMPI-04-T-16-06.0

8 Assemblies

Step	Description
1.	Contact Gaps
2.	Mating/Unmating Force (2)
3.	LLCR (1)
4.	Thermal Age (3)
5.	LLCR (1) Max Delta = 5 mOhm
6.	Mating/Unmating Force (2)
7.	Contact Gaps



(1) LLCR = EIA-364-23

Open Circuit Voltage = 20 mV Max

Test Current = 100 mA Max

(2) Mating/Unmating Force = EIA-364-13

(3) Thermal Age = EIA-364-17

Test Condition = 4 (105°C)

Time Condition = B (250 Hours)

**FLOWCHARTS Continued****Mating/Unmating/Durability**

*Note: do not damage the metal latch and keep the latches disengaged while taking force.*

<u>Group 1</u>		<u>Group 2</u>		<u>Group 3</u>	
UMPE-04-T-16-06.0		UMPE-02-T-16-04.0-S-M1		UMPE-10-T-16-05.0-S-M1	
UMPI-04-T-16-06.0		UMPI-02-T-16-04.0-M1		UMPI-10-T-16-05.0-M1	
8 Assemblies		8 Assemblies		8 Assemblies	
Middle Position		Smallest Position		Largest Position	
Step	Description	Step	Description	Step	Description
1.	Contact Gaps	1.	Contact Gaps	1.	Contact Gaps
2.	LLCR <sup>(2)</sup>	2.	Mating/Unmating Force <sup>(3)</sup>	2.	Mating/Unmating Force <sup>(3)</sup>
3.	Mating/Unmating Force <sup>(3)</sup>	3.	Cycles	3.	Cycles
4.	Cycles	4.	Quantity = 25 Cycles	4.	Quantity = 25 Cycles
5.	Mating/Unmating Force <sup>(3)</sup>	4.	Mating/Unmating Force <sup>(3)</sup>	4.	Mating/Unmating Force <sup>(3)</sup>
6.	Cycles	5.	Cycles	5.	Cycles
7.	Quantity = 25 Cycles	6.	Quantity = 25 Cycles	6.	Quantity = 25 Cycles
8.	Mating/Unmating Force <sup>(3)</sup>	6.	Mating/Unmating Force <sup>(3)</sup>	6.	Mating/Unmating Force <sup>(3)</sup>
9.	Cycles	7.	Cycles	7.	Cycles
10.	Quantity = 25 Cycles	7.	Quantity = 25 Cycles	7.	Quantity = 25 Cycles
11.	Mating/Unmating Force <sup>(3)</sup>	8.	Mating/Unmating Force <sup>(3)</sup>	8.	Mating/Unmating Force <sup>(3)</sup>
12.	Cycles	9.	Cycles	9.	Cycles
13.	Quantity = 25 Cycles	9.	Quantity = 25 Cycles	9.	Quantity = 25 Cycles
14.	Mating/Unmating Force <sup>(3)</sup>	10.	Mating/Unmating Force <sup>(3)</sup>	10.	Mating/Unmating Force <sup>(3)</sup>
15.	Contact Gaps	11.	Contact Gaps	11.	Contact Gaps
16.	LLCR <sup>(2)</sup>				
17.	Max Delta = 5 mOhm				
18.	Thermal Shock <sup>(4)</sup>				
19.	LLCR <sup>(2)</sup>				
20.	Max Delta = 5 mOhm				
21.	Humidity <sup>(1)</sup>				
22.	LLCR <sup>(2)</sup>				
23.	Max Delta = 5 mOhm				
24.	Mating/Unmating Force <sup>(3)</sup>				

(1) Humidity = EIA-364-31

Test Condition = B (240 Hours)

Test Method = III (+25°C to +65°C @ 90% RH to 98% RH)

Test Exceptions: ambient pre-condition and delete steps 7a and 7b

(2) LLCR = EIA-364-23

Open Circuit Voltage = 20 mV Max

Test Current = 100 mA Max

(3) Mating/Unmating Force = EIA-364-13

(4) Thermal Shock = EIA-364-32

Exposure Time at Temperature Extremes = 1/2 Hour

Method A, Test Condition = I (-55°C to +85°C)

Test Duration = A-3 (100 Cycles)

**FLOWCHARTS Continued****IR/DWV****Pin-to-Pin**

<u>Group 1</u>		<u>Group 2</u>		<u>Group 3</u>		<u>Group 4</u>	
UMPE-04-T-16-06.0		UMPI-04-T-16-06.0		UMPE-04-T-16-06.0		UMPE-04-T-16-06.0	
2 Assemblies		2 Assemblies		2 Assemblies		2 Assemblies	
Cable Breakdown		Connector Breakdown		Mated Set Breakdown		Mated Set With Conditions Test	
Step	Description	Step	Description	Step	Description	Step	Description
1.	DWV Breakdown (2)	1.	DWV Breakdown (2)	1.	DWV Breakdown (2)	1.	IR (4)
						2.	DWV at Test Voltage (1)
						3.	Thermal Shock (5)
						4.	IR (4)
						5.	DWV at Test Voltage (1)
						6.	Humidity (3)
						7.	IR (4)
						8.	DWV at Test Voltage (1)

(1) DWV at Test Voltage = EIA-364-20

Test Condition = 1 (Sea Level)

DWV test voltage is equal to 75% of the lowest breakdown voltage

Test voltage applied for 60 seconds

(2) DWV Breakdown = EIA-364-20

Test Condition = 1 (Sea Level)

DWV test voltage is equal to 75% of the lowest breakdown voltage

Test voltage applied for 60 seconds

(3) Humidity = EIA-364-31

Test Condition = B (240 Hours)

Test Method = III (+25°C to +65°C @ 90% RH to 98% RH)

Test Exceptions: ambient pre-condition and delete steps 7a and 7b

(4) IR = EIA-364-21

Test Condition = 500 Vdc, 2 Minutes Max

(5) Thermal Shock = EIA-364-32

Exposure Time at Temperature Extremes = 1/2 Hour

Method A, Test Condition = I (-55°C to +85°C)

Test Duration = A-3 (100 Cycles)

**FLOWCHARTS Continued****Current Carrying Capacity**

<p style="text-align: center;"><u>Group 1</u></p> <p style="text-align: center;">UMPE-10-T-16-12.0 UMPI-10-T-16-12.0 1 Pins Powered Signal</p> <hr/> <p><b>Step Description</b></p> <p>1. CCC <sup>(1)</sup> Rows = 1 Number of Positions = 1</p>	<p style="text-align: center;"><u>Group 2</u></p> <p style="text-align: center;">UMPE-10-T-16-12.0 UMPI-10-T-16-12.0 2 Pins Powered Signal</p> <hr/> <p><b>Step Description</b></p> <p>1. CCC <sup>(1)</sup> Rows = 1 Number of Positions = 2</p>	<p style="text-align: center;"><u>Group 3</u></p> <p style="text-align: center;">UMPE-10-T-16-12.0 UMPI-10-T-16-12.0 3 Pins Powered Signal</p> <hr/> <p><b>Step Description</b></p> <p>1. CCC <sup>(1)</sup> Rows = 1 Number of Positions = 3</p>	<p style="text-align: center;"><u>Group 4</u></p> <p style="text-align: center;">UMPE-10-T-16-12.0 UMPI-10-T-16-12.0 4 Pins Powered Signal</p> <hr/> <p><b>Step Description</b></p> <p>1. CCC <sup>(1)</sup> Rows = 1 Number of Positions = 4</p>
<p style="text-align: center;"><u>Group 5</u></p> <p style="text-align: center;">UMPE-10-T-16-12.0 UMPI-10-T-16-12.0 10 Pins Powered Signal</p> <hr/> <p><b>Step Description</b></p> <p>1. CCC <sup>(1)</sup> Rows = 1 Number of Positions = 10</p>	<p style="text-align: center;"><u>Group 6</u></p> <p style="text-align: center;">UMPE-10-T-18-12.0 UMPI-10-T-18-12.0 1 Pins Powered Signal</p> <hr/> <p><b>Step Description</b></p> <p>1. CCC <sup>(1)</sup> Rows = 1 Number of Positions = 1</p>	<p style="text-align: center;"><u>Group 7</u></p> <p style="text-align: center;">UMPE-10-T-18-12.0 UMPI-10-T-18-12.0 2 Pins Powered Signal</p> <hr/> <p><b>Step Description</b></p> <p>1. CCC <sup>(1)</sup> Rows = 1 Number of Positions = 2</p>	<p style="text-align: center;"><u>Group 8</u></p> <p style="text-align: center;">UMPE-10-T-18-12.0 UMPI-10-T-18-12.0 3 Pins Powered Signal</p> <hr/> <p><b>Step Description</b></p> <p>1. CCC <sup>(1)</sup> Rows = 1 Number of Positions = 3</p>
<p style="text-align: center;"><u>Group 9</u></p> <p style="text-align: center;">UMPE-10-T-18-12.0 UMPI-10-T-18-12.0 4 Pins Powered Signal</p> <hr/> <p><b>Step Description</b></p> <p>1. CCC <sup>(1)</sup> Rows = 1 Number of Positions = 4</p>	<p style="text-align: center;"><u>Group 10</u></p> <p style="text-align: center;">UMPE-10-T-18-12.0 UMPI-10-T-18-12.0 10 Pins Powered Signal</p> <hr/> <p><b>Step Description</b></p> <p>1. CCC <sup>(1)</sup> Rows = 1 Number of Positions = 10</p>	<p style="text-align: center;"><u>Group 11</u></p> <p style="text-align: center;">UMPE-10-S-16-12.0 UMPI-10-S-16-12.0 1 Pins Powered Signal</p> <hr/> <p><b>Step Description</b></p> <p>1. CCC <sup>(1)</sup> Rows = 1 Number of Positions = 1</p>	<p style="text-align: center;"><u>Group 12</u></p> <p style="text-align: center;">UMPE-10-S-16-12.0 UMPI-10-S-16-12.0 2 Pins Powered Signal</p> <hr/> <p><b>Step Description</b></p> <p>1. CCC <sup>(1)</sup> Rows = 1 Number of Positions = 2</p>
<p style="text-align: center;"><u>Group 13</u></p> <p style="text-align: center;">UMPE-10-S-16-12.0 UMPI-10-S-16-12.0 3 Pins Powered Signal</p> <hr/> <p><b>Step Description</b></p> <p>1. CCC <sup>(1)</sup> Rows = 1 Number of Positions = 3</p>	<p style="text-align: center;"><u>Group 14</u></p> <p style="text-align: center;">UMPE-10-S-16-12.0 UMPI-10-S-16-12.0 4 Pins Powered Signal</p> <hr/> <p><b>Step Description</b></p> <p>1. CCC <sup>(1)</sup> Rows = 1 Number of Positions = 4</p>	<p style="text-align: center;"><u>Group 15</u></p> <p style="text-align: center;">UMPE-10-S-16-12.0 UMPI-10-S-16-12.0 10 Pins Powered Signal</p> <hr/> <p><b>Step Description</b></p> <p>1. CCC <sup>(1)</sup> Rows = 1 Number of Positions = 10</p>	

(1) CCC = EIA-364-70

Method 2, Temperature Rise Versus Current Curve

(TIN PLATING) - Tabulate calculated current at RT, 65°C, 75°C and 95°C after derating 20% and based on 105°C

(GOLD PLATING) - Tabulate calculated current at RT, 85°C, 95°C and 115°C after derating 20% and based on 125°C

**FLOWCHARTS Continued****Mechanical Shock/Random Vibration/LLCR**Group 1

UMPE-04-T-16-16.0

UMPI-04-T-16-16.0

8 Assemblies

Metal Latch

**Step Description**

1. LLCR <sup>(1)</sup>
2. Mechanical Shock <sup>(2)</sup>
3. Random Vibration <sup>(3)</sup>
4. LLCR <sup>(1)</sup>  
Max Delta = 5 mOhm

**(1) LLCR = EIA-364-23**

Open Circuit Voltage = 20 mV Max

Test Current = 100 mA Max

**(2) Mechanical Shock = EIA-364-27**

Test Condition = C (100 G Peak, 6 milliseconds, Half Sine)

Number of Shocks = 3 Per Direction, Per Axis, 18 Total

**(3) Random Vibration = EIA-364-28**

Condition = VB (7.56 gRMS Average, 2 Hours/Axis)

**Mechanical Shock/Random Vibration/Event Detection**Group 1

UMPE-04-T-16-16.0

UMPI-04-T-16-16.0

60 Points

Metal Latch

**Step Description**

1. Nanosecond Event Detection  
(Mechanical Shock) <sup>(1)</sup>
2. Nanosecond Event Detection  
(Random Vibration) <sup>(2)</sup>

**(1) Nanosecond Event Detection (Mechanical Shock)**

Use EIA-364-87 for Nanosecond Event Detection:

Test Condition = F (50 nanoseconds at 10 ohms)

Use EIA-364-27 for Mechanical Shock:

Test Condition = C (100 G Peak, 6 milliseconds, Half Sine)

Number of Shocks = 3 Per Direction, Per Axis, 18 Total

**(2) Nanosecond Event Detection (Random Vibration)**

Use EIA-364-87 for Nanosecond Event Detection:

Test Condition = F (50 nanoseconds at 10 ohms)

Use EIA-364-28 for Random Vibration:

Condition = VB (7.56 gRMS Average, 2 Hours/Axis)

**FLOWCHARTS Continued****Cable Pull**

*Note: Pull until electrical or mechanical failure.*

Group 1

UMPE-04-T-16-06.0

UMPI-04-T-16-06.0

5 Assemblies

0 Degrees Metal Latch

Group 2

UMPE-04-T-16-06.0

UMPI-04-T-16-06.0

5 Assemblies

90 Degrees Metal Latch

**Step Description**

1. Cable Pull (1)

**Step Description**

1. Cable Pull (1)

---

(1) Cable Pull = EIA-364-38

Measure and Record Force Required to Failure

Failure = Discontinuity &gt;1 microsecond at 10 ohms

**Cable Flex**

*Note: Use testing voltage found during IR/DWV testing in this test plan.*

Group 1

UMPE-04-T-16-16.0

UMPI-04-T-16-16.0

8 Assemblies

Metal Latch

*Note: 16 oz of hanging weight.*

**Step Description**

1. IR (3)
2. DWV at Test Voltage (2)
3. Cable Flex (1)
4. Visual Inspection
5. IR (3)
6. DWV at Test Voltage (2)
7. Rotate Cable 90°
8. Cable Flex (1)
9. Visual Inspection
10. IR (3)
11. DWV at Test Voltage (2)

---

(1) Cable Flex = EIA-364-41

Circular Jacket Cable - to be tested 90° each direction (180° total)

Flat Cable - to be tested 70° each direction (140° total)

Monitor continuity during flex testing

Failure = Discontinuity &gt;1 microsecond at 10 ohms

(2) DWV at Test Voltage = EIA-364-20

Test Condition = 1 (Sea Level)

DWV test voltage is equal to 75% of the lowest breakdown voltage

Test voltage applied for 60 seconds

(3) IR = EIA-364-21

Test Condition = 500 Vdc, 2 Minutes Max

**FLOWCHARTS Continued****Latch Cycling**Group 1

UMPE-04-T-16-06.0

UMPI-04-T-16-06.0

8 Assemblies

Metal Latch

**Step Description**

1. Photos (2)  
*Note: Mate the connectors. No force measurement is needed here. Take a photo of the latch being engaged. Manually pull on the the connectors to make sure the latch is engaged. Then unmate and proceed to cycling.*
2. Cycles  
Quantity = 100 Cycles  
*Note: Manually cycle parts allowing latches to engage on each cycle.*
3. Photos (2)  
*Note: Mate the connectors. No force measurement is needed here. Take a photo of the latch being engaged. Manually pull on the the connectors to make sure the latch is engaged.*
4. Mating/Unmating Force (1)  
*Note: Hook up to the Starrett press and pull the latch to failure. Record the 0° pull force to failure.*

---

(1) Mating/Unmating Force = EIA-364-13

(2) Photos

Attach 2-3 photos of contact area

## ATTRIBUTE DEFINITIONS

The following is a brief, simplified description of attributes.

### THERMAL SHOCK:

- 1) EIA-364-32, *Thermal Shock (Temperature Cycling) Test Procedure for Electrical Connectors*.
- 2) Test Condition 1: -55°C to +85°C
- 3) Test Time: ½ hour dwell at each temperature extreme
- 4) Number of Cycles: 100
- 5) All test samples are pre-conditioned at ambient.
- 6) All test samples are exposed to environmental stressing in the mated condition.

### THERMAL:

- 1) EIA-364-17, *Temperature Life with or without Electrical Load Test Procedure for Electrical Connectors*.
- 2) Test Condition 4 at 105° C
- 3) Test Time Condition B for 250 hours.
- 4) All test samples are pre-conditioned at ambient.
- 5) All test samples are exposed to environmental stressing in the mated condition.

### HUMIDITY:

- 1) Reference document: EIA-364-31, *Humidity Test Procedure for Electrical Connectors*.
- 2) Test Condition B, 240 Hours.
- 3) Method III, +25° C to + 65° C, 90% to 98% Relative Humidity excluding sub-cycles 7a and 7b.
- 4) All samples are pre-conditioned at ambient.
- 5) All test samples are exposed to environmental stressing in the mated condition.

### MECHANICAL SHOCK (Specified Pulse):

- 1) Reference document: EIA-364-27, *Mechanical Shock Test Procedure for Electrical Connectors*
- 2) Test Condition C
- 3) Peak Value: 100 G
- 4) Duration: 6 Milliseconds
- 5) Wave Form: Half Sine
- 6) Velocity: 12.3 ft/s
- 7) Number of Shocks: 3 Shocks / Direction, 3 Axis (18 Total)

### VIBRATION:

- 1) Reference document: EIA-364-28, *Vibration Test Procedure for Electrical Connectors*
- 2) Test Condition V, Letter B
- 3) Power Spectral Density: 0.04 G<sup>2</sup> / Hz
- 4) G 'RMS': 7.56
- 5) Frequency: 50 to 2000 Hz
- 6) Duration: 2.0 Hours per axis (3 axis total)

### NANOSECOND-EVENT DETECTION:

- 1) Reference document: EIA-364-87, *Nanosecond-Event Detection for Electrical Connectors*
- 2) Prior to test, the samples were characterized to assure the low nanosecond event being monitored will trigger the detector.
- 3) After characterization it was determined the test samples could be monitored for 50 nanosecond events

### MATING/UNMATING:

- 1) Reference document: EIA-364-13, *Mating and Unmating Forces Test Procedure for Electrical Connectors*.
- 2) The full insertion position was to within 0.003” to 0.004” of the plug bottoming out in the receptacle to prevent damage to the system under test.
- 3) One of the mating parts is secured to a floating X-Y table to prevent damage during cycling.

### ATTRIBUTE DEFINITIONS Continued

The following is a brief, simplified description of attributes.

#### TEMPERATURE RISE (Current Carrying Capacity, CCC):

- 1) EIA-364-70, *Temperature Rise versus Current Test Procedure for Electrical Connectors and Sockets*.
- 2) When current passes through a contact, the temperature of the contact increases as a result of  $I^2R$  (resistive) heating.
- 3) The number of contacts being investigated plays a significant part in power dissipation and therefore temperature rise.
- 4) The size of the temperature probe can affect the measured temperature.
- 5) Copper traces on PC boards will contribute to temperature rise:
  - a. Self-heating (resistive)
  - b. Reduction in heat sink capacity affecting the heated contacts
- 6) A de-rating curve, usually 20%, is calculated.
- 7) Calculated de-rated currents at four temperature points are reported:
  - a. Ambient
  - b. 65° C
  - c. 75° C
  - d. 95° C
- 8) Typically, neighboring contacts (in close proximity to maximize heat buildup) are energized.
- 9) The thermocouple (or temperature measuring probe) will be positioned at a location to sense the maximum temperature in the vicinity of the heat generation area.
- 10) A computer program, *TR 803.exe*, ensures accurate stability for data acquisition.
- 11) Hook-up wire cross section is larger than the cross section of any connector leads/PC board traces, jumpers, etc.
- 12) Hook-up wire length is longer than the minimum specified in the referencing standard.

**ATTRIBUTE DEFINITIONS Continued**

The following is a brief, simplified description of attributes.

**LLCR:**

- 1) EIA-364-23, *Low Level Contact Resistance Test Procedure for Electrical Connectors and Sockets*.
- 2) A computer program, *LLCR 221.exe*, ensures repeatability for data acquisition.
- 3) The following guidelines are used to categorize the changes in LLCR as a result from stressing.
  - a.  $\leq +1.0$  mOhms: -----Stable
  - b.  $+1.1$  to  $+2.0$  mOhms: -----Minor
  - c.  $+2.1$  to  $+5.0$  mOhms: -----Acceptable
  - d.  $+5.1$  to  $+15.0$  mOhms:-----Marginal
  - e.  $+15.1$  to  $+1000$  mOhms: -----Unstable
  - f.  $>+1000$  mOhms:-----Open Failure

**GAS TIGHT:**

To provide method for evaluating the ability of the contacting surfaces in preventing penetration of harsh vapors which might lead to oxide formation that may degrade the electrical performance of the contact system.

- 1) EIA-364-23, *Low Level Contact Resistance Test Procedure for Electrical Connectors and Sockets*.
- 2) A computer program, *LLCR 221.exe*, ensures repeatability for data acquisition.
- 3) The following guidelines are used to categorize the changes in LLCR as a result from stressing.
  - a.  $\leq +1.0$  mOhms:-----Stable
  - b.  $+1.1$  to  $+2.0$  mOhms: -----Minor
  - c.  $+2.1$  to  $+5.0$  mOhms: -----Acceptable
  - d.  $+5.1$  to  $+15.0$  mOhms: -----Marginal
  - e.  $+15.1$  to  $+1000$  mOhms:-----Unstable
  - f.  $>+1000$  mOhms:-----Open Failure
- 4) Procedure:
  - a. Reference document: EIA-364-36, *Test Procedure for Determination of Gas-Tight Characteristics for Electrical Connectors, Sockets and/or Contact Systems*.
  - b. Test Conditions:
    - i. Class II--- Mated pairs of contacts assembled to their plastic housings.
    - ii. Reagent grade Nitric Acid shall be used of sufficient volume to saturate the test chamber
    - iii. The ratio of the volume of the test chamber to the surface area of the acid shall be 10:1.
    - iv. The chamber shall be saturated with the vapor for at least 15 minutes before samples are added.
    - v. Exposure time, 55 to 65 minutes.
    - vi. The samples shall be no closer to the chamber walls than 1 inches and no closer to the surface of the acid than 3 inches.
    - vii. The samples shall be dried after exposure for a minimum of 1 hour.
    - viii. Drying temperature  $50^{\circ}$  C
    - ix. The final LLCR shall be conducted within 1 hour after drying.

### **ATTRIBUTE DEFINITIONS Continued**

The following is a brief, simplified description of attributes.

#### **INSULATION RESISTANCE (IR):**

To determine the resistance of insulation materials to leakage of current through or on the surface of these materials when a DC potential is applied.

- 1) PROCEDURE:
  - a. Reference document: EIA-364-21, *Insulation Resistance Test Procedure for Electrical Connectors*.
  - b. Test Conditions:
    - i. Between Adjacent Contacts or Signal-to-Ground
    - ii. Electrification Time 2.0 minutes
    - iii. Test Voltage (500 VDC) corresponds to calibration settings for measuring resistances.
- 2) MEASUREMENTS:
- 3) When the specified test voltage is applied (VDC), the insulation resistance shall not be less than 1000 megohms.

#### **DIELECTRIC WITHSTANDING VOLTAGE (DWV):**

To determine if the sockets can operate at its rated voltage and withstand momentary over potentials due to switching, surges, and other similar phenomenon. Separate samples are used to evaluate the effect of environmental stresses so not to influence the readings from arcing that occurs during the measurement process.

- 1) PROCEDURE:
  - a. Reference document: EIA-364-20, *Withstanding Voltage Test Procedure for Electrical Connectors*.
  - b. Test Conditions:
    - i. Between Adjacent Contacts or Signal-to-Ground
    - ii. Barometric Test Condition 1
    - iii. Rate of Application 500 V/Sec
    - iv. Test Voltage (VAC) until breakdown occurs
- 2) MEASUREMENTS/CALCULATIONS
  - a. The breakdown voltage shall be measured and recorded.
  - b. The dielectric withstanding voltage shall be recorded as 75% of the minimum breakdown voltage.
  - c. The working voltage shall be recorded as one-third (1/3) of the dielectric withstanding voltage (one-fourth of the breakdown voltage).

### ATTRIBUTE DEFINITIONS Continued

The following is a brief, simplified description of attributes.

#### CABLE PULL:

- 1) Secure cable near center and pull on connector
  - a. At  $90^\circ$ , right angle to cable
  - b. At  $0^\circ$ , in-line with cable

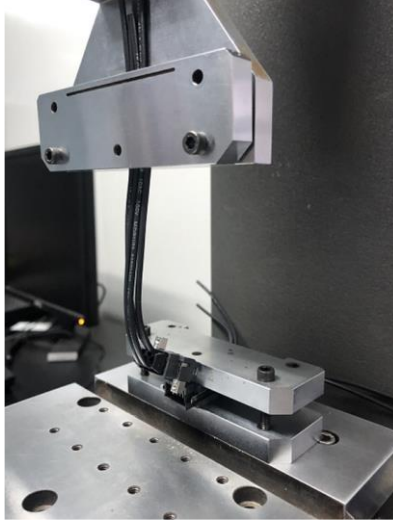

Fig. 1  
90° Connector pull

#### CABLE DURABILITY:

- 1) Oscillate and monitor electrical continuity for open circuit indication.
  - a.  $\pm 90^\circ$  Flex Mode, bend up to 500 cycles. load on cable end.



Fig. 2  
(Setup picture)

## RESULTS

### Temperature Rise, CCC at a 20% de-rating

#### UMPE-10-T-16-12.0/UMPI-10-T-16-12.0

- CCC for a 30°C Temperature Rise-----18.5 A per contact with 1 contact (1x1) powered.
- CCC for a 30°C Temperature Rise-----17.0 A per contact with 2 contacts (1x2) powered.
- CCC for a 30°C Temperature Rise-----13.7 A per contact with 3 contacts (1x3) powered.
- CCC for a 30°C Temperature Rise-----12.2 A per contact with 4 contacts (1x4) powered.
- CCC for a 30°C Temperature Rise-----8.5 A per contact with 10 contacts (1x10) powered.

#### UMPE-10-T-18-12.0/UMPI-10-T-18-12.0

- CCC for a 30°C Temperature Rise-----17.5 A per contact with 1 contact (1x1) powered.
- CCC for a 30°C Temperature Rise-----12.7 A per contact with 2 contacts (1x2) powered.
- CCC for a 30°C Temperature Rise-----10.5 A per contact with 3 contacts (1x3) powered.
- CCC for a 30°C Temperature Rise-----9.4 A per contact with 4 contacts (1x4) powered.
- CCC for a 30°C Temperature Rise-----6.7 A per contact with 10 contacts (1x10) powered.

#### UMPE-10-S-16-12.0/UMPI-10-S-16-12.0

- CCC for a 30°C Temperature Rise-----22.5 A per contact with 1 contact (1x1) powered.
- CCC for a 30°C Temperature Rise-----15.8 A per contact with 2 contacts (1x2) powered.
- CCC for a 30°C Temperature Rise-----13.6 A per contact with 3 contacts (1x3) powered.
- CCC for a 30°C Temperature Rise-----11.9 A per contact with 4 contacts (1x4) powered.
- CCC for a 30°C Temperature Rise-----8.8 A per contact with 10 contacts (1x10) powered.

### Mating – Unmating Forces

#### Thermal Aging Group

- **Initial**
  - **Mating**
    - Min ----- 3.96 Lbs
    - Max----- 4.40 Lbs
  - **Unmating**
    - Min ----- 2.69 Lbs
    - Max----- 3.86 Lbs
- **After Thermal**
  - **Mating**
    - Min ----- 2.33 Lbs
    - Max----- 3.24 Lbs
  - **Unmating**
    - Min ----- 2.00 Lbs
    - Max----- 3.27 Lbs

**RESULTS Continued****Mating – Unmating Forces****Mating-Unmating Durability**

- **Initial**
  - **Mating**
    - **Min** ----- 3.58 Lbs
    - **Max** ----- 4.38 Lbs
  - **Unmating**
    - **Min** ----- 2.40 Lbs
    - **Max** ----- 3.94 Lbs
- **After 25 Cycles**
  - **Mating**
    - **Min** ----- 4.50 Lbs
    - **Max** ----- 5.78 Lbs
  - **Unmating**
    - **Min** ----- 4.03 Lbs
    - **Max** ----- 4.83 Lbs
- **After 50 Cycles**
  - **Mating**
    - **Min** ----- 5.14 Lbs
    - **Max** ----- 6.43 Lbs
  - **Unmating**
    - **Min** ----- 3.84 Lbs
    - **Max** ----- 5.49 Lbs
- **After 75 Cycles**
  - **Mating**
    - **Min** ----- 4.13 Lbs
    - **Max** ----- 5.73 Lbs
  - **Unmating**
    - **Min** ----- 3.47 Lbs
    - **Max** ----- 5.24 Lbs
- **After 100 Cycles**
  - **Mating**
    - **Min** ----- 4.32 Lbs
    - **Max** ----- 5.59 Lbs
  - **Unmating**
    - **Min** ----- 3.48 Lbs
    - **Max** ----- 5.07 Lbs
- **Humidity**
  - **Mating**
    - **Min** ----- 2.58 Lbs
    - **Max** ----- 3.02 Lbs
  - **Unmating**
    - **Min** ----- 2.17 Lbs
    - **Max** ----- 2.58 Lbs

**RESULTS Continued****Mating-Unmating Basic (UMPE-02-T-16-04.0-S-M1\UMPI-02-T-16-04.0-M1)**

- **Initial**
  - **Mating**
    - **Min** ----- 1.44 Lbs
    - **Max** ----- 2.65 Lbs
  - **Unmating**
    - **Min** ----- 1.06 Lbs
    - **Max** ----- 1.87 Lbs
- **After 25 Cycles**
  - **Mating**
    - **Min** ----- 2.05 Lbs
    - **Max** ----- 3.03 Lbs
  - **Unmating**
    - **Min** ----- 2.11 Lbs
    - **Max** ----- 2.53 Lbs
- **After 50 Cycles**
  - **Mating**
    - **Min** ----- 2.55 Lbs
    - **Max** ----- 3.48 Lbs
  - **Unmating**
    - **Min** ----- 2.21 Lbs
    - **Max** ----- 2.60 Lbs
- **After 75 Cycles**
  - **Mating**
    - **Min** ----- 2.29 Lbs
    - **Max** ----- 2.70 Lbs
  - **Unmating**
    - **Min** ----- 1.86 Lbs
    - **Max** ----- 2.16 Lbs
- **After 100 Cycles**
  - **Mating**
    - **Min** ----- 2.20 Lbs
    - **Max** ----- 2.64 Lbs
  - **Unmating**
    - **Min** ----- 1.85 Lbs
    - **Max** ----- 2.06 Lbs

**RESULTS Continued****Mating-Unmating Basic (UMPE-10-T-16-05.0-S-M1\UMPI-10-T-16-05.0-M1)**

- **Initial**
  - **Mating**
    - **Min** -----10.60 Lbs
    - **Max** -----12.37 Lbs
  - **Unmating**
    - **Min** ----- 6.49 Lbs
    - **Max** ----- 8.62 Lbs
- **After 25 Cycles**
  - **Mating**
    - **Min** -----11.18 Lbs
    - **Max** -----13.67 Lbs
  - **Unmating**
    - **Min** -----10.29 Lbs
    - **Max** -----10.98 Lbs
- **After 50 Cycles**
  - **Mating**
    - **Min** -----12.30 Lbs
    - **Max** -----15.46 Lbs
  - **Unmating**
    - **Min** -----10.01 Lbs
    - **Max** -----11.93 Lbs
- **After 75 Cycles**
  - **Mating**
    - **Min** -----11.72 Lbs
    - **Max** -----14.27 Lbs
  - **Unmating**
    - **Min** ----- 9.27 Lbs
    - **Max** -----10.63 Lbs
- **After 100 Cycles**
  - **Mating**
    - **Min** -----10.89 Lbs
    - **Max** -----13.55 Lbs
  - **Unmating**
    - **Min** ----- 8.92 Lbs
    - **Max** -----10.93 Lbs

**Cable Pull force**

- **0° Pull**
  - **Min** -----13.66 lbs
  - **Max** -----17.72 lbs
- **90° Pull**
  - **Min** -----12.29 lbs
  - **Max** -----13.58 lbs

**Latch Pull Force**

- **Min** -----15.74 Lbs
- **Max** -----21.42 Lbs

**RESULTS Continued****Insulation Resistance minimums, IR****Pin to Pin**

- **Initial**
  - Mated-----45000 Meg  $\Omega$  ----- Passed
  - Unmated -----45000 Meg  $\Omega$  ----- Passed
- **Thermal Shock**
  - Mated-----45000 Meg  $\Omega$  ----- Passed
  - Unmated -----45000Meg  $\Omega$  ----- Passed
- **Humidity**
  - Mated-----12500 Meg  $\Omega$  ----- Passed
  - Unmated -----34000 Meg  $\Omega$  ----- Passed

**Dielectric Withstanding Voltage minimums, DWV**

- **Minimums**
  - Breakdown Voltage----- 1776 VAC
  - Test Voltage ----- 1335 VAC
  - Working Voltage -----445 VAC

**Pin to Pin**

- **Initial DWV** -----Passed
- **Thermal DWV**-----Passed
- **Humidity DWV**-----Passed

**Cable Flex:****Insulation Resistance minimums, IR****Pin to Pin**

- **Initial**
  - Mated-----45000 Meg  $\Omega$  ----- Passed
- **After 500 flex cycles**
  - Mated-----45000 Meg  $\Omega$  ----- Passed

**Dielectric Withstanding Voltage minimums, DWV**

- Test Voltage ----- 1335 VAC

**Pin to Pin**

- **Initial DWV** -----Passed
- **After 500 Flex cycles DWV** -----Passed

**RESULTS Continued****LLCR Gas Tight Group (32 LLCR test points)**

- **Initial** -----4.78 mOhms Max
- **Gas Tight**
  - <= +1.0 mOhms----- 32 Points ----- Stable
  - +1.1 to +2.0 mOhms ----- 0 Points ----- Minor
  - +2.1 to +5.0 mOhms ----- 0 Points ----- Acceptable
  - +5.1 to +15.0 mOhms ----- 0 Points ----- Marginal
  - +15.1 to +1000 mOhms----- 0 Points ----- Unstable
  - >+1000 mOhms----- 0 Points ----- Open Failure

**LLCR Thermal Aging Group (32 LLCR test points)**

- **Initial** -----4.71 mOhms Max
- **Thermal**
  - <= +1.0 mOhms----- 32 Points ----- Stable
  - +1.1 to +2.0 mOhms ----- 0 Points ----- Minor
  - +2.1 to +5.0 mOhms ----- 0 Points ----- Acceptable
  - +5.1 to +15.0 mOhms ----- 0 Points ----- Marginal
  - +15.1 to +1000 mOhms----- 0 Points ----- Unstable
  - >+1000 mOhms----- 0 Points ----- Open Failure

**LLCR Mating/Unmating Durability Group (32 LLCR test points)**

- **Initial** -----4.72 mOhms Max
- **Durability, 100 Cycles**
  - <= +1.0 mOhms----- 32 Points ----- Stable
  - +1.1 to +2.0 mOhms ----- 0 Points ----- Minor
  - +2.1 to +5.0 mOhms ----- 0 Points ----- Acceptable
  - +5.1 to +15.0 mOhms ----- 0 Points ----- Marginal
  - +15.1 to +1000 mOhms----- 0 Points ----- Unstable
  - >+1000 mOhms----- 0 Points ----- Open Failure
- **Thermal Shock**
  - <= +1.0 mOhms----- 30 Points ----- Stable
  - +1.1 to +2.0 mOhms ----- 2 Points ----- Minor
  - +2.1 to +5.0 mOhms ----- 0 Points ----- Acceptable
  - +5.1 to +15.0 mOhms ----- 0 Points ----- Marginal
  - +15.1 to +1000 mOhms----- 0 Points ----- Unstable
  - >+1000 mOhms----- 0 Points ----- Open Failure
- **Humidity**
  - <= +1.0 mOhms----- 23 Points ----- Stable
  - +1.1 to +2.0 mOhms ----- 9 Points ----- Minor
  - +2.1 to +5.0 mOhms ----- 0 Points ----- Acceptable
  - +5.1 to +15.0 mOhms ----- 0 Points ----- Marginal
  - +15.1 to +1000 mOhms----- 0 Points ----- Unstable
  - >+1000 mOhms----- 0 Points ----- Open Failure

**RESULTS Continued****LLCR Shock & Vibration (32 LLCR test points)**

- **Initial** ----- **11.33 mOhms Max**
- **Shock & Vibration**
  - **<= +1.0 mOhms**----- **32 Points** ----- **Stable**
  - **+1.1 to +2.0 mOhms** ----- **0 Points** ----- **Minor**
  - **+2.1 to +5.0 mOhms** ----- **0 Points** ----- **Acceptable**
  - **+5.1 to +15.0 mOhms** ----- **0 Points** ----- **Marginal**
  - **+15.1 to +1000 mOhms**----- **0 Points** ----- **Unstable**
  - **>+1000 mOhms** ----- **0 Points** ----- **Open Failure**

**Mechanical Shock & Random Vibration:**

- **Shock**
  - **No Damage**----- **Pass**
  - **50 Nanoseconds** ----- **Pass**
- **Vibration**
  - **No Damage**----- **Pass**
  - **50 Nanoseconds** ----- **Pass**

### DATA SUMMARIES

#### TEMPERATURE RISE (Current Carrying Capacity, CCC):

- 1) High quality thermocouples whose temperature slopes track one another were used for temperature monitoring.
- 2) The thermocouples were placed at a location to sense the maximum temperature generated during testing.
- 3) Temperature readings recorded are those for which three successive readings, 15 minutes apart, differ less than 1° C (computer-controlled data acquisition).
- 4) Adjacent contacts were powered:

#### UMPE-10-T-16-12.0/UMPI-10-T-16-12.0

- a. Linear configuration with 1 adjacent conductors/contacts powered

3467354  
1(1X1) Contacts in Series(Contact Interface)  
Part Numbers:UMPE-10-T-16-12.0/UMPI-10-T-16-12.0

Current Rating per Contact (30 Deg. Rise, 20% Derated) = 18.5 Amps

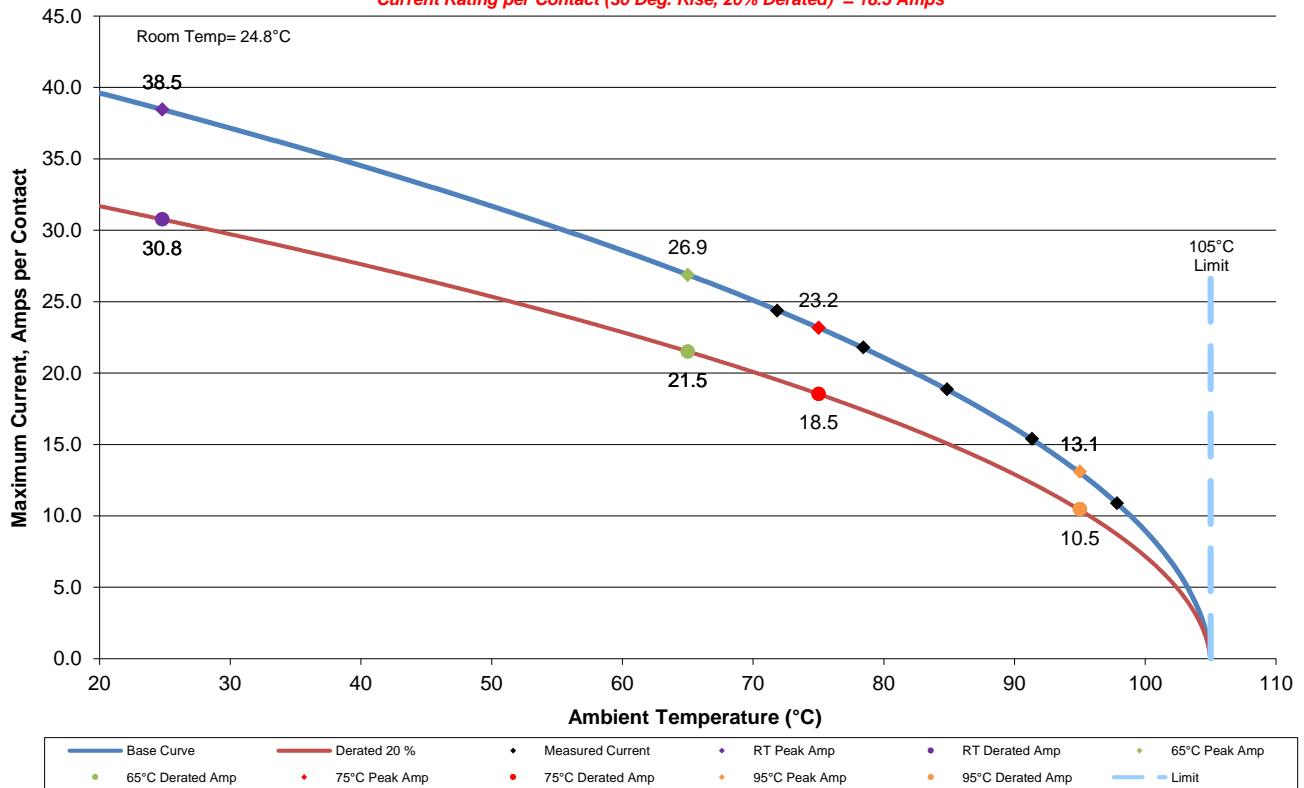

### DATA SUMMARIES Continued

3467354  
1(1X1) Contacts in Series(Contact Interface)  
Part Numbers:UMPE-10-T-16-12.0/UMPI-10-T-16-12.0

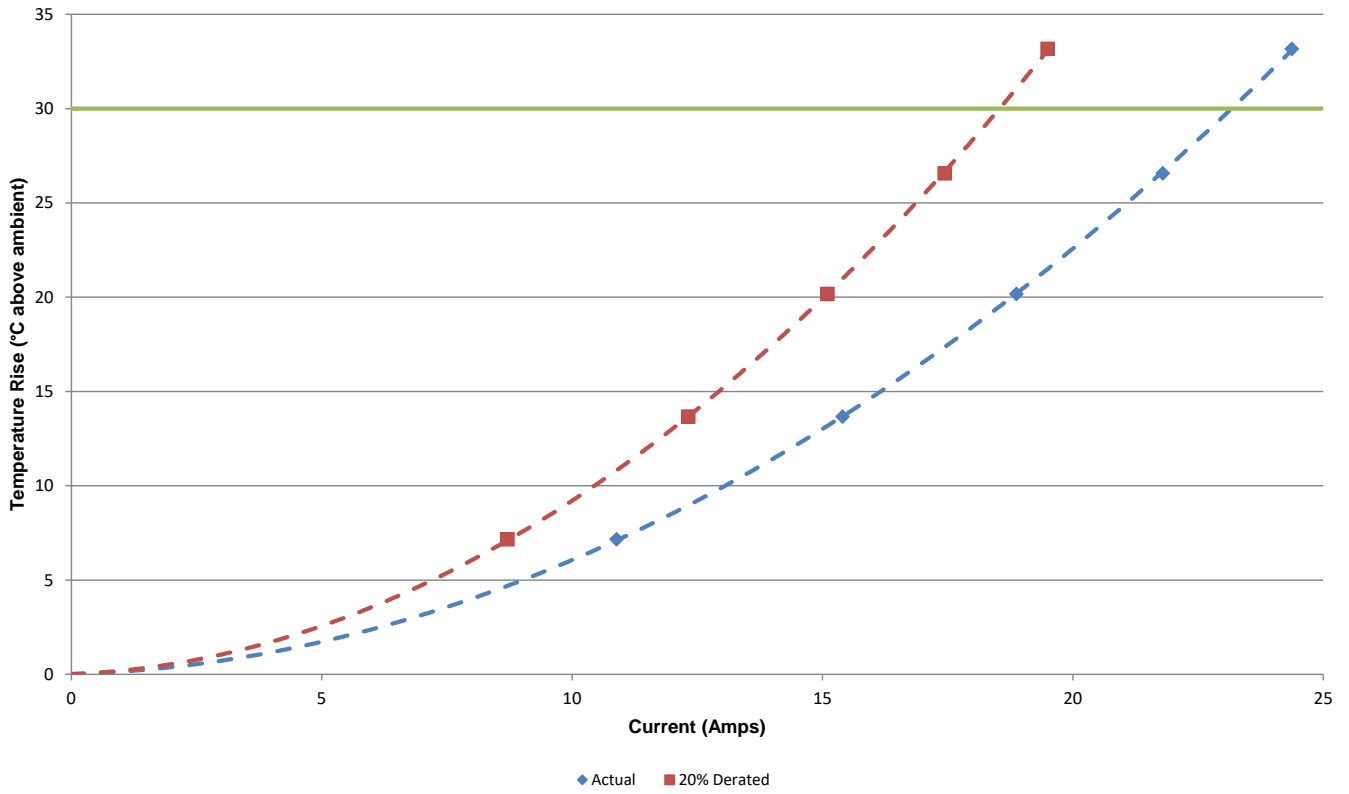

### DATA SUMMARIES Continued

b. Linear configuration with 2 adjacent conductors/contacts powered

3467354  
 2(1X2) Contacts in Series(Contact Interface)  
 Part Numbers:UMPE-10-T-16-12.0/UMPI-10-T-16-12.0

Current Rating per Contact (30 Deg. Rise, 20% Derated) = 17.0 Amps

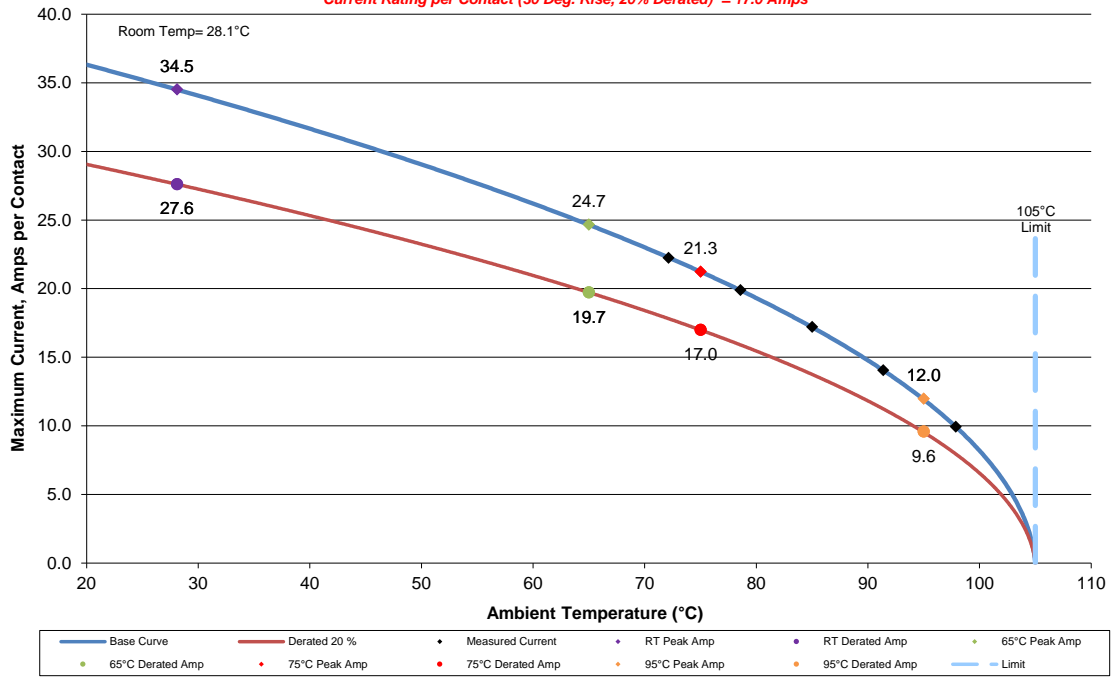

3467354  
 2(1X2) Contacts in Series(Contact Interface)  
 Part Numbers:UMPE-10-T-16-12.0/UMPI-10-T-16-12.0

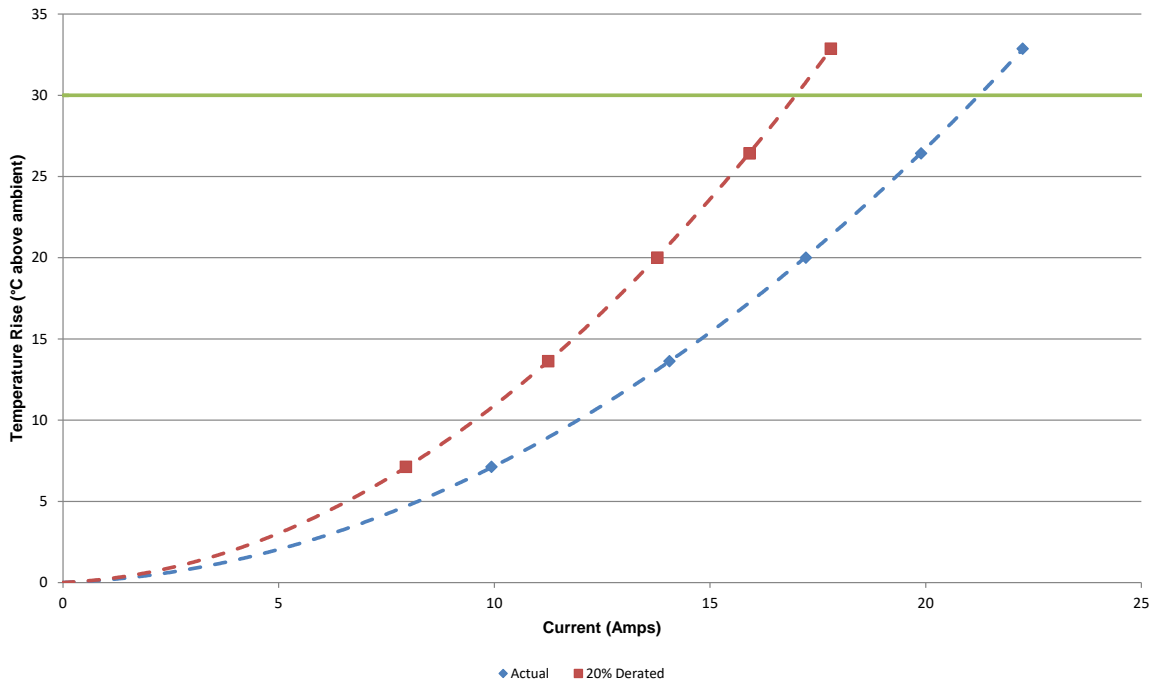

### DATA SUMMARIES Continued

c. Linear configuration with 3 adjacent conductors/contacts powered

3467354  
 3(1X3) Contacts in Series(Contact Interface)  
 Part Numbers:UMPE-10-T-16-12.0/UMPI-10-T-16-12.0

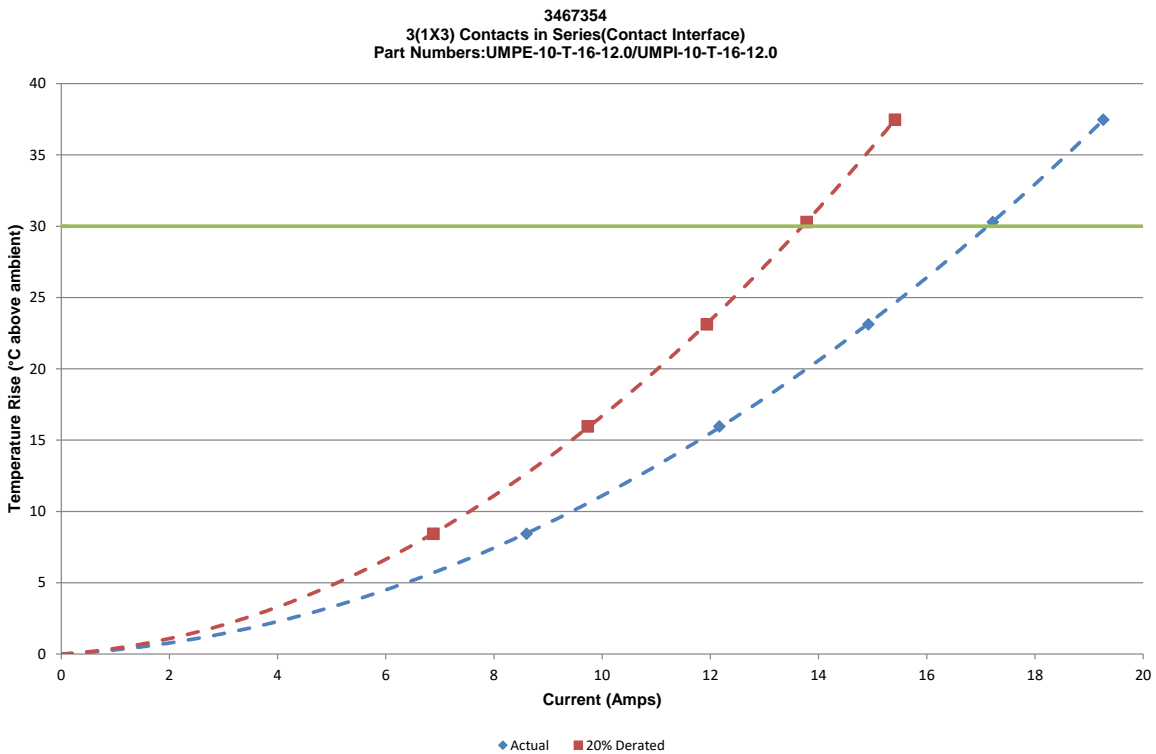
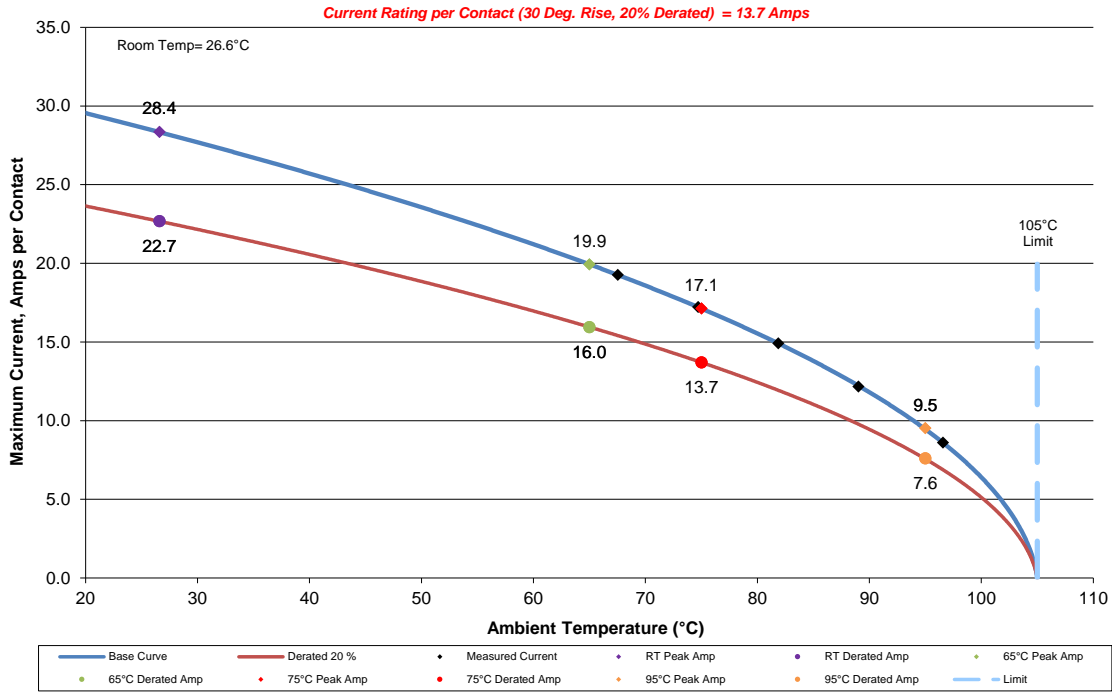

### DATA SUMMARIES Continued

d. Linear configuration with 4 adjacent conductors/contacts powered

3467354  
 4(1X4) Contacts in Series(Contact Interface)  
 Part Numbers:UMPE-10-T-16-12.0/UMPI-10-T-16-12.0

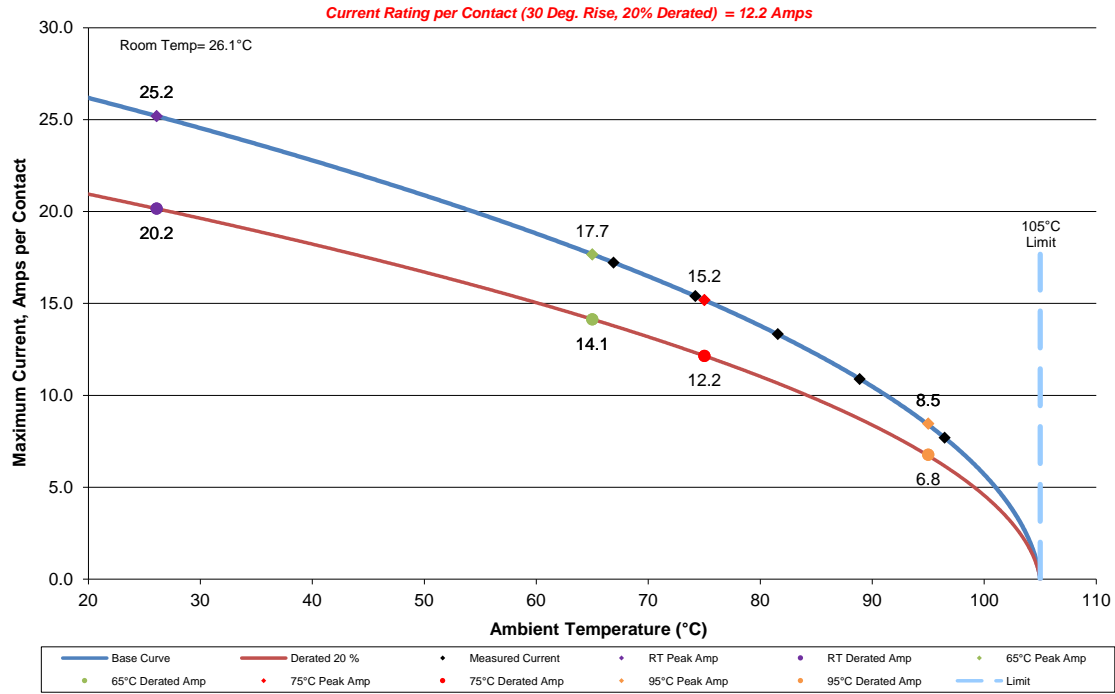

3467354  
 4(1X4) Contacts in Series(Contact Interface)  
 Part Numbers:UMPE-10-T-16-12.0/UMPI-10-T-16-12.0

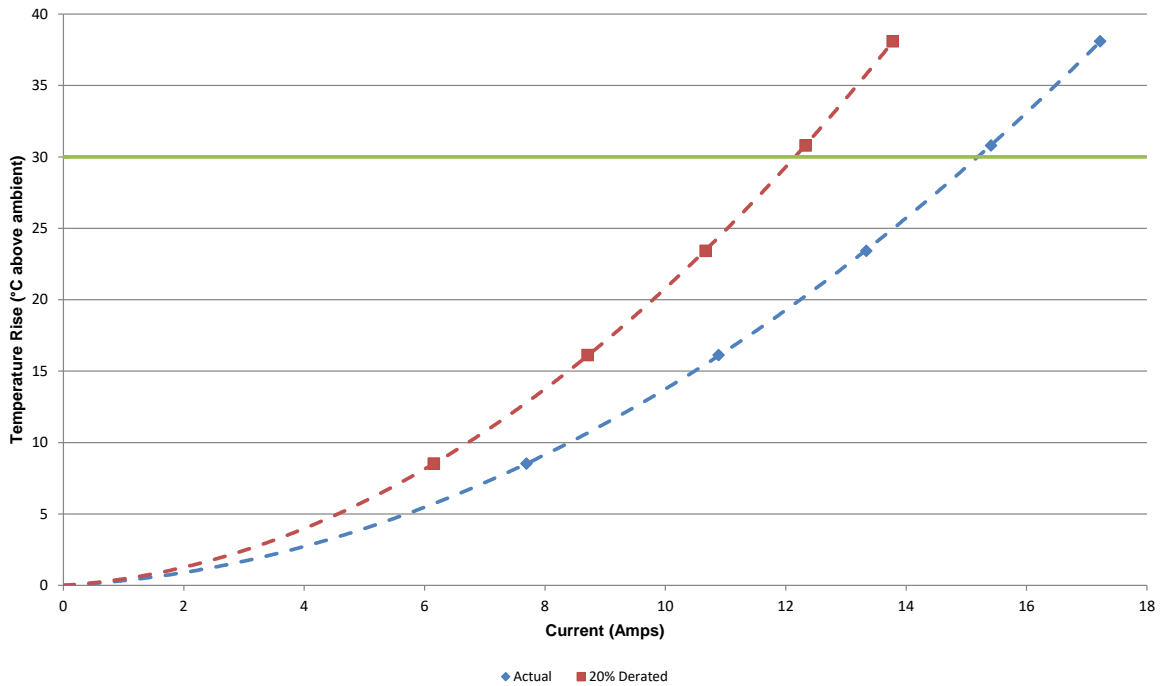

### DATA SUMMARIES Continued

e. Linear configuration with all adjacent conductors/contacts powered

3467354  
 10(1X10) Contacts in Series(Contact Interface)  
 Part Numbers:UMPE-10-T-16-12.0/UMPI-10-T-16-12.0

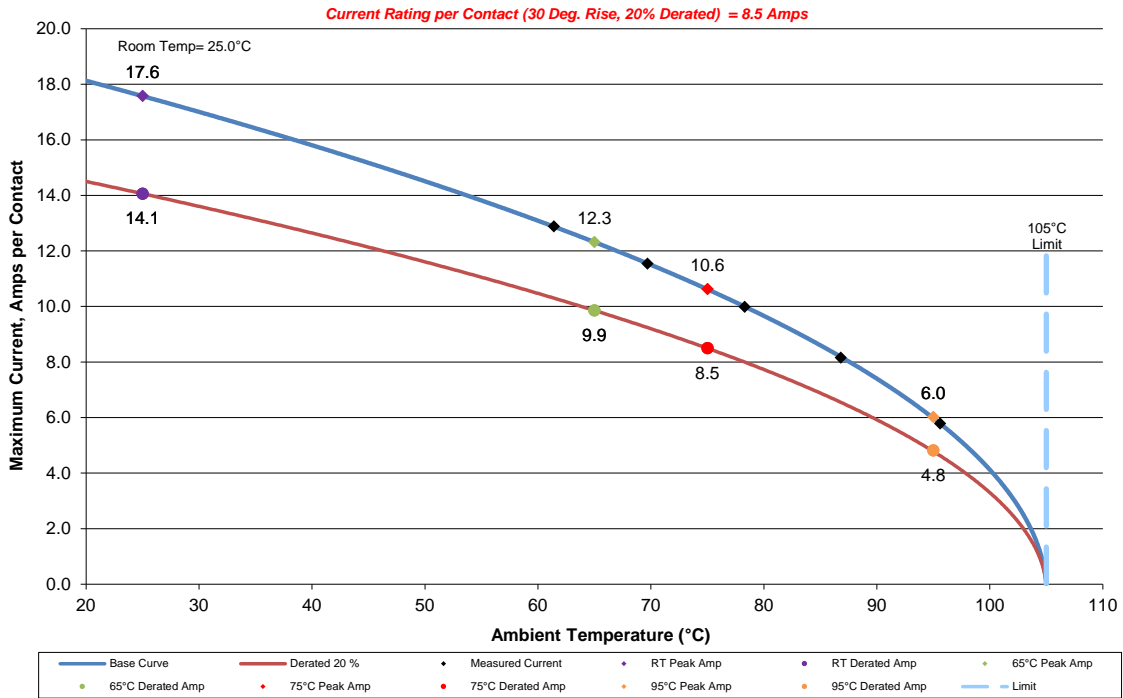

3467354  
 10(1X10) Contacts in Series(Contact Interface)  
 Part Numbers:UMPE-10-T-16-12.0/UMPI-10-T-16-12.0

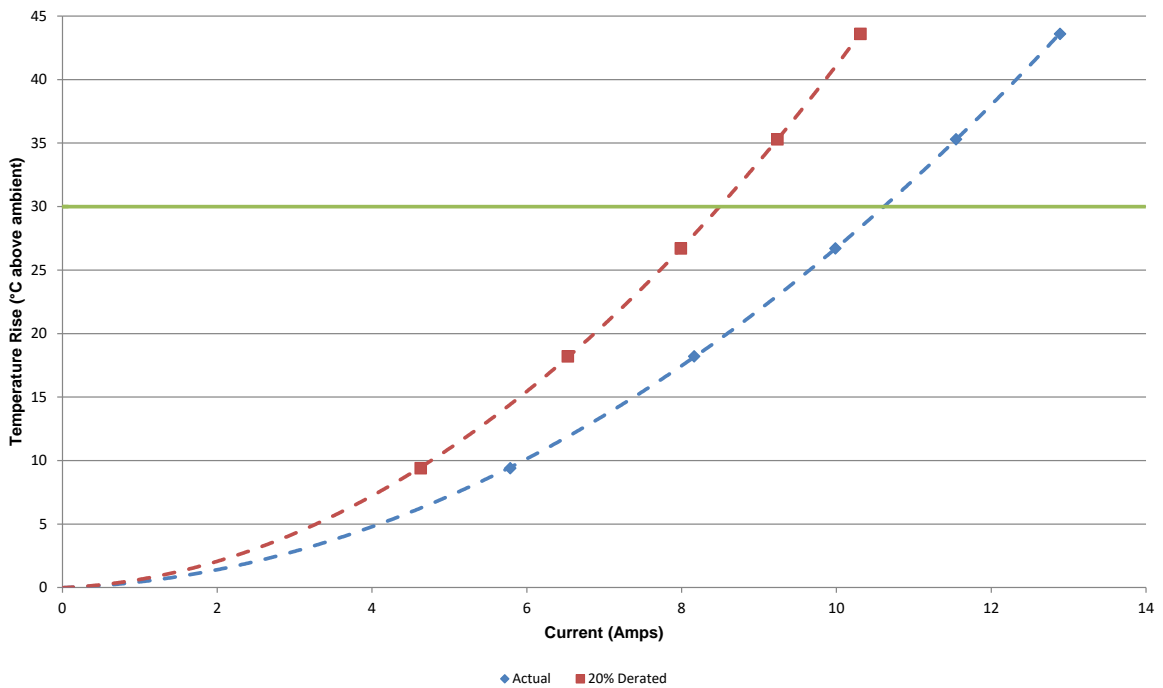

### DATA SUMMARIES Continued

#### UMPE-10-T-18-12.0/UMPI-10-T-18-12.0

a. Linear configuration with 1 adjacent conductors/contacts powered

3467354  
1(1X1) Contacts in Series(Contact Interface)  
Part Numbers:UMPE-10-T-18-12.0/UMPI-10-T-18-12.0

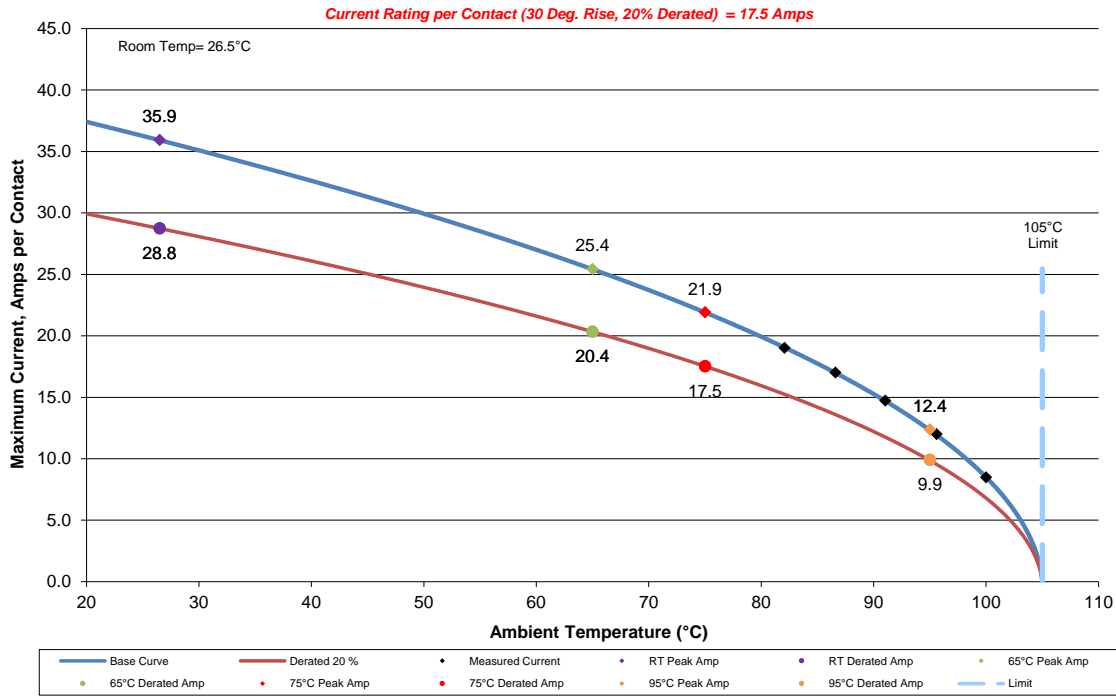

3467354  
1(1X1) Contacts in Series(Contact Interface)  
Part Numbers:UMPE-10-T-18-12.0/UMPI-10-T-18-12.0

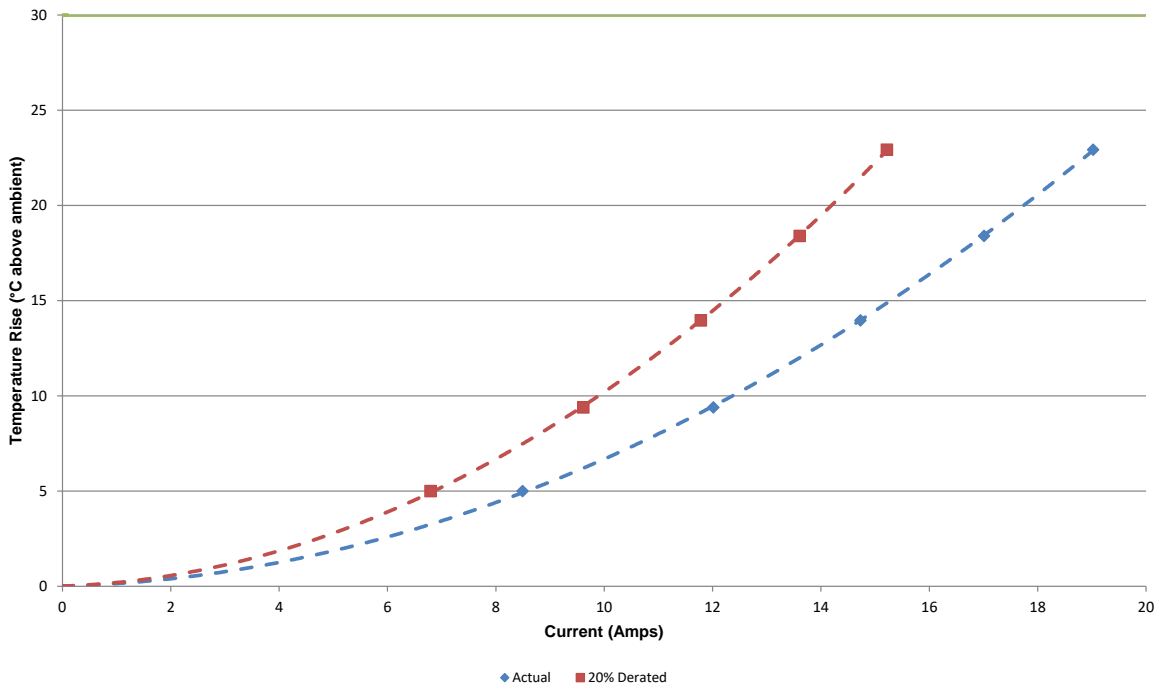

### DATA SUMMARIES Continued

b. Linear configuration with 2 adjacent conductors/contacts powered

3467354  
 2(1X2) Contacts in Series(Contact Interface)  
 Part Numbers:UMPE-10-T-18-12.0/UMPI-10-T-18-12.0

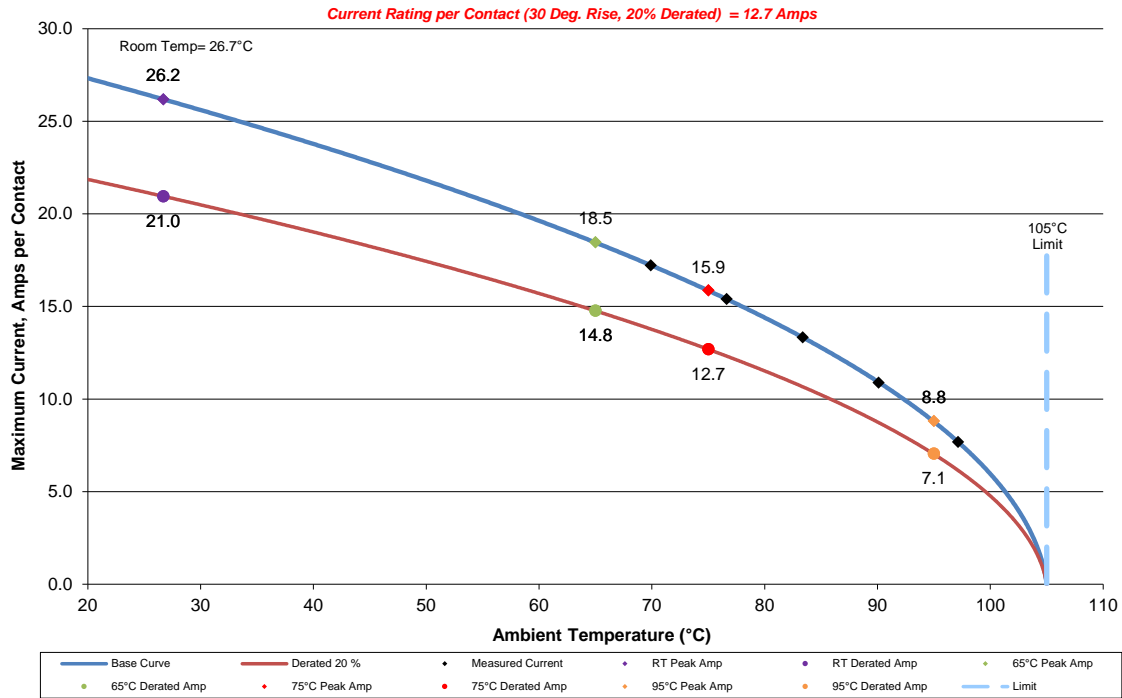

3467354  
 2(1X2) Contacts in Series(Contact Interface)  
 Part Numbers:UMPE-10-T-18-12.0/UMPI-10-T-18-12.0

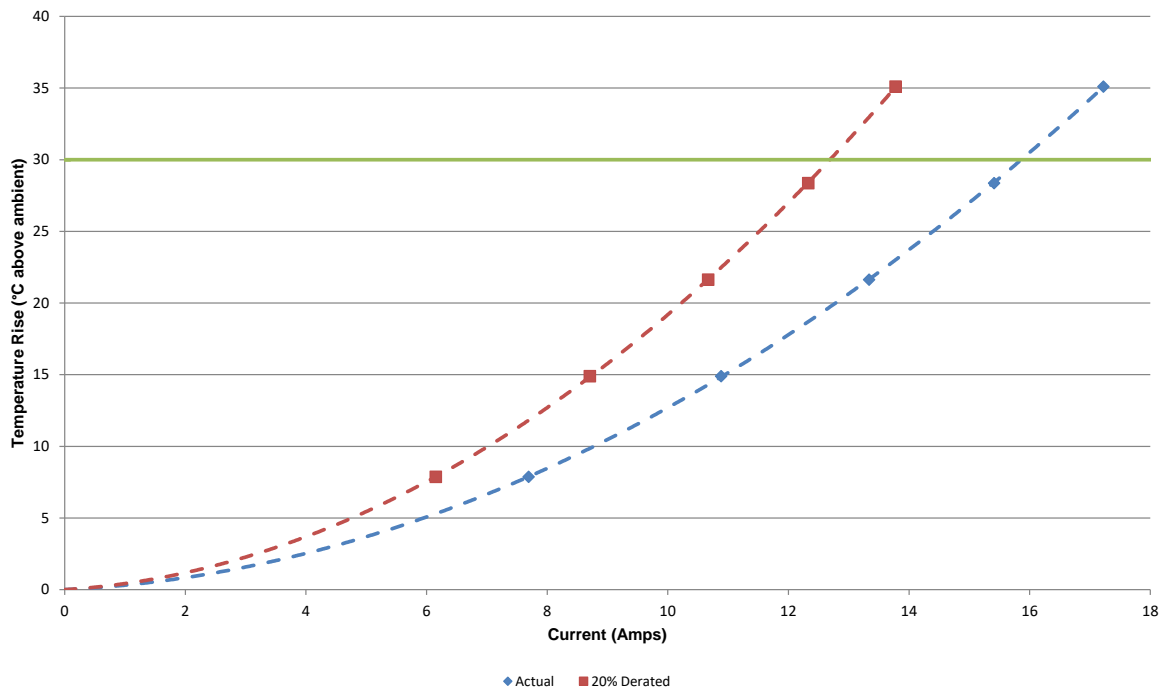

### DATA SUMMARIES Continued

c. Linear configuration with 3 adjacent conductors/contacts powered

3467354  
 3(1X3) Contacts in Series(Contact Interface)  
 Part Numbers:UMPE-10-T-18-12.0/UMPI-10-T-18-12.0

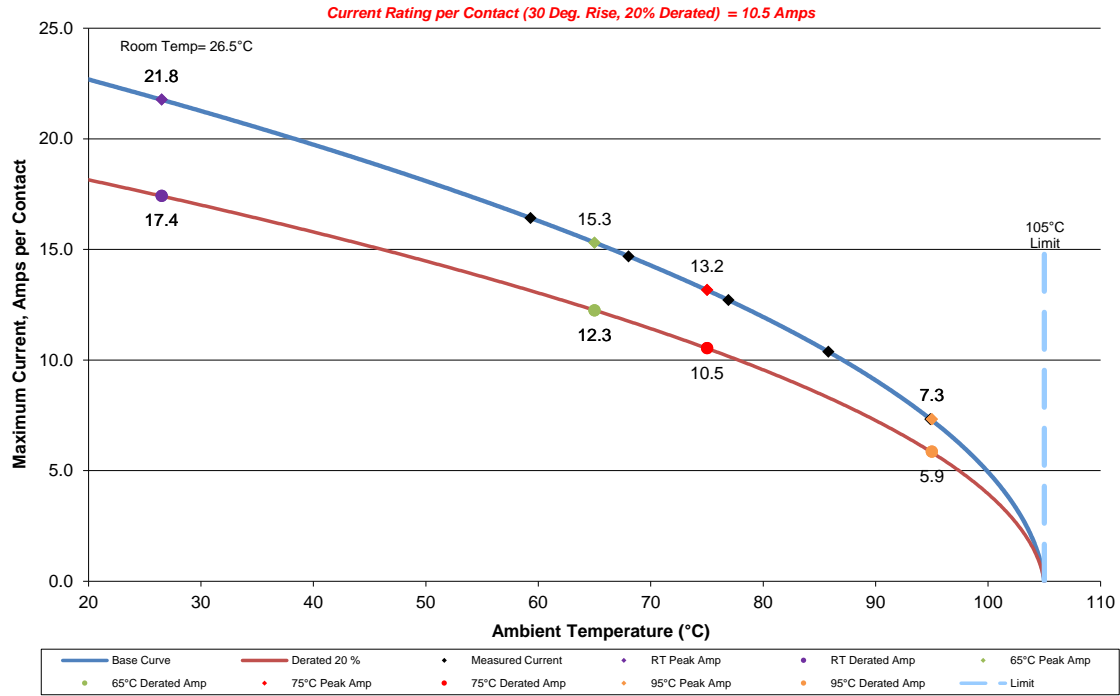

3467354  
 3(1X3) Contacts in Series(Contact Interface)  
 Part Numbers:UMPE-10-T-18-12.0/UMPI-10-T-18-12.0

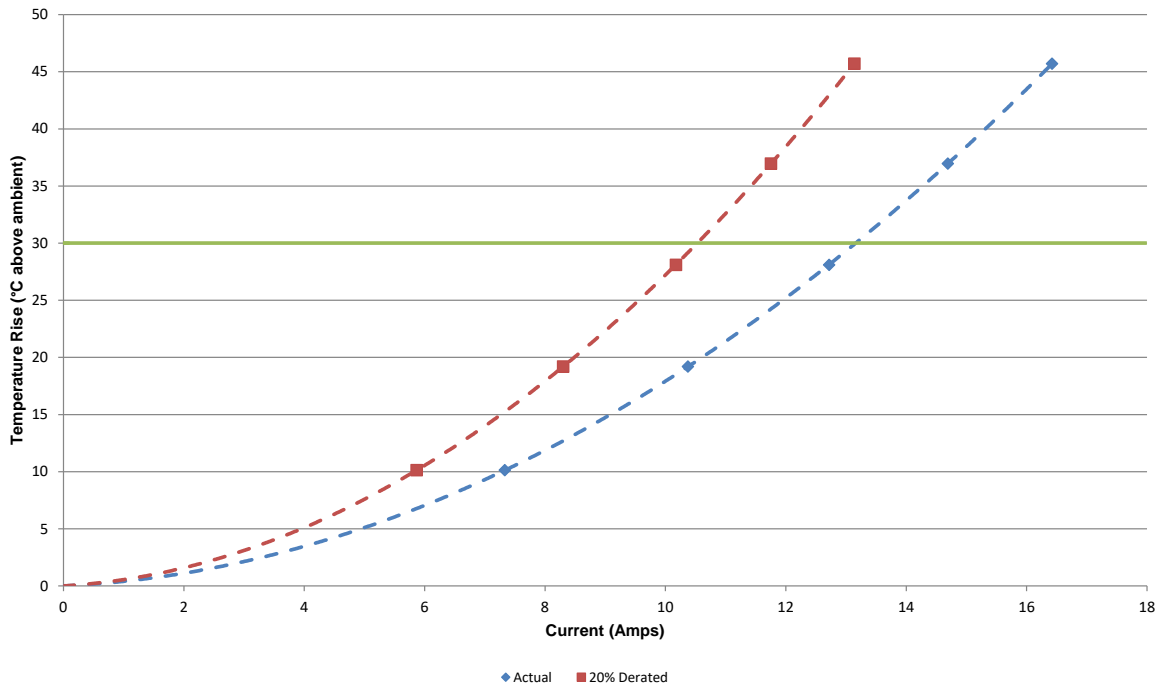

### DATA SUMMARIES Continued

d. Linear configuration with 4 adjacent conductors/contacts powered

3467354  
 4(1X4) Contacts in Series(Contact Interface)  
 Part Numbers:UMPE-10-T-18-12.0/UMPI-10-T-18-12.0

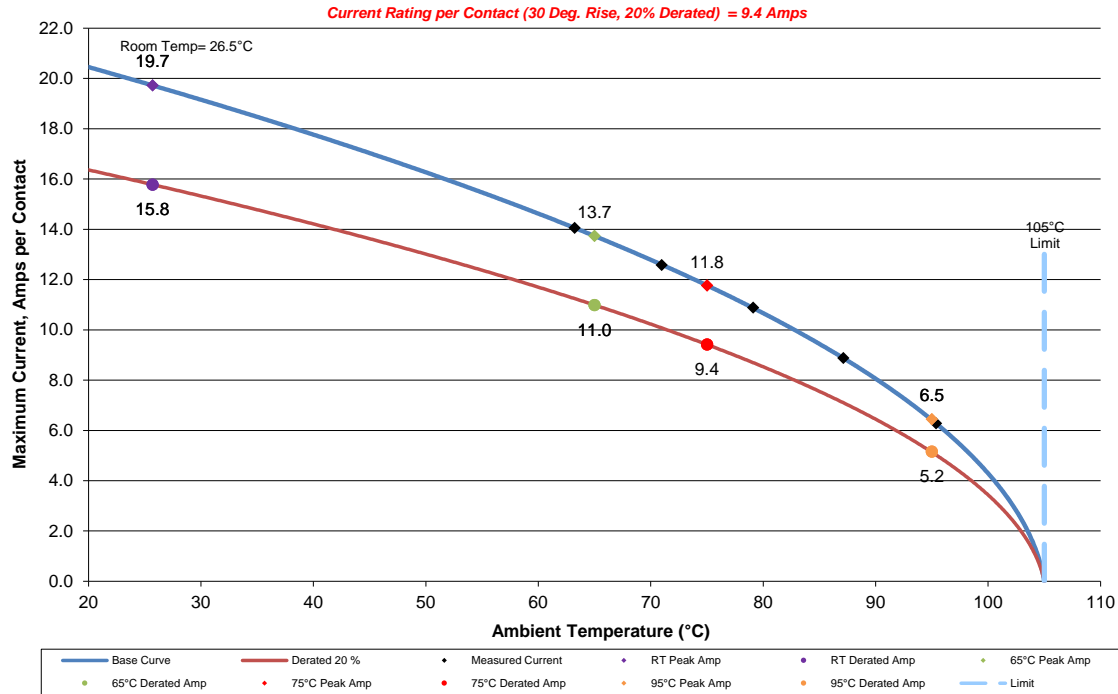

3467354  
 4(1X4) Contacts in Series(Contact Interface)  
 Part Numbers:UMPE-10-T-18-12.0/UMPI-10-T-18-12.0

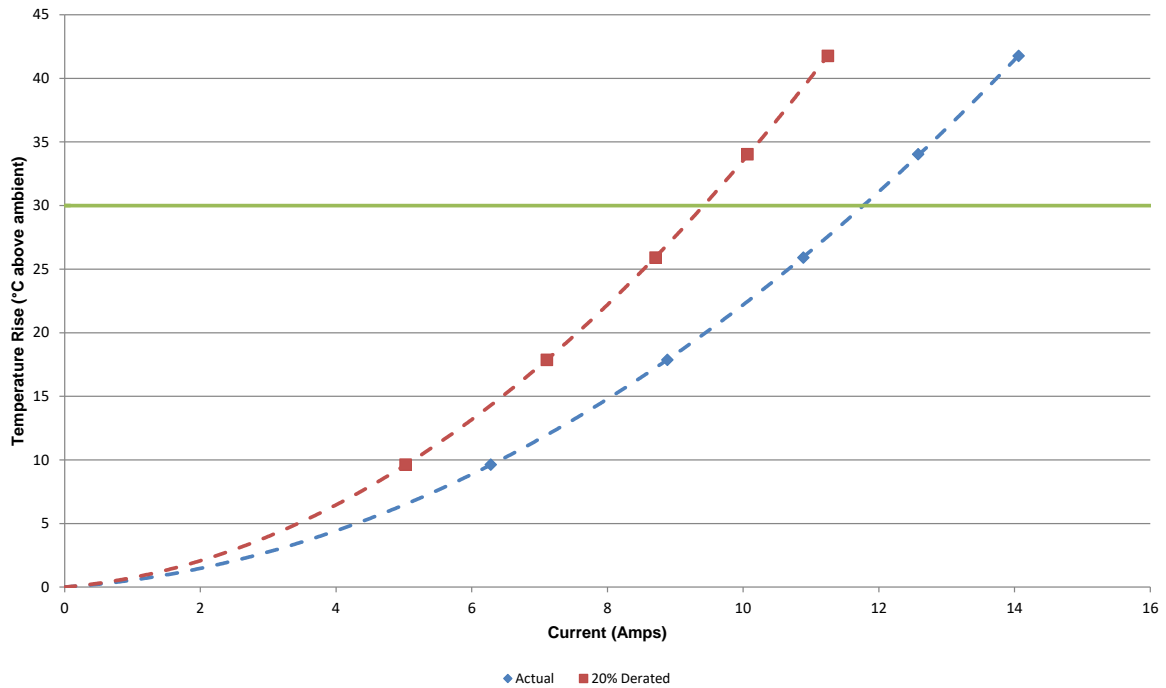

### DATA SUMMARIES Continued

e. Linear configuration with all adjacent conductors/contacts powered

3467354  
 10(1X10) Contacts in Series(Contact Interface)  
 Part Numbers:UMPE-10-T-18-12.0/UMPI-10-T-18-12.0

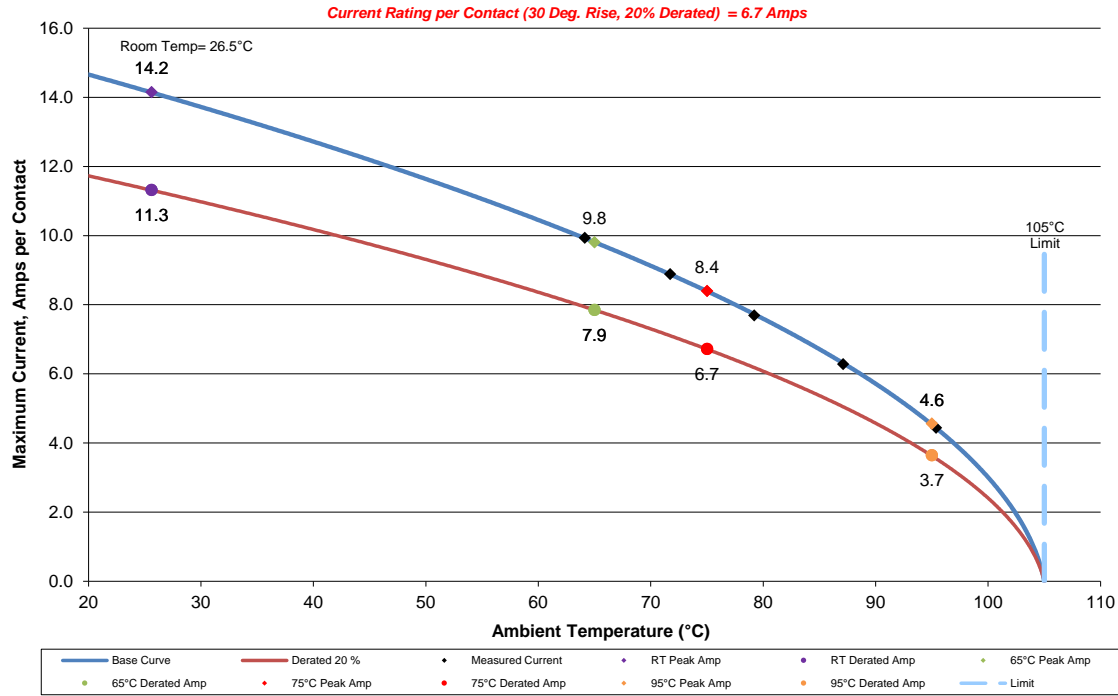

3467354  
 10(1X10) Contacts in Series(Contact Interface)  
 Part Numbers:UMPE-10-T-18-12.0/UMPI-10-T-18-12.0

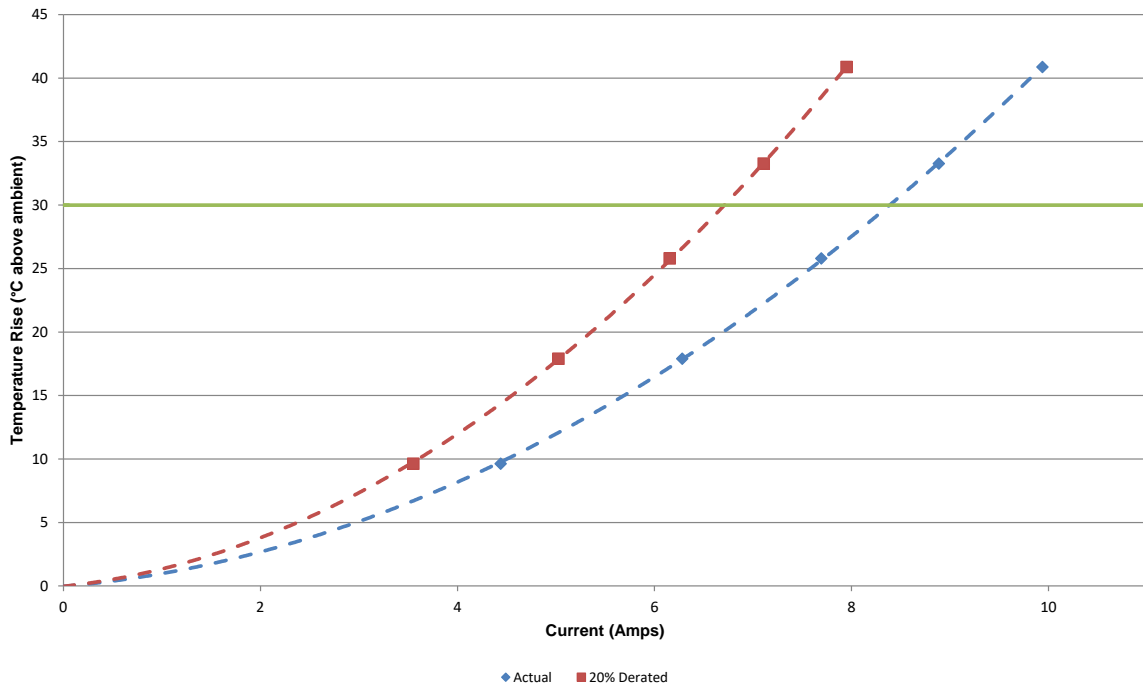

### DATA SUMMARIES Continued

#### UMPE-10-S-16-12.0/UMPI-10-S-16-12.0

a. Linear configuration with 1 adjacent conductors/contacts powered

3467354  
1(1X1) Contacts in Series(Contact Interface)  
Part Numbers:UMPE-10-S-16-12.0/UMPI-10-S-16-12.0

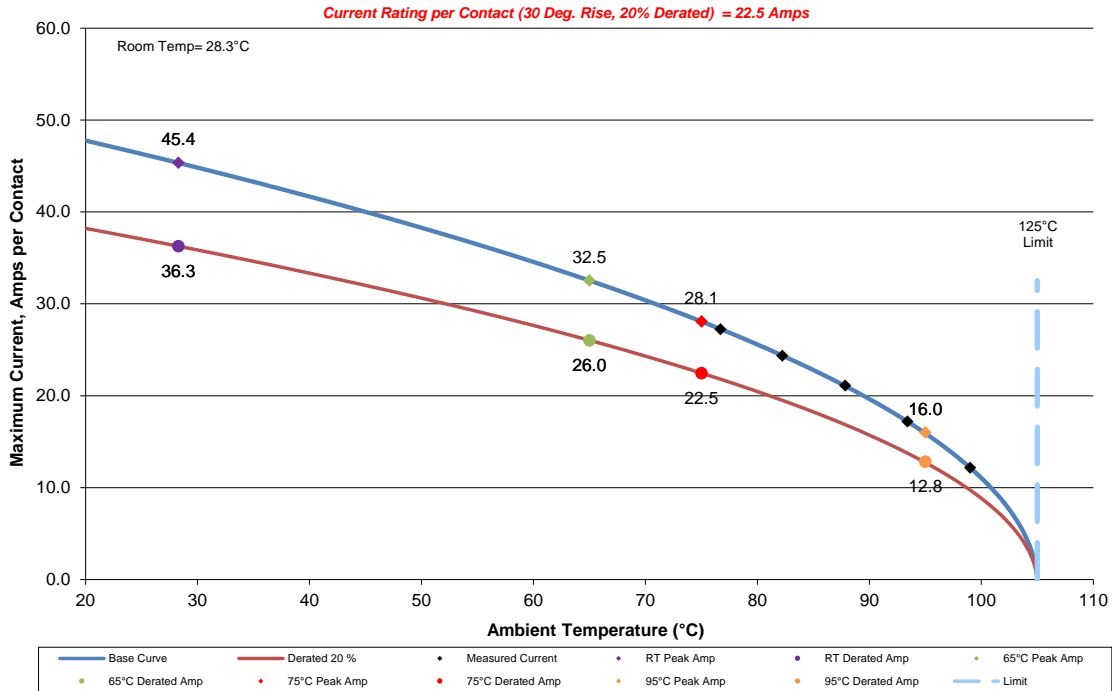

3467354  
1(1X1) Contacts in Series(Contact Interface)  
Part Numbers:UMPE-10-S-16-12.0/UMPI-10-S-16-12.0

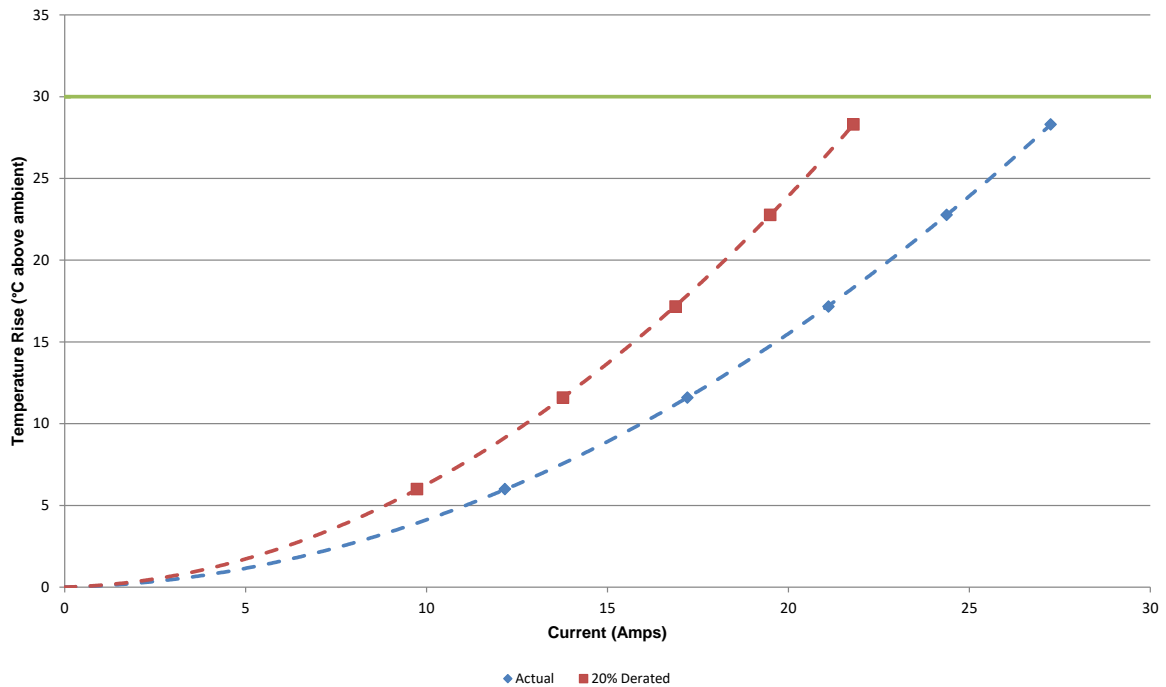

### DATA SUMMARIES Continued

b. Linear configuration with 2 adjacent conductors/contacts powered

3467354  
 2(1X2) Contacts in Series(Contact Interface)  
 Part Numbers:UMPE-10-S-16-12.0/UMPI-10-S-16-12.0

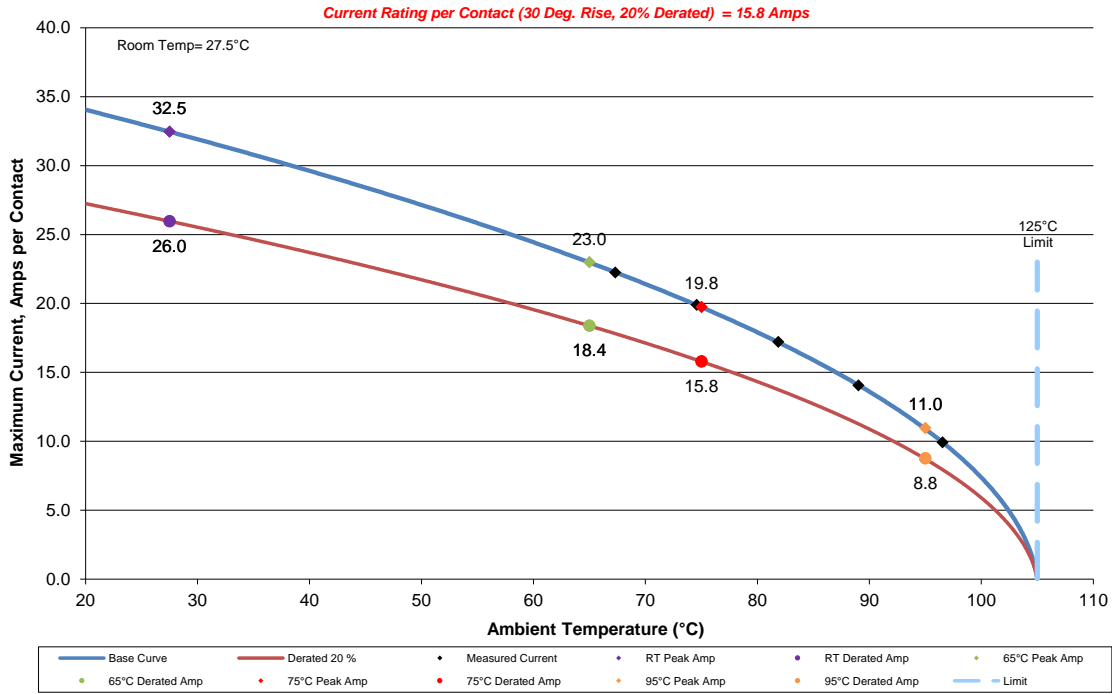

3467354  
 2(1X2) Contacts in Series(Contact Interface)  
 Part Numbers:UMPE-10-S-16-12.0/UMPI-10-S-16-12.0

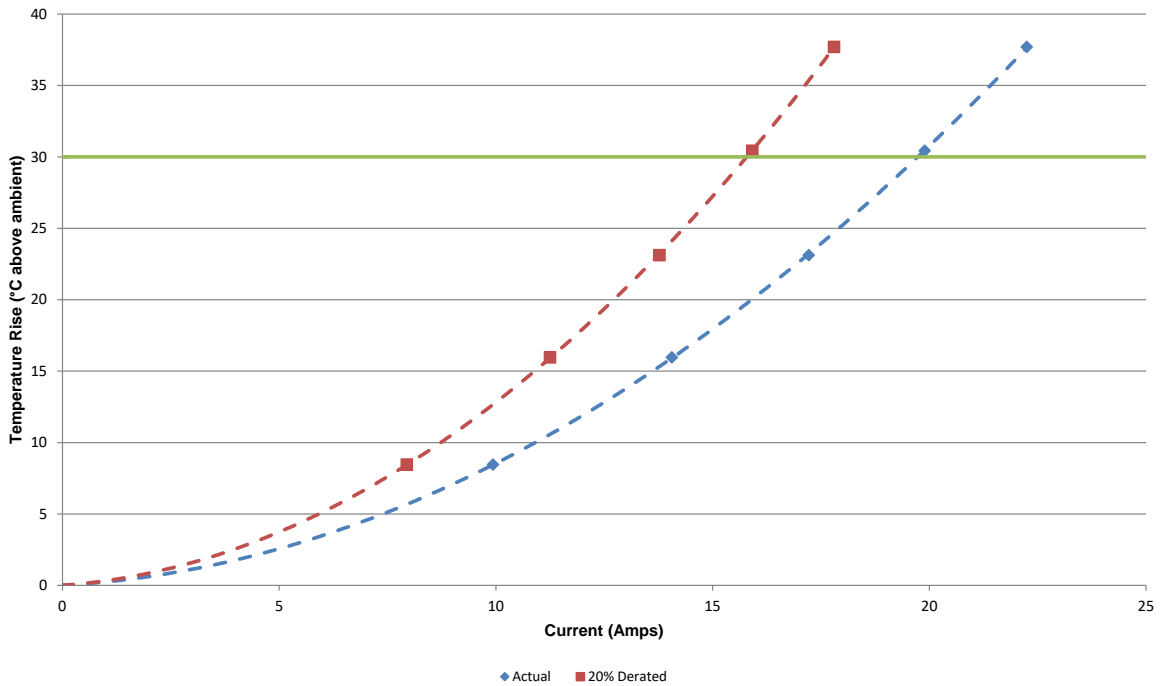

### DATA SUMMARIES Continued

c. Linear configuration with 3 adjacent conductors/contacts powered

3467354  
 3(1X3) Contacts in Series(Contact Interface)  
 Part Numbers:UMPE-10-S-16-12.0/UMPI-10-S-16-12.0

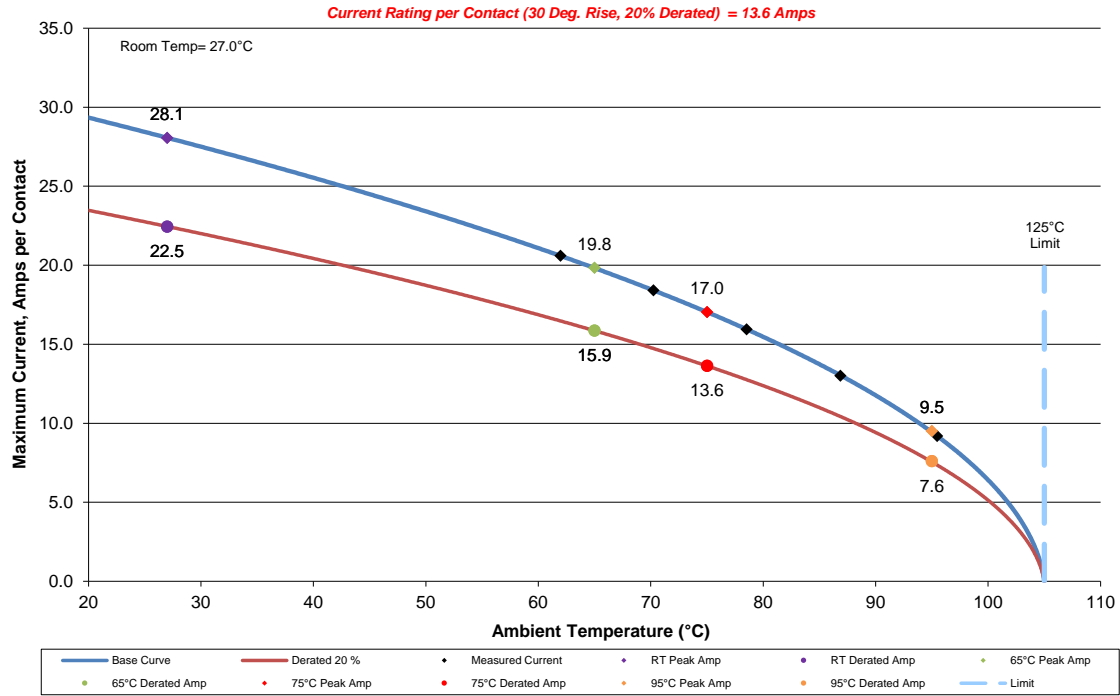

3467354  
 3(1X3) Contacts in Series(Contact Interface)  
 Part Numbers:UMPE-10-S-16-12.0/UMPI-10-S-16-12.0

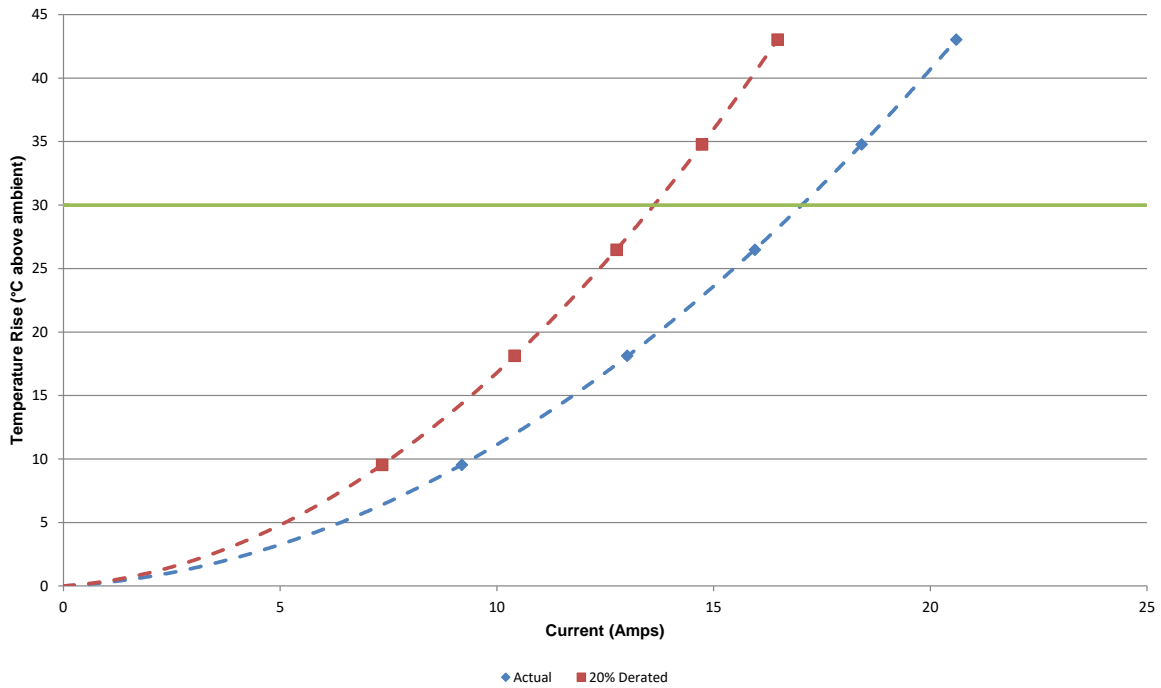

### DATA SUMMARIES Continued

d. Linear configuration with 4 adjacent conductors/contacts powered

3467354  
 4(1X4) Contacts in Series(Contact Interface)  
 Part Numbers:UMPE-10-S-16-12.0/UMPI-10-S-16-12.0

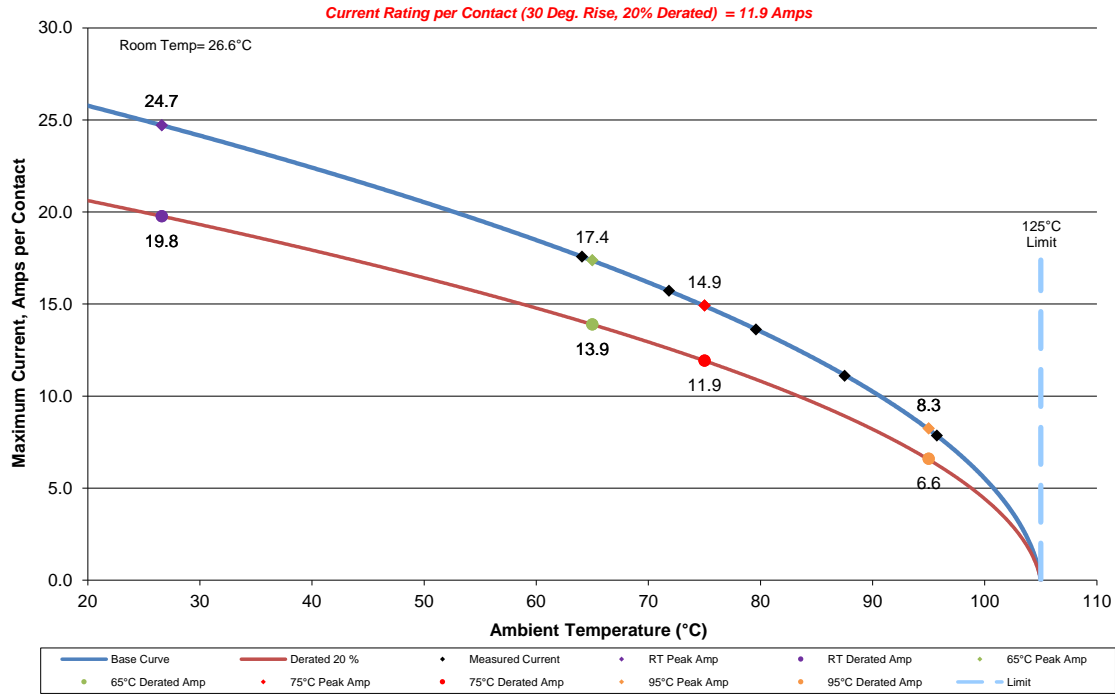

3467354  
 4(1X4) Contacts in Series(Contact Interface)  
 Part Numbers:UMPE-10-S-16-12.0/UMPI-10-S-16-12.0

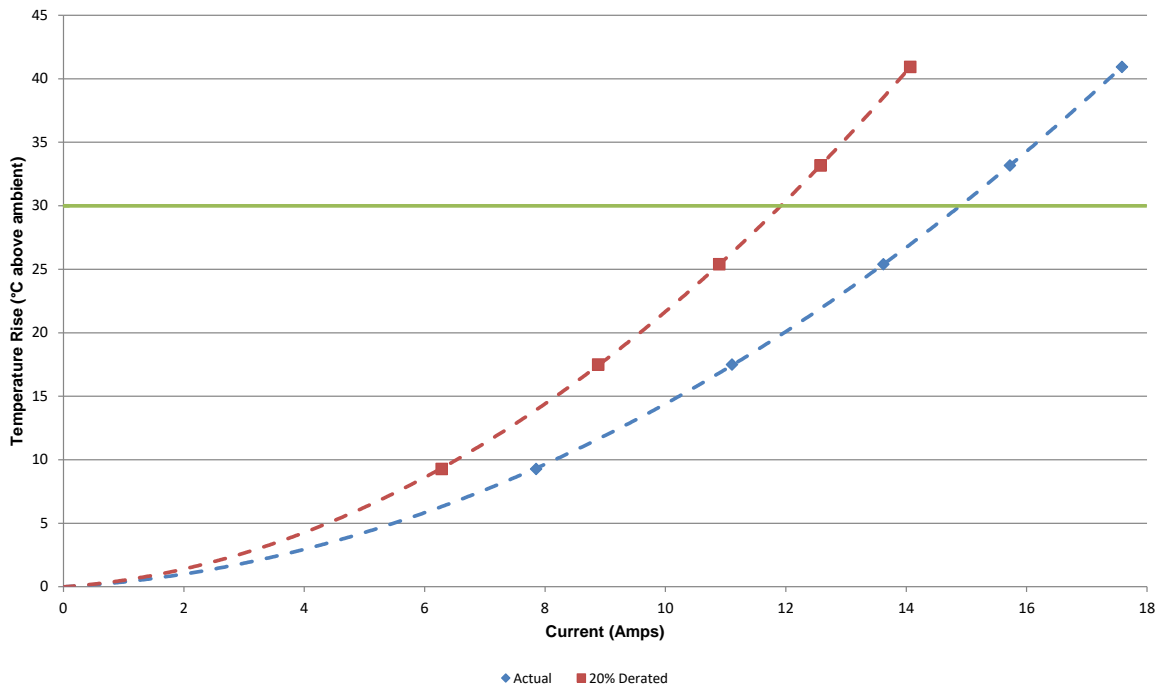

### DATA SUMMARIES Continued

e. Linear configuration with all adjacent conductors/contacts powered

3467354  
 10(1X10) Contacts in Series(Contact Interface)  
 Part Numbers:UMPE-10-S-16-12.0/UMPI-10-S-16-12.0

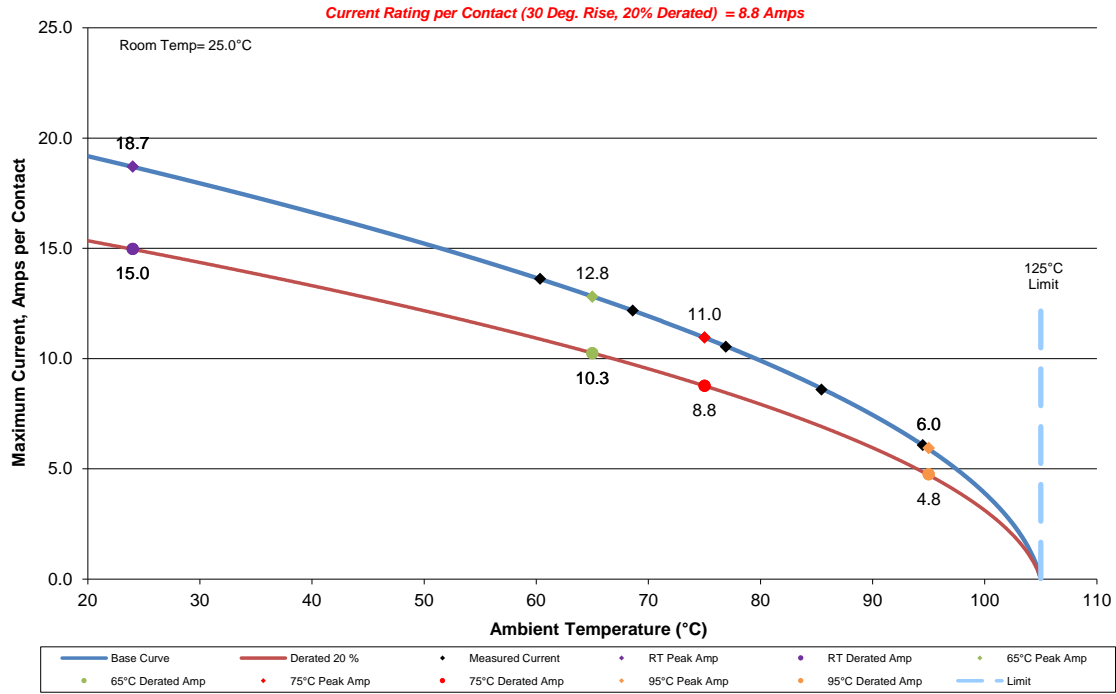

3467354  
 10(1X10) Contacts in Series(Contact Interface)  
 Part Numbers:UMPE-10-S-16-12.0/UMPI-10-S-16-12.0

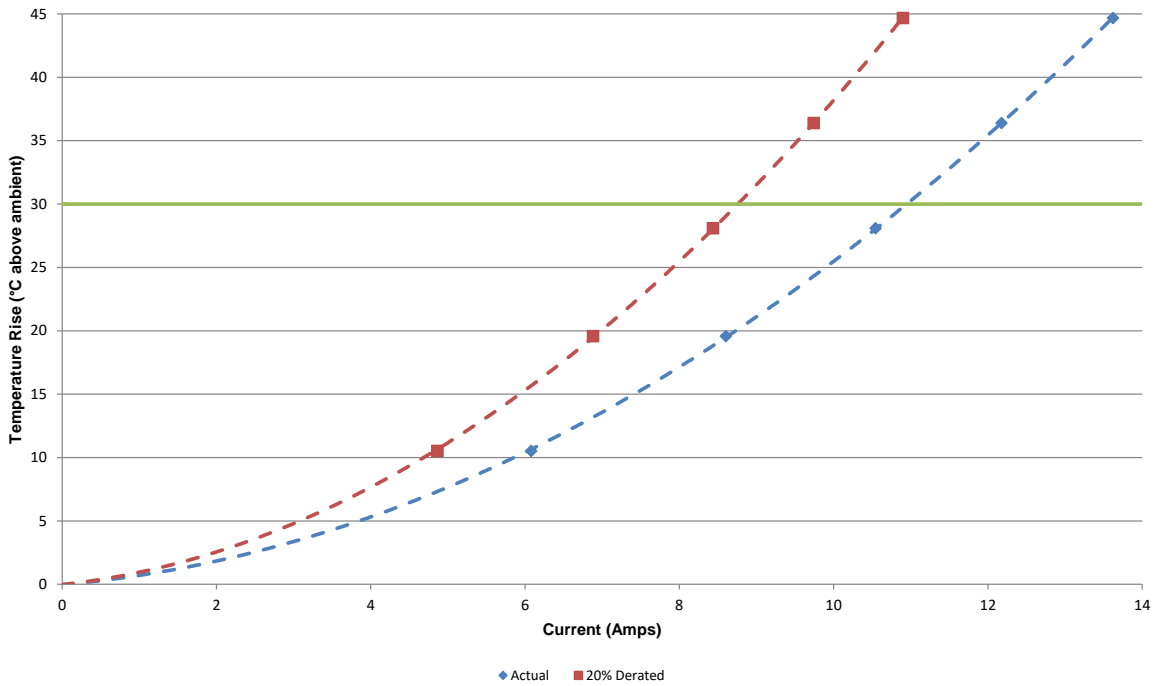

**DATA SUMMARIES Continued****MATING-UNMATING FORCE:****Thermal Aging Group**

	Initial				After Thermals			
	Mating		Unmating		Mating		Unmating	
	Newton's	Force (Lbs)	Newton's	Force (Lbs)	Newton's	Force (Lbs)	Newton's	Force (Lbs)
Minimum	17.61	3.96	11.97	2.69	10.36	2.33	8.90	2.00
Maximum	19.57	4.40	17.17	3.86	14.41	3.24	14.54	3.27
<b>Average</b>	18.39	<b>4.14</b>	13.26	<b>2.98</b>	12.03	<b>2.70</b>	11.20	<b>2.52</b>
St Dev	0.70	0.16	1.72	0.39	1.51	0.34	1.74	0.39
Count	8	8	8	8	8	8	8	8

**Mating-Unmating Durability Group**

	Initial				25 Cycles			
	Mating		Unmating		Mating		Unmating	
	Newton's	Force (Lbs)	Newton's	Force (Lbs)	Newton's	Force (Lbs)	Newton's	Force (Lbs)
Minimum	15.92	3.58	10.68	2.40	20.02	4.50	17.93	4.03
Maximum	19.48	4.38	17.53	3.94	25.71	5.78	21.48	4.83
<b>Average</b>	17.70	<b>3.98</b>	13.44	<b>3.02</b>	22.35	<b>5.03</b>	19.50	<b>4.38</b>
St Dev	1.43	0.32	2.28	0.51	1.87	0.42	1.18	0.26
Count	8	8	8	8	8	8	8	8
	50 Cycles				75 Cycles			
	Mating		Unmating		Mating		Unmating	
	Newton's	Force (Lbs)	Newton's	Force (Lbs)	Newton's	Force (Lbs)	Newton's	Force (Lbs)
Minimum	22.86	5.14	17.08	3.84	18.37	4.13	15.43	3.47
Maximum	28.60	6.43	24.42	5.49	25.49	5.73	23.31	5.24
<b>Average</b>	25.45	<b>5.72</b>	19.03	<b>4.28</b>	21.43	<b>4.82</b>	17.14	<b>3.85</b>
St Dev	1.76	0.39	2.29	0.52	2.19	0.49	2.54	0.57
Count	8	8	8	8	8	8	8	8
	100 Cycles				After Humidity			
	Mating		Unmating		Mating		Unmating	
	Newton's	Force (Lbs)	Newton's	Force (Lbs)	Newton's	Force (Lbs)	Newton's	Force (Lbs)
Minimum	19.22	4.32	15.48	3.48	11.48	2.58	9.65	2.17
Maximum	24.86	5.59	22.55	5.07	13.43	3.02	11.48	2.58
<b>Average</b>	21.11	<b>4.75</b>	17.29	<b>3.89</b>	12.49	<b>2.81</b>	10.57	<b>2.38</b>
St Dev	1.73	0.39	2.21	0.50	0.65	0.15	0.67	0.15
Count	8	8	8	8	8	8	8	8

**DATA SUMMARIES Continued****Mating-Unmating Basic (UMPE-02-T-16-04.0-S-M1\UMPI-02-T-16-05.0-M1)**

	Initial				After 25 Cycles			
	Mating		Unmating		Mating		Unmating	
	Newton's	Force (Lbs)	Newton's	Force (Lbs)	Newton's	Force (Lbs)	Newton's	Force (Lbs)
Minimum	6.41	1.44	4.71	1.06	9.12	2.05	9.39	2.11
Maximum	11.79	2.65	8.32	1.87	13.48	3.03	11.25	2.53
<b>Average</b>	8.12	<b>1.83</b>	6.47	<b>1.46</b>	11.23	<b>2.52</b>	10.20	<b>2.29</b>
St Dev	1.65	0.37	1.33	0.30	1.27	0.29	0.59	0.13
Count	8	8	8	8	8	8	8	8
	After 50 Cycles				After 75 Cycles			
	Mating		Unmating		Mating		Unmating	
	Newton's	Force (Lbs)	Newton's	Force (Lbs)	Newton's	Force (Lbs)	Newton's	Force (Lbs)
Minimum	11.34	2.55	9.83	2.21	10.19	2.29	8.27	1.86
Maximum	15.48	3.48	11.56	2.60	12.01	2.70	9.61	2.16
<b>Average</b>	12.78	<b>2.87</b>	10.50	<b>2.36</b>	11.37	<b>2.56</b>	9.12	<b>2.05</b>
St Dev	1.26	0.28	0.60	0.14	0.66	0.15	0.42	0.10
Count	8	8	8	8	8	8	8	8
	After 100 Cycles							
	Mating		Unmating					
	Newton's	Force (Lbs)	Newton's	Force (Lbs)				
Minimum	9.79	2.20	8.23	1.85				
Maximum	11.74	2.64	9.16	2.06				
<b>Average</b>	10.48	<b>2.36</b>	8.88	<b>2.00</b>				
St Dev	0.65	0.15	0.32	0.07				
Count	8	8	8	8				

**DATA SUMMARIES Continued****Mating-Unmating Basic (UMPE-10-T-16-04.0-S-M1\UMPI-10-T-16-05.0-M1)**

	Initial				After 25 Cycles			
	Mating		Unmating		Mating		Unmating	
	Newton's	Force (Lbs)	Newton's	Force (Lbs)	Newton's	Force (Lbs)	Newton's	Force (Lbs)
Minimum	47.15	10.60	28.87	6.49	49.73	11.18	45.77	10.29
Maximum	55.02	12.37	38.34	8.62	60.80	13.67	48.84	10.98
<b>Average</b>	49.67	<b>11.17</b>	33.64	<b>7.56</b>	54.63	<b>12.28</b>	46.94	<b>10.55</b>
St Dev	2.42	0.54	3.67	0.82	3.69	0.83	1.25	0.28
Count	8	8	8	8	8	8	8	8
	After 50 Cycles				After 75 Cycles			
	Mating		Unmating		Mating		Unmating	
	Newton's	Force (Lbs)	Newton's	Force (Lbs)	Newton's	Force (Lbs)	Newton's	Force (Lbs)
Minimum	54.71	12.30	44.52	10.01	52.13	11.72	41.23	9.27
Maximum	68.77	15.46	53.06	11.93	63.47	14.27	47.28	10.63
<b>Average</b>	62.83	<b>14.13</b>	47.44	<b>10.67</b>	57.60	<b>12.95</b>	43.48	<b>9.78</b>
St Dev	4.86	1.09	2.93	0.66	4.10	0.92	1.98	0.45
Count	8	8	8	8	8	8	8	8
	After 100 Cycles							
	Mating		Unmating					
	Newton's	Force (Lbs)	Newton's	Force (Lbs)				
Minimum	48.44	10.89	39.68	8.92				
Maximum	60.27	13.55	48.62	10.93				
<b>Average</b>	54.84	<b>12.33</b>	42.71	<b>9.60</b>				
St Dev	4.52	1.02	2.81	0.63				
Count	8	8	8	8				

**Cable Pull Force:****0° Pull**

	Force (lbs)
Minimum	<b>13.66</b>
Maximum	17.72
Average	15.63

**90° Pull**

	Force (lbs)
Minimum	<b>12.29</b>
Maximum	13.58
Average	12.94

**DATA SUMMARIES Continued****Latch Pull Force**

	Force (lbs)
Minimum	<b>15.74</b>
Maximum	21.42
Average	18.63

**INSULATION RESISTANCE (IR):**

	Pin to Pin		
	Mated	Unmated	Unmated
Minimum	<b>UMPE/UMPI</b>	<b>UMPE</b>	<b>UMPI</b>
<b>Initial</b>	45000	45000	45000
<b>Thermal</b>	45000	45000	45000
<b>Humidity</b>	12500	34000	45000

**DIELECTRIC WITHSTANDING VOLTAGE (DWV):**

Voltage Rating Summary	
Minimum	UMPE/UMPI
<b>Break Down Voltage</b>	1776
<b>Test Voltage</b>	1335
<b>Working Voltage</b>	445

Pin to Pin	
<b>Initial Test Voltage</b>	Passed
<b>After Thermal Test Voltage</b>	Passed
<b>After Humidity Test Voltage</b>	Passed

**Cable Flex:****Insulation Resistance minimums, IR**

Pin to Pin	
Mated	
Minimum	
<b>Initial</b>	45000
<b>After 500 Flex Cycles</b>	45000

**Dielectric Withstanding Voltage minimums, DWV**

Voltage Rating Summary	
Minimum	UMPE/UMPI
<b>Test Voltage</b>	1335

Pin to Pin	
<b>Initial Test Voltage</b>	Passed
<b>After 500 Flex Cycles Test Voltage</b>	Passed

**DATA SUMMARIES Continued**

**Gas Tight:**

- 1) A total of 32 points were measured.
- 2) EIA-364-23, *Low Level Contact Resistance Test Procedure for Electrical Connectors and Sockets*.
- 3) A computer program, *LLCR 221.exe*, ensures repeatability for data acquisition.
- 4) The following guidelines are used to categorize the changes in LLCR as a result from stressing.
  - a.  $\leq +1.0$  mOhms:-----Stable
  - b.  $+1.1$  to  $+2.0$  mOhms: -----Minor
  - c.  $+2.1$  to  $+5.0$  mOhms: -----Acceptable
  - d.  $+5.1$  to  $+15.0$  mOhms: -----Marginal
  - e.  $+15.1$  to  $+1000$  mOhms:-----Unstable
  - f.  $>+1000$  mOhms:-----Open Failure

<b>LLCR Measurement Summaries by Pin Type</b>				
Date	2022/9/28	2022/9/30		
Room Temp (Deg C)	22	22		
Rel Humidity (%)	52	52		
Technician	Kason He	Kason He		
<b>mOhm values</b>	<b>Actual Initial</b>	<b>Delta Acid Vapor</b>	<b>Delta</b>	<b>Delta</b>
<b>Pin Type 1: Signal</b>				
Average	4.50	0.23		
St. Dev.	0.11	0.21		
Min	4.34	0.00		
Max	4.78	0.89		
Summary Count	32	32		
Total Count	32	32		

<b>LLCR Delta Count by Category</b>						
	Stable	Minor	Acceptable	Marginal	Unstable	Open
mOhms	$\leq 1$	$>1 \ \& \ \leq 2$	$>2 \ \& \ \leq 5$	$>5 \ \& \ \leq 15$	$>15 \ \& \ \leq 1000$	$>1000$
<b>Acid Vapor</b>	<b>32</b>	<b>0</b>	<b>0</b>	<b>0</b>	<b>0</b>	<b>0</b>

**DATA SUMMARIES Continued**

**LLCR Thermal Aging Group**

- 1) A total of 32 points were measured.
- 2) EIA-364-23, *Low Level Contact Resistance Test Procedure for Electrical Connectors and Sockets*.
- 3) A computer program, *LLCR 221.exe*, ensures repeatability for data acquisition.
- 4) The following guidelines are used to categorize the changes in LLCR as a result from stressing.
  - a.  $\leq +1.0$  mOhms:-----Stable
  - b.  $+1.1$  to  $+2.0$  mOhms: -----Minor
  - c.  $+2.1$  to  $+5.0$  mOhms: -----Acceptable
  - d.  $+5.1$  to  $+15.0$  mOhms: -----Marginal
  - e.  $+15.1$  to  $+1000$  mOhms:-----Unstable
  - f.  $>+1000$  mOhms:-----Open Failure

<b>LLCR Measurement Summaries by Pin Type</b>				
Date	2022/9/2	2022/9/13		
Room Temp (Deg C)	22	22		
Rel Humidity (%)	52	52		
Technician	Kason He	Kason He		
<b>mOhm values</b>	<b>Actual Initial</b>	<b>Delta Thermal</b>	<b>Delta</b>	<b>Delta</b>
<b>Pin Type 1: Signal</b>				
Average	4.49	0.14		
St. Dev.	0.13	0.11		
Min	4.26	0.00		
Max	4.71	0.45		
Summary Count	32	32		
Total Count	32	32		

<b>LLCR Delta Count by Category</b>						
mOhms	Stable	Minor	Acceptable	Marginal	Unstable	Open
	$\leq 1$	$>1 \ \& \ \leq 2$	$>2 \ \& \ \leq 5$	$>5 \ \& \ \leq 15$	$>15 \ \& \ \leq 1000$	$>1000$
<b>Thermal</b>	<b>32</b>	<b>0</b>	<b>0</b>	<b>0</b>	<b>0</b>	<b>0</b>

**DATA SUMMARIES Continued****LLCR Mating/Unmating Durability Group**

- 1). A total of 32 points were measured.
- 2). EIA-364-23, *Low Level Contact Resistance Test Procedure for Electrical Connectors and Sockets*.
- 3). A computer program, *LLCR 221.exe*, ensures repeatability for data acquisition.
- 4). The following guidelines are used to categorize the changes in LLCR as a result from stressing.
  - a.  $\leq +1.0$  mOhms:-----Stable
  - b. +1.1 to +2.0 mOhms: -----Minor
  - c. +2.1 to +5.0 mOhms: -----Acceptable
  - d. +5.1 to +15.0 mOhms:-----Marginal
  - e. +15.1 to +1000 mOhms:-----Unstable
  - f.  $>+1000$  mOhms:-----Open Failure

<b>LLCR Measurement Summaries by Pin Type</b>				
Date	2022/9/2	2022/9/5	2022/9/13	2022/9/27
Room Temp (Deg C)	22	22	22	22
Rel Humidity (%)	52	52	52	52
Technician	Kason He	Kason He	Kason He	Kason He
<b>mOhm values</b>	<b>Actual Initial</b>	<b>Delta 100 Cycles</b>	<b>Delta Therm Shck</b>	<b>Delta Humidity</b>
<b>Pin Type 1: Signal</b>				
Average	4.48	0.19	0.53	0.87
St. Dev.	0.14	0.14	0.25	0.30
Min	4.22	0.01	0.10	0.28
Max	4.72	0.56	1.11	1.56
Summary Count	32	32	32	32
Total Count	32	32	32	32

<b>LLCR Delta Count by Category</b>						
mOhms	Stable	Minor	Acceptable	Marginal	Unstable	Open
	$\leq 1$	$>1 \ \& \ \leq 2$	$>2 \ \& \ \leq 5$	$>5 \ \& \ \leq 15$	$>15 \ \& \ \leq 1000$	$>1000$
<b>100 Cycles</b>	<b>32</b>	<b>0</b>	<b>0</b>	<b>0</b>	<b>0</b>	<b>0</b>
<b>Therm Shck</b>	<b>30</b>	<b>2</b>	<b>0</b>	<b>0</b>	<b>0</b>	<b>0</b>
<b>Humidity</b>	<b>23</b>	<b>9</b>	<b>0</b>	<b>0</b>	<b>0</b>	<b>0</b>

**DATA SUMMARIES Continued**

**LLCR Shock &Vibration:**

- 1) A total of 32 points were measured.
- 2) EIA-364-23, *Low Level Contact Resistance Test Procedure for Electrical Connectors and Sockets*.
- 3) A computer program, *LLCR 221.exe*, ensures repeatability for data acquisition.
- 4) The following guidelines are used to categorize the changes in LLCR as a result from stressing.
  - a.  $\leq +1.0$  mOhms:-----Stable
  - b.  $+1.1$  to  $+2.0$  mOhms: -----Minor
  - c.  $+2.1$  to  $+5.0$  mOhms: -----Acceptable
  - d.  $+5.1$  to  $+15.0$  mOhms: -----Marginal
  - e.  $+15.1$  to  $+1000$  mOhms:-----Unstable
  - f.  $>+1000$  mOhms:-----Open Failure

LLCR Measurement Summaries by Pin Type				
Date	2022/10/5	2022/10/13		
Room Temp (Deg C)	22	22		
Rel Humidity (%)	40	39		
Technician	Austin Alley	Austin Alley		
mOhm values	Actual	<b>Delta</b>		
	<b>Initial</b>	<b>Shock-Vib</b>		
Pin Type: Signal 1				
Average	11.13	0.5		
St. Dev.	0.05	0.13		
Min	11.01	0.14		
Max	11.33	0.79		
Summary Count	32	32		
Total Count	32	32		

LLCR Delta Count by Category						
	Stable	Minor	Acceptable	Marginal	Unstable	Open
mOhms	$\leq 1$	$>1 \ \& \ \leq 2$	$>2 \ \& \ \leq 5$	$>5 \ \& \ \leq 15$	$>15 \ \& \ \leq 1000$	$>1000$
Shock-Vib	32	0	0	0	0	0

**Nanosecond Event Detection:**

Shock and Vibration Event Detection Summary	
Contacts tested	60
Test Condition	C, 100g's, 6ms, Half-Sine
Shock Events	0
Test Condition	V-B, 7.56 rms g
Vibration Events	0
<b>Total Events</b>	<b>0</b>

**EQUIPMENT AND CALIBRATION SCHEDULES****Equipment #:** HZ-TCT-01**Description:** Normal force analyzer**Manufacturer:** Mecmesin Multitester**Model:** Mecmesin Multitester 2.5-i**Serial #:** 08-1049-04**Accuracy:** Last Cal: 3/5/2022, Next Cal: 3/4/2023**Equipment #:** DG-THC-01**Description:** Humidity transmitter**Manufacturer:** Thermtron**Model:** SM-8-8200**Serial #:** 50613**Accuracy:** Last Cal: 12/4/2021, Next Cal: 12/3/2022**Equipment #:** HZ-TSC-01**Description:** Vertical Thermal Shock Chamber**Manufacturer:** Cincinnatti Sub Zero**Model:** VTS-3-6-6-SC/AC**Serial #:** 10-VT14994**Accuracy:** See Manual

... Last Cal: 04/16/2022, Next Cal: 04/15/2023

**Equipment #:** HZ-OV-01**Description:** Oven**Manufacturer:** Huida**Model:** CS101-1E**Serial #:** CS101-1E-B**Accuracy:** Last Cal: 12/12/2021, Next Cal: 12/11/2022**Equipment #:** DG-HPT-01**Description:** Hipot Safety Tester**Manufacturer:** Vitrek**Model:** V73**Serial #:** 025866**Accuracy:**

... Last Cal: 04/16/2022, Next Cal: 04/15/2023

**Equipment #:** HZ-MO-05**Description:** Micro-ohmmeter**Manufacturer:** Keithley**Model:** 3706**Serial #:** 1285188**Accuracy:** Last Cal: 1/2/2022, Next Cal: 1/1/2023**Equipment #:** HZ-MO-01**Description:** Micro-ohmmeter**Manufacturer:** Keithley**Model:** 2700**Serial #:** 1199807**Accuracy:** Last Cal: 05/19/2022, Next Cal: 05/18/2023

**EQUIPMENT AND CALIBRATION SCHEDULES Continued****Equipment #:** HZ-PS-01**Description:** Power Supply**Manufacturer:** Agilent**Model:** 6031A**Serial #:** MY41000982**Accuracy:** Last Cal: 04/16/2022, Next Cal: 04/15/2023**Equipment #:** HZ-MO-01**Description:** Micro-ohmmeter**Manufacturer:** Keithley**Model:** 2700**Serial #:** 1199807**Accuracy:** Last Cal: 03/27/2022, Next Cal: 03/26/2023**Equipment #:** HZ-PS-01**Description:** Power Supply**Manufacturer:** Agilent**Model:** 6031A**Serial #:** MY41000982**Accuracy:** Last Cal: 03/27/2022, Next Cal: 04/26/2023**Equipment #:** ACLM-01**Description:** Accelerometer**Manufacturer:** PCB Piezotronics**Model:** 352C03**Serial #:** 115819**Accuracy:** See Manual

... Last Cal: 07/18/2022, Next Cal: 07/18/2023

**Equipment #:** ED-03**Description:** Event Detector**Manufacturer:** Analysis Tech**Model:** 32EHD**Serial #:** 1100604**Accuracy:** See Manual

... Last Cal: 10/31/2022, Next Cal: 10/31/2023

**Equipment #:** MO-04**Description:** Multimeter /Data Acquisition System**Manufacturer:** Keithley**Model:** 2700**Serial #:** 0798688**Accuracy:** See Manual

... Last Cal: 09/11/2022, Next Cal: 09/11/2023