

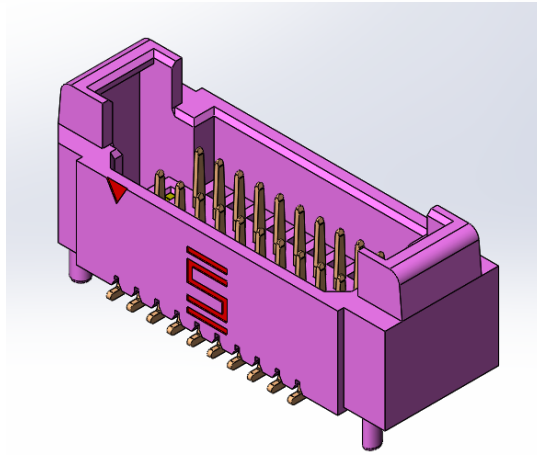

Project Number: Design Qualification Test Report	Tracking Code: 430061_Report_Rev_1
Requested by: Leo Lee	Date: 1/26/2015
Part #: S1SD-10-28-GF-06.00-L1/T1M-10-GF-DV	Tech: Peter Chen
Part description: S1SD/T1M	Qty to test: 95
Test Start: 11/10/2014	Test Completed: 12/15/2014

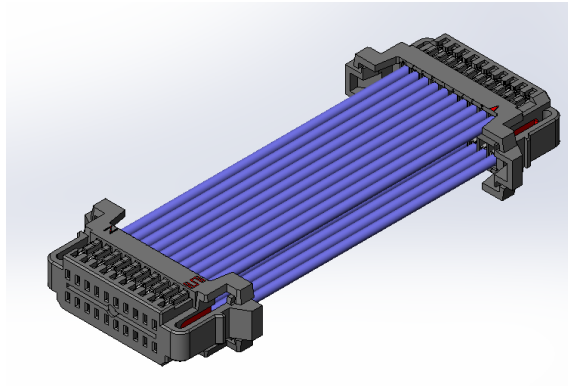

## DESIGN QUALIFICATION TEST REPORT

**S1SD/T1M**

**S1SD-10-28-GF-06.00-L1/T1M-10-GF-DV**

Tracking Code: 430061_Report_Rev_1	Part #: S1SD-10-28-GF-06.00-L1/T1M-10-GF-DV
Part description: S1SD/T1M	

**REVISION HISTORY**

<b>DATA</b>	<b>REV.NUM.</b>	<b>DESCRIPTION</b>	<b>ENG</b>
1/19/2015	1	Initial Issue	PC

## CERTIFICATION

All instruments and measuring equipment were calibrated to National Institute for Standards and Technology (NIST) traceable standards according to ISO 10012-1 and ANSI/NCSL 2540-1, as applicable.

All contents contained herein are the property of Samtec. No portion of this report, in part or in full shall be reproduced without prior written approval of Samtec.

### SCOPE

To perform the following tests: Design Qualification test. Please see test plan.

### APPLICABLE DOCUMENTS

Standards: EIA Publication 364

### TEST SAMPLES AND PREPARATION

- 1) All materials were manufactured in accordance with the applicable product specification.
- 2) All test samples were identified and encoded to maintain traceability throughout the test sequences.
- 3) After soldering, the parts to be used for LLCR and DWV/IR testing were cleaned according to TLWI-0001.
- 4) Either an automated cleaning procedure or an ultrasonic cleaning procedure may be used.
- 5) The automated procedure is used with aqueous compatible soldering materials.
- 6) Parts not intended for testing LLCR and DWV/IR are visually inspected and cleaned if necessary.
- 7) Any additional preparation will be noted in the individual test sequences.
- 8) Solder Information: Lead free
- 9) Samtec Test PCBs used: PCB-106094-TST/ PCB-106095-TST/PCB-106096-TST.

**FLOWCHARTS****Gas Tight**

Group 1  
 S1SD-10-28-GF-06.00-L1  
 T1M-10-GF-DV  
 8 Assemblies

**Step Description**

1. LLCR<sup>(2)</sup>  
Max Delta = 15 mOhm
2. Gas Tight<sup>(1)</sup>
3. LLCR<sup>(2)</sup>  
Max Delta = 15 mOhm

(1) Gas Tight = EIA-364-36

(2) LLCR = EIA-364-23

Open Circuit Voltage = 20 mV Max  
 Test Current = 100 mA Max

**Thermal Aging**

Group 1  
 S1SD-10-28-GF-06.00-L1  
 T1M-10-GF-DV  
 8 Assemblies

*Note: Latches removed*

**Step Description**

1. Contact Gaps
2. Mating/Unmating Force<sup>(2)</sup>
3. Thermal Age<sup>(3)</sup>
4. Mating/Unmating Force<sup>(2)</sup>
5. Contact Gaps

Group 2  
 S1SD-10-28-GF-06.00-L1  
 T1M-10-GF-DV  
 8 Assemblies

**Step Description**

1. Contact Gaps
2. LLCR<sup>(1)</sup>  
Max Delta = 15 mOhm
3. Thermal Age<sup>(3)</sup>
4. LLCR<sup>(1)</sup>  
Max Delta = 15 mOhm
5. Contact Gaps

(1) LLCR = EIA-364-23

Open Circuit Voltage = 20 mV Max  
 Test Current = 100 mA Max

(2) Mating/Unmating Force = EIA-364-13

(3) Thermal Age = EIA-364-17

Test Condition = 4 (105°C)  
 Time Condition = B (250 Hours)

## FLOWCHARTS Continued

### Mating/Unmating/Durability

#### Group 1

S1SD-10-28-GF-06.00-L1  
T1M-10-GF-DV  
8 Assemblies

*Note: Latches removed*

Step	Description
1.	Contact Gaps
2.	Mating/Unmating Force <sup>(3)</sup>
3.	Cycles Quantity = 25 Cycles
4.	Mating/Unmating Force <sup>(3)</sup>
5.	Contact Gaps
6.	Thermal Shock <sup>(4)</sup>
7.	Humidity <sup>(1)</sup>
8.	Mating/Unmating Force <sup>(3)</sup>

#### Group 2

S1SD-02-28-GF-06.00-L1  
T1M-02-GF-DV  
8 Assemblies

*Note: Latches removed*

Step	Description
1.	Contact Gaps
2.	Mating/Unmating Force <sup>(3)</sup>
3.	Cycles Quantity = 25 Cycles
4.	Mating/Unmating Force <sup>(3)</sup>

#### Group 3

S1SD-05-28-GF-06.00-L1  
T1M-05-GF-DV  
8 Assemblies

*Note: Latches removed*

Step	Description
1.	Contact Gaps
2.	Mating/Unmating Force <sup>(3)</sup>
3.	Cycles Quantity = 25 Cycles
4.	Mating/Unmating Force <sup>(3)</sup>

#### Group 4

S1SD-10-28-GF-06.00-L1  
T1M-10-GF-DV  
8 Assemblies

Step	Description
1.	Contact Gaps
2.	LLCR <sup>(2)</sup> Max Delta = 15 mOhm
3.	Cycles Quantity = 25 Cycles
4.	Contact Gaps
5.	LLCR <sup>(2)</sup> Max Delta = 15 mOhm
6.	Thermal Shock <sup>(4)</sup>
7.	LLCR <sup>(2)</sup> Max Delta = 15 mOhm
8.	Humidity <sup>(1)</sup>
9.	LLCR <sup>(2)</sup> Max Delta = 15 mOhm

(1) Humidity = EIA-364-31

Test Condition = B (240 Hours)

Test Method = III (+25°C to +65°C @ 90% RH to 98% RH)

Test Exceptions: ambient pre-condition and delete steps 7a and 7b

(2) LLCR = EIA-364-23

Open Circuit Voltage = 20 mV Max

Test Current = 100 mA Max

(3) Mating/Unmating Force = EIA-364-13

(4) Thermal Shock = EIA-364-32

Exposure Time at Temperature Extremes = 1/2 Hour

Method A, Test Condition = I (-55°C to +85°C)

Test Duration = A-3 (100 Cycles)

**FLOWCHARTS Continued****IR/DWV****Pin-to-Pin**

<u>Group 1</u>		<u>Group 2</u>		<u>Group 3</u>		<u>Group 4</u>	
S1SD-10-28-GF-06.00-L1 T1M-10-GF-DV 2 Assemblies		S1SD-10-28-GF-06.00-L1  2 Assemblies		T1M-10-GF-DV 2 Assemblies		S1SD-10-28-GF-06.00-L1 T1M-10-GF-DV 2 Assemblies	
Step	Description	Step	Description	Step	Description	Step	Description
1.	DWV Breakdown (2)	1.	DWV Breakdown (2)	1.	DWV Breakdown (2)	1.	IR (4)
						2.	DWV at Test Voltage (1)
						3.	Thermal Shock (5)
						4.	IR (4)
						5.	DWV at Test Voltage (1)
						6.	Humidity (3)
						7.	IR (4)
						8.	DWV at Test Voltage (1)

**Row-to-Row**

<u>Group 5</u>		<u>Group 6</u>		<u>Group 7</u>		<u>Group 8</u>	
S1SD-10-28-GF-06.00-L1 T1M-10-GF-DV 2 Assemblies		S1SD-10-28-GF-06.00-L1  2 Assemblies		T1M-10-GF-DV 2 Assemblies		S1SD-10-28-GF-06.00-L1 T1M-10-GF-DV 2 Assemblies	
Step	Description	Step	Description	Step	Description	Step	Description
1.	DWV Breakdown (2)	1.	DWV Breakdown (2)	1.	DWV Breakdown (2)	1.	IR (4)
						2.	DWV at Test Voltage (1)
						3.	Thermal Shock (5)
						4.	IR (4)
						5.	DWV at Test Voltage (1)
						6.	Humidity (3)
						7.	IR (4)
						8.	DWV at Test Voltage (1)

- (1) DWV at Test Voltage = EIA-364-20  
Test Condition = 1 (Sea Level)  
DWV test voltage is equal to 75% of the lowest breakdown voltage  
Test voltage applied for 60 seconds
- (2) DWV Breakdown = EIA-364-20  
Test Condition = 1 (Sea Level)  
DWV test voltage is equal to 75% of the lowest breakdown voltage  
Test voltage applied for 60 seconds
- (3) Humidity = EIA-364-31  
Test Condition = B (240 Hours)  
Test Method = III (+25°C to +65°C @ 90% RH to 98% RH)  
Test Exceptions: ambient pre-condition and delete steps 7a and 7b
- (4) IR = EIA-364-21  
Test Condition = 500 Vdc, 2 Minutes Max
- (5) Thermal Shock = EIA-364-32  
Exposure Time at Temperature Extremes = 1/2 Hour  
Method A, Test Condition = I (-55°C to +85°C)  
Test Duration = A-3 (100 Cycles)

**FLOWCHARTS Continued****Current Carrying Capacity**Group 1

S1SD-10-28-GF-06.00-L1  
T1M-10-GF-DV  
2 Pins Powered  
Signal

Step	Description
1.	CCC <sup>(1)</sup> Rows = 2 Number of Positions = 1

Group 2

S1SD-10-28-GF-06.00-L1  
T1M-10-GF-DV  
4 Pins Powered  
Signal

Step	Description
1.	CCC <sup>(1)</sup> Rows = 2 Number of Positions = 2

Group 3

S1SD-10-28-GF-06.00-L1  
T1M-10-GF-DV  
6 Pins Powered  
Signal

Step	Description
1.	CCC <sup>(1)</sup> Rows = 2 Number of Positions = 3

Group 4

S1SD-10-28-GF-06.00-L1  
T1M-10-GF-DV  
8 Pins Powered  
Signal

Step	Description
1.	CCC <sup>(1)</sup> Rows = 2 Number of Positions = 4

Group 5

S1SD-10-28-GF-06.00-L1  
T1M-10-GF-DV  
20 Pins Powered  
Signal

Step	Description
1.	CCC <sup>(1)</sup> Rows = 2 Number of Positions = 10

(1) CCC = EIA-364-70

Method 2, Temperature Rise Versus Current Curve

(TIN PLATING) - Tabulate calculated current at RT, 65°C, 75°C and 95°C after derating 20% and based on 105°C

(GOLD PLATING) - Tabulate calculated current at RT, 85°C, 95°C and 115°C after derating 20% and based on 125°C

**Mechanical Shock/Random Vibration/LLCR**Group 1

S1SD-10-28-GF-16.00-L1  
T1M-10-GF-DV  
8 Assemblies

Step	Description
1.	LLCR <sup>(1)</sup> Max Delta = 15 mOhm
2.	Mechanical Shock <sup>(2)</sup>
3.	Random Vibration <sup>(3)</sup>
4.	LLCR <sup>(1)</sup> Max Delta = 15 mOhm

(1) LLCR = EIA-364-23

Open Circuit Voltage = 20 mV Max

Test Current = 100 mA Max

(2) Mechanical Shock = EIA-364-27

Test Condition = C (100 G Peak, 6 milliseconds, Half Sine)

Number of Shocks = 3 Per Direction, Per Axis, 18 Total

(3) Random Vibration = EIA-364-28

Condition = VB (7.56 gRMS Average, 2 Hours/Axis)

**FLOWCHARTS Continued****Mechanical Shock/Random Vibration/Event Detection**Group 1

S1SD-10-28-GF-16.00-L1

T1M-10-GF-DV

60 Points

**Step Description**

1. Nanosecond Event Detection  
(Mechanical Shock) (1)
2. Nanosecond Event Detection  
(Random Vibration) (2)

**(1) Nanosecond Event Detection (Mechanical Shock)**

Use EIA-364-87 for Nanosecond Event Detection:

Test Condition = F (50 nanoseconds at 10 ohms)

Use EIA-364-27 for Mechanical Shock:

Test Condition = C (100 G Peak, 6 milliseconds, Half Sine)

Number of Shocks = 3 Per Direction, Per Axis, 18 Total

**(2) Nanosecond Event Detection (Random Vibration)**

Use EIA-364-87 for Nanosecond Event Detection:

Test Condition = F (50 nanoseconds at 10 ohms)

Use EIA-364-28 for Random Vibration:

Condition = VB (7.56 gRMS Average, 2 Hours/Axis)

**Cable Pull**Group 1

S1SD-10-28-GF-18.00-L1

T1M-10-GF-DV

5 Assemblies

0 Degrees

Group 2

S1SD-10-28-GF-18.00-L1

T1M-10-GF-DV

5 Assemblies

90 Degrees

Group 3

S1SD-10-28-GF-18.00-L1

T1M-10-GF-DV

5 Assemblies

90 Degrees Transverse

**Step Description**

1. Cable Pull (1)

**Step Description**

1. Cable Pull (1)

**Step Description**

1. Cable Pull (1)

**(1) Cable Pull = EIA-364-38**

Measure and Record Force Required to Failure

Failure = Discontinuity &gt;1 microsecond at 10 ohms

**FLOWCHARTS Continued****Cable Flex**Group 1

S1SD-10-28-GF-18.00-L1

T1M-10-GF-DV

8 Assemblies

Flat Cable

*Note: Use test voltage from IR/DWV sequence*

Step	Description
1.	IR <sup>(3)</sup>
2.	DWV at Test Voltage <sup>(2)</sup>
3.	Cable Flex <sup>(1)</sup>
4.	Visual Inspection
5.	IR <sup>(3)</sup>
6.	DWV at Test Voltage <sup>(2)</sup>

**(1) Cable Flex = EIA-364-41**

Circular Jacket Cable - to be tested 90° each direction (180° total)

Flat Cable - to be tested 70° each direction (140° total)

Monitor continuity during flex testing

Failure = Discontinuity &gt;1 microsecond at 10 ohms

**(2) DWV at Test Voltage = EIA-364-20**

Test Condition = 1 (Sea Level)

DWV test voltage is equal to 75% of the lowest breakdown voltage

Test voltage applied for 60 seconds

**(3) IR = EIA-364-21**

Test Condition = 500 Vdc, 2 Minutes Max

## ATTRIBUTE DEFINITIONS

The following is a brief, simplified description of attributes.

### THERMAL SHOCK:

- 1) EIA-364-32, *Thermal Shock (Temperature Cycling) Test Procedure for Electrical Connectors*.
- 2) Test Condition 1: -55°C to +85°C
- 3) Test Time: ½ hour dwell at each temperature extreme
- 4) Number of Cycles: 100
- 5) All test samples are pre-conditioned at ambient.
- 6) All test samples are exposed to environmental stressing in the mated condition.

### THERMAL:

- 1) EIA-364-17, *Temperature Life with or without Electrical Load Test Procedure for Electrical Connectors*.
- 2) Test Condition 4 at 105° C
- 3) Test Time Condition B for 250 hours.
- 4) All test samples are pre-conditioned at ambient.
- 5) All test samples are exposed to environmental stressing in the mated condition.

### HUMIDITY:

- 1) Reference document: EIA-364-31, *Humidity Test Procedure for Electrical Connectors*.
- 2) Test Condition B, 240 Hours.
- 3) Method III, +25° C to + 65° C, 90% to 98% Relative Humidity excluding sub-cycles 7a and 7b.
- 4) All samples are pre-conditioned at ambient.
- 5) All test samples are exposed to environmental stressing in the mated condition.

### MATING/UNMATING:

- 1) Reference document: EIA-364-13, *Mating and Unmating Forces Test Procedure for Electrical Connectors*.
- 2) The full insertion position was to within 0.003” to 0.004” of the plug bottoming out in the receptacle to prevent damage to the system under test.
- 3) One of the mating parts is secured to a floating X-Y table to prevent damage during cycling.

### MECHANICAL SHOCK (Specified Pulse):

- 1) Reference document: EIA-364-27, *Mechanical Shock Test Procedure for Electrical Connectors*
- 2) Test Condition C
- 3) Peak Value: 100 G
- 4) Duration: 6 Milliseconds
- 5) Wave Form: Half Sine
- 6) Velocity: 12.3 ft/s
- 7) Number of Shocks: 3 Shocks / Direction, 3 Axis (18 Total)

### VIBRATION:

- 1) Reference document: EIA-364-28, *Vibration Test Procedure for Electrical Connectors*
- 2) Test Condition V, Letter B
- 3) Power Spectral Density: 0.04 G<sup>2</sup> / Hz
- 4) G ‘RMS’: 7.56
- 5) Frequency: 50 to 2000 Hz
- 6) Duration: 2.0 Hours per axis (3 axis total)

### NANOSECOND-EVENT DETECTION:

- 1) Reference document: EIA-364-87, *Nanosecond-Event Detection for Electrical Connectors*
- 2) Prior to test, the samples were characterized to assure the low nanosecond event being monitored will trigger the detector.
- 3) After characterization it was determined the test samples could be monitored for 50 nanosecond events

**ATTRIBUTE DEFINITIONS Continued**

The following is a brief, simplified description of attributes.

**TEMPERATURE RISE (Current Carrying Capacity, CCC):**

- 1) EIA-364-70, *Temperature Rise versus Current Test Procedure for Electrical Connectors and Sockets*.
- 2) When current passes through a contact, the temperature of the contact increases as a result of  $I^2R$  (resistive) heating.
- 3) The number of contacts being investigated plays a significant part in power dissipation and therefore temperature rise.
- 4) The size of the temperature probe can affect the measured temperature.
- 5) Copper traces on PC boards will contribute to temperature rise:
  - a. Self heating (resistive)
  - b. Reduction in heat sink capacity affecting the heated contacts
- 6) A de-rating curve, usually 20%, is calculated.
- 7) Calculated de-rated currents at four temperature points are reported:
  - a. Ambient
  - b. 40° C
  - c. 50° C
  - d. 70° C
- 8) Typically, neighboring contacts (in close proximity to maximize heat build up) are energized.
- 9) The thermocouple (or temperature measuring probe) will be positioned at a location to sense the maximum temperature in the vicinity of the heat generation area.
- 10) A computer program, *TR 803.exe*, ensures accurate stability for data acquisition.
- 11) Hook-up wire cross section is larger than the cross section of any connector leads/PC board traces, jumpers, etc.
- 12) Hook-up wire length is longer than the minimum specified in the referencing standard.

**LLCR:**

- 1) EIA-364-23, *Low Level Contact Resistance Test Procedure for Electrical Connectors and Sockets*.
- 2) A computer program, *LLCR 221.exe*, ensures repeatability for data acquisition.
- 3) The following guidelines are used to categorize the changes in LLCR as a result from stressing
  - a.  $\leq +5.0$  mOhms:----- Stable
  - b.  $+5.1$  to  $+10.0$  mOhms:----- Minor
  - c.  $+10.1$  to  $+15.0$  mOhms:----- Acceptable
  - d.  $+15.1$  to  $+50.0$  mOhms:----- Marginal
  - e.  $+50.1$  to  $+2000$  mOhms:----- Unstable
  - f.  $>+2000$  mOhms:----- Open Failure

### ATTRIBUTE DEFINITIONS Continued

The following is a brief, simplified description of attributes.

#### GAS TIGHT:

To provide method for evaluating the ability of the contacting surfaces in preventing penetration of harsh vapors which might lead to oxide formation that may degrade the electrical performance of the contact system.

- 1) EIA-364-23, *Low Level Contact Resistance Test Procedure for Electrical Connectors and Sockets*.
- 2) A computer program, *LLCR 221.exe*, ensures repeatability for data acquisition.
- 3) The following guidelines are used to categorize the changes in LLCR as a result from stressing
  - a.  $\leq +5.0$  mOhms:----- Stable
  - b.  $+5.1$  to  $+10.0$  mOhms:----- Minor
  - c.  $+10.1$  to  $+15.0$  mOhms:----- Acceptable
  - d.  $+15.1$  to  $+50.0$  mOhms:----- Marginal
  - e.  $+50.1$  to  $+2000$  mOhms:----- Unstable
  - f.  $>+2000$  mOhms:----- Open Failure
- 4) Procedure:
  - a. Reference document: EIA-364-36, *Test Procedure for Determination of Gas-Tight Characteristics for Electrical Connectors, Sockets and/or Contact Systems*.
  - b. Test Conditions:
    - i. Class II--- Mated pairs of contacts assembled to their plastic housings.
    - ii. Reagent grade Nitric Acid shall be used of sufficient volume to saturate the test chamber
    - iii. The ratio of the volume of the test chamber to the surface area of the acid shall be 10:1.
    - iv. The chamber shall be saturated with the vapor for at least 15 minutes before samples are added.
    - v. Exposure time, 55 to 65 minutes.
    - vi. The samples shall be no closer to the chamber walls than 1 inches and no closer to the surface of the acid than 3 inches.
    - vii. The samples shall be dried after exposure for a minimum of 1 hour.
    - viii. Drying temperature  $50^{\circ}$  C
    - ix. The final LLCR shall be conducted within 1 hour after drying.

**ATTRIBUTE DEFINITIONS Continued**

The following is a brief, simplified description of attributes

**INSULATION RESISTANCE (IR):**

To determine the resistance of insulation materials to leakage of current through or on the surface of these materials when a DC potential is applied.

- 1) PROCEDURE:
  - a. Reference document: EIA-364-21, *Insulation Resistance Test Procedure for Electrical Connectors*.
  - b. Test Conditions:
    - i. Between Adjacent Contacts or Signal-to-Ground
    - ii. Electrification Time 2.0 minutes
    - iii. Test Voltage (500 VDC) corresponds to calibration settings for measuring resistances.
- 2) MEASUREMENTS:
- 3) When the specified test voltage is applied (VDC), the insulation resistance shall not be less than 1000 megohms.

**DIELECTRIC WITHSTANDING VOLTAGE (DWV):**

To determine if the sockets can operate at its rated voltage and withstand momentary over potentials due to switching, surges, and other similar phenomenon. Separate samples are used to evaluate the effect of environmental stresses so not to influence the readings from arcing that occurs during the measurement process.

- 1) PROCEDURE:
  - a. Reference document: EIA-364-20, *Withstanding Voltage Test Procedure for Electrical Connectors*.
  - b. Test Conditions:
    - i. Between Adjacent Contacts or Signal-to-Ground
    - ii. Barometric Test Condition 1
    - iii. Rate of Application 500 V/Sec
    - iv. Test Voltage (VAC) until breakdown occurs
- 2) MEASUREMENTS/CALCULATIONS
  - a. The breakdown voltage shall be measured and recorded.
  - b. The dielectric withstanding voltage shall be recorded as 75% of the minimum breakdown voltage.
  - c. The working voltage shall be recorded as one-third (1/3) of the dielectric withstanding voltage (one-fourth of the breakdown voltage).

**ATTRIBUTE DEFINITIONS Continued**

The following is a brief, simplified description of attributes.

**CONNECTOR PULL:**

- 1) Secure cable near center and pull on connector
  - a. At 90°, right angle to cable
  - b. At 0°, in-line with cable



Fig. 1

90° Connector pull, notice the electrical continuity hook-up wires.

**ATTRIBUTE DEFINITIONS Continued**

The following is a brief, simplified description of attributes.

**CABLE DURABILITY:**

- 1) Oscillate and monitor electrical continuity for open circuit indication.
  - a.  $\pm 70^\circ$  Pendulum Mode, bend up to 500 cycles with 16 oz. load on cable end.



Fig. 2

## RESULTS

### Temperature Rise, CCC at a 20% de-rating

- CCC for a 30°C Temperature Rise-----2.5 A per contact with 2 contacts (2x1) powered
- CCC for a 30°C Temperature Rise-----2.0 A per contact with 4 contacts (2x2) powered
- CCC for a 30°C Temperature Rise-----1.6 A per contact with 6 contacts (2x3) powered
- CCC for a 30°C Temperature Rise-----1.5 A per contact with 8 contacts (2x4) powered
- CCC for a 30°C Temperature Rise-----1.2 A per contact with 20 contacts (2x10) powered

### Mating – Unmating Forces

#### Thermal Aging Group (S1SD-10-28-GF-06.00-L1/T1M-10-GF-DV)

- **Initial**
  - **Mating**
    - Min ----- 2.46 Lbs
    - Max----- 3.12 Lbs
  - **Unmating**
    - Min ----- 1.42 Lbs
    - Max----- 2.39 Lbs
- **After Thermal**
  - **Mating**
    - Min ----- 1.65 Lbs
    - Max----- 2.02 Lbs
  - **Unmating**
    - Min ----- 1.35 Lbs
    - Max----- 1.69 Lbs

### Mating – Unmating Forces

#### Mating-Unmating Durability Group (S1SD-10-28-GF-06.00-L1/T1M-10-GF-DV)

- **Initial**
  - **Mating**
    - Min ----- 2.67 Lbs
    - Max----- 3.31 Lbs
  - **Unmating**
    - Min ----- 1.41 Lbs
    - Max----- 2.86 Lbs
- **After 25 Cycles**
  - **Mating**
    - Min ----- 2.52 Lbs
    - Max----- 3.13 Lbs
  - **Unmating**
    - Min ----- 1.62 Lbs
    - Max----- 2.65 Lbs
- **Humidity**
  - **Mating**
    - Min ----- 1.66 Lbs
    - Max----- 1.98 Lbs
  - **Unmating**
    - Min ----- 1.43 Lbs
    - Max----- 1.82 Lbs

**RESULTS Continued****Mating – Unmating Forces****Mating-Unmating Basic (S1SD-05-28-GF-06.00-L1/T1M-05-GF-DV)**

- **Initial**
  - **Mating**
    - **Min** ----- 1.17 Lbs
    - **Max** ----- 1.67 Lbs
  - **Unmating**
    - **Min** ----- 0.69 Lbs
    - **Max** ----- 0.86 Lbs
- **After 25 Cycles**
  - **Mating**
    - **Min** ----- 1.19 Lbs
    - **Max** ----- 1.45 Lbs
  - **Unmating**
    - **Min** ----- 0.92 Lbs
    - **Max** ----- 1.12 Lbs

**Mating-Unmating Basic (S1SD-02-28-GF-06.00-L1/T1M-02-GF-DV)**

- **Initial**
  - **Mating**
    - **Min** ----- 0.45 Lbs
    - **Max** ----- 0.79 Lbs
  - **Unmating**
    - **Min** ----- 0.28 Lbs
    - **Max** ----- 0.37 Lbs
- **After 25 Cycles**
  - **Mating**
    - **Min** ----- 0.44 Lbs
    - **Max** ----- 0.68 Lbs
  - **Unmating**
    - **Min** ----- 0.34 Lbs
    - **Max** ----- 0.44 Lbs

**Cable pull force**

- **0° Pull**
  - **Min** ----- 8.37 Lbs
  - **Max** ----- 9.82 Lbs
- **90° Pull**
  - **Min** ----- 10.76 Lbs
  - **Max** ----- 13.44 Lbs
- **90° Pull (Transverse)**
  - **Min** ----- 5.20 Lbs
  - **Max** ----- 6.94 Lbs

**RESULTS Continued****Insulation Resistance minimums, IR****Pin to Pin**

- **Initial**
  - Mated-----10000 Meg  $\Omega$  ----- Passed
  - Unmated -----10000 Meg  $\Omega$  ----- Passed
- **Thermal Shock**
  - Mated-----10000 Meg  $\Omega$  ----- Passed
  - Unmated -----10000 Meg  $\Omega$  ----- Passed
- **Humidity**
  - Mated-----10000 Meg  $\Omega$  ----- Passed
  - Unmated -----10000 Meg  $\Omega$  ----- Passed

**Row to Row**

- **Initial**
  - Mated-----10000 Meg  $\Omega$  ----- Passed
  - Unmated -----10000 Meg  $\Omega$  ----- Passed
- **Thermal Shock**
  - Mated-----10000 Meg  $\Omega$  ----- Passed
  - Unmated -----10000 Meg  $\Omega$  ----- Passed
- **Humidity**
  - Mated-----10000 Meg  $\Omega$  ----- Passed
  - Unmated -----10000 Meg  $\Omega$  ----- Passed

**Dielectric Withstanding Voltage minimums, DWV**

- **Minimums**
  - Breakdown Voltage----- 1000 VAC
  - Test Voltage -----750 VAC
  - Working Voltage -----250 VAC

**Pin to Pin**

- **Initial DWV** -----Passed
- **Thermal DWV**-----Passed
- **Humidity DWV**-----Passed

**Row to Row**

- **Initial DWV** -----Passed
- **Thermal DWV**-----Passed
- **Humidity DWV**-----Passed

**RESULTS Continued****CABLE FLEX****Insulation Resistance minimums, IR****Pin to Pin**

- **Initial**
  - Mated-----45000 Meg  $\Omega$  ----- Passed
- **After flex test**
  - Mated-----45000 Meg  $\Omega$  ----- Passed

**Row to Row**

- **Initial**
  - Mated-----45000 Meg  $\Omega$  ----- Passed
- **After flex test**
  - Mated-----45000 Meg  $\Omega$  ----- Passed

**Dielectric Withstanding Voltage minimums, DWV****Pin to Pin**

- **Initial DWV** -----Passed
- **After Flex DWV** -----Passed

**Row to Row**

- **Initial DWV** -----Passed
- **After Flex DWV** -----Passed

**LLCR Thermal Aging Group (128 LLCR test points)**

- **Initial** ----- 29.40 mOhms Max
- **Thermal**
  - **<= +5.0 mOhms** ----- 99 Points ----- Stable
  - **+5.1 to +10.0 mOhms** ----- 29 Points ----- Minor
  - **+10.1 to +15.0 mOhms** ----- 0 Points ----- Acceptable
  - **+15.1 to +50.0 mOhms** ----- 0 Points ----- Marginal
  - **+50.1 to +2000 mOhms** ----- 0 Points ----- Unstable
  - **>+2000 mOhms** ----- 0 Points ----- Open Failure

**LLCR Mating/Unmating Durability Group (128 LLCR test points)**

- **Initial** ----- 30.52 mOhms Max
- **Durability, 25 Cycles**
  - **<= +5.0 mOhms** ----- 122 Points ----- Stable
  - **+5.1 to +10.0 mOhms** ----- 6 Points ----- Minor
  - **+10.1 to +15.0 mOhms** ----- 0 Points ----- Acceptable
  - **+15.1 to +50.0 mOhms** ----- 0 Points ----- Marginal
  - **+50.1 to +2000 mOhms** ----- 0 Points ----- Unstable
  - **>+2000 mOhms** ----- 0 Points ----- Open Failure
- **Thermal Shock**
  - **<= +5.0 mOhms** ----- 113 Points ----- Stable
  - **+5.1 to +10.0 mOhms** ----- 15 Points ----- Minor
  - **+10.1 to +15.0 mOhms** ----- 0 Points ----- Acceptable
  - **+15.1 to +50.0 mOhms** ----- 0 Points ----- Marginal
  - **+50.1 to +2000 mOhms** ----- 0 Points ----- Unstable
  - **>+2000 mOhms** ----- 0 Points ----- Open Failure

**RESULTS Continued**

- **Humidity**

- <= +5.0 mOhms ----- 114 Points ----- Stable
- +5.1 to +10.0 mOhms ----- 14 Points ----- Minor
- +10.1 to +15.0 mOhms ----- 0 Points ----- Acceptable
- +15.1 to +50.0 mOhms ----- 0 Points ----- Marginal
- +50.1 to +2000 mOhms ----- 0 Points ----- Unstable
- >+2000 mOhms ----- 0 Points ----- Open Failure

**LLCR Gas Tight Group (128 LLCR test points)**

- **Initial** ----- 29.75 mOhms Max
- **Gas-Tight**
  - <= +5.0 mOhms ----- 126 Points ----- Stable
  - +5.1 to +10.0 mOhms ----- 2 Points ----- Minor
  - +10.1 to +15.0 mOhms ----- 0 Points ----- Acceptable
  - +15.1 to +50.0 mOhms ----- 0 Points ----- Marginal
  - +50.1 to +2000 mOhms ----- 0 Points ----- Unstable
  - >+2000 mOhms ----- 0 Points ----- Open Failure

**LLCR Shock & Vibration Group (128 LLCR test points)**

- **Initial** ----- 75.93 mOhms Max
- **Shock & Vibration**
  - <= +5.0 mOhms ----- 128 Points ----- Stable
  - +5.1 to +10.0 mOhms ----- 0 Points ----- Minor
  - +10.1 to +15.0 mOhms ----- 0 Points ----- Acceptable
  - +15.1 to +50.0 mOhms ----- 0 Points ----- Marginal
  - +50.1 to +2000 mOhms ----- 0 Points ----- Unstable
  - >+2000 mOhms ----- 0 Points ----- Open Failure

**Mechanical Shock & Random Vibration:**

- **Shock**
  - **No Damage**----- Pass
  - **50 Nanoseconds**----- Pass
- **Vibration**
  - **No Damage**----- Pass
  - **50 Nanoseconds**----- Pass

## DATA SUMMARIES

### TEMPERATURE RISE (Current Carrying Capacity, CCC):

- 1) High quality thermocouples whose temperature slopes track one another were used for temperature monitoring.
- 2) The thermocouples were placed at a location to sense the maximum temperature generated during testing.
- 3) Temperature readings recorded are those for which three successive readings, 15 minutes apart, differ less than 1° C (computer controlled data acquisition).
- 4) Adjacent contacts were powered:
  - a. Linear configuration with 2 adjacent conductors/contacts powered

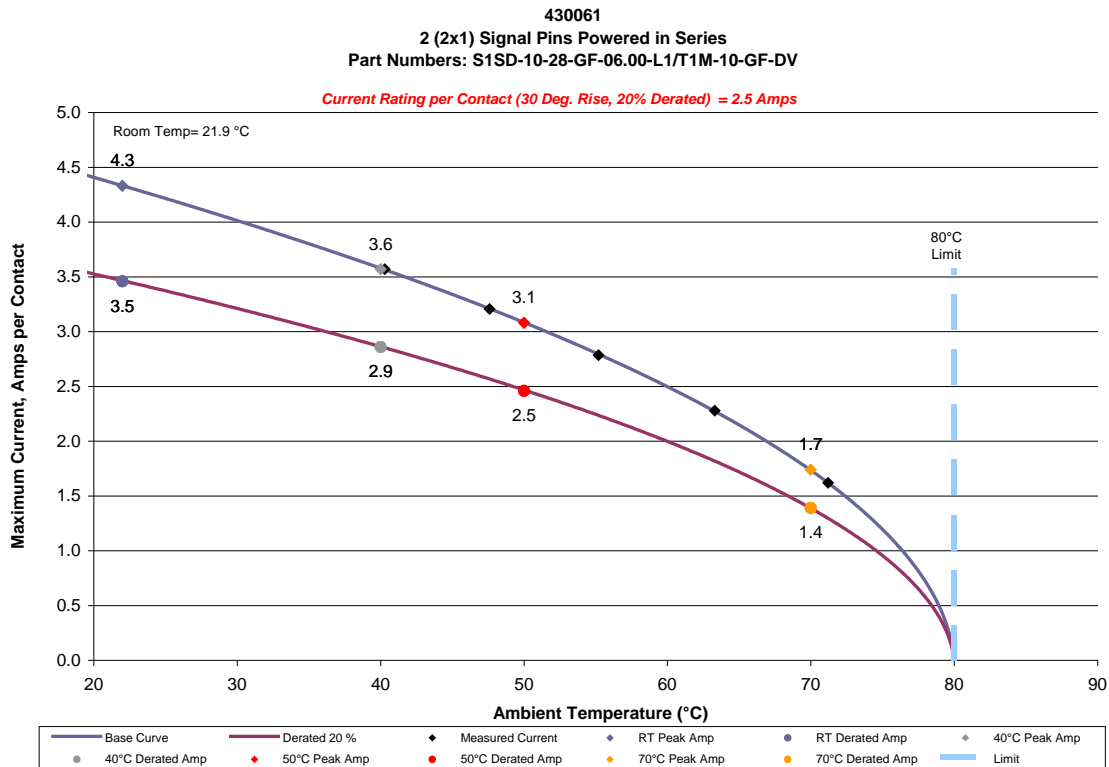

### DATA SUMMARIES Continued

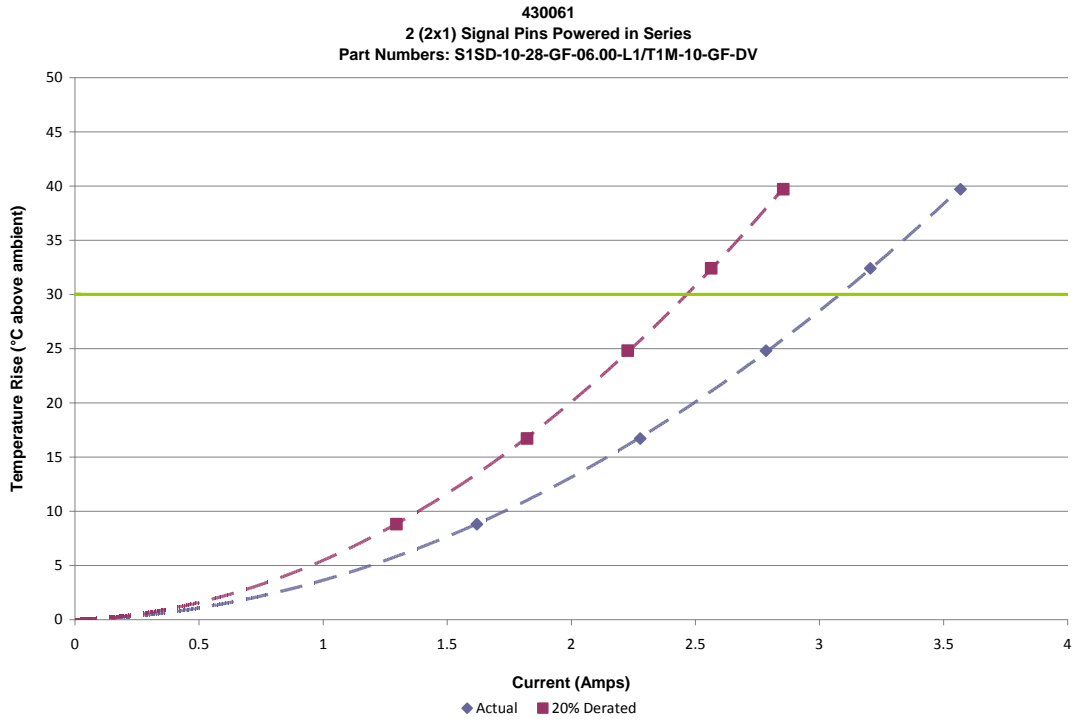

### DATA SUMMARIES Continued

b. Linear configuration with 4 adjacent conductors/contacts powered

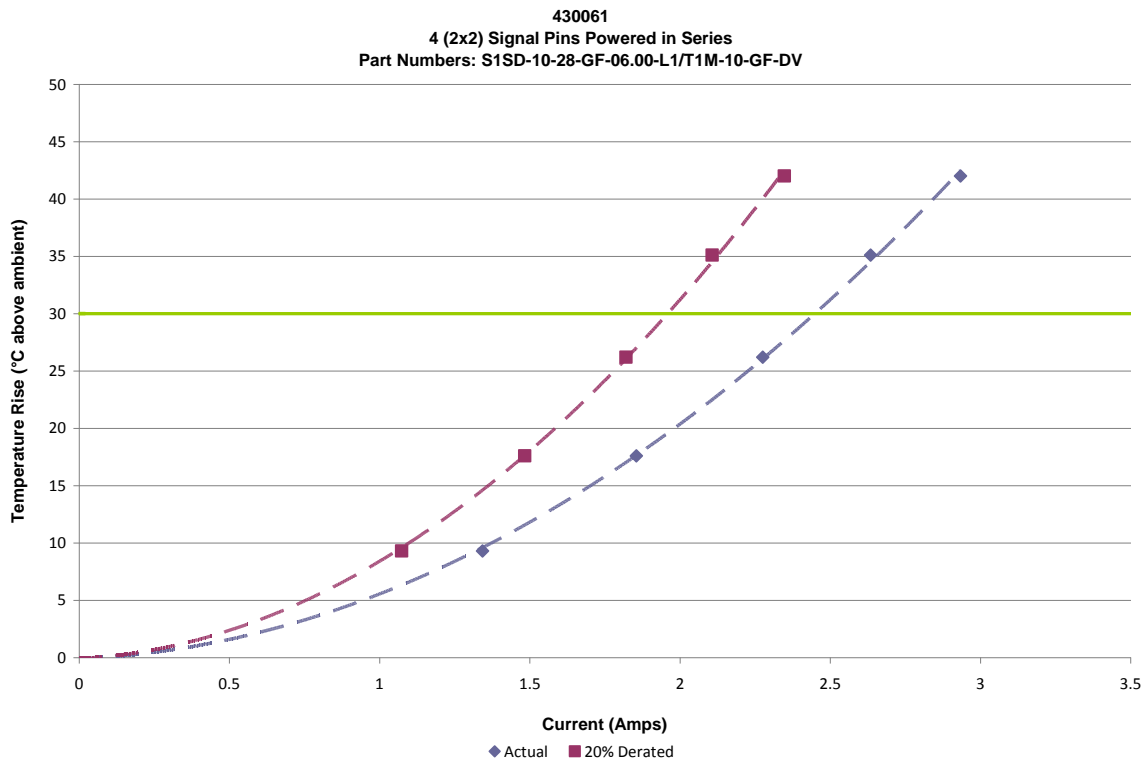
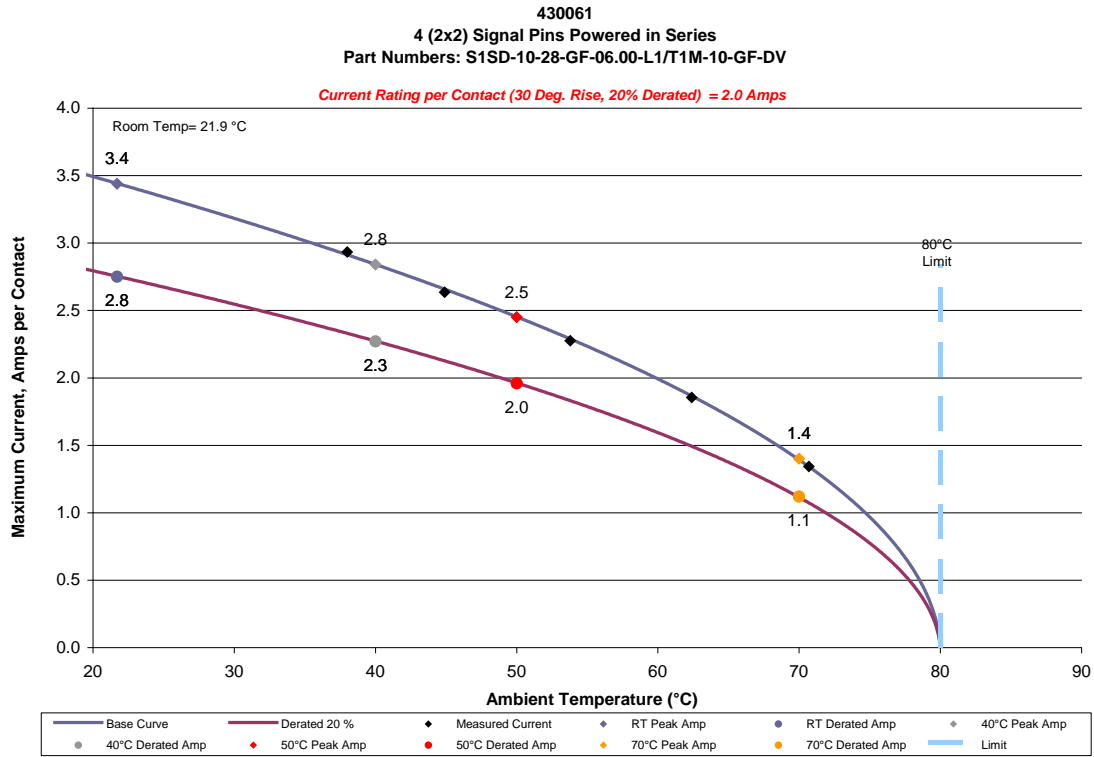

### DATA SUMMARIES Continued

c. Linear configuration with 6 adjacent conductors/contacts powered

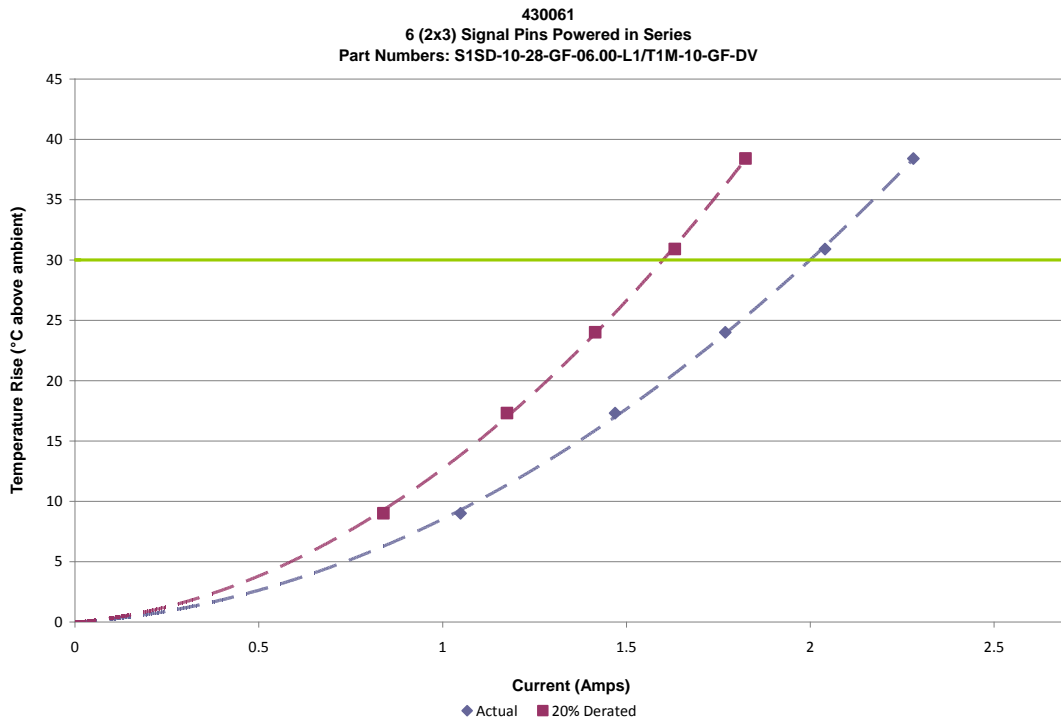
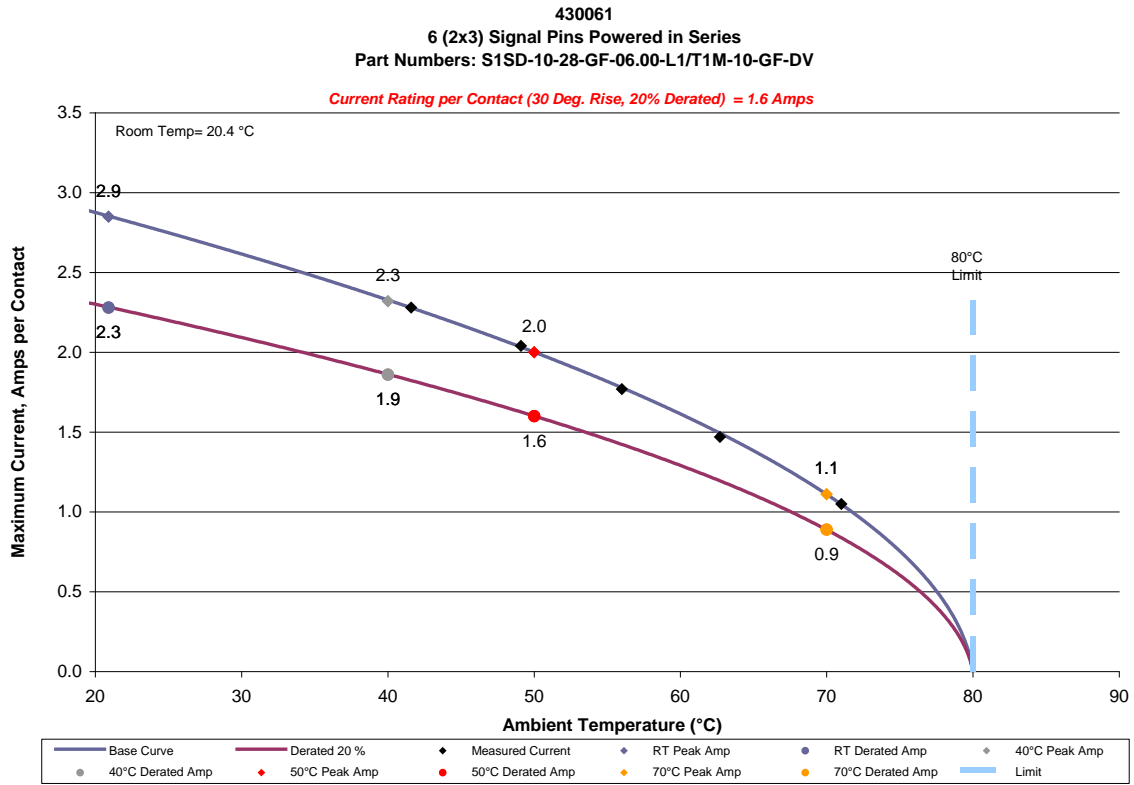

### DATA SUMMARIES Continued

d. Linear configuration with 8 adjacent conductors/contacts powered

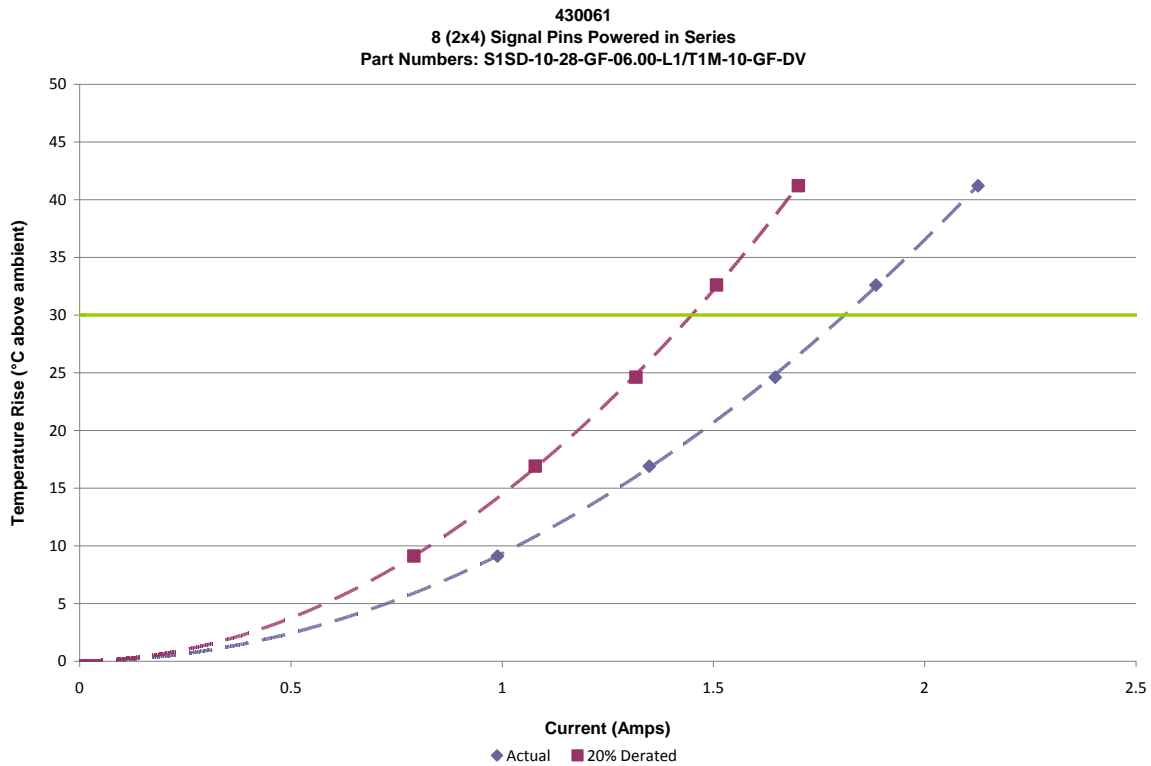
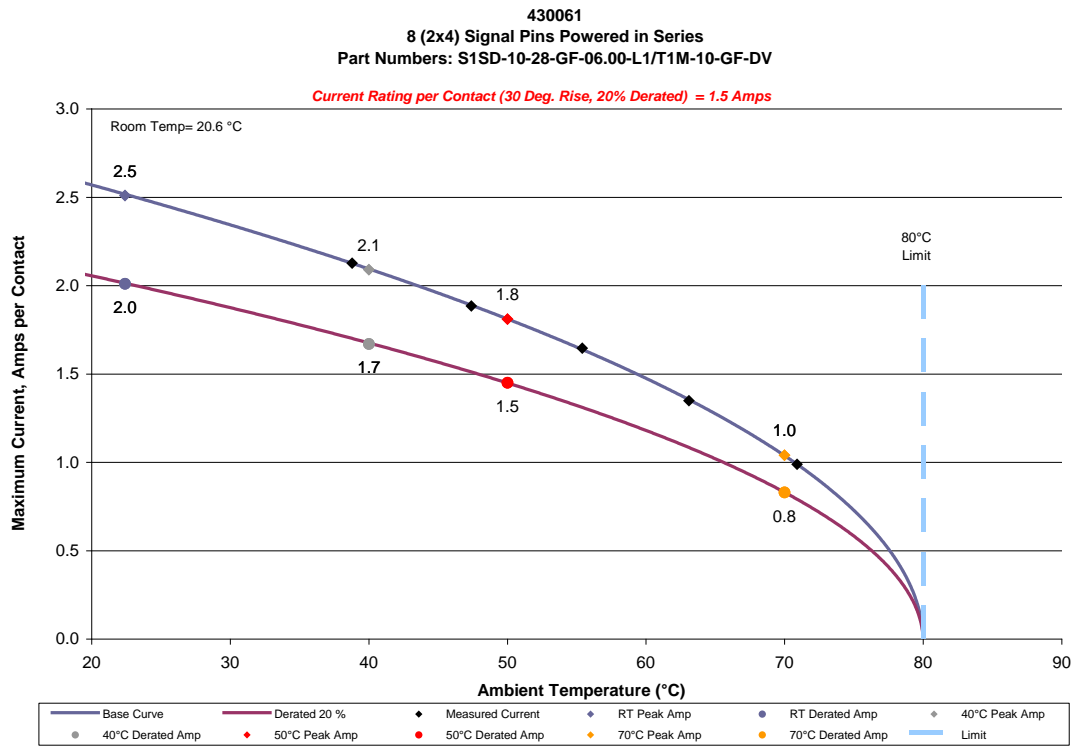

**DATA SUMMARIES Continued**

e. Linear configuration with all adjacent conductors/contacts powered

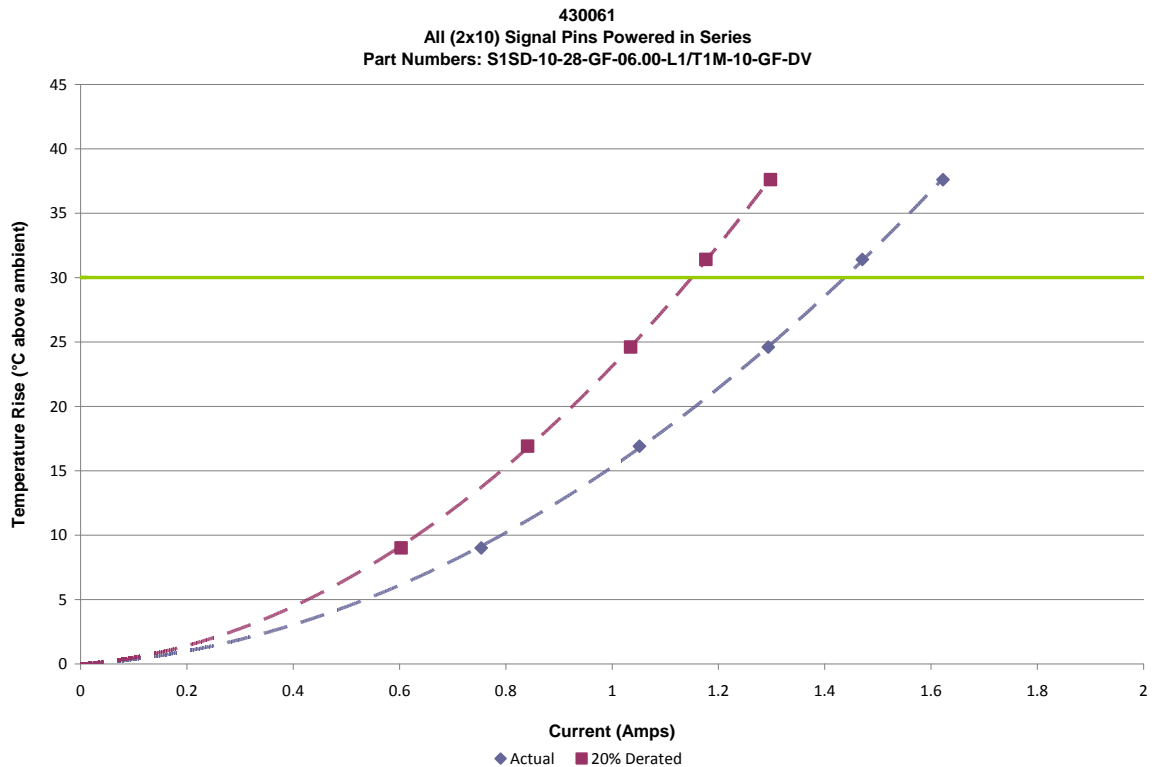
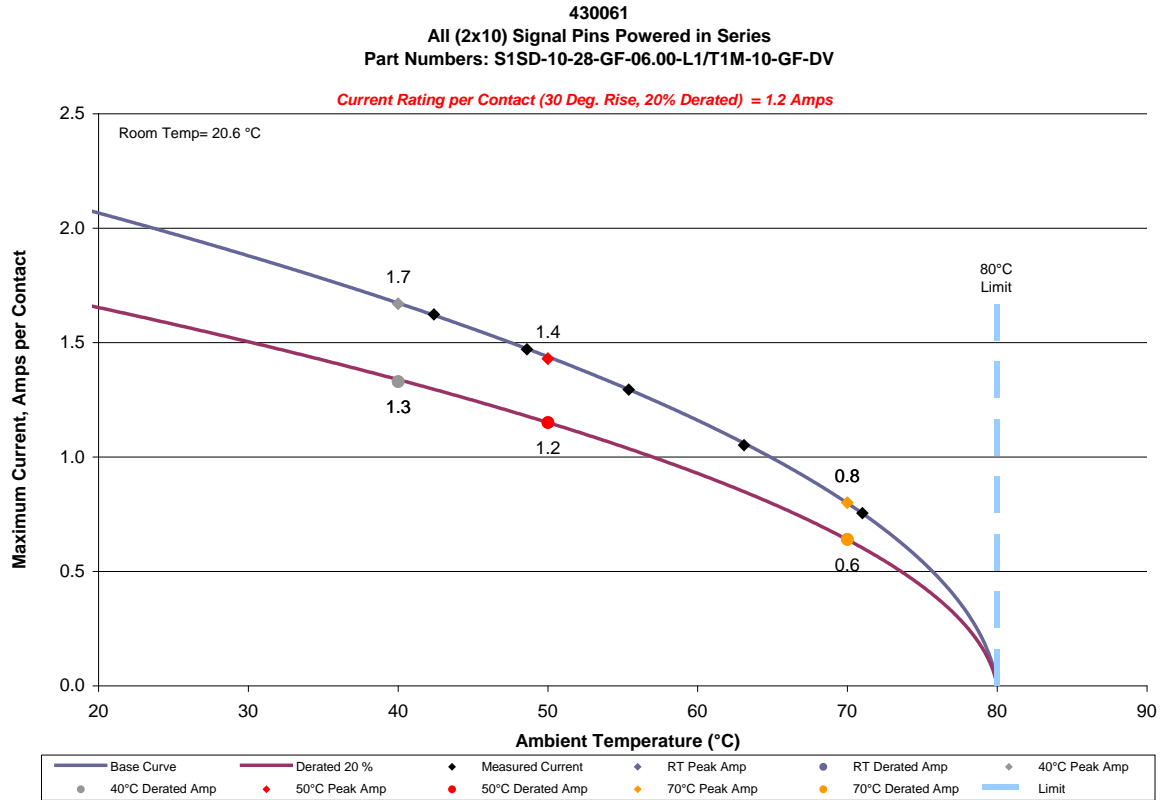

**DATA SUMMARIES Continued****MATING-UNMATING FORCE:****Thermal Aging Group (S1SD-10-28-GF-06.00-L1/T1M-10-GF-DV)**

	Initial				After Thermals			
	Mating		Unmating		Mating		Unmating	
	Newtons	Force (Lbs)	Newtons	Force (Lbs)	Newtons	Force (Lbs)	Newtons	Force (Lbs)
Minimum	10.94	2.46	6.32	1.42	7.34	1.65	6.00	1.35
Maximum	13.88	3.12	10.63	2.39	8.98	2.02	7.52	1.69
<b>Average</b>	12.57	<b>2.83</b>	8.15	<b>1.83</b>	8.09	<b>1.82</b>	6.83	<b>1.54</b>
St Dev	1.01	0.23	1.53	0.34	0.62	0.14	0.54	0.12
Count	8	8	8	8	8	8	8	8

**Mating-Unmating Durability Group (S1SD-10-28-GF-06.00-L1/T1M-10-GF-DV)**

	Initial				25 Cycles			
	Mating		Unmating		Mating		Unmating	
	Newtons	Force (Lbs)	Newtons	Force (Lbs)	Newtons	Force (Lbs)	Newtons	Force (Lbs)
Minimum	11.88	2.67	6.27	1.41	11.21	2.52	7.21	1.62
Maximum	14.72	3.31	12.72	2.86	13.92	3.13	11.79	2.65
<b>Average</b>	13.34	<b>3.00</b>	8.67	<b>1.95</b>	12.58	<b>2.83</b>	8.81	<b>1.98</b>
St Dev	1.28	0.29	2.13	0.48	1.02	0.23	1.48	0.33
Count	8	8	8	8	8	8	8	8

	After Humidity			
	Mating		Unmating	
	Newtons	Force (Lbs)	Newtons	Force (Lbs)
Minimum	7.38	1.66	6.36	1.43
Maximum	8.81	1.98	8.10	1.82
<b>Average</b>	8.10	<b>1.82</b>	7.12	<b>1.60</b>
St Dev	0.50	0.11	0.61	0.14
Count	8	8	8	8

**DATA SUMMARIES Continued****Mating-Unmating Basic (S1SD-05-28-GF-06.00-L1/T1M-05-GF-DV)**

	Initial				25 Cycles			
	Mating		Unmating		Mating		Unmating	
	Newton's	Force (Lbs)	Newton's	Force (Lbs)	Newton's	Force (Lbs)	Newton's	Force (Lbs)
Minimum	5.20	1.17	3.07	0.69	5.29	1.19	4.09	0.92
Maximum	7.43	1.67	3.83	0.86	6.45	1.45	4.98	1.12
<b>Average</b>	5.89	<b>1.32</b>	3.34	<b>0.75</b>	5.79	<b>1.30</b>	4.35	<b>0.98</b>
St Dev	0.69	0.16	0.23	0.05	0.35	0.08	0.28	0.06
Count	8	8	8	8	8	8	8	8

**Mating-Unmating Basic (S1SD-02-28-GF-06.00-L1/T1M-02-GF-DV)**

	Initial				25 Cycles			
	Mating		Unmating		Mating		Unmating	
	Newton's	Force (Lbs)	Newton's	Force (Lbs)	Newton's	Force (Lbs)	Newton's	Force (Lbs)
Minimum	2.00	0.45	1.25	0.28	1.96	0.44	1.51	0.34
Maximum	3.51	0.79	1.65	0.37	3.02	0.68	1.96	0.44
<b>Average</b>	2.55	<b>0.57</b>	1.48	<b>0.33</b>	2.53	<b>0.57</b>	1.81	<b>0.41</b>
St Dev	0.43	0.10	0.14	0.03	0.30	0.07	0.13	0.03
Count	8	8	8	8	8	8	8	8

### DATA SUMMARIES Continued

#### Mating\Unmating Force Comparison

Mating/Unmating Data for 2, 5 and 10 Position S1SD/T1M

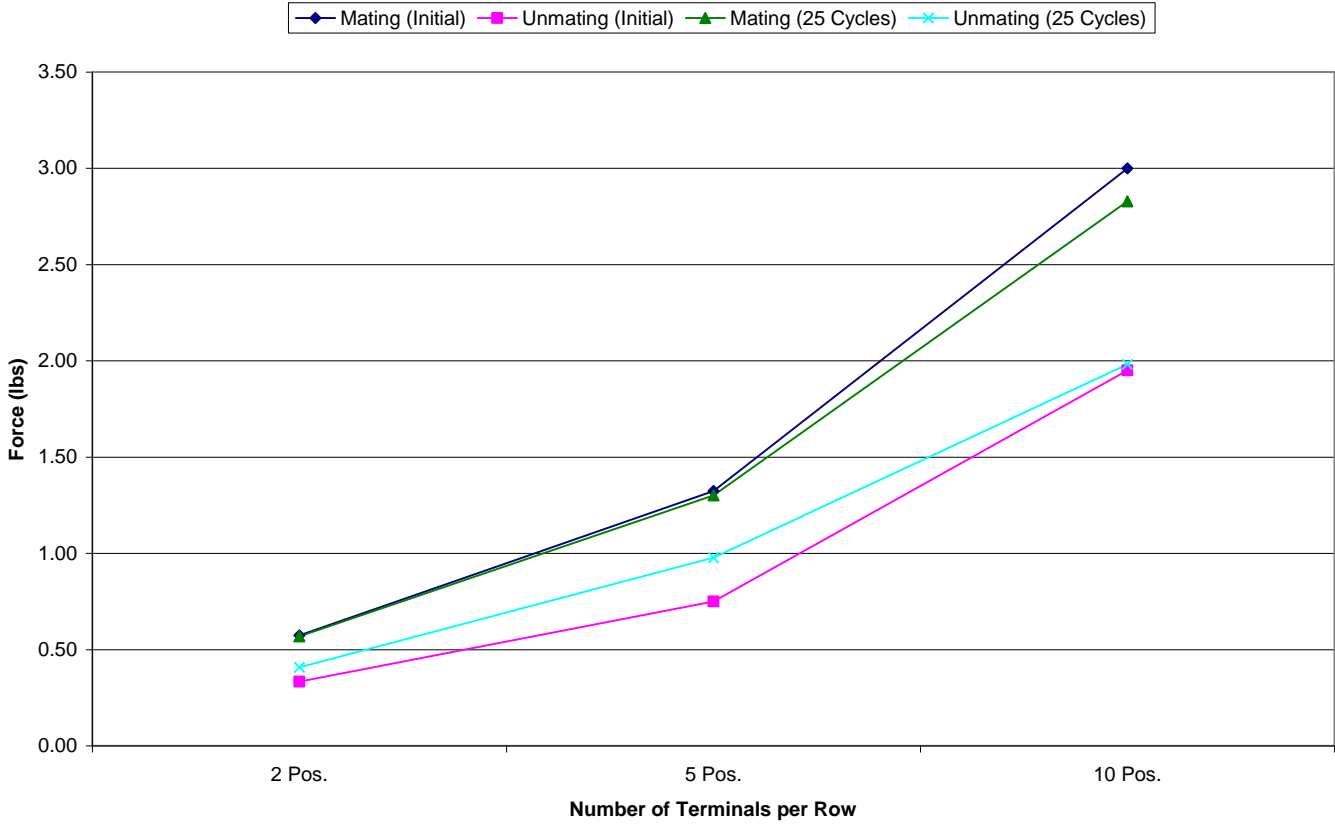

**DATA SUMMARIES Continued****Cable Pull force  
0° Pull**

	Force (lbs)
Minimum	<b>8.37</b>
Maximum	9.82
Average	9.16

**90° Pull**

	Force (lbs)
Minimum	<b>10.76</b>
Maximum	13.44
Average	12.23

**90° Pull (Transverse)**

	Force (lbs)
Minimum	<b>5.20</b>
Maximum	6.94
Average	6.11

**DATA SUMMARIES Continued****INSULATION RESISTANCE (IR):**

Minimum	Pin to Pin		
	Mated	Unmated	Unmated
	<b>S1SD/T1M</b>	<b>S1SD</b>	<b>T1M</b>
<b>Initial</b>	10000	10000	10000
<b>Thermal</b>	10000	10000	10000
<b>Humidity</b>	10000	10000	10000

Minimum	Row to Row		
	Mated	Unmated	Unmated
	<b>S1SD/T1M</b>	<b>S1SD</b>	<b>T1M</b>
<b>Initial</b>	10000	10000	10000
<b>Thermal</b>	10000	10000	10000
<b>Humidity</b>	10000	10000	10000

**DIELECTRIC WITHSTANDING VOLTAGE (DWV):**

Voltage Rating Summary	
Minimum	<b>S1SD/T1M</b>
<b>Break Down Voltage</b>	1000
<b>Test Voltage</b>	750
<b>Working Voltage</b>	250

Pin to Pin	
<b>Initial Test Voltage</b>	Passed
<b>After Thermal Test Voltage</b>	Passed
<b>After Humidity Test Voltage</b>	Passed

Row to Row	
<b>Initial Test Voltage</b>	Passed
<b>After Thermal Test Voltage</b>	Passed
<b>After Humidity Test Voltage</b>	Passed

**DATA SUMMARIES Continued****Cable Flex test****INSULATION RESISTANCE (IR):**

<b>Pin to Pin</b>	
Mated	
Minimum	
<b>Initial</b>	45000
<b>After 500 Flex Cycles</b>	45000

<b>Row to Row</b>	
Mated	
Minimum	
<b>Initial</b>	45000
<b>After 500 Flex Cycles</b>	45000

**DIELECTRIC WITHSTANDING VOLTAGE (DWV):**

<b>Voltage Rating Summary</b>	
<b>Minimum</b>	
<b>Break Down Voltage</b>	1000
<b>Test Voltage</b>	750
<b>Working Voltage</b>	250

<b>Pin to Pin</b>	
<b>Initial Test Voltage</b>	Passed
<b>After 500 Flex Cycles Test Voltage</b>	Passed

<b>Row to Row</b>	
<b>Initial Test Voltage</b>	Passed
<b>After 500 Flex Cycles Test Voltage</b>	Passed

**DATA SUMMARIES Continued****LLCR Thermal Aging Group**

- 1) A total of 192 points were measured.
- 2) EIA-364-23, *Low Level Contact Resistance Test Procedure for Electrical Connectors and Sockets*.
- 3) A computer program, *LLCR 221.exe*, ensures repeatability for data acquisition.
- 4) The following guidelines are used to categorize the changes in LLCR as a result from stressing.
  - a.  $\leq +5.0$  mOhms:-----Stable
  - b.  $+5.1$  to  $+10.0$  mOhms:-----Minor
  - c.  $+10.1$  to  $+15.0$  mOhms:-----Acceptable
  - d.  $+15.1$  to  $+50.0$  mOhms:-----Marginal
  - e.  $+50.1$  to  $+2000$  mOhms-----Unstable
  - f.  $>+2000$  mOhms:-----Open Failure

<b>LLCR Measurement Summaries by Pin Type</b>				
Date	11/21/2014	12/11/2014		
Room Temp (Deg C)	21	22		
Rel Humidity (%)	53	54		
Technician	Peter Chen	Peter Chen		
<b>mOhm values</b>	<b>Actual Initial</b>	<b>Delta Thermal</b>	<b>Delta</b>	<b>Delta</b>
<b>Pin Type 1: Signal</b>				
Average	26.14	3.10		
St. Dev.	1.31	2.19		
Min	23.30	0.02		
Max	29.40	9.51		
Summary Count	128	128		
Total Count	128	128		

<b>LLCR Delta Count by Category</b>						
	<b>Stable</b>	<b>Minor</b>	<b>Acceptable</b>	<b>Marginal</b>	<b>Unstable</b>	<b>Open</b>
<b>mOhms</b>	$\leq 5$	$>5 \ \& \ \leq 10$	$>10 \ \& \ \leq 15$	$>15 \ \& \ \leq 50$	$>50 \ \& \ \leq 1000$	$>1000$
<b>Thermal</b>	99	29	0	0	0	0

**DATA SUMMARIES Continued****LLCR Mating/Unmating Durability Group**

- 1). A total of 192 points were measured.
- 2). EIA-364-23, *Low Level Contact Resistance Test Procedure for Electrical Connectors and Sockets*.
- 3). A computer program, *LLCR 221.exe*, ensures repeatability for data acquisition.
- 4). The following guidelines are used to categorize the changes in LLCR as a result from stressing.
  - a.  $\leq +5.0$  mOhms: ----- Stable
  - b.  $+5.1$  to  $+10.0$  mOhms: ----- Minor
  - c.  $+10.1$  to  $+15.0$  mOhms: ----- Acceptable
  - d.  $+15.1$  to  $+50.0$  mOhms: ----- Marginal
  - e.  $+50.1$  to  $+2000$  mOhms ----- Unstable
  - f.  $> +2000$  mOhms: ----- Open Failure

<b>LLCR Measurement Summaries by Pin Type</b>				
Date	11/20/2014	11/24/2014	12/2/2014	12/15/2014
Room Temp (Deg C)	21	22	21	23
Rel Humidity (%)	54	53	51	49
Technician	Peter Chen	Peter Chen	Peter Chen	Peter Chen
mOhm values	<b>Actual</b>	<b>Delta</b>	<b>Delta Therm Shck</b>	<b>Delta Humidity</b>
	<b>Initial</b>	<b>25 Cycles</b>		
<b>Pin Type 1: Signal</b>				
Average	25.12	2.48	2.70	2.52
St. Dev.	1.38	1.48	1.79	1.92
Min	22.39	0.06	0.00	0.02
Max	30.52	9.15	9.02	9.28
Summary Count	128	128	128	128
Total Count	128	128	128	128

<b>LLCR Delta Count by Category</b>						
mOhms	Stable	Minor	Acceptable	Marginal	Unstable	Open
	$\leq 5$	$>5$ & $\leq 10$	$>10$ & $\leq 15$	$>15$ & $\leq 50$	$>50$ & $\leq 1000$	$>1000$
<b>25 Cycles</b>	122	6	0	0	0	0
<b>Therm Shck</b>	113	15	0	0	0	0
<b>Humidity</b>	114	14	0	0	0	0

**DATA SUMMARIES Continued****LLCR Gas Tight Group**

- 1) A total of 192 points were measured.
- 2) EIA-364-23, *Low Level Contact Resistance Test Procedure for Electrical Connectors and Sockets*.
- 3) A computer program, *LLCR 221.exe*, ensures repeatability for data acquisition.
- 4) The following guidelines are used to categorize the changes in LLCR as a result from stressing.
  - a.  $\leq +5.0$  mOhms: ----- Stable
  - b.  $+5.1$  to  $+10.0$  mOhms: ----- Minor
  - c.  $+10.1$  to  $+15.0$  mOhms: ----- Acceptable
  - d.  $+15.1$  to  $+50.0$  mOhms: ----- Marginal
  - e.  $+50.1$  to  $+2000$  mOhms: ----- Unstable
  - f.  $>+2000$  mOhms: ----- Open Failure

<b>LLCR Measurement Summaries by Pin Type</b>				
Date	11/17/2014	11/20/2014		
Room Temp (Deg C)	23	21		
Rel Humidity (%)	54	54		
Technician	Peter Chen	Peter Chen		
<b>mOhm values</b>	<b>Actual Initial</b>	<b>Delta Acid Vapor</b>	<b>Delta</b>	<b>Delta</b>
<b>Pin Type 1: Signal</b>				
Average	25.59	1.27		
St. Dev.	1.06	1.08		
Min	22.86	0.00		
Max	29.75	5.66		
Summary Count	128	128		
Total Count	128	128		

<b>LLCR Delta Count by Category</b>						
	<b>Stable</b>	<b>Minor</b>	<b>Acceptable</b>	<b>Marginal</b>	<b>Unstable</b>	<b>Open</b>
<b>mOhms</b>	<b><math>\leq 5</math></b>	<b><math>&gt;5</math> &amp; <math>\leq 10</math></b>	<b><math>&gt;10</math> &amp; <math>\leq 15</math></b>	<b><math>&gt;15</math> &amp; <math>\leq 50</math></b>	<b><math>&gt;50</math> &amp; <math>\leq 1000</math></b>	<b><math>&gt;1000</math></b>
<b>Acid Vapor</b>	<b>126</b>	<b>2</b>	<b>0</b>	<b>0</b>	<b>0</b>	<b>0</b>

### DATA SUMMARIES Continued

#### LLCR Shock & Vibration Group

- 1) A total of 192 points were measured.
- 2) EIA-364-23, *Low Level Contact Resistance Test Procedure for Electrical Connectors and Sockets*.
- 3) A computer program, *LLCR 221.exe*, ensures repeatability for data acquisition.
- 4) The following guidelines are used to categorize the changes in LLCR as a result from stressing.
  - a.  $\leq +5.0$  mOhms: ----- Stable
  - b.  $+5.1$  to  $+10.0$  mOhms:----- Minor
  - c.  $+10.1$  to  $+15.0$  mOhms: ----- Acceptable
  - d.  $+15.1$  to  $+50.0$  mOhms: ----- Marginal
  - e.  $+50.1$  to  $+2000$  mOhms ----- Unstable
  - f.  $>+2000$  mOhms: ----- Open Failure

LLCR Measurement Summaries by Pin Type				
Date	12/18/2014	12/23/2014		
Room Temp (Deg C)	22	22		
Rel Humidity (%)	34	39		
Technician	Aaron McKim	Tony Wagoner		
<b>mOhm values</b>	<b>Actual Initial</b>	<b>Delta Shock-Vib</b>	<b>Delta</b>	<b>Delta</b>
Pin Type 1: Signal				
Average	72.99	0.58		
St. Dev.	0.95	0.60		
Min	71.00	0.00		
Max	75.93	3.35		
Summary Count	128	128		
Total Count	128	128		

LLCR Delta Count by Category						
mOhms	Stable	Minor	Acceptable	Marginal	Unstable	Open
	$\leq 5$	$>5 \ \& \ \leq 10$	$>10 \ \& \ \leq 15$	$>15 \ \& \ \leq 50$	$>50 \ \& \ \leq 1000$	$>1000$
<b>Shock-Vib</b>	<b>128</b>	<b>0</b>	<b>0</b>	<b>0</b>	<b>0</b>	<b>0</b>

#### Nanosecond Event Detection:

Shock and Vibration Event Detection Summary	
Contacts tested	60
Test Condition	C, 100g's, 6ms, Half-Sine
Shock Events	0
Test Condition	V-B, 7.56 rms g
Vibration Events	0
Total Events	0

**EQUIPMENT AND CALIBRATION SCHEDULES****Equipment #:** HZ-HPM-01**Description:** IR/DWV Tester**Manufacturer:** AN9636H**Model:** AN9636H**Serial #:** 089601091**Accuracy:** Last Cal: 2014-7-6, Next Cal: 2015-7-5**Equipment #:** HZ-TCT-01**Description:** Normal force analyzer**Manufacturer:** Mecmesin Multitester**Model:** Mecmesin Multitester 2.5-i**Serial #:** 08-1049-04**Accuracy:** Last Cal: 2014-4-28, Next Cal: 2015-4-27**Equipment #:** HZ-OV-01**Description:** Oven**Manufacturer:** Huida**Model:** CS101-1E**Serial #:** CS101-1E-B**Accuracy:** Last Cal: 2013-12-14, Next Cal: 2014-12-13**Equipment #:** HZ-THC-01**Description:** Humidity transmitter**Manufacturer:** Thermtron**Model:** HMM30C**Serial #:** D0240037**Accuracy:** Last Cal: 2014-3-3, Next Cal: 2015-3-2**Equipment #:** HZ-TSC-01**Description:** Thermal Shock transmitter**Manufacturer:** CSZ**Model:** 10-VT14994**Serial #:** VTS-3-6-6-SC/AC**Accuracy:** Last Cal: 2013-11-1, Next Cal: 2014-11-1**Equipment #:** HZ-MO-05**Description:** Micro-ohmmeter**Manufacturer:** Keithley**Model:** 3706**Serial #:** 297288**Accuracy:** Last Cal: 2014-8-6, Next Cal: 2015-8-5

**EQUIPMENT AND CALIBRATION SCHEDULES****Equipment #:** MO-02**Description:** Multimeter /Data Acquisition System**Manufacturer:** Keithley**Model:** 2700**Serial #:** 0780546**Accuracy:** Last Cal: 2014-6-16, Next Cal: 2015-6-16**Equipment #:** PS-01**Description:** Power Supply**Manufacturer:** Hewlett Packard**Model:** 6033A**Serial #:** 3329A-07330**Accuracy:** Last Cal: 2014-6-12, Next Cal: 2015-6-12**Equipment #:** PS-02**Description:** Power Supply**Manufacturer:** Hewlett Packard**Model:** 6033A**Serial #:** 2847A-04167**Accuracy:** Last Cal: 2014-6-12, Next Cal: 2015-6-12**Equipment #:** SVC-01**Description:** Shock & Vibration Table**Manufacturer:** Data Physics**Model:** LE-DSA-10-20K**Serial #:** 10037**Accuracy:** See Manual

... Last Cal: 2013-11-31, Next Cal: 2014-11-31

**Equipment #:** ACLM-01**Description:** Accelerometer**Manufacturer:** PCB Piezotronics**Model:** 352C03**Serial #:** 115819**Accuracy:** See Manual

... Last Cal: 2014-07-9, Next Cal: 2015-7-9

**Equipment #:** ED-03**Description:** Event Detector**Manufacturer:** Analysis Tech**Model:** 32EHD**Serial #:** 1100604**Accuracy:** See Manual

... Last Cal: 2014-06-4, Next Cal: 2015-06-4