

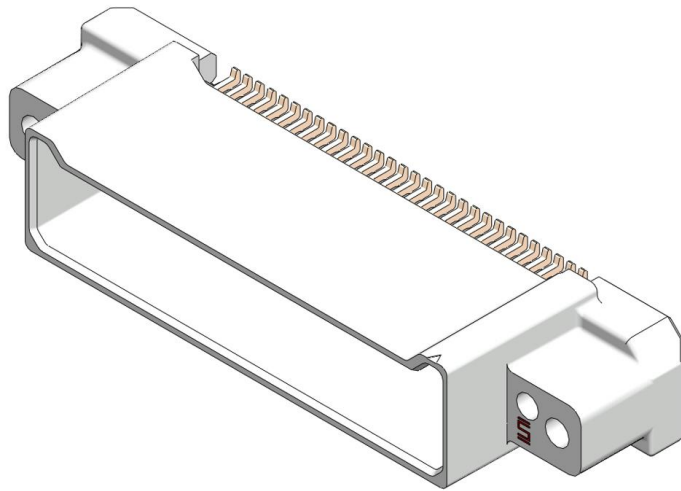

Project Number: Extended Environmental Testing	Tracking Code: CR-1023102_Report_Rev_1
Requested by: Tyler Lang	Date: 5/29/2024
Part #: B1SDT-30-28-H-06.0/P1M-30-01-S-DV-TR	
Part description: B1SDT\P1M	Tech: John Crawford
Test Start: 12/19/2023	Test Completed: 1/16/2024

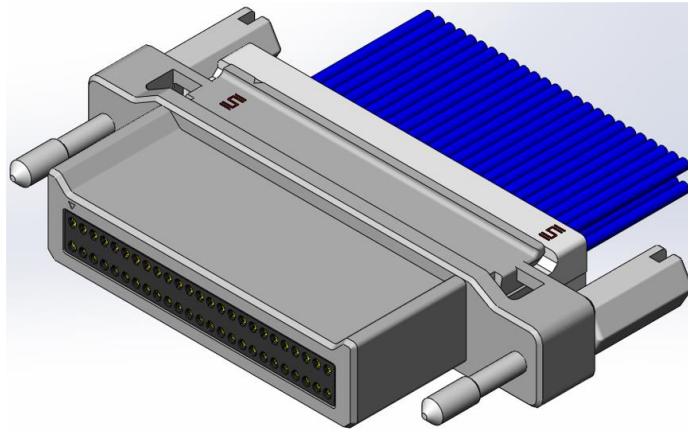

**Extended Environmental Testing  
B1SDT/P1M  
B1SDT-30-28-H-06.0/P1M-30-01-S-DV-TR**

Tracking Code: CR-1023102_Report_Rev_1	Part #: B1SDT-30-28-H-06.0/P1M-30-01-S-DV-TR
Part description: B1SDT\P1M	

**REVISION HISTORY**

<b>DATA</b>	<b>REV.NUM.</b>	<b>DESCRIPTION</b>	<b>ENG</b>
2/28/2024	1	Initial Issue	KH

## CERTIFICATION

All instruments and measuring equipment were calibrated to National Institute for Standards and Technology (NIST) traceable standards according to ISO 10012-1 and ANSI/NCSL 2540-1, as applicable.

All contents contained herein are the property of Samtec. No portion of this report, in part or in full shall be reproduced without prior written approval of Samtec.

### SCOPE

To perform the following tests: Extended Environmental Testing. Please see test plan.

### APPLICABLE DOCUMENTS

Standards: EIA Publication 364, VITA 47.1.

### TEST SAMPLES AND PREPARATION

- 1) All materials were manufactured in accordance with the applicable product specification.
- 2) All test samples were identified and encoded to maintain traceability throughout the test sequences.
- 3) After soldering, the parts to be used for LLCR testing were cleaned according to TLWI-0001.
- 4) Either an automated cleaning procedure or an ultrasonic cleaning procedure may be used.
- 5) The automated procedure is used with aqueous compatible soldering materials.
- 6) Parts not intended for testing LLCR are visually inspected and cleaned if necessary.
- 7) Any additional preparation will be noted in the individual test sequences.
- 8) Solder Information: Lead free.
- 9) Samtec Test PCBs used: PCB-112305-TST.

**FLOWCHARTS****Mechanical Shock/Random Vibration/LLCR**Group 1

B1SDT-30-28-H-12.0

P1M-30-01-S-DV-TR

8 Assemblies

VITA 47.1

Step	Description
1.	LLCR <sup>(1)</sup>
2.	Mechanical Shock <sup>(2)</sup> - Non Standard
3.	Random Vibration <sup>(3)</sup> - Non Standard <i>Note: Conditions:</i> 1) 5 Hz to 100 Hz, PSD increasing at 3dB/octave 2) 100 Hz to 1000 Hz 0.10 g <sup>2</sup> /Hz 3) 1000 Hz to 2000 Hz PSD decreasing at 3dB/octave
4.	LLCR <sup>(1)</sup> Max Delta = 15 mOhm

**(1) LLCR = EIA-364-23**

Open Circuit Voltage = 20 mV Max  
Test Current = 100 mA Max

**(2) Mechanical Shock = Other**

40G, 11 milliseconds, Half Sine  
Number of Shocks = 3 Per Direction, Per Axis, 18 Total  
Operating Shock Class OS2

**(3) Random Vibration = Other**

12 G 'RMS', 5Hz to 2000Hz, 1 Hours/Axis  
Vibration Class V3 VITA 47.1

**Mechanical Shock/Random Vibration/Event Detection**Group 1

B1SDT-30-28-H-12.0

P1M-30-01-S-DV-TR

8 Assemblies

VITA 47.1

Step	Description
1.	Nanosecond Event Detection (Mechanical Shock) <sup>(1)</sup> - Non Standard
2.	Nanosecond Event Detection (Random Vibration) <sup>(2)</sup> - Non Standard <i>Note: Conditions:</i> 1) 5 Hz to 100 Hz, PSD increasing at 3dB/octave 2) 100 Hz to 1000 Hz 0.10 g <sup>2</sup> /Hz 3) 1000 Hz to 2000 Hz PSD decreasing at 3dB/octave

**(1) Nanosecond Event Detection (Mechanical Shock) = Other**

Use EIA-364-87 for Nanosecond Event Detection:  
Test Condition = F (50 nanoseconds at 10 ohms)  
40G, 11 milliseconds, Half Sine

**(2) Nanosecond Event Detection (Random Vibration) = Other**

Use EIA-364-87 for Nanosecond Event Detection:  
Test Condition = F (50 nanoseconds at 10 ohms)  
Random Vibration: 12 G 'RMS', 5Hz to 2000Hz, 1 Hours/Axis, Vibration Class V3 VITA 47.1

### ATTRIBUTE DEFINITIONS

The following is a brief, simplified description of attributes.

#### **MECHANICAL SHOCK (Specified Pulse):**

- 1) Other method, *Mechanical Shock Test Procedure for Electrical Connectors*
- 2) Peak Value: 40 G
- 3) Duration: 11 Milliseconds
- 4) Wave Form: Half Sine
- 5) Velocity: Operating Shock Class OS2
- 6) Number of Shocks: 3 Shocks / Direction, 3 Axis (18 Total)

#### **VIBRATION:**

- 1) Other method, *Vibration Test Procedure for Electrical Connectors*
- 2) G 'RMS': 12
- 3) Frequency: 5 to 2000 Hz.
- 4) Vibration Class V3 VITA 47.1
- 5) Duration: 1 Hour per axis (3 axis total).

#### **NANOSECOND-EVENT DETECTION:**

- 1) Reference document: EIA-364-87, *Nanosecond-Event Detection for Electrical Connectors*
- 2) Prior to test, the samples were characterized to assure the low nanosecond event being monitored will trigger the detector.
- 3) After characterization it was determined the test samples could be monitored for 50 nanosecond events

## RESULTS

### LLCR Shock & Vibration Group (192 LLCR test points)

- **Initial** ----- 68.34 mOhms Max
- **Shock & Vibration**
  - **<= +5.0 mOhms**----- 190 Points ----- Stable
  - **+5.1 to +10.0 mOhms** ----- 2 Points ----- Minor
  - **+10.1 to +15.0 mOhms** ----- 0 Points ----- Acceptable
  - **+15.1 to +50.0 mOhms** ----- 0 Points ----- Marginal
  - **+50.1 to +1000 mOhms**----- 0 Points ----- Unstable
  - **>+1000 mOhms**----- 0 Points ----- Open Failure

### Mechanical Shock & Random Vibration:

- **Shock**
  - **No Damage**----- Pass
  - **50 Nanoseconds** ----- Pass
- **Vibration**
  - **No Damage**----- Pass
  - **50 Nanoseconds** ----- Pass

**DATA SUMMARIES**

**LLCR Shock & Vibration Group**

- 1) A total of 192 points were measured.
- 2) EIA-364-23, *Low Level Contact Resistance Test Procedure for Electrical Connectors and Sockets*.
- 3) A computer program, *LLCR 221.exe*, ensures repeatability for data acquisition.
- 4) The following guidelines are used to categorize the changes in LLCR as a result from stressing.
  - a.  $\leq +5.0$  mOhms:-----Stable
  - b.  $+5.1$  to  $+10.0$  mOhms:-----Minor
  - c.  $+10.1$  to  $+15.0$  mOhms:-----Acceptable
  - d.  $+15.1$  to  $+50.0$  mOhms:-----Marginal
  - e.  $+50.1$  to  $+1000$  mOhms-----Unstable
  - f.  $>+1000$  mOhms:-----Open Failure

LLCR Measurement Summaries by Pin Type			
Date	2023/12/19	2024/1/16	
Room Temp (Deg C)	22	21	
Rel Humidity (%)	25	24	
Technician	John Crawford	John Crawford	
mOhm values	Actual	Delta	
	Initial	Shock-Vib	
Pin Type: Signal 1			
Average	66.91	0.43	
St. Dev.	0.67	0.63	
Min	62.44	0	
Max	68.34	6.42	
Summary Count	192	192	
Total Count	192	192	

LLCR Delta Count by Category						
	Stable	Minor	Acceptable	Marginal	Unstable	Open
mOhms	$\leq 5$	$>5 \ \& \ \leq 10$	$>10 \ \& \ \leq 15$	$>15 \ \& \ \leq 50$	$>50 \ \& \ \leq 1000$	$>1000$
Shock-Vib	190	2	0	0	0	0

**Nanosecond Event Detection:**

Shock and Vibration Event Detection Summary	
Contacts tested	60
Test Condition	Operating Shock Class OS2
Shock Events	0
Test Condition	Vita Class V3 VITA 47.1
Vibration Events	0
Total Events	0

**EQUIPMENT AND CALIBRATION SCHEDULES****Equipment #:** MO-11**Description:** Switch/Multimeter**Manufacturer:** Keithley**Model:** 3706**Serial #:** 120169**Accuracy:** See Manual

... Last Cal: 09/11/2023, Next Cal: 09/11/2024

**Equipment #:** SVC-01**Description:** Shock & Vibration Table**Manufacturer:** Data Physics**Model:** LE-DSA-10-20K**Serial #:** 10037**Accuracy:** See Manual

... Last Cal: 04/22/2023, Next Cal: 04/22/2024

**Equipment #:** ACLM-01**Description:** Accelerometer**Manufacturer:** PCB Piezotronics**Model:** 352C03**Serial #:** 115819**Accuracy:** See Manual

... Last Cal: 07/18/2023, Next Cal: 07/18/2024

**Equipment #:** ED-03**Description:** Event Detector**Manufacturer:** Analysis Tech**Model:** 32EHD**Serial #:** 1100604**Accuracy:** See Manual

... Last Cal: 10/31/2023, Next Cal: 10/31/2024