

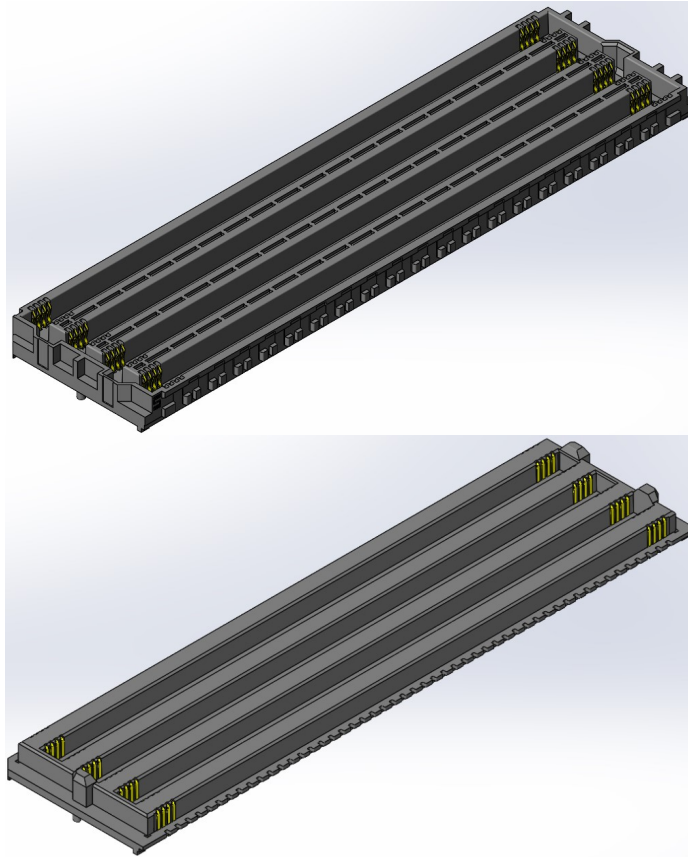

Project Number: Design Qualification Test Report	Tracking Code: CR-1088502_Report_Rev_1
Requested by: Jacob Harris	Date: 2/8/2025
Part #: APF6-100-03.5-S-08-0-A-TR/APM6-100-01.5-S-08-0-A-TR	
Part description: APF6/APM6	Tech: Brian Stemle
Test Start: 6/3/2024	Test Completed: 7/3/2024



**DESIGN QUALIFICATION TEST REPORT**  
**APF6/APM6**  
**APF6-100-03.5-S-08-0-A-TR/APM6-100-01.5-S-08-0-A-TR**

Tracking Code: CR-1088502_Report_Rev_1	Part #: APF6-100-03.5-S-08-0-A-TR/APM6-100-01.5-S-08-0-A-TR
Part description: APF6/APM6	

### REVISION HISTORY

DATA	REV.NUM.	DESCRIPTION	ENG
2/8/2025	1	Initial test	KH

## CERTIFICATION

All instruments and measuring equipment were calibrated to National Institute for Standards and Technology (NIST) traceable standards according to ISO 10012-1 and ANSI/NCSL 2540-1, as applicable.

All contents contained herein are the property of Samtec. No portion of this report, in part or in full shall be reproduced without prior written approval of Samtec.

### SCOPE

To perform the following tests: Design Qualification test. Please see test plan.

### APPLICABLE DOCUMENTS

Standards: EIA Publication 364

### TEST SAMPLES AND PREPARATION

- 1) All materials were manufactured in accordance with the applicable product specification.
- 2) All test samples were identified and encoded to maintain traceability throughout the test sequences.
- 3) After soldering, the parts to be used for LLCR and DWV/IR testing were cleaned according to CO-SC-WI-3029.
- 4) Either an automated cleaning procedure or an ultrasonic cleaning procedure may be used.
- 5) The automated procedure is used with aqueous compatible soldering materials.
- 6) Parts not intended for testing LLCR and DWV/IR are visually inspected and cleaned if necessary.
- 7) Any additional preparation will be noted in the individual test sequences.
- 8) Solder Information: Lead Free
- 9) Samtec Test PCBs used: PCB-113634-TST-XX, PCB-113639-TST-XX, PCB-113648-TST-XX,  
PCB-113672-TST-XX.

## FLOWCHARTS

### Thermal Aging

#### Group 1

APF6-100-03.5-S-08-0-A-TR

APM6-100-01.5-S-08-0-A-TR

4 Assemblies

---

Step	Description
1.	LLCR <sup>(1)</sup>
2.	Thermal Age <sup>(2)</sup>
3.	LLCR <sup>(1)</sup> Max Delta = 15 mOhm

---

(1) LLCR = EIA-364-23

Open Circuit Voltage = 20 mV Max

Test Current = 100 mA Max

(2) Thermal Age = EIA-364-17

Test Condition = 4 (105°C)

Time Condition = B (250 Hours)

**FLOWCHARTS Continued****Mating/Unmating/Durability**Group 1

APF6-100-03.5-S-08-0-A-TR

APM6-100-01.5-S-08-0-A-TR

8 Assemblies

Step	Description
1.	Contact Gaps
2.	LLCR (2)
3.	Mating/Unmating Force (3)
4.	Cycles Quantity = 25 Cycles
5.	Mating/Unmating Force (3)
6.	Contact Gaps
7.	LLCR (2) Max Delta = 15 mOhm
8.	Thermal Shock (4)
9.	LLCR (2) Max Delta = 15 mOhm
10.	Humidity (1)
11.	LLCR (2) Max Delta = 15 mOhm
12.	Mating/Unmating Force (3)

(1) Humidity = EIA-364-31

Test Condition = B (240 Hours)

Test Method = III (+25°C to +65°C @ 90% RH to 98% RH)

Test Exceptions: ambient pre-condition and delete steps 7a and 7b

(2) LLCR = EIA-364-23

Open Circuit Voltage = 20 mV Max

Test Current = 100 mA Max

(3) Mating/Unmating Force = EIA-364-13

(4) Thermal Shock = EIA-364-32

Exposure Time at Temperature Extremes = 1/2 Hour

Method A, Test Condition = I (-55°C to +85°C)

Test Duration = A-3 (100 Cycles)

**Mating/Unmating/Durability**Group 1

APF6-100-03.5-S-08-0-A-TR

APM6-100-01.5-S-08-0-A-TR

8 Assemblies

Step	Description
1.	Contact Gaps
2.	Mating/Unmating Force (1)
3.	Cycles Quantity = 25 Cycles
4.	Mating/Unmating Force (1)

(1) Mating/Unmating Force = EIA-364-13

**FLOWCHARTS Continued****Current Carrying Capacity**Group 1

APF6-100-03.5-S-08-0-A-TR  
 APM6-100-01.5-S-08-0-A-TR  
 8 Pins Powered  
 Signal

Step	Description
1.	CCC <sup>(1)</sup> Rows = 8 Number of Positions = 1

Group 2

APF6-100-03.5-S-08-0-A-TR  
 APM6-100-01.5-S-08-0-A-TR  
 16 Pins Powered  
 Signal

Step	Description
1.	CCC <sup>(1)</sup> Rows = 8 Number of Positions = 2

Group 3

APF6-100-03.5-S-08-0-A-TR  
 APM6-100-01.5-S-08-0-A-TR  
 24 Pins Powered  
 Signal

Step	Description
1.	CCC <sup>(1)</sup> Rows = 8 Number of Positions = 3

Group 4

APF6-100-03.5-S-08-0-A-TR  
 APM6-100-01.5-S-08-0-A-TR  
 32 Pins Powered  
 Signal

Step	Description
1.	CCC <sup>(1)</sup> Rows = 8 Number of Positions = 4

Group 5

APF6-100-03.5-S-08-0-A-TR  
 APM6-100-01.5-S-08-0-A-TR  
 800 Pins Powered  
 Signal

Step	Description
1.	CCC <sup>(1)</sup> Rows = 8 Number of Positions = 100

(1) CCC = EIA-364-70

Method 2, Temperature Rise Versus Current Curve

(TIN PLATING) - Tabulate calculated current at RT, 65°C, 75°C and 95°C after derating 20% and based on 105°C

(GOLD PLATING) - Tabulate calculated current at RT, 85°C, 95°C and 115°C after derating 20% and based on 125°C

**FLOWCHARTS Continued****Mechanical Shock/Random Vibration/LLCR**Group 1

APF6-100-03.5-S-08-0-A-TR

APM6-100-01.5-S-08-0-A-TR

8 Assemblies

**Step Description**

1. LLCR <sup>(1)</sup>
2. Mechanical Shock <sup>(2)</sup>
3. Random Vibration <sup>(3)</sup>
4. LLCR <sup>(1)</sup>  
Max Delta = 15 mOhm

**(1) LLCR = EIA-364-23**

Open Circuit Voltage = 20 mV Max  
Test Current = 100 mA Max

**(2) Mechanical Shock = EIA-364-27**

Test Condition = C (100 G Peak, 6 milliseconds, Half Sine)  
Number of Shocks = 3 Per Direction, Per Axis, 18 Total

**(3) Random Vibration = EIA-364-28**

Condition = VB (7.56 gRMS Average, 2 Hours/Axis)

**Mechanical Shock/Random Vibration/Event Detection**Group 1

APF6-100-03.5-S-08-0-A-TR

APM6-100-01.5-S-08-0-A-TR

60 Points

**Step Description**

1. Nanosecond Event Detection  
(Mechanical Shock) <sup>(1)</sup>
2. Nanosecond Event Detection  
(Random Vibration) <sup>(2)</sup>

**(1) Nanosecond Event Detection (Mechanical Shock)**

Use EIA-364-87 for Nanosecond Event Detection:

Test Condition = F (50 nanoseconds at 10 ohms)

Use EIA-364-27 for Mechanical Shock:

Test Condition = C (100 G Peak, 6 milliseconds, Half Sine)

Number of Shocks = 3 Per Direction, Per Axis, 18 Total

**(2) Nanosecond Event Detection (Random Vibration)**

Use EIA-364-87 for Nanosecond Event Detection:

Test Condition = F (50 nanoseconds at 10 ohms)

Use EIA-364-28 for Random Vibration:

Condition = VB (7.56 gRMS Average, 2 Hours/Axis)

## ATTRIBUTE DEFINITIONS

The following is a brief, simplified description of attributes.

### THERMAL:

- 1) EIA-364-17, *Temperature Life with or without Electrical Load Test Procedure for Electrical Connectors*.
- 2) Test Condition at 105° C.
- 3) Test Time Condition B for 250 hours.
- 4) All test samples are pre-conditioned at ambient.
- 5) All test samples are exposed to environmental stressing in the mated condition.

### THERMAL SHOCK:

- 1) EIA-364-32, *Thermal Shock (Temperature Cycling) Test Procedure for Electrical Connectors*.
- 2) Test Condition I: -55°C to +85°C.
- 3) Test Time: ½ hour dwell at each temperature extreme.
- 4) Number of Cycles: 100
- 5) All test samples are pre-conditioned at ambient.
- 6) All test samples are exposed to environmental stressing in the mated condition.

### HUMIDITY:

- 1) Reference document: EIA-364-31, *Humidity Test Procedure for Electrical Connectors*.
- 2) Test Condition B, 240 Hours.
- 3) Method III, +25° C to + 65° C, 90% to 98% Relative Humidity excluding sub-cycles 7a and 7b.
- 4) All samples are pre-conditioned at ambient.
- 5) All test samples are exposed to environmental stressing in the mated condition.

### MECHANICAL SHOCK (Specified Pulse):

- 1) Reference document: EIA-364-27, *Mechanical Shock Test Procedure for Electrical Connectors*
- 2) Test Condition C
- 3) Peak Value: 100 G
- 4) Duration: 6 Milliseconds
- 5) Wave Form: Half Sine
- 6) Velocity: 12.3 ft/s
- 7) Number of Shocks: 3 Shocks / Direction, 3 Axis (18 Total)

### VIBRATION:

- 1) Reference document: EIA-364-28, *Vibration Test Procedure for Electrical Connectors*
- 2) Test Condition V, Letter B
- 3) Power Spectral Density: 0.04 G<sup>2</sup> / Hz
- 4) G 'RMS': 7.56
- 5) Frequency: 50 to 2000 Hz
- 6) Duration: 2.0 Hours per axis (3 axis total)

### NANOSECOND-EVENT DETECTION:

- 1) Reference document: EIA-364-87, *Nanosecond-Event Detection for Electrical Connectors*
- 2) Prior to testing, the samples were characterized to assure the low nanosecond event being monitored will trigger the detector.
- 3) After characterization it was determined the test samples could be monitored for 50 nanosecond events

### MATING/UNMATING:

- 1) Reference document: EIA-364-13, *Mating and Unmating Forces Test Procedure for Electrical Connectors*.
- 2) The full insertion position was to within 0.003" to 0.004" of the plug bottoming out in the receptacle to prevent damage to the system under test.
- 3) One of the mating parts is secured to a floating X-Y table to prevent damage during cycling.

### ATTRIBUTE DEFINITIONS Continued

The following is a brief, simplified description of attributes.

#### TEMPERATURE RISE (Current Carrying Capacity, CCC):

- 1) EIA-364-70, *Temperature Rise versus Current Test Procedure for Electrical Connectors and Sockets*.
- 2) When current passes through a contact, the temperature of the contact increases as a result of  $I^2R$  (resistive) heating.
- 3) The number of contacts being investigated plays a significant part in power dissipation and therefore temperature rise.
- 4) The size of the temperature probe can affect the measured temperature.
- 5) Copper traces on PC boards will contribute to temperature rise:
  - a. Self-heating (resistive)
  - b. Reduction in heat sink capacity affecting the heated contacts.
- 6) A de-rating curve, usually 20%, is calculated.
- 7) Calculated de-rated currents at four temperature points are reported:
  - a. Ambient
  - b. 85° C
  - c. 95° C
  - d. 115° C
- 8) Typically, neighboring contacts (in close proximity to maximize heat buildup) are energized.
- 9) The thermocouple (or temperature measuring probe) will be positioned at a location to sense the maximum temperature in the vicinity of the heat generation area.
- 10) A computer program, *TR 803.exe*, ensures accurate stability for data acquisition.
- 11) Hook-up wire cross section is larger than the cross section of any connector leads/PC board traces, jumpers, etc.
- 12) Hook-up wire length is longer than the minimum specified in the referencing standard.

#### LLCR:

- 1) EIA-364-23, *Low Level Contact Resistance Test Procedure for Electrical Connectors and Sockets*.
- 2) A computer program, *LLCR 221.exe*, ensures repeatability for data acquisition.
- 3) The following guidelines are used to categorize the changes in LLCR as a result from stressing.
  - a.  $\leq +5.0$  mOhms: -----Stable
  - b.  $+5.1$  to  $+10.0$  mOhms:-----Minor
  - c.  $+10.1$  to  $+15.0$  mOhms: -----Acceptable
  - d.  $+15.1$  to  $+50.0$  mOhms: -----Marginal
  - e.  $+50.1$  to  $+1000$  mOhms: -----Unstable
  - f.  $>+1000$  mOhms:-----Open Failure

## RESULTS

### Temperature Rise, CCC at a 20% de-rating

- CCC for a 30°C Temperature Rise-----1.27 A per contact with 8 contacts (8x1) powered.
- CCC for a 30°C Temperature Rise-----0.99 A per contact with 16 contacts (8x2) powered.
- CCC for a 30°C Temperature Rise-----0.81 A per contact with 24 contacts (8x3) powered.
- CCC for a 30°C Temperature Rise-----0.72 A per contact with 32 contacts (8x4) powered.
- CCC for a 30°C Temperature Rise-----0.26 A per contact with 800 contacts (8x100) powered.

### Mating – Unmating Forces

#### Mating/Unmating Durability Group

- **Initial**
  - **Mating**
    - Min -----34.75 lbs
    - Max-----39.57 lbs
  - **Unmating**
    - Min -----19.33 lbs
    - Max-----20.44 lbs
- **After 25 Cycles**
  - **Mating**
    - Min -----38.33 lbs
    - Max-----45.07 lbs
  - **Unmating**
    - Min -----20.15 lbs
    - Max-----21.71 lbs
- **After Humidity**
  - **Mating**
    - Min -----21.71 lbs
    - Max-----23.59 lbs
  - **Unmating**
    - Min -----10.92 lbs
    - Max-----13.18 lbs

#### Mating/Unmating Basic Group

- **Initial**
  - **Mating**
    - Min -----31.44 lbs
    - Max-----41.38 lbs
  - **Unmating**
    - Min -----14.85 lbs
    - Max-----19.58 lbs
- **After 25 Cycles**
  - **Mating**
    - Min -----37.10 lbs
    - Max-----46.14 lbs
  - **Unmating**
    - Min -----22.02 lbs
    - Max-----24.37 lbs

**RESULTS Continued**

**LLCR Thermal Aging (480 LLCR test points)**

- **Initial** ----- 27.74 mOhms Max
- **Thermal Aging**
  - <= +5.0 mOhms-----468 Points ----- Stable
  - +5.1 to +10.0 mOhms ----- 11 Points ----- Minor
  - +10.1 to +15.0 mOhms -----1 Points ----- Acceptable
  - +15.1 to +50.0 mOhms -----0 Points ----- Marginal
  - +50.1 to +1000 mOhms-----0 Points ----- Unstable
  - >+1000 mOhms-----0 Points ----- Open Failure

**LLCR Durability (960 LLCR test points)**

- **Initial** ----- 25.27 mOhms Max
- **Durability, 25 Cycles**
  - <= +5.0 mOhms-----957 Points ----- Stable
  - +5.1 to +10.0 mOhms -----3 Points ----- Minor
  - +10.1 to +15.0 mOhms -----0 Points ----- Acceptable
  - +15.1 to +50.0 mOhms -----0 Points ----- Marginal
  - +50.1 to +1000 mOhms-----0 Points ----- Unstable
  - >+1000 mOhms-----0 Points ----- Open Failure
- **Thermal**
  - <= +5.0 mOhms-----908 Points ----- Stable
  - +5.1 to +10.0 mOhms ----- 52 Points ----- Minor
  - +10.1 to +15.0 mOhms -----0 Points ----- Acceptable
  - +15.1 to +50.0 mOhms -----0 Points ----- Marginal
  - +50.1 to +1000 mOhms-----0 Points ----- Unstable
  - >+1000 mOhms-----0 Points ----- Open Failure
- **Humidity**
  - <= +5.0 mOhms-----883 Points ----- Stable
  - +5.1 to +10.0 mOhms ----- 60 Points ----- Minor
  - +10.1 to +15.0 mOhms ----- 17 Points ----- Acceptable
  - +15.1 to +50.0 mOhms -----0 Points ----- Marginal
  - +50.1 to +1000 mOhms-----0 Points ----- Unstable
  - >+1000 mOhms-----0 Points ----- Open Failure

**RESULTS Continued**

**LLCR Shock & Vibration (960 LLCR test points)**

- **Initial** ----- 22.36 mOhms Max
- **Shock & Vibration**
  - **<= +5.0 mOhms**-----960 Points ----- Stable
  - **+5.1 to +10.0 mOhms**-----0 Points ----- Minor
  - **+10.1 to +15.0 mOhms** -----0 Points ----- Acceptable
  - **+15.1 to +50.0 mOhms** -----0 Points ----- Marginal
  - **+50.1 to +1000 mOhms**-----0 Points ----- Unstable
  - **>+1000 mOhms**-----0 Points ----- Open Failure

**Mechanical Shock & Random Vibration:**

- **Shock**
  - **No Damage**----- Pass
  - **50 Nanoseconds** ----- Pass
- **Vibration**
  - **No Damage**----- Pass
  - **50 Nanoseconds** ----- Pass

### DATA SUMMARIES

#### TEMPERATURE RISE (Current Carrying Capacity, CCC):

- 1) High quality thermocouples whose temperature slopes track one another were used for temperature monitoring.
- 2) The thermocouples were placed at a location to sense the maximum temperature generated during testing.
- 3) Temperature readings recorded are those for which three successive readings, 15 minutes apart, differ less than 1° C (computer-controlled data acquisition).
- 4) Adjacent contacts were powered:
  - a. Linear configuration with 8 adjacent conductors/contacts powered.

**CR-1088502**  
**8 (8x1) Contacts in Series**  
**Part Numbers: APF6-100-03.5-S-08-0-A-TR / APM6-100-01.5-S-08-0-A-TR**

*Current Rating per Contact (30 Deg. Rise, 20% Derated) = 1.27 Amps*

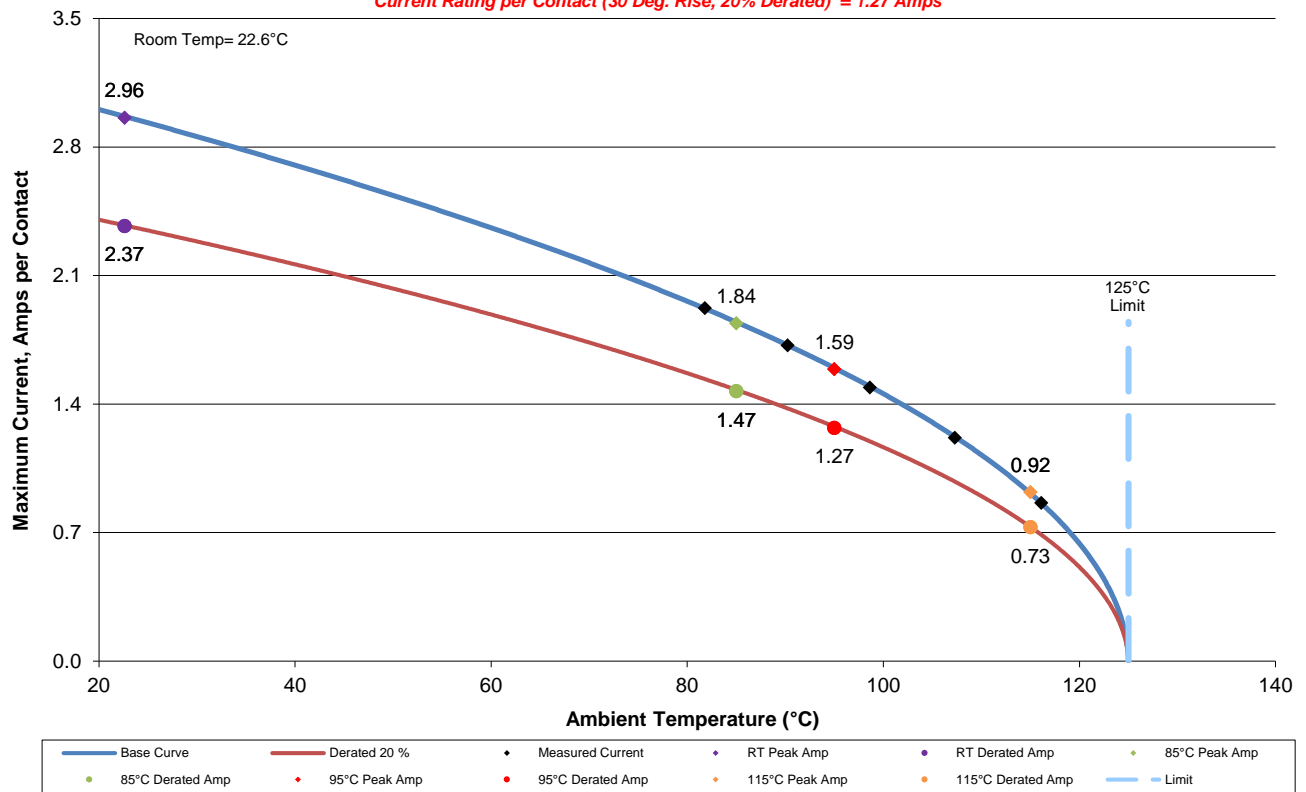

### DATA SUMMARIES Continued

CR-1088502  
8 (8X1) Contacts in Series  
Part Numbers: APF6-100-03.5-S-08-0-A-TR / APM6-100-01.5-S-08-0-A-TR

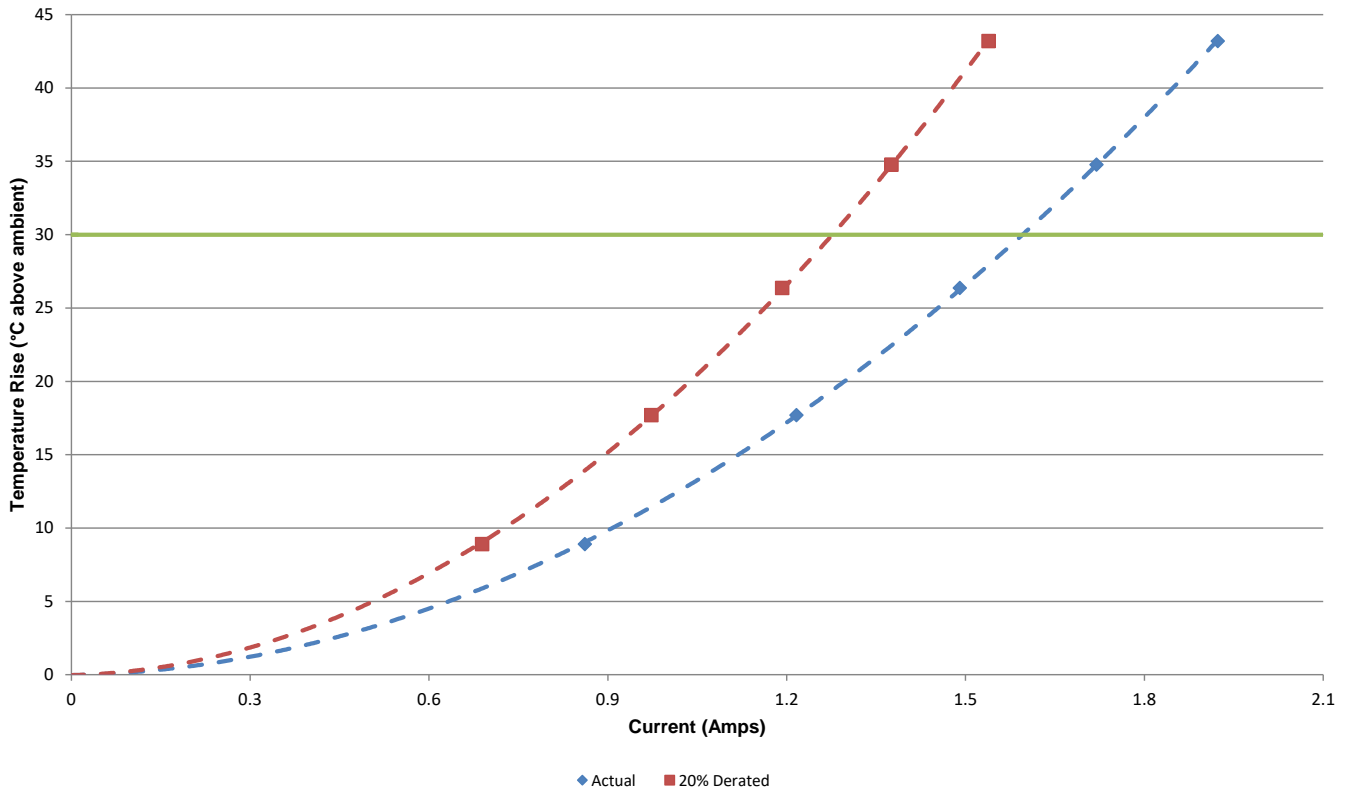

### DATA SUMMARIES Continued

b. Linear configuration with 16 adjacent conductors/contacts powered.

CR-1088502  
 16 (8x2) Contacts in Series  
 Part Numbers: APF6-100-03.5-S-08-0-A-TR / APM6-100-01.5-S-08-0-A-TR

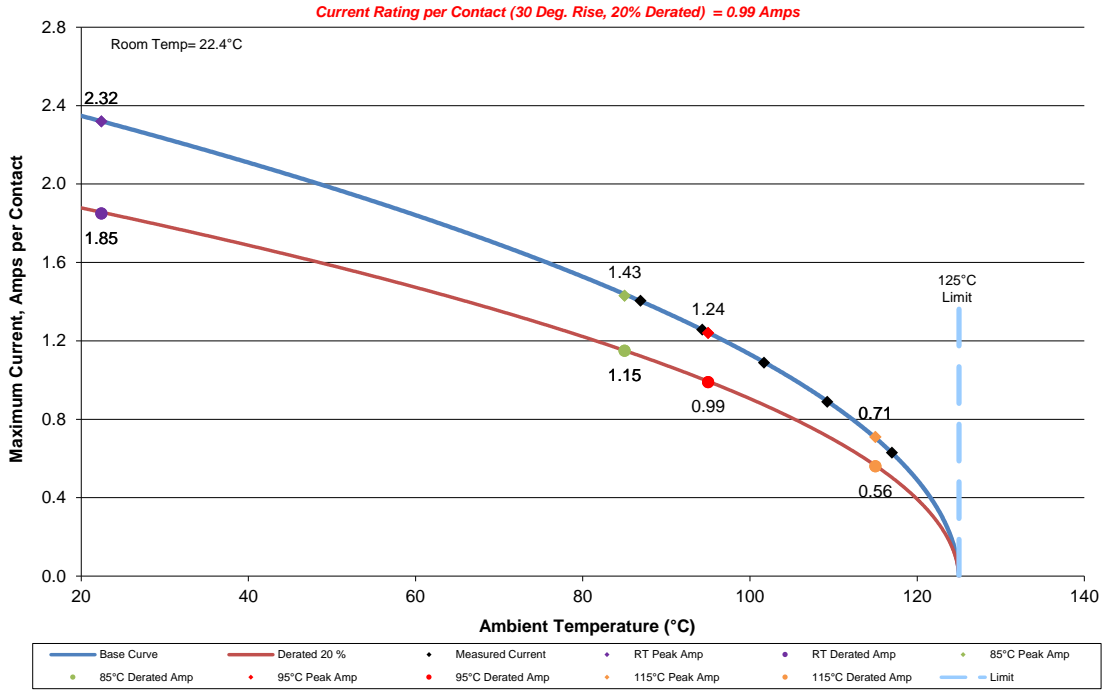

CR-1088502  
 16 (8X2) Contacts in Series  
 Part Numbers: APF6-100-03.5-S-08-0-A-TR / APM6-100-01.5-S-08-0-A-TR

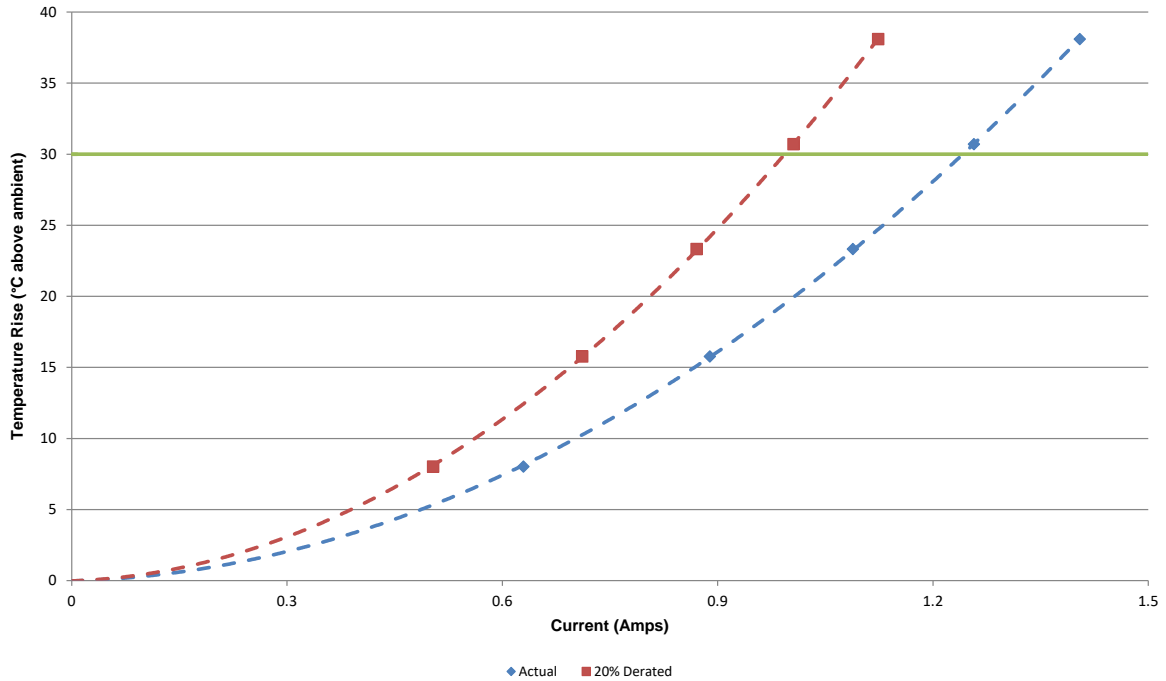

### DATA SUMMARIES Continued

c. Linear configuration with 24 adjacent conductors/contacts powered.

CR-1088502  
 24 (8x3) Contacts in Series  
 Part Numbers: APF6-100-03.5-S-08-0-A-TR / APM6-100-01.5-S-08-0-A-TR

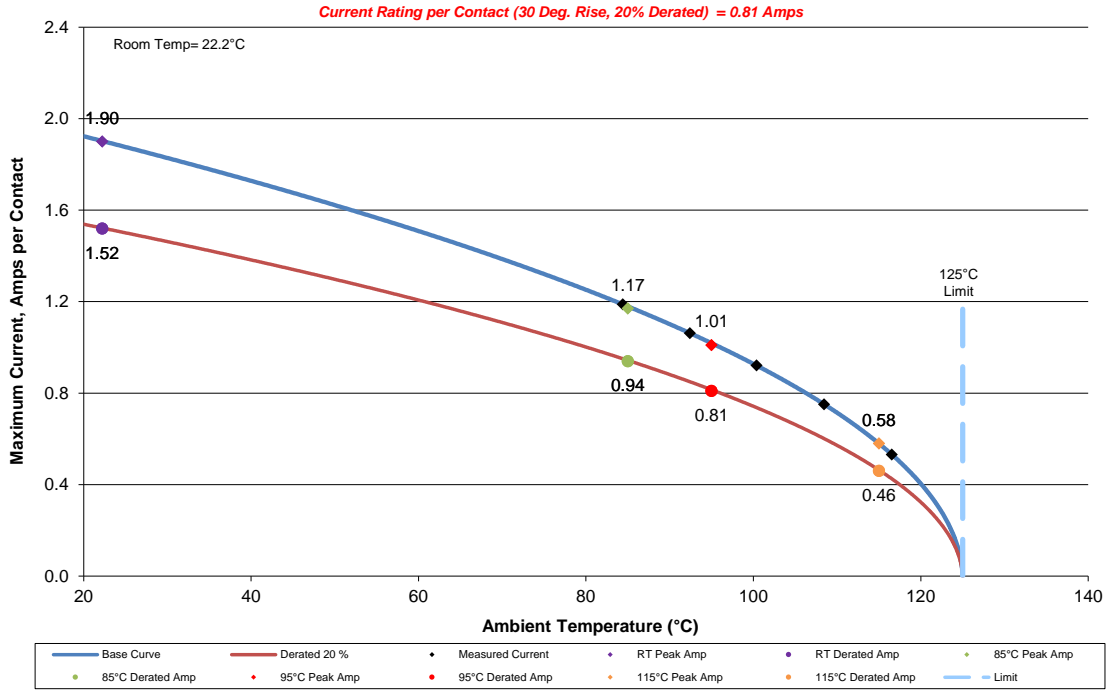

CR-1088502  
 24 (8X3) Contacts in Series  
 Part Numbers: APF6-100-03.5-S-08-0-A-TR / APM6-100-01.5-S-08-0-A-TR

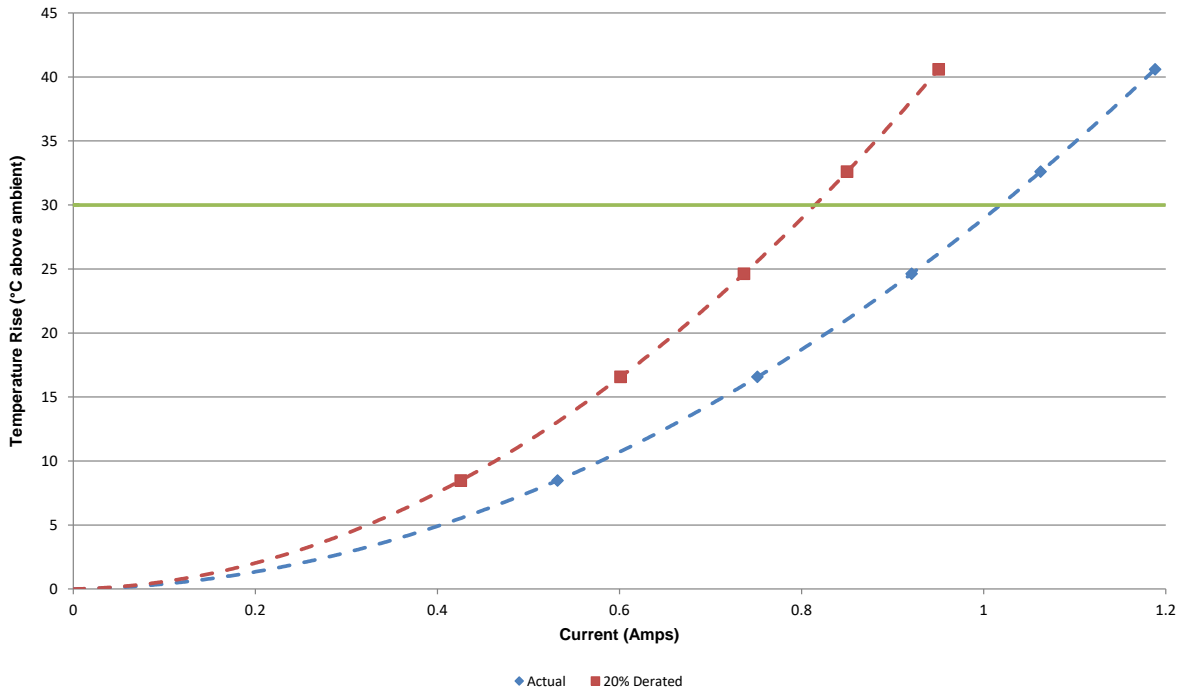

### DATA SUMMARIES Continued

d. Linear configuration with 32 adjacent conductors/contacts powered.

CR-1088502  
 32 (8x4) Contacts in Series  
 Part Numbers: APF6-100-03.5-S-08-0-A-TR / APM6-100-01.5-S-08-0-A-TR

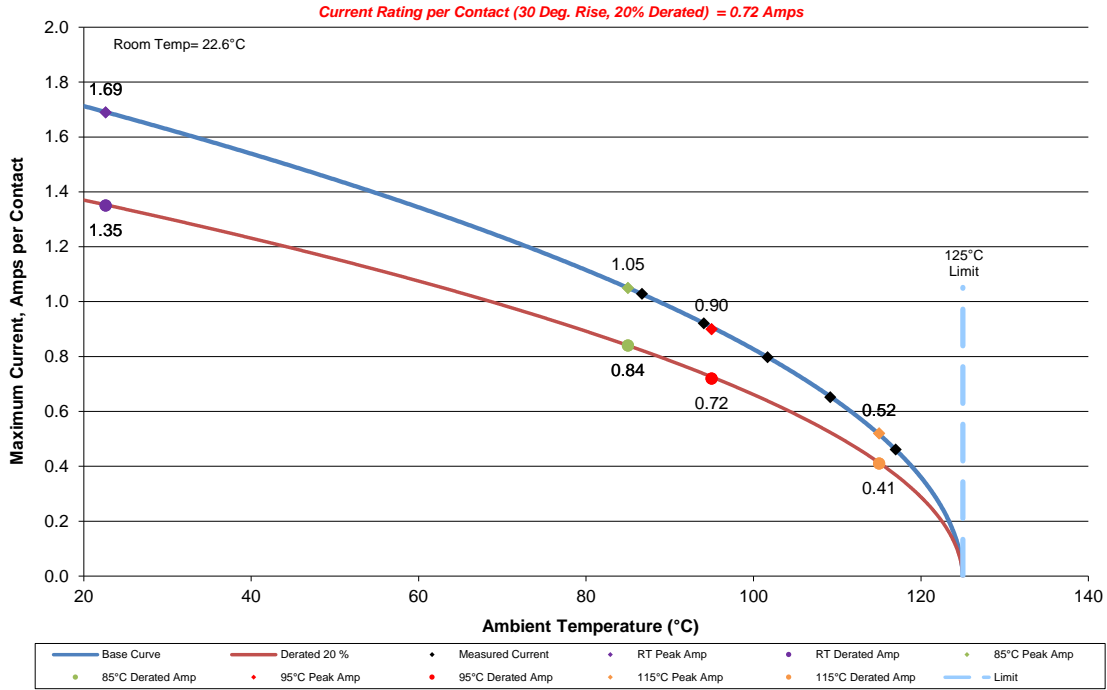

CR-1088502  
 32 (8x4) Contacts in Series  
 Part Numbers: APF6-100-03.5-S-08-0-A-TR / APM6-100-01.5-S-08-0-A-TR

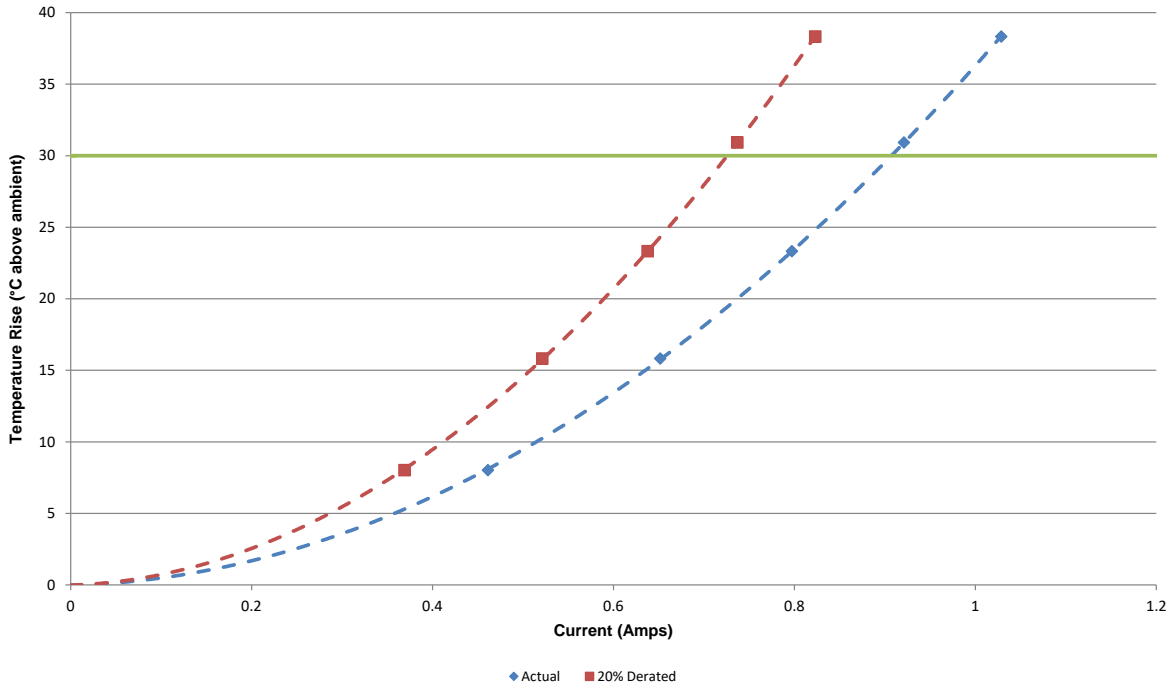

### DATA SUMMARIES Continued

e. Linear configuration with 800 adjacent conductors/contacts powered.

CR-1088502  
 800 (8x100)(All Power) Contacts in Series  
 Part Numbers: APF6-100-03.5-S-08-0-A-TR / APM6-100-01.5-S-08-0-A-TR

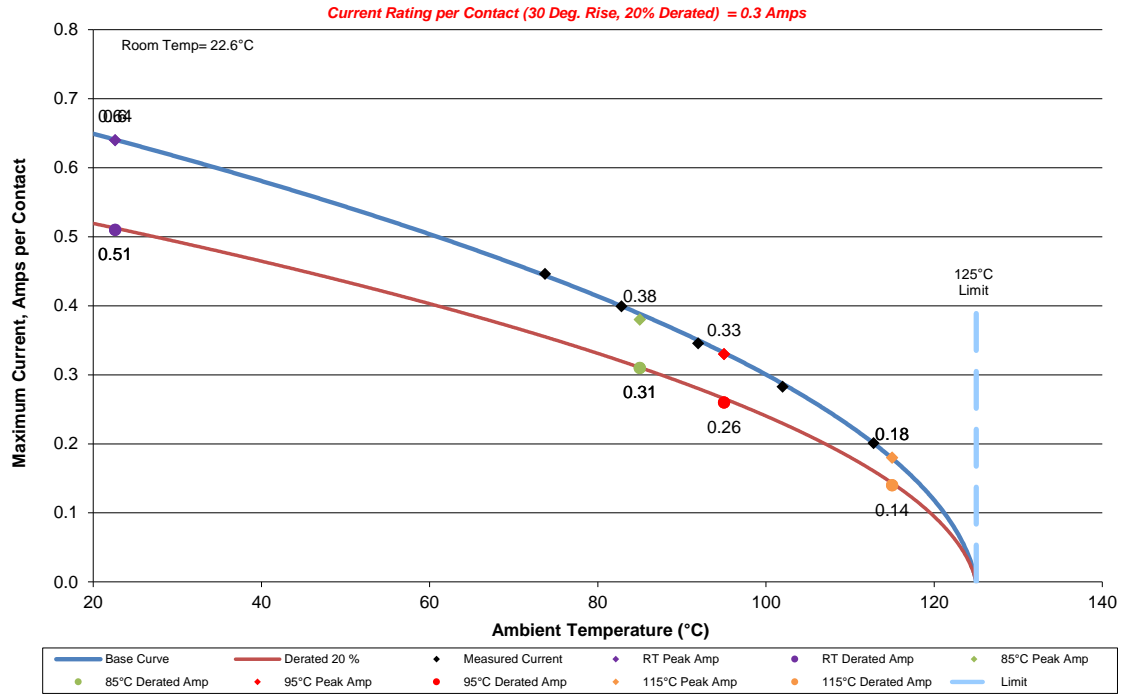

CR-1088502  
 800 (8X100)(All Power) Contacts in Series  
 Part Numbers: APF6-100-03.5-S-08-0-A-TR / APM6-100-01.5-S-08-0-A-TR

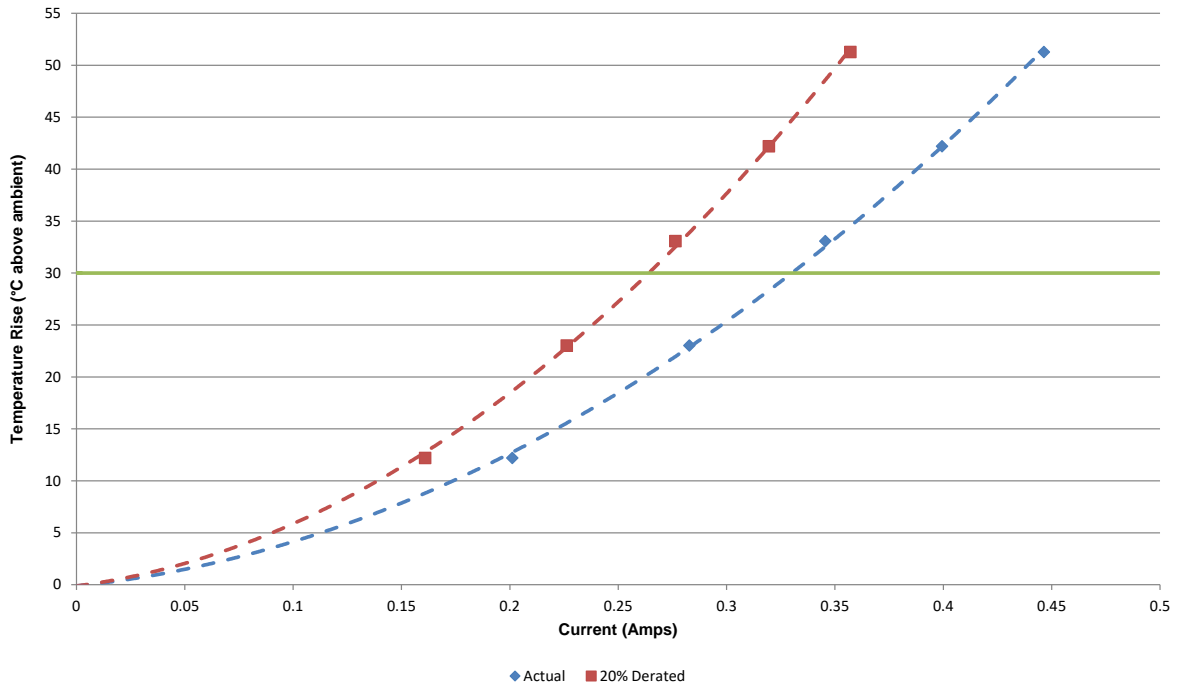

**DATA SUMMARIES Continued****MATING/UNMATING:****Mating/Unmating Durability Group**

	Initial				25 Cycles			
	Mating		Unmating		Mating		Unmating	
	Newton	Force (Lbs)	Newton	Force (Lbs)	Newton	Force (Lbs)	Newton	Force (Lbs)
Minimum	154.57	34.75	85.98	19.33	170.49	38.33	89.63	20.15
Maximum	176.01	39.57	90.92	20.44	200.47	45.07	96.57	21.71
<b>Average</b>	163.28	<b>36.71</b>	88.38	<b>19.87</b>	184.61	<b>41.50</b>	93.68	<b>21.06</b>
St Dev	7.19	1.62	1.73	0.39	10.39	2.34	2.26	0.51
Count	8	8	8	8	8	8	8	8
	After Humidity							
	Mating		Unmating					
	Newton	Force (Lbs)	Newton	Force (Lbs)				
Minimum	96.57	21.71	48.57	10.92				
Maximum	104.93	23.59	58.62	13.18				
<b>Average</b>	100.31	<b>22.55</b>	53.85	<b>12.11</b>				
St Dev	2.61	0.59	2.97	0.67				
Count	8	8	8	8				

**Mating/Unmating Basic Group**

	Initial				After 25 Cycles			
	Mating		Unmating		Mating		Unmating	
	Newton	Force (Lbs)	Newton	Force (Lbs)	Newton	Force (Lbs)	Newton	Force (Lbs)
Minimum	139.85	31.44	66.05	14.85	165.02	37.10	97.94	22.02
Maximum	184.06	41.38	87.09	19.58	205.23	46.14	108.40	24.37
<b>Average</b>	161.79	<b>36.37</b>	80.21	<b>18.03</b>	187.72	<b>42.20</b>	104.52	<b>23.50</b>
St Dev	13.95	3.14	7.11	1.60	13.06	2.94	3.27	0.74
Count	8	8	8	8	8	8	8	8

### DATA SUMMARIES Continued

**LLCR Thermal Aging:**

- 1) A total of 480 points were measured.
- 2) EIA-364-23, *Low Level Contact Resistance Test Procedure for Electrical Connectors and Sockets*.
- 3) A computer program, *LLCR 221.exe*, ensures repeatability for data acquisition.
- 4) The following guidelines are used to categorize the changes in LLCR as a result from stressing.
  - a.  $\leq +5.0$  mOhms: -----Stable
  - b.  $+5.1$  to  $+10.0$  mOhms:-----Minor
  - c.  $+10.1$  to  $+15.0$  mOhms: -----Acceptable
  - d.  $+15.1$  to  $+50.0$  mOhms: -----Marginal
  - e.  $+50.1$  to  $+1000$  mOhms: -----Unstable
  - f.  $>+1000$  mOhms:-----Open Failure

LLCR Measurement Summaries by Pin Type		
Date	2024/12/11	2024/12/23
Room Temp (Deg C)	22	22
Rel Humidity (%)	35	23
Technician	Richard Ison	Richard Ison
<b>mOhm values</b>	<b>Actual</b>	<b>Delta</b>
	<b>Initial</b>	<b>Thermal</b>
Pin Type: Signal 1		
Average	19.98	1.28
St. Dev.	1.73	1.39
Min	16.21	0
Max	27.74	10.59
Summary Count	480	480
Total Count	480	480

LLCR Delta Count by Category						
	Stable	Minor	Acceptable	Marginal	Unstable	Open
<b>mOhms</b>	<b><math>\leq 5</math></b>	<b><math>&gt;5 \ \&amp; \ \leq 10</math></b>	<b><math>&gt;10 \ \&amp; \ \leq 15</math></b>	<b><math>&gt;15 \ \&amp; \ \leq 50</math></b>	<b><math>&gt;50 \ \&amp; \ \leq 1000</math></b>	<b><math>&gt;1000</math></b>
<b>Thermal</b>	<b>468</b>	<b>11</b>	<b>1</b>	<b>0</b>	<b>0</b>	<b>0</b>

### DATA SUMMARIES Continued

**LLCR Durability:**

- 1) A total of 960 points were measured.
- 2) EIA-364-23, *Low Level Contact Resistance Test Procedure for Electrical Connectors and Sockets*.
- 3) A computer program, *LLCR 221.exe*, ensures repeatability for data acquisition.
- 4) The following guidelines are used to categorize the changes in LLCR as a result from stressing.
  - a.  $\leq +5.0$  mOhms: -----Stable
  - b.  $+5.1$  to  $+10.0$  mOhms: -----Minor
  - c.  $+10.1$  to  $+15.0$  mOhms: -----Acceptable
  - d.  $+15.1$  to  $+50.0$  mOhms: -----Marginal
  - e.  $+50.1$  to  $+1000$  mOhms: -----Unstable
  - f.  $>+1000$  mOhms: -----Open Failure

LLCR Measurement Summaries by Pin Type				
Date	2024/6/3	2024/6/6	2024/6/19	2024/7/3
Room Temp (Deg C)	22	22	22	22
Rel Humidity (%)	52	53	55	56
Technician	Brian Stemle	Brian Stemle	Brian Stemle	Matthew Gramlin
<b>mOhm values</b>	<b>Actual Initial</b>	<b>Delta Cycles</b>	<b>Delta Therm Shck</b>	<b>Delta Humidity</b>
Pin Type: Signal 1				
Average	18.23	0.75	2.01	1.87
St. Dev.	1.41	0.78	1.41	2.14
Min	15.1	0	0	0
Max	25.27	7.98	7.78	14.29
Summary Count	960	960	960	960
Total Count	960	960	960	960

LLCR Delta Count by Category						
	Stable	Minor	Acceptable	Marginal	Unstable	Open
<b>mOhms</b>	$\leq 5$	$>5 \ \& \ \leq 10$	$>10 \ \& \ \leq 15$	$>15 \ \& \ \leq 50$	$>50 \ \& \ \leq 1000$	$>1000$
<b>Cycles</b>	957	3	0	0	0	0
<b>Therm Shck</b>	908	52	0	0	0	0
<b>Humidity</b>	883	60	17	0	0	0

### DATA SUMMARIES Continued

**LLCR Shock &Vibration:**

- 1). A total of 960 points were measured.
- 2). EIA-364-23, *Low Level Contact Resistance Test Procedure for Electrical Connectors and Sockets.*
- 3). The following guidelines are used to categorize the changes in LLCR as a result from stressing.
  - a. <= +5.0 mOhms: -----Stable
  - b. +5.1 to +10.0 mOhms: -----Minor
  - c. +10.1 to +15.0 mOhms: -----Acceptable
  - d. +15.1 to +50.0 mOhms: -----Marginal
  - e. +50.1 to +1000 mOhms -----Unstable
  - f. >+1000 mOhms:-----Open Failure

LLCR Measurement Summaries by Pin Type		
Date	2024/5/15	2024/9/5
Room Temp (Deg C)	22	21
Rel Humidity (%)	54	52
Technician	Brian Stemle	Brian Stemle
<b>mOhm values</b>	<b>Actual</b>	<b>Delta</b>
	<b>Initial</b>	<b>Shock-Vib</b>
Pin Type: Signal 1		
Average	18.03	0.83
St. Dev.	1.26	0.68
Min	15.45	0
Max	22.36	4.4
Summary Count	960	960
Total Count	960	960

LLCR Delta Count by Category						
	Stable	Minor	Acceptable	Marginal	Unstable	Open
<b>mOhms</b>	<=5	>5 & <=10	>10 & <=15	>15 & <=50	>50 & <=1000	>1000
<b>Shock-Vib</b>	960	0	0	0	0	0

**Nanosecond Event Detection:**

Shock and Vibration Event Detection Summary	
Contacts tested	60
Test Condition	C, 100g's, 6ms, Half-Sine
Shock Events	0
Test Condition	V-B, 7.56 rms g
Vibration Events	0
<b>Total Events</b>	<b>0</b>

**EQUIPMENT AND CALIBRATION SCHEDULES****Equipment #:** TCT-04**Description:** Dillon Quantrol TC21 25-1000 mm/min series test stand**Manufacturer:** Dillon Quantrol**Model:** TC2 I series test stand**Serial #:** 04-1041-04**Accuracy:** Speed Accuracy: +/- 5% of indicated speed; Speed Accuracy: +/- 5% of indicated speed;  
... Last Cal: 05/29/2024, Next Cal: 05/29/2025**Equipment #:** MO-11**Description:** Switch/Multimeter**Manufacturer:** Keithley**Model:** 3706**Serial #:** 120169**Accuracy:** See Manual

... Last Cal: 09/11/2023, Next Cal: 09/11/2024

**Equipment #:** TSC-01**Description:** Vertical Thermal Shock Chamber**Manufacturer:** Cincinnati Sub Zero**Model:** VTS-3-6-6-SC/AC**Serial #:** 10-VT14993**Accuracy:** See Manual

... Last Cal: 06/30/2024, Next Cal: 06/30/2025

**Equipment #:** THC-05**Description:** Temperature/Humidity Chamber (Chamber Room)**Manufacturer:** Thermotron**Model:** SM-8-3800**Serial #:** 05 23 00 02**Accuracy:** See Manual

... Last Cal: 11/14/2023, Next Cal: 11/14/2024

**Equipment #:** HPT-01**Description:** Hipot Safety Tester**Manufacturer:** Vitrek**Model:** V73**Serial #:** 019808**Accuracy:**

... Last Cal: 05/15/2024, Next Cal: 05/15/2025

**EQUIPMENT AND CALIBRATION SCHEDULES****Equipment #:** PS-02**Description:** Power Supply**Manufacturer:** Hewlett-Packard**Model:** 6033A**Serial #:** N/A**Accuracy:** See Manual

... Last Cal: NOT CALIBRATED

**Equipment #:** MO-04**Description:** Multimeter /Data Acquisition System**Manufacturer:** Keithley**Model:** 2700**Serial #:** 0798688**Accuracy:** See Manual

... Last Cal: 09/11/2023, Next Cal: 09/11/2024

**Equipment #:** SVC-01**Description:** Shock & Vibration Table**Manufacturer:** Data Physics**Model:** LE-DSA-10-20K**Serial #:** 10037**Accuracy:** See Manual

... Last Cal: 04/22/2024, Next Cal: 04/22/2025

**Equipment #:** ACLM-01**Description:** Accelerometer**Manufacturer:** PCB Piezotronics**Model:** 352C03**Serial #:** 115819**Accuracy:** See Manual

... Last Cal: 07/18/2024, Next Cal: 07/18/2025

**Equipment #:** ED-03**Description:** Event Detector**Manufacturer:** Analysis Tech**Model:** 32EHD**Serial #:** 1100604**Accuracy:** See Manual

... Last Cal: 10/31/2023, Next Cal: 10/31/2024