

Project: Design Qualification Test Report	Tracking Code: CR-1119204_Report_Rev_1
Requested by: Eric Tseng	Date: 12/24/2025
Part #: EBTC-4-08-1/EBCE-X-4-08-LU-1-XX-LU-1, EBTC-6-08-1/EBCE-X-6-08-LU-1-XX-LU-1	
Part description: EBTC/EBCE	Tech: Kason He
Test Start: 7/17/2024	Test Completed: 8/13/2024

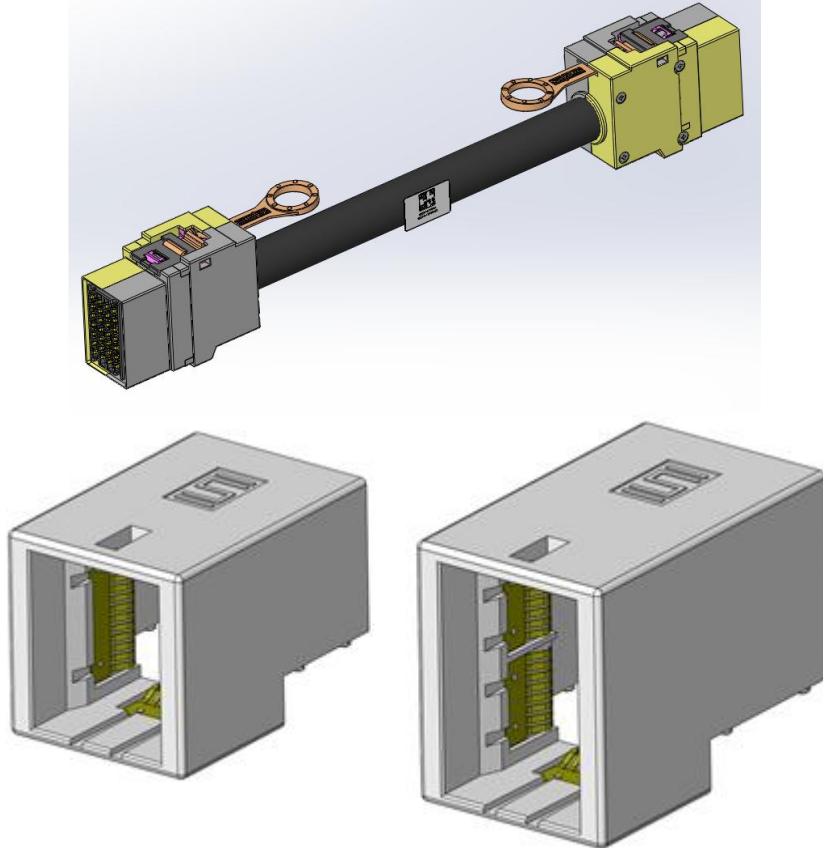

DESIGN QUALIFICATION TEST REPORT

EBTC/EBCE

EBTC-4-08-1/EBCE-X-4-08-LU-1-XX-LU-1

EBTC-6-08-1/EBCE-X-6-08-LU-1-XX-LU-1

Tracking Code: CR-1119204_Report_Rev_1	Part #: EBTC-4-08-1/EBCE-X-4-08-LU-1-XX-LU-1 EBTC-6-08-1/EBCE-X-6-08-LU-1-XX-LU-1
Part description: EBTC/EBCE	

REVISION HISTORY

DATA	REV.NUM.	DESCRIPTION	ENG
12/24/2025	1	Initial test	KH

CERTIFICATION

All instruments and measuring equipment were calibrated to National Institute for Standards and Technology (NIST) traceable standards according to ISO 10012-1 and ANSI/NCSL 2540-1, as applicable.

All contents contained herein are the property of Samtec. No portion of this report, in part or full, all be reproduced without prior written approval of Samtec.

SCOPE

To perform the following tests: Design Qualification test. Please see test plan.

APPLICABLE DOCUMENTS

Standards: EIA Publication 364

TEST SAMPLES AND PREPARATION

- 1) All materials were manufactured in accordance with the applicable product specification.
- 2) All test samples were identified and encoded to maintain traceability throughout the test sequences.
- 3) After soldering, the parts to be used for LLCR and DWV/IR testing were cleaned according to CO-SC-WI-3029.
- 4) Either an automated cleaning procedure or an ultrasonic cleaning procedure may be used.
- 5) The automated procedure is used with aqueous compatible soldering materials.
- 6) Parts not intended for testing LLCR and DWV/IR are visually inspected and cleaned if necessary.
- 7) Any additional preparation will be noted in the individual test sequences.
- 8) Solder Information: Lead Free
- 9) Samtec Test PCBs used: PCB-112765-TST/PCB-113145-TST/PCB-113146-TST/PCB-114277-TST.
PCB-114064-TST/PCB-113249-TST/PCB-113250-TST.

FLOWCHARTS**Normal Force**Group 1
EBTC-4-08-18 Contacts Minimum
EMI Spring Finger*Note: COMPRESS ALL CONTACTS IN ONE
SPRING FINGER PER MEASUREMENT*

Step	Description
1.	Contact Gaps
2.	Normal Force ⁽¹⁾ Deflection = 0.75 mm Normal force at maximum deflection = 3200 g

Group 2
EBTC-4-08-18 Contacts Minimum
EMI Spring Finger*Note: COMPRESS ONE CONTACT IN ONE
SPRING FINGER PER MEASUREMENT*

Step	Description
1.	Contact Gaps
2.	Normal Force ⁽¹⁾ Normal force at maximum deflection = 400 g Deflection = 0.75 mm

(1) Normal Force = EIA-364-04

Normal ForceGroup 1
EBTC-6-08-18 Contacts Minimum
EMI Spring Finger*Note: COMPRESS ALL CONTACTS IN ONE
SPRING FINGER PER MEASUREMENT*

Step	Description
1.	Contact Gaps
2.	Normal Force ⁽¹⁾ Deflection = 0.75 mm Normal force at maximum deflection = 1600 g

Group 2
EBTC-6-08-18 Contacts Minimum
EMI Spring Finger*Note: COMPRESS ONE CONTACT IN ONE
SPRING FINGER PER MEASUREMENT*

Step	Description
1.	Contact Gaps
2.	Normal Force ⁽¹⁾ Deflection = 0.75 mm Normal force at maximum deflection = 400 g

(1) Normal Force = EIA-364-04

FLOWCHARTS Continued**Mating/Unmating/Durability**Group 1

EBCE-1-4-08-LU-1-12-LU-1

EBTC-4-08-1/EBTM-4-08-2.0-S-RA-1

3 Assemblies

Note: 100% LLCR

Step	Description
1.	Contact Gaps <i>Note: EBTC-4-XX-X print C1 and C2 dimensions. EBCE-X-4-08-X-XX-X print C9 dimension. EBTM-4-XX-2.0-X-RA-X-X-X print C2 dimension.</i> <i>Note: Check each end and middle of each row</i>
2.	LLCR ⁽²⁾ <i>Note: Please separate twinax and coax when reporting</i>
3.	Mating/Unmating Force ⁽³⁾
4.	Cycles Quantity = 25 Cycles
5.	Mating/Unmating Force ⁽³⁾
6.	Cycles Quantity = 25 Cycles
7.	Mating/Unmating Force ⁽³⁾
8.	Cycles Quantity = 25 Cycles
9.	Mating/Unmating Force ⁽³⁾
10.	Cycles Quantity = 25 Cycles
11.	Mating/Unmating Force ⁽³⁾
12.	Contact Gaps

FLOWCHARTS Continued

Note: EBTC-4-XX-X print C1 and C2 dimensions.

EBCE-X-4-08-X-XX-X print C9 dimension.

EBTM-4-XX-2.0-X-RA-X-X-X print C2 dimension.

Note: Check each end and middle of each row

13. **LLCR** ⁽²⁾
Max Delta = 15 mOhm
Note: Please separate twinax and coax when reporting
14. **Thermal Shock** ⁽⁴⁾ - Non Standard
15. **LLCR** ⁽²⁾
Max Delta = 15 mOhm
Note: Please separate twinax and coax when reporting
16. **Humidity** ⁽¹⁾
17. **LLCR** ⁽²⁾
Max Delta = 15 mOhm
Note: Please separate twinax and coax when reporting
18. **Mating/Unmating Force** ⁽³⁾

(1) Humidity = EIA-364-31

Test Condition = B (240 Hours)

Test Method = III (+25°C to +65°C @ 90% RH to 98% RH)

Test Exceptions: ambient pre-condition and delete steps 7a and 7b

(2) LLCR = EIA-364-23

Open Circuit Voltage = 20 mV Max

Test Current = 100 mA Max

(3) Mating/Unmating Force = EIA-364-13

(4) Thermal Shock = Other

Exposure Time at Temperature Extremes = 1/2 Hour

Method A, Test Condition = I (-40°C to +85°C)

Test Duration = A-3 (100 Cycles)

Twinax cable (TX-34100CU-T01-S) is only rated down to -40°C

FLOWCHARTS Continued**Mating/Unmating/Durability**Group 1

EBCE-1-6-08-LU-1-12-LU-1

EBTC-6-08-1/EBTM-6-08-2.0-S-RA-1

3 Assemblies

Note: 100% LLCR

Step	Description
1.	Contact Gaps <i>Note: Check each end and middle of each row</i> <i>Note: EBTC-6-XX-X print C1 and C2 spring finger contact gaps.</i> <i>EBCE-X-6-XX-LX-X-XX-LX-X print \varnothing dimension.</i> <i>EBTM-6-XX-2.0-X-RA-X-X-X print C2 dimension.</i>
2.	LLCR ⁽²⁾ <i>Note: Please separate twinax and coax when reporting</i>
3.	Mating/Unmating Force ⁽³⁾
4.	Cycles Quantity = 25 Cycles
5.	Mating/Unmating Force ⁽³⁾
6.	Cycles Quantity = 25 Cycles
7.	Mating/Unmating Force ⁽³⁾
8.	Cycles Quantity = 25 Cycles
9.	Mating/Unmating Force ⁽³⁾
10.	Cycles Quantity = 25 Cycles
11.	Mating/Unmating Force ⁽³⁾
12.	Contact Gaps <i>Note: Check each end and middle of each row</i>

FLOWCHARTS Continued

*Note: EBTC-6-XX-X print C1 and C2
spring finger contact gaps.*

*EBCE-X-6-XX-LX-X-XX-LX-X print Ⓞ
dimension.*

*EBTM-6-XX-2.0-X-RA-X-X-X print Ⓞ
dimension.*

13. **LLCR** ⁽²⁾
Max Delta = 15 mOhm
*Note: Please separate twinax and
coax when reporting*
14. **Thermal Shock** ⁽⁴⁾ - Non Standard
15. **LLCR** ⁽²⁾
Max Delta = 15 mOhm
*Note: Please separate twinax and
coax when reporting*
16. **Humidity** ⁽¹⁾
17. **LLCR** ⁽²⁾
Max Delta = 15 mOhm
*Note: Please separate twinax and
coax when reporting*
18. **Mating/Unmating Force** ⁽³⁾

(1) Humidity = EIA-364-31

Test Condition = B (240 Hours)

Test Method = III (+25°C to +65°C @ 90% RH to 98% RH)

Test Exceptions: ambient pre-condition and delete steps 7a and 7b

(2) LLCR = EIA-364-23

Open Circuit Voltage = 20 mV Max

Test Current = 100 mA Max

(3) Mating/Unmating Force = EIA-364-13

(4) Thermal Shock = Other

Exposure Time at Temperature Extremes = 1/2 Hour

Method A, Test Condition = I (-40°C to +85°C)

Test Duration = A-3 (100 Cycles)

Twinax cable (TX-34100CU-T01-S) is only rated down to -40°C

FLOWCHARTS Continued**Mechanical Shock/Random Vibration/LLCR**Group 1

EBCE-1-4-08-LU-1-12-LU-1

EBTC-4-08-1/EBTM-4-08-2.0-S-RA-1

4 Assemblies

Step	Description
1.	Pre-Condition Matin/Unmating = 5 Cycles
2.	LLCR (1)
3.	Mechanical Shock (2) - Non Standard
4.	Random Vibration (3) - Non Standard
5.	Visual Inspection
6.	LLCR (1) Max Delta = 15 mOhm

(1) LLCR = EIA-364-23Open Circuit Voltage = 20 mV Max
Test Current = 100 mA Max**(2) Mechanical Shock = Other**EIA-364-27
Test Condition = H (30 G Peak, 11 milliseconds, Half Sine)
Number of Shocks = 3 Per Direction, Per Axis, 18 Total**(3) Random Vibration = Other**EIA-364-28
Test Condition = VII, letter D (3.1G RMS, 2 Hours/Axis)**Mechanical Shock/Random Vibration/Event Detection**Group 1

EBCE-1-4-08-LU-1-12-LU-1

EBTC-4-08-1/EBTM-4-08-2.0-S-RA-1

60 Points

Step	Description
1.	Nanosecond Event Detection (Mechanical Shock) (1) - Non Standard
2.	Nanosecond Event Detection (Random Vibration) (2) - Non Standard

(1) Nanosecond Event Detection (Mechanical Shock) = OtherUse EIA-364-87 for Nanosecond Event Detection:
Test Condition = F (50 nanoseconds at 10 ohms)

Use EIA-364-27 for Mechanical Shock:

Test Condition = H (30 G Peak, 11 milliseconds, Half Sine)
Number of Shocks = 3 Per Direction, Per Axis, 18 Total**(2) Nanosecond Event Detection (Random Vibration) = Other**Use EIA-364-87 for Nanosecond Event Detection:
Test Condition = F (50 nanoseconds at 10 ohms)

Use EIA-364-28 for Random Vibration:

Test Condition = VII, letter D (3.1G RMS, 2 Hours/Axis)

FLOWCHARTS Continued**Mechanical Shock/Random Vibration/LLCR**Group 1

EBCE-1-6-08-LU-1-12-LU-1

EBTC-6-08-1/EBTM-6-08-2.0-S-RA-1

4 Assemblies

Step	Description
1.	Pre-Condition Mating/Unmating = 5 Cycles
2.	LLCR (1)
3.	Mechanical Shock (2) - Non Standard
4.	Random Vibration (3) - Non Standard
5.	Visual Inspection
6.	LLCR (1) Max Delta = 15 mOhm

(1) LLCR = EIA-364-23Open Circuit Voltage = 20 mV Max
Test Current = 100 mA Max**(2) Mechanical Shock = Other**EIA-364-27
Test Condition = H (30 G Peak, 11 milliseconds, Half Sine)
Number of Shocks = 3 Per Direction, Per Axis, 18 Total**(3) Random Vibration = Other**EIA-364-28
Test Condition = VII, letter D (3.1G RMS, 2 Hours/Axis)**Mechanical Shock/Random Vibration/Event Detection**Group 1

EBCE-1-6-08-LU-1-12-LU-1

EBTC-6-08-1/EBTM-6-08-2.0-S-RA-1

60 Points

Step	Description
1.	Nanosecond Event Detection (Mechanical Shock) (1) - Non Standard
2.	Nanosecond Event Detection (Random Vibration) (2) - Non Standard

(1) Nanosecond Event Detection (Mechanical Shock) = OtherUse EIA-364-87 for Nanosecond Event Detection:
Test Condition = F (50 nanoseconds at 10 ohms)
Use EIA-364-27 for Mechanical Shock:
Test Condition = H (30 G Peak, 11 milliseconds, Half Sine)
Number of Shocks = 3 Per Direction, Per Axis, 18 Total**(2) Nanosecond Event Detection (Random Vibration) = Other**Use EIA-364-87 for Nanosecond Event Detection:
Test Condition = F (50 nanoseconds at 10 ohms)
Use EIA-364-28 for Random Vibration:
Test Condition = VII, letter D (3.1G RMS, 2 Hours/Axis)

FLOWCHARTS Continued**Cable Pull**Group 1

EBCE-1-4-08-LU-1-12-LU-1
EBTC-4-08-1/EBTM-4-08-2.0-S-RA-1
4 Assemblies
RA - 0°

Step	Description
1.	Cable Pull ⁽¹⁾

Group 2

EBCE-1-4-08-LU-1-12-LU-1
EBTC-4-08-1/EBTM-4-08-2.0-S-RA-1
4 Assemblies
RA - 90° Lateral

Step	Description
1.	Cable Pull ⁽¹⁾

Group 3

EBCE-1-4-08-LU-1-12-LU-1
EBTC-4-08-1/EBTM-4-08-2.0-S-RA-1
4 Assemblies
RA- 90° Vertical

Step	Description
1.	Cable Pull ⁽¹⁾

(1) Cable Pull = EIA-364-38

Measure and Record Force Required to Failure
Failure = Discontinuity >1 microsecond at 10 ohms

Cable PullGroup 1

EBCE-1-6-08-LU-1-12-LU-1
EBTC-6-08-1/EBTM-6-08-2.0-S-RA-1
4 Assemblies
RA - 0°

Step	Description
1.	Cable Pull ⁽¹⁾

Group 2

EBCE-1-6-08-LU-1-12-LU-1
EBTC-6-08-1/EBTM-6-08-2.0-S-RA-1
4 Assemblies
RA - 90° Lateral

Step	Description
1.	Cable Pull ⁽¹⁾

Group 3

EBCE-1-6-08-LU-1-12-LU-1
EBTC-6-08-1/EBTM-6-08-2.0-S-RA-1
4 Assemblies
RA- 90° Vertical

Step	Description
1.	Cable Pull ⁽¹⁾

(1) Cable Pull = EIA-364-38

Measure and Record Force Required to Failure
Failure = Discontinuity >1 microsecond at 10 ohms

FLOWCHARTS Continued**Cable Flex**

Note: Test Voltage taken from Samtec Website (standard EBCF)

Note: IR/DWV to be measured on pin-to-pin, row-to-row, and pin-to-ground

Group 1

EBCE-1-4-08-LU-1-16-LU-1

EBTC-4-08-1/EBTM-4-08-2.0-S-RA-1

8 Assemblies

Circular Cable

Step	Description
1.	IR ⁽³⁾
2.	DWV at Test Voltage ⁽²⁾ Test Voltage = 398 V
3.	Cable Flex ⁽¹⁾
4.	Visual Inspection
5.	IR ⁽³⁾
6.	DWV at Test Voltage ⁽²⁾ Test Voltage = 398 V
7.	Rotate Cable 90°
8.	Cable Flex ⁽¹⁾
9.	Visual Inspection
10.	IR ⁽³⁾
11.	DWV at Test Voltage ⁽²⁾ Test Voltage = 398 V

(1) Cable Flex = EIA-364-41

Circular Jacket Cable - to be tested 90° each direction (180° total)

Flat Cable - to be tested 70° each direction (140° total)

Monitor continuity during flex testing

Failure = Discontinuity >1 microsecond at 10 ohms

(2) DWV at Test Voltage = EIA-364-20

Test Condition = 1 (Sea Level)

DWV test voltage is equal to 75% of the lowest breakdown voltage

Test voltage applied for 60 seconds

(3) IR = EIA-364-21

Test Condition = 500 Vdc, 2 Minutes Max

FLOWCHARTS Continued**Cable Flex**

Note: IR/DWV to be measured on pin-to-pin, row-to-row, and pin-to-ground

Note: Test Voltage taken from Samtec Website (standard EBCF)

Group 1

EBCE-1-6-08-LU-1-16-LU-1

EBTC-6-08-1/EBTM-6-08-2.0-S-RA-1

8 Assemblies

Circular Cable

Step	Description
1.	IR ⁽³⁾
2.	DWV at Test Voltage ⁽²⁾ Test Voltage = 398 V
3.	Cable Flex ⁽¹⁾
4.	Visual Inspection
5.	IR ⁽³⁾
6.	DWV at Test Voltage ⁽²⁾ Test Voltage = 398 V
7.	Rotate Cable 90°
8.	Cable Flex ⁽¹⁾
9.	Visual Inspection
10.	IR ⁽³⁾
11.	DWV at Test Voltage ⁽²⁾ Test Voltage = 398 V

(1) Cable Flex = EIA-364-41

Circular Jacket Cable - to be tested 90° each direction (180° total)

Flat Cable - to be tested 70° each direction (140° total)

Monitor continuity during flex testing

Failure = Discontinuity >1 microsecond at 10 ohms

(2) DWV at Test Voltage = EIA-364-20

Test Condition = 1 (Sea Level)

DWV test voltage is equal to 75% of the lowest breakdown voltage

Test voltage applied for 60 seconds

(3) IR = EIA-364-21

Test Condition = 500 Vdc, 2 Minutes Max

FLOWCHARTS Continued**Latch Retention**Group 1

EBCE-1-4-08-LU-1-12-LU-1

EBTC-4-08-1/EBTM-4-08-2.0-S-RA-1

4 Assemblies

Samtec VS Samtec

Step Description

1. Cable Pull ⁽¹⁾ - Non Standard
*Note: Pull cable with up to 50 lbs of pull force or until latch fails.
Record result*

(1) Cable Pull = Other
Cable Pull

Latch RetentionGroup 1

EBCE-1-6-08-LU-1-12-LU-1

EBTC-6-08-1/EBTM-6-08-2.0-S-RA-1

4 Assemblies

Samtec VS Samtec

Step Description

1. Cable Pull ⁽¹⁾ - Non Standard
*Note: Pull cable with up to 50 lbs of pull force or until latch fails.
Record result*

(1) Cable Pull = Other
Cable Pull

ATTRIBUTE DEFINITIONS

The following is a brief, simplified description of attributes.

THERMAL SHOCK:

- 1) EIA-364-32, *Thermal Shock (Temperature Cycling) Test Procedure for Electrical Connectors*.
- 2) Test Condition I: -40°C to +85°C
- 3) Test Time: ½ hour dwell at each temperature extreme
- 4) Number of Cycles: 100
- 5) All test samples are pre-conditioned at ambient.
- 6) All test samples are exposed to environmental stressing in mated conditions.

HUMIDITY:

- 1) Reference document: EIA-364-31, *Humidity Test Procedure for Electrical Connectors*.
- 2) Test Condition B, 240 Hours.
- 3) Method III, +25° C to + 65° C, 90% to 98% Relative Humidity excluding sub-cycles 7a and 7b.
- 4) All samples are pre-conditioned at ambient.
- 5) All test samples are exposed to environmental stressing in mated conditions.

MECHANICAL SHOCK (Specified Pulse):

- 1) Reference document: EIA-364-27, *Mechanical Shock Test Procedure for Electrical Connectors*
- 2) Test Condition H
- 3) Peak Value: 30 G
- 4) Duration: 11 Milliseconds
- 5) Wave Form: Half Sine
- 6) Velocity: 12.3 ft/s
- 7) Number of Shocks: 3 Shocks / Direction, 3 Axis (18 Total)

VIBRATION:

- 1) Reference document: EIA-364-28, *Vibration Test Procedure for Electrical Connectors*
- 2) Test Condition VII, Letter D
- 3) Power Spectral Density: 0.10 G² / Hz
- 4) G 'RMS': 3.1
- 5) Frequency: 50 to 2000 Hz
- 6) Duration: 2.0 Hours per axis (3 axis total)

NANOSECOND-EVENT DETECTION:

- 1) Reference document: EIA-364-87, *Nanosecond-Event Detection for Electrical Connectors*
- 2) Prior to test, the samples were characterized to ensure the low nanosecond event being monitored will trigger the detector.
- 3) After characterization it was determined the test samples could be monitored for 50 nanosecond events

MATING/UNMATING:

- 1) Reference document: EIA-364-13, *Mating and Unmating Forces Test Procedure for Electrical Connectors*.
- 2) The full insertion position was to within 0.003" to 0.004" of the plug bottoming out in the receptacle to prevent damage to the system under test.
- 3) One of the mating parts is secured to a floating X-Y table to prevent damage during cycling.

ATTRIBUTE DEFINITIONS Continued

The following is a brief, simplified description of attributes

NORMAL FORCE (FOR CONTACTS TESTED IN THE HOUSING):

- 1) Reference document: EIA-364-04, *Normal Force Test Procedure for Electrical Connectors*.
- 2) The contacts shall be tested in the connector housing.
- 3) If necessary, a "window" shall be made in the connector body to allow a probe to engage and deflect the contact at the same attitude and distance (plus 0.05 mm [0.002"]) as would occur in actual use.
- 4) The connector housing shall be placed in a holding fixture that does not interfere with or otherwise influence the contact force or deflection.
- 5) Said holding fixture shall be mounted on a floating, adjustable, X-Y table on the base of the Dillon TC², computer-controlled test stand with a deflection measurement system accuracy of 5.0 μm (0.0002").
- 6) The nominal deflection rate shall be 5 mm (0.2")/minute.
- 7) Unless otherwise noted a minimum of five contacts shall be tested.
- 8) The force/deflection characteristic to load and unload each contact shall be repeated five times.
- 9) The system should utilize the TC² software in order to acquire and record the test data.
- 10) The permanent set of each contact shall be measured within the TC² software.
- 11) The acquired data shall be graphed with the deflection data on the X-axis and the force data on the Y-axis and a printout will be stored with the Tracking Code paperwork.

LLCR:

- 1) EIA-364-23, *Low Level Contact Resistance Test Procedure for Electrical Connectors and Sockets*.
- 2) A computer program, *LLCR 221.exe*, ensures repeatability for data acquisition.
- 3) The following guidelines are used to categorize the changes in LLCR as a result of stress
 - a. $\leq +5.0$ mOhms: -----Stable
 - b. +5.1 to +10.0 mOhms: -----Minor
 - c. +10.1 to +15.0 mOhms: -----Acceptable
 - d. +15.1 to +50.0 mOhms: -----Marginal
 - e. +50.1 to +1000 mOhms: -----Unstable
 - f. $>+1000$ mOhms: -----Open Failure

ATTRIBUTE DEFINITIONS Continued

The following is a brief, simplified description of attributes

INSULATION RESISTANCE (IR):

To determine the resistance of insulation materials to leakage of current through or on the surface of these materials when a DC potential is applied.

- 1) PROCEDURE:
 - a. Reference document: EIA-364-21, *Insulation Resistance Test Procedure for Electrical Connectors*.
 - b. Test Conditions:
 - i. Between Adjacent Contacts or Signal-to-Ground
 - ii. Electrification Time 2.0 minutes
 - iii. Test Voltage (500 VDC) corresponds to calibration settings for measuring resistances.
- 2) MEASUREMENTS:
- 3) When the specified test voltage is applied (VDC), the insulation resistance shall not be less than 1000 megohms.

DIELECTRIC WITHSTANDING VOLTAGE (DWV):

To determine if the sockets can operate at their rated voltage and withstand momentary over potential due to switching, surges, and another similar phenomenon. Separate samples are used to evaluate the effect of environmental stresses so not to influence the readings from arcing that occurs during the measurement process.

- 1) PROCEDURE:
 - a. Reference document: EIA-364-20, *Withstanding Voltage Test Procedure for Electrical Connectors*.
 - b. Test Conditions:
 - i. Between Adjacent Contacts or Signal-to-Ground
 - ii. Barometric Test Condition 1
 - iii. Rate of Application 500 V/Sec
 - iv. Test Voltage (VAC) until breakdown occurs
- 2) MEASUREMENTS/CALCULATIONS
 - a. The breakdown voltage shall be measured and recorded.
 - b. The dielectric withstanding voltage shall be recorded as 75% of the minimum breakdown voltage.
 - c. The working voltage shall be recorded as one-third (1/3) of the dielectric withstanding voltage (one-fourth of the breakdown voltage).

ATTRIBUTE DEFINITIONS Continued

The following is a brief, simplified description of attributes

CABLE PULL:

- 1) Secure cable near center and pull-on connector
 - a. At 0°, in-line with cable
 - b. At 90°, in-line with cable
 - c. At 90° Lateral, in-line with cable



Fig. 1

0° Connector pull

CABLE Flex:

- 1) Oscillate and monitor electrical continuity for open circuit indication.
 - a. $\pm 90^\circ$ Flex Mode, bend up to 200 cycles. load on 16 oz.

Fig. 2
(Setup picture)

RESULTS**Mating – Unmating Forces****Mating/Unmating Durability****EBTC-4-08-1 & EBCE-1-4-08-LU-1-12-LU-1**

- **Initial**
 - **Mating**
 - **Min** ----- 9.98 lbs
 - **Max** ----- 10.38 lbs
 - **Unmating**
 - **Min** ----- 6.00 lbs
 - **Max** ----- 6.46 lbs
- **After 25 Cycles**
 - **Mating**
 - **Min** ----- 9.44 lbs
 - **Max** ----- 10.29 lbs
 - **Unmating**
 - **Min** ----- 6.03 lbs
 - **Max** ----- 7.10 lbs
- **After 50 Cycles**
 - **Mating**
 - **Min** ----- 9.55 lbs
 - **Max** ----- 10.53 lbs
 - **Unmating**
 - **Min** ----- 6.81 lbs
 - **Max** ----- 7.95 lbs
- **After 75 Cycles**
 - **Mating**
 - **Min** ----- 9.64 lbs
 - **Max** ----- 11.14 lbs
 - **Unmating**
 - **Min** ----- 7.14 lbs
 - **Max** ----- 8.55 lbs
- **After 100 Cycles**
 - **Mating**
 - **Min** ----- 9.70 lbs
 - **Max** ----- 11.92 lbs
 - **Unmating**
 - **Min** ----- 7.81 lbs
 - **Max** ----- 8.89 lbs
- **After Humidity**
 - **Mating**
 - **Min** ----- 6.54 lbs
 - **Max** ----- 6.94 lbs
 - **Unmating**
 - **Min** ----- 4.77 lbs
 - **Max** ----- 5.30 lbs

RESULTS Continued**EBTC-6-08-1 & EBCE-1-6-08-LU-1-12-LU-1**

- **Initial**
 - **Mating**
 - **Min** -----13.56 lbs
 - **Max** -----14.42 lbs
 - **Unmating**
 - **Min** ----- 8.15 lbs
 - **Max** ----- 8.92 lbs
- **After 25 Cycles**
 - **Mating**
 - **Min** -----13.18 lbs
 - **Max** -----14.60 lbs
 - **Unmating**
 - **Min** ----- 9.14 lbs
 - **Max** -----10.63 lbs
- **After 50 Cycles**
 - **Mating**
 - **Min** -----13.67 lbs
 - **Max** -----14.95 lbs
 - **Unmating**
 - **Min** -----10.18 lbs
 - **Max** -----11.86 lbs
- **After 75 Cycles**
 - **Mating**
 - **Min** -----13.90 lbs
 - **Max** -----15.34 lbs
 - **Unmating**
 - **Min** -----11.00 lbs
 - **Max** -----14.06 lbs
- **After 100 Cycles**
 - **Mating**
 - **Min** -----14.44 lbs
 - **Max** -----15.49 lbs
 - **Unmating**
 - **Min** -----11.49 lbs
 - **Max** -----15.95 lbs
- **After Humidity**
 - **Mating**
 - **Min** ----- 8.79 lbs
 - **Max** ----- 9.03 lbs
 - **Unmating**
 - **Min** ----- 6.76 lbs
 - **Max** ----- 8.63 lbs

RESULTS Continued**Cable Pull force****EBTC-4-08-1 & EBCE-1-4-08-LU-1-12-LU-1**

- **0° Pull**
 - **Min**-----84.00 lbs
 - **Max**-----95.73 lbs
- **90° Pull – Lateral**
 - **Min**-----36.97 lbs
 - **Max**-----48.36 lbs
- **90° Pull - Vertical**
 - **Min**-----67.68 lbs
 - **Max**-----74.25 lbs

EBTC-6-08-1 & EBCE-1-6-08-LU-1-12-LU-1

- **0° Pull**
 - **Min**-----87.48 lbs
 - **Max**-----97.82 lbs
- **90° Pull – Lateral**
 - **Min**-----52.52 lbs
 - **Max**-----53.97 lbs
- **90° Pull - Vertical**
 - **Min**-----122.85 lbs
 - **Max**-----150.84 lbs

Normal Force at 0.0300 inches deflection**EBTC-4-08-01****Group 1**

- **Initial**
 - **Min**-----1668.00 gf **Set ---- 0.0059 inch**
 - **Max**-----1754.40 gf **Set ---- 0.0075 inch**

Group 2

- **Initial**
 - **Min**-----437.60 gf **Set----- 0.0127 inch**
 - **Max**-----605.60 gf **Set----- 0.0163 inch**

EBTC-6-08-01**Group 1**

- **Initial**
 - **Min**-----1386.20 gf **Set ---- 0.0069 inch**
 - **Max**-----1521.00 gf **Set ---- 0.0077 inch**

Group 2

- **Initial**
 - **Min**-----224.30 gf **Set----- 0.0129 inch**
 - **Max**-----263.00 gf **Set----- 0.0150 inch**

Latch Retention**EBTC-4-08-1**

- **Min**-----89.24 lbs
- **Max**-----126.98 lbs

EBTC-6-08-1

- **Min**-----81.39 lbs
- **Max**-----102.84 lbs

RESULTS Continued**Cable Flex:****EBTC-4-08-1 & EBCE-1-4-08-LU-1-16-LU-1****Insulation Resistance minimums, IR****Pin to Pin**

- **Initial**
 - Mated-----45000 Meg Ω ----- Passed
- **After 100 flex cycles**
 - Mated-----45000 Meg Ω ----- Passed
- **After 200 flex cycles**
 - Mated-----45000 Meg Ω ----- Passed

Row to Row

- **Initial**
 - Mated-----45000 Meg Ω ----- Passed
- **After 100 flex cycles**
 - Mated-----45000 Meg Ω ----- Passed
- **After 200 flex cycles**
 - Mated-----45000 Meg Ω ----- Passed

Pin to Ground

- **Initial**
 - Mated-----45000 Meg Ω ----- Passed
- **After 100 flex cycles**
 - Mated-----45000 Meg Ω ----- Passed
- **After 200 flex cycles**
 - Mated-----45000 Meg Ω ----- Passed

Dielectric Withstanding Voltage minimums, DWV

- Test Voltage-----398 VAC

Pin to Pin

- **Initial DWV**-----Passed
- **After 100 Flex cycles DWV**-----Passed
- **After 200 Flex cycles DWV**-----Passed

Row to Row

- **Initial DWV**-----Passed
- **After 100 Flex cycles DWV**-----Passed
- **After 200 Flex cycles DWV**-----Passed

Pin to Ground

- **Initial DWV**-----Passed
- **After 100 Flex cycles DWV**-----Passed
- **After 200 Flex cycles DWV**-----Passed

RESULTS Continued**EBTC-6-08-1 & EBCE-1-6-08-LU-1-16-LU-1****Insulation Resistance minimums, IR****Pin to Pin**

- **Initial**
 - Mated-----45000 Meg Ω ----- Passed
- **After 100 flex cycles**
 - Mated-----45000 Meg Ω ----- Passed
- **After 200 flex cycles**
 - Mated-----45000 Meg Ω ----- Passed

Row to Row

- **Initial**
 - Mated-----45000 Meg Ω ----- Passed
- **After 100 flex cycles**
 - Mated-----45000 Meg Ω ----- Passed
- **After 200 flex cycles**
 - Mated-----45000 Meg Ω ----- Passed

Pin to Ground

- **Initial**
 - Mated-----45000 Meg Ω ----- Passed
- **After 100 flex cycles**
 - Mated-----45000 Meg Ω ----- Passed
- **After 200 flex cycles**
 - Mated-----45000 Meg Ω ----- Passed

Dielectric Withstanding Voltage minimums, DWV

- Test Voltage -----398 VAC

Pin to Pin

- **Initial DWV** -----Passed
- **After 100 Flex cycles DWV** -----Passed
- **After 200 Flex cycles DWV** -----Passed

Row to Row

- **Initial DWV** -----Passed
- **After 100 Flex cycles DWV** -----Passed
- **After 200 Flex cycles DWV** -----Passed

Pin to Ground

- **Initial DWV** -----Passed
- **After 100 Flex cycles DWV** -----Passed
- **After 200 Flex cycles DWV** -----Passed

RESULTS Continued**LLCR Durability (216 Signal, 24 ground LLCR test points)****EBTC-4-08-1 & EBCE-1-4-08-LU-1-12-LU-1****Signal**

- Initial -----385.10 mOhms Max

Ground

- Initial ----- 28.35 mOhms Max
- Durability, 25 Cycles
 - <= +5.0 mOhms-----240 Points ----- Stable
 - +5.1 to +10.0 mOhms-----0 Points ----- Minor
 - +10.1 to +15.0 mOhms -----0 Points ----- Acceptable
 - +15.1 to +50.0 mOhms -----0 Points ----- Marginal
 - +50.1 to +1000 mOhms-----0 Points ----- Unstable
 - >+1000 mOhms-----0 Points ----- Open Failure
- Thermal
 - <= +5.0 mOhms-----223 Points ----- Stable
 - +5.1 to +10.0 mOhms ----- 17 Points ----- Minor
 - +10.1 to +15.0 mOhms -----0 Points ----- Acceptable
 - +15.1 to +50.0 mOhms -----0 Points ----- Marginal
 - +50.1 to +1000 mOhms-----0 Points ----- Unstable
 - >+1000 mOhms-----0 Points ----- Open Failure
- Humidity
 - <= +5.0 mOhms-----239 Points ----- Stable
 - +5.1 to +10.0 mOhms ----- 1 Points ----- Minor
 - +10.1 to +15.0 mOhms -----0 Points ----- Acceptable
 - +15.1 to +50.0 mOhms -----0 Points ----- Marginal
 - +50.1 to +1000 mOhms-----0 Points ----- Unstable
 - >+1000 mOhms-----0 Points ----- Open Failure

LLCR Durability (312 Signal, 24 ground LLCR test points)**EBTC-6-08-1 & EBCE-1-6-08-LU-1-12-LU-1****Signal**

- Initial -----437.40 mOhms Max

Ground

- Initial ----- 23.52 mOhms Max
- Durability, 25 Cycles
 - <= +5.0 mOhms-----335 Points ----- Stable
 - +5.1 to +10.0 mOhms ----- 1 Points ----- Minor
 - +10.1 to +15.0 mOhms -----0 Points ----- Acceptable
 - +15.1 to +50.0 mOhms -----0 Points ----- Marginal
 - +50.1 to +1000 mOhms-----0 Points ----- Unstable
 - >+1000 mOhms-----0 Points ----- Open Failure
- Thermal
 - <= +5.0 mOhms-----308 Points ----- Stable
 - +5.1 to +10.0 mOhms ----- 27 Points ----- Minor
 - +10.1 to +15.0 mOhms ----- 1 Points ----- Acceptable
 - +15.1 to +50.0 mOhms -----0 Points ----- Marginal
 - +50.1 to +1000 mOhms-----0 Points ----- Unstable
 - >+1000 mOhms-----0 Points ----- Open Failure
- Humidity
 - <= +5.0 mOhms-----318 Points ----- Stable
 - +5.1 to +10.0 mOhms ----- 18 Points ----- Minor
 - +10.1 to +15.0 mOhms -----0 Points ----- Acceptable
 - +15.1 to +50.0 mOhms -----0 Points ----- Marginal
 - +50.1 to +1000 mOhms-----0 Points ----- Unstable
 - >+1000 mOhms-----0 Points ----- Open Failure

RESULTS Continued**LLCR Shock & Vibration (256 signal 1, 32 signal 2, 32 ground LLCR test points)**

EBTC-4-08-1 & EBCE-1-4-08-LU-1-12-LU-1

Signal 1

- Initial-----387.24 mOhms Max

Signal 2

- Initial-----319.24 mOhms Max

Ground

- Initial-----26.78 mOhms Max

- Shock & Vibration

- <= +5.0 mOhms-----310 Points-----Stable
- +5.1 to +10.0 mOhms-----10 Points-----Minor
- +10.1 to +15.0 mOhms-----0 Points-----Acceptable
- +15.1 to +50.0 mOhms-----0 Points-----Marginal
- +50.1 to +1000 mOhms-----0 Points-----Unstable
- >+1000 mOhms-----0 Points-----Open Failure

Mechanical Shock & Random Vibration:

- Shock
 - No Damage-----Pass
 - 50 Nanoseconds-----Pass
- Vibration
 - No Damage-----Pass
 - 50 Nanoseconds-----Pass

LLCR Shock & Vibration (192 signal 1, 16 signal 2, 192 signal 3, 16 signal 4, 32 ground LLCR test points)

EBTC-6-08-1 & EBCE-1-6-08-LU-1-12-LU-1

Signal 1

- Initial-----497.21 mOhms Max

Signal 2

- Initial-----415.45 mOhms Max

Signal 3

- Initial-----398.96 mOhms Max

Signal 4

- Initial-----319.76 mOhms Max

Ground

- Initial-----21.12 mOhms Max

- Shock & Vibration

- <= +5.0 mOhms-----443 Points-----Stable
- +5.1 to +10.0 mOhms-----5 Points-----Minor
- +10.1 to +15.0 mOhms-----0 Points-----Acceptable
- +15.1 to +50.0 mOhms-----0 Points-----Marginal
- +50.1 to +1000 mOhms-----0 Points-----Unstable
- >+1000 mOhms-----0 Points-----Open Failure

Mechanical Shock & Random Vibration:

- Shock
 - No Damage-----Pass
 - 50 Nanoseconds-----Pass
- Vibration
 - No Damage-----Pass
 - 50 Nanoseconds-----Pass

DATA SUMMARIES**MATING/UNMATING:****Mating/Unmating Durability Group****EBTC-4-08-1 & EBCE-1-4-08-LU-1-12-LU-1**

	Initial				After 25 Cycles			
	Mating		Unmating		Mating		Unmating	
	Newton's	Force (Lbs)	Newton's	Force (Lbs)	Newton's	Force (Lbs)	Newton's	Force (Lbs)
Minimum	44.39	9.98	26.69	6.00	41.99	9.44	26.82	6.03
Maximum	46.17	10.38	28.73	6.46	45.77	10.29	31.58	7.10
Average	45.15	10.15	27.40	6.16	43.29	9.73	28.90	6.50
St Dev	0.92	0.21	1.16	0.26	2.15	0.48	2.44	0.55
Count	3	3	3	3	3	3	3	3
	After 50 Cycles				After 75 Cycles			
	Mating		Unmating		Mating		Unmating	
	Newton's	Force (Lbs)	Newton's	Force (Lbs)	Newton's	Force (Lbs)	Newton's	Force (Lbs)
Minimum	42.48	9.55	30.29	6.81	42.88	9.64	31.76	7.14
Maximum	46.84	10.53	35.36	7.95	49.55	11.14	38.03	8.55
Average	44.05	9.90	32.11	7.22	45.16	10.15	35.01	7.87
St Dev	2.42	0.54	2.82	0.63	3.80	0.85	3.14	0.71
Count	3	3	3	3	3	3	3	3
	After 100 Cycles				After Humidity			
	Mating		Unmating		Mating		Unmating	
	Newton's	Force (Lbs)	Newton's	Force (Lbs)	Newton's	Force (Lbs)	Newton's	Force (Lbs)
Minimum	43.15	9.70	34.74	7.81	29.09	6.54	21.22	4.77
Maximum	53.02	11.92	39.54	8.89	30.87	6.94	23.57	5.30
Average	46.45	10.44	37.91	8.52	30.19	6.79	22.25	5.00
St Dev	5.69	1.28	2.75	0.62	0.96	0.22	1.20	0.27
Count	3	3	3	3	3	3	3	3

DATA SUMMARIES Continued**EBTC-6-08-1 & EBCE-1-6-08-LU-1-12-LU-1**

	Initial				After 25 Cycles			
	Mating		Unmating		Mating		Unmating	
	Newton's	Force (Lbs)	Newton's	Force (Lbs)	Newton's	Force (Lbs)	Newton's	Force (Lbs)
Minimum	60.31	13.56	36.25	8.15	58.62	13.18	40.65	9.14
Maximum	64.14	14.42	39.68	8.92	64.94	14.60	47.28	10.63
Average	61.63	13.86	38.48	8.65	61.53	13.83	44.17	9.93
St Dev	2.17	0.49	1.93	0.43	3.19	0.72	3.33	0.75
Count	3	3	3	3	3	3	3	3
	After 50 Cycles				After 75 Cycles			
	Mating		Unmating		Mating		Unmating	
	Newton's	Force (Lbs)	Newton's	Force (Lbs)	Newton's	Force (Lbs)	Newton's	Force (Lbs)
Minimum	60.80	13.67	45.28	10.18	61.83	13.90	48.93	11.00
Maximum	66.50	14.95	52.75	11.86	68.23	15.34	62.54	14.06
Average	63.10	14.19	48.39	10.88	64.54	14.51	55.04	12.37
St Dev	3.00	0.67	3.89	0.87	3.31	0.74	6.91	1.55
Count	3	3	3	3	3	3	3	3
	After 100 Cycles				After Humidity			
	Mating		Unmating		Mating		Unmating	
	Newton's	Force (Lbs)	Newton's	Force (Lbs)	Newton's	Force (Lbs)	Newton's	Force (Lbs)
Minimum	64.23	14.44	51.11	11.49	39.10	8.79	30.07	6.76
Maximum	68.90	15.49	70.95	15.95	40.17	9.03	38.39	8.63
Average	66.01	14.84	60.70	13.65	39.54	8.89	34.07	7.66
St Dev	2.53	0.57	9.94	2.23	0.56	0.12	4.17	0.94
Count	3	3	3	3	3	3	3	3

DATA SUMMARIES Continued**NORMAL FORCE (FOR CONTACTS TESTED OUTSIDE THE HOUSING):**

- 1) Calibrated force gauges are used along with computer-controlled positioning equipment.
- 2) Typically, 8-10 readings are taken and the averages are reported.

EBTC-4-08-01**Group 1**

Initial	Deflections in inches Forces in Grams										
	0.0030	0.0060	0.0090	0.0120	0.0150	0.0180	0.0210	0.0240	0.0270	0.0300	<i>SET</i>
Averages	103.19	259.70	466.79	664.51	838.94	1016.00	1182.70	1368.11	1545.53	1711.94	0.0065
Min	80.80	227.60	418.90	618.30	800.70	979.90	1139.80	1323.90	1493.20	1668.00	0.0059
Max	124.60	297.00	518.30	713.70	888.20	1067.80	1237.10	1431.80	1613.50	1754.40	0.0075
St. Dev	14.408	22.466	27.653	26.282	25.380	25.690	27.538	30.252	34.548	26.022	0.0005
Count	10	10	10	10	10	10	10	10	10	10	10

Group 2

Initial	Deflections in inches Forces in Grams										
	0.0030	0.0060	0.0090	0.0120	0.0150	0.0180	0.0210	0.0240	0.0270	0.0300	<i>SET</i>
Averages	36.49	70.31	94.62	117.02	136.93	155.33	171.99	188.96	204.35	544.28	0.0143
Min	30.20	60.60	84.20	103.80	124.60	141.40	158.40	174.80	188.80	437.60	0.0127
Max	63.40	103.30	127.80	159.70	183.60	206.20	221.00	239.80	258.20	605.60	0.0163
St. Dev	8.865	12.312	14.285	17.889	19.599	22.087	22.416	23.124	24.929	45.913	0.0009
Count	12	12	12	12	12	12	12	12	12	12	12

EBTC-6-08-01**Group 1**

Initial	Deflections in inches Forces in Grams										
	0.0030	0.0060	0.0090	0.0120	0.0150	0.0180	0.0210	0.0240	0.0270	0.0300	<i>SET</i>
Averages	134.38	331.57	537.52	729.24	854.31	985.13	1106.83	1235.51	1352.63	1456.94	0.0073
Min	110.00	291.70	470.20	681.10	817.30	946.10	1059.40	1190.80	1300.50	1386.20	0.0069
Max	204.80	418.80	632.90	788.50	915.80	1050.50	1171.90	1305.20	1423.10	1521.00	0.0077
St. Dev	24.867	32.341	40.307	28.644	28.491	32.007	34.835	35.273	38.493	44.062	0.0002
Count	12	12	12	12	12	12	12	12	12	12	12

Group 2

Initial	Deflections in inches Forces in Grams										
	0.0030	0.0060	0.0090	0.0120	0.0150	0.0180	0.0210	0.0240	0.0270	0.0300	<i>SET</i>
Averages	40.30	79.54	110.78	136.52	156.64	176.37	193.31	210.47	225.11	236.19	0.0139
Min	33.30	70.40	102.00	126.70	146.40	167.10	183.90	199.50	217.60	224.30	0.0129
Max	45.30	90.90	123.30	151.00	173.80	194.80	210.70	229.90	246.70	263.00	0.0150
St. Dev	3.886	6.046	6.386	6.901	7.502	8.596	8.843	9.738	9.885	12.425	0.0006
Count	12	12	12	12	12	12	12	12	12	12	12

DATA SUMMARIES Continued**Cable Pull Force:****EBTC-4-08-1 & EBCE-1-4-08-LU-1-12-LU-1****0° Pull**

	Force (lbs)
Minimum	84.00
Maximum	95.73
Average	89.38

90° Pull - Lateral

	Force (lbs)
Minimum	36.97
Maximum	48.36
Average	41.48

90° Pull - Vertical

	Force (lbs)
Minimum	67.68
Maximum	74.25
Average	70.72

EBTC-6-08-1 & EBCE-1-6-08-LU-1-12-LU-1**0° Pull**

	Force (lbs)
Minimum	87.48
Maximum	97.82
Average	93.41

90° Pull - Lateral

	Force (lbs)
Minimum	52.52
Maximum	53.97
Average	53.41

90° Pull - Vertical

	Force (lbs)
Minimum	122.85
Maximum	150.84
Average	137.73

DATA SUMMARIES Continued**Latch Retention:
EBTC-4-08-1**

	Force (lbs)
Minimum	89.24
Maximum	126.98
Average	109.12

EBTC-6-08-1

	Force (lbs)
Minimum	81.39
Maximum	102.84
Average	88.44

DATA SUMMARIES Continued**Cable Flex:**

EBTC-4-08-1 & EBCE-1-4-08-LU-1-16-LU-1

Insulation Resistance minimums, IR

Pin to Pin	
Mated	
Minimum	
Initial	45000
After 100 Flex Cycles	45000
After 200 Flex Cycles	45000

Row to Row	
Mated	
Minimum	
Initial	45000
After 100 Flex Cycles	45000
After 200 Flex Cycles	45000

Pin to Ground	
Mated	
Minimum	
Initial	45000
After 100 Flex Cycles	45000
After 200 Flex Cycles	45000

Dielectric Withstanding Voltage minimums, DWV

Voltage Rating Summary	
Minimum	EBTC\EBCE
Test Voltage	398

Pin to Pin	
Initial Test Voltage	Passed
After 100 Flex Cycles Test Voltage	Passed
After 200 Flex Cycles Test Voltage	Passed

Row to Row	
Initial Test Voltage	Passed
After 100 Flex Cycles Test Voltage	Passed
After 200 Flex Cycles Test Voltage	Passed

Pin to Ground	
Initial Test Voltage	Passed
After 100 Flex Cycles Test Voltage	Passed
After 200 Flex Cycles Test Voltage	Passed

DATA SUMMARIES Continued**EBTC-6-08-1 & EBCE-1-6-08-LU-1-16-LU-1****Insulation Resistance minimums, IR**

Pin to Pin	
Mated	
Minimum	
Initial	45000
After 100 Flex Cycles	45000
After 200 Flex Cycles	45000

Row to Row	
Mated	
Minimum	
Initial	45000
After 100 Flex Cycles	45000
After 200 Flex Cycles	45000

Pin to Ground	
Mated	
Minimum	
Initial	45000
After 100 Flex Cycles	45000
After 200 Flex Cycles	45000

Dielectric Withstanding Voltage minimums, DWV

Voltage Rating Summary	
Minimum	EBTC\EBCE
Test Voltage	398

Pin to Pin	
Initial Test Voltage	Passed
After 100 Flex Cycles Test Voltage	Passed
After 200 Flex Cycles Test Voltage	Passed

Row to Row	
Initial Test Voltage	Passed
After 100 Flex Cycles Test Voltage	Passed
After 200 Flex Cycles Test Voltage	Passed

Pin to Ground	
Initial Test Voltage	Passed
After 100 Flex Cycles Test Voltage	Passed
After 200 Flex Cycles Test Voltage	Passed

DATA SUMMARIES Continued

LLCR Durability:

- 1) A total of 216 signals, and 24 ground points were measured.
- 2) EIA-364-23, *Low Level Contact Resistance Test Procedure for Electrical Connectors and Sockets*.
- 3) A computer program, *LLCR 221.exe*, ensures repeatability for data acquisition.
- 4) The following guidelines are used to categorize the changes in LLCR as a result of stress.
 - a. $\leq +5.0$ mOhms: -----Stable
 - b. $+5.1$ to $+10.0$ mOhms: -----Minor
 - c. $+10.1$ to $+15.0$ mOhms: -----Acceptable
 - d. $+15.1$ to $+50.0$ mOhms: -----Marginal
 - e. $+50.1$ to $+1000$ mOhms -----Unstable
 - f. $>+1000$ mOhms: -----Open Failure

EBTC-4-08-1 & EBCE-1-4-08-LU-1-12-LU-1

LLCR Measurement Summaries by Pin Type				
Date	2024/9/2	2024/9/5	2024/7/31	2024/8/13
Room Temp (Deg C)	22	22	22	22
Rel Humidity (%)	55	55	55	55
Technician	Kason He	Kason He	Kason He	Kason He
mOhm values				
Actual	Delta	Delta	Delta	Delta
Initial	100 Cycles	Therm Shck	Humidity	
Pin Type: Signal 1				
Average	346.6	2.5	1.6	1.6
St. Dev.	16.9	0.8	1.5	0.9
Min	297.7	0.5	0	0.0
Max	385.1	4.3	7.3	6.1
Summary Count	216	216	216	216
Total Count	216	216	216	216
Pin Type: Ground 1				
Average	26.93	1.26	2.00	2.03
St. Dev.	0.91	1.17	1.60	1.33
Min	24.91	0.01	0.23	0.01
Max	28.35	4.06	5.75	4.87
Summary Count	24	24	24	24
Total Count	24	24	24	24

LLCR Delta Count by Category						
	Stable	Minor	Acceptable	Marginal	Unstable	Open
mOhms	≤ 5	$>5 \ \& \ \leq 10$	$>10 \ \& \ \leq 15$	$>15 \ \& \ \leq 50$	$>50 \ \& \ \leq 1000$	>1000
100 Cycles	240	0	0	0	0	0
Therm Shck	223	17	0	0	0	0
Humidity	239	1	0	0	0	0

DATA SUMMARIES Continued

LLCR Durability:

- 1) A total of 312 signals, and 24 ground points were measured.
- 2) EIA-364-23, *Low Level Contact Resistance Test Procedure for Electrical Connectors and Sockets*.
- 3) A computer program, *LLCR 221.exe*, ensures repeatability for data acquisition.
- 4) The following guidelines are used to categorize the changes in LLCR as a result of stress.
 - a. $\leq +5.0$ mOhms: -----Stable
 - b. $+5.1$ to $+10.0$ mOhms: -----Minor
 - c. $+10.1$ to $+15.0$ mOhms: -----Acceptable
 - d. $+15.1$ to $+50.0$ mOhms: -----Marginal
 - e. $+50.1$ to $+1000$ mOhms -----Unstable
 - f. $>+1000$ mOhms: -----Open Failure

EBTC-6-08-1 & EBCE-1-6-08-LU-1-12-LU-1

LLCR Measurement Summaries by Pin Type				
Date	7/17/2024	7/22/2024	2024/7/31	2024/8/13
Room Temp (Deg C)	22	22	22	22
Rel Humidity (%)	55	55	55	55
Technician	Kason He	Kason He	Kason He	Kason He
mOhm values				
	Actual	Delta	Delta	Delta
	Initial	100 Cycles	Therm Shck	Humidity
Pin Type: Signal 1				
Average	344.7	1.2	1.8	1.5
St. Dev.	38.2	1.1	1.9	1.6
Min	79.65	0	0	0.0
Max	437.4	9.3	12.3	8.6
Summary Count	312	312	312	312
Total Count	312	312	312	312
Pin Type: Ground 1				
Average	21.23	1.04	1.48	0.99
St. Dev.	0.92	1.08	0.99	0.65
Min	19.93	0.02	0.06	0.05
Max	23.52	4.46	3.37	2.14
Summary Count	24	24	24	24
Total Count	24	24	24	24

LLCR Delta Count by Category						
	Stable	Minor	Acceptable	Marginal	Unstable	Open
mOhms	≤ 5	$>5 \ \& \ \leq 10$	$>10 \ \& \ \leq 15$	$>15 \ \& \ \leq 50$	$>50 \ \& \ \leq 1000$	>1000
100 Cycles	335	1	0	0	0	0
Therm Shck	308	27	1	0	0	0
Humidity	318	18	0	0	0	0

DATA SUMMARIES Continued

LLCR Shock & Vibration:

- 1). A total of 256 signal 1, 32 signal 2, 32 ground points were measured.
- 2). EIA-364-23, *Low Level Contact Resistance Test Procedure for Electrical Connectors and Sockets*.
- 3). The following guidelines are used to categorize the changes in LLCR as a result of stress.
 - a. $\leq +5.0$ mOhms: -----Stable
 - b. $+5.1$ to $+10.0$ mOhms: -----Minor
 - c. $+10.1$ to $+15.0$ mOhms: -----Acceptable
 - d. $+15.1$ to $+50.0$ mOhms: -----Marginal
 - e. $+50.1$ to $+1000$ mOhms -----Unstable
 - f. $>+1000$ mOhms:-----Open Failure

EBTC-4-08-1 & EBCE-1-4-08-LU-1-12-LU-1

LLCR Measurement Summaries by Pin Type		
Date	2025/6/16	2025/6/18
Room Temp (Deg C)	22	22
Rel Humidity (%)	56	55
Technician	Brian Stemle	Brian Stemle
mOhm values	Actual	Delta
	Initial	Shock-Vib
Pin Type: Signal 1		
Average	368.39	2.11
St. Dev.	6.73	0.56
Min	354.79	1.15
Max	387.24	4.31
Summary Count	256	256
Total Count	256	256
Pin Type: Signal 2		
Average	308.29	1.81
St. Dev.	4.22	0.42
Min	300.71	1.15
Max	319.24	2.84
Summary Count	32	32
Total Count	32	32
Pin Type: GND 1		
Average	21.06	3.58
St. Dev.	3.78	2.62
Min	12.74	0.2
Max	26.78	9.23
Summary Count	32	32
Total Count	32	32

LLCR Delta Count by Category						
	Stable	Minor	Acceptable	Marginal	Unstable	Open
mOhms	≤ 5	$>5 \ \& \ \leq 10$	$>10 \ \& \ \leq 15$	$>15 \ \& \ \leq 50$	$>50 \ \& \ \leq 1000$	>1000
Shock-Vib	310	10	0	0	0	0

DATA SUMMARIES Continued**Nanosecond Event Detection:**

Shock and Vibration Event Detection Summary	
Contacts tested	60
Test Condition	H, 30g's, 11ms, Half-Sine
Shock Events	0
Test Condition	VII-D, 3.1 rms g
Vibration Events	0
Total Events	0

DATA SUMMARIES Continued

LLCR Shock & Vibration:

- 1). A total of 192 signal 1, 16 signal 2, 192 signal 3, 16 signal 4, 32 ground points were measured.
- 2). EIA-364-23, *Low Level Contact Resistance Test Procedure for Electrical Connectors and Sockets*.
- 3). The following guidelines are used to categorize the changes in LLCR as a result of stress.
 - a. $\leq +5.0$ mOhms: -----Stable
 - b. $+5.1$ to $+10.0$ mOhms: -----Minor
 - c. $+10.1$ to $+15.0$ mOhms: -----Acceptable
 - d. $+15.1$ to $+50.0$ mOhms: -----Marginal
 - e. $+50.1$ to $+1000$ mOhms -----Unstable
 - f. $>+1000$ mOhms:-----Open Failure

EBTC-6-08-1 & EBCE-1-6-08-LU-1-12-LU-1

LLCR Measurement Summaries by Pin Type		
Date	2025/11/20	2025/11/24
Room Temp (Deg C)	22	22
Rel Humidity (%)	44	42
Technician	Daniel Haydon	Daniel Haydon
mOhm values	Actual	Delta
	Initial	Shock-Vib
Pin Type: Signal 1		
Average	468.98	0.64
St. Dev.	9.85	0.69
Min	451.24	0.01
Max	497.21	4.51
Summary Count	192	192
Total Count	192	192
Pin Type: Signal 2		
Average	407.78	1.34
St. Dev.	5.79	1.45
Min	394.49	0.04
Max	415.45	4.7
Summary Count	16	16
Total Count	16	16
Pin Type: Signal 3		
Average	373	0.61
St. Dev.	9.68	1.05
Min	359.16	0
Max	398.96	9.03
Summary Count	192	192
Total Count	192	192
Pin Type: Signal 4		
Average	313.05	0.63
St. Dev.	4.86	0.47
Min	303.82	0.15

Tracking Code: CR-1119204_Report_Rev_1	Part #: EBTC-4-08-1/EBCE-X-4-08-LU-1-XX-LU-1 EBTC-6-08-1/EBCE-X-6-08-LU-1-XX-LU-1
Part description: EBTC/EBCE	

Max	319.76	1.8
Summary Count	16	16
Total Count	16	16
Pin Type: GND 1		
Average	19.39	1.43
St. Dev.	1.47	1.44
Min	15.33	0.13
Max	21.12	5.73
Summary Count	32	32
Total Count	32	32

LLCR Delta Count by Category						
	Stable	Minor	Acceptable	Marginal	Unstable	Open
mOhms	<=5	>5 & <=10	>10 & <=15	>15 & <=50	>50 & <=1000	>1000
Shock-Vib	443	5	0	0	0	0

Nanosecond Event Detection:

Shock and Vibration Event Detection Summary	
Contacts tested	60
Test Condition	H, 30g's, 11ms, Half-Sine
Shock Events	0
Test Condition	VII-D, 3.1 rms g
Vibration Events	0
Total Events	0

EQUIPMENT AND CALIBRATION SCHEDULES**Equipment #:** HZ-TCT-01**Description:** Normal force analyzer**Manufacturer:** Mecmesin Multitester**Model:** Mecmesin Multitester 2.5-i**Serial #:** 08-1049-04**Accuracy:** Last Cal: 4/26/2025, Next Cal: 4/25/2026**Equipment #:** HZ-THC-01**Description:** Humidity transmitter**Manufacturer:** Thermotron**Model:** SM-8-8200**Serial #:** 38846**Accuracy:** Last Cal: 2/28/2025, Next Cal: 2/27/2026**Equipment #:** HZ-TSC-01**Description:** Vertical Thermal Shock Chamber**Manufacturer:** Cincinnati Sub Zero**Model:** VTS-3-6-6-SC/AC**Serial #:** 10-VT14994**Accuracy:** See Manual

... Last Cal: 06/28/2025, Next Cal: 06/27/2026

Equipment #: HZ-MO-05**Description:** Micro-ohmmeter**Manufacturer:** Keithley**Model:** 3706**Serial #:** 1285188**Accuracy:** Last Cal: 11/15/2025, Next Cal: 11/14/2026**Equipment #:** DG-HPT-01**Description:** Hipot Safety Tester**Manufacturer:** Vitrek**Model:** V73**Serial #:** 025866**Accuracy:**

... Last Cal: 04/16/2025, Next Cal: 04/15/2026

EQUIPMENT AND CALIBRATION SCHEDULES Continued**Equipment #:** SVC-01**Description:** Shock & Vibration Table**Manufacturer:** Data Physics**Model:** LE-DSA-10-20K**Serial #:** 10037**Accuracy:** See Manual

... Last Cal: 04/22/2025, Next Cal: 04/22/2026

Equipment #: ACLM-01**Description:** Accelerometer**Manufacturer:** PCB Piezotronics**Model:** 352C03**Serial #:** 115819**Accuracy:** See Manual

... Last Cal: 07/18/2025, Next Cal: 07/18/2026

Equipment #: ED-03**Description:** Event Detector**Manufacturer:** Analysis Tech**Model:** 32EHD**Serial #:** 1100604**Accuracy:** See Manual

... Last Cal: 10/31/2025, Next Cal: 10/31/2026