

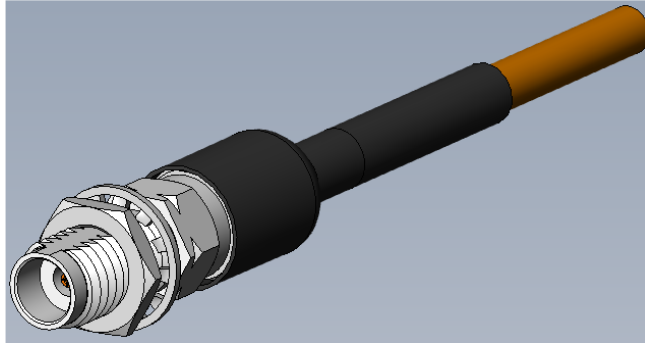

Project Number: Design Qualification Test Report	Tracking Code: CR-1171403_Report_Rev_1
Requested by: Tom Yahav	Date: 11/22/2024
Part #: LL043-24BJ-24BJ-0152	
Part description: LL043	Tech: Kason He
Test Start: 11/11/2024	Test Completed: 11/19/2024



DESIGN QUALIFICATION TEST REPORT
LL043
LL043-24BJ-24BJ-0152

Tracking Code: CR-1171403_Report_Rev_1	Part #: LL043-24BJ-24BJ-0152
Part description: LL043	

REVISION HISTORY

DATA	REV.NUM.	DESCRIPTION	ENG
11/22/2024	1	Initial Issue	KH

Tracking Code: CR-1171403_Report_Rev_1	Part #: LL043-24BJ-24BJ-0152
Part description: LL043	

CERTIFICATION

All instruments and measuring equipment were calibrated to National Institute for Standards and Technology (NIST) traceable standards according to ISO 10012-1 and ANSI/NCSL 2540-1, as applicable.

All contents contained herein are the property of Samtec. No portion of this report, in part or in full shall be reproduced without prior written approval of Samtec.

SCOPE

To perform the following tests: Design Qualification test. Please see test plan.

APPLICABLE DOCUMENTS

Standards: MIL-PRF-39012.

TEST SAMPLES AND PREPARATION

- 1) All materials were manufactured in accordance with the applicable product specification.
- 2) All test samples were identified and encoded to maintain traceability throughout the test sequences.
- 3) Parts not intended for testing LLCR and DWV/IR are visually inspected and cleaned if necessary.
- 4) Any additional preparation will be noted in the individual test sequences.

FLOWCHARTS

IR/DWV

Pin-to-Ground

Group 1

LL043-24BJ-505050-1000

4 Assemblies

Step	Description
1.	Length & Mass
2.	Interface Gaging
3.	IR (2) - Non Standard
4.	DWV at Test Voltage ₍₁₎ - Non Standard Test Voltage = 500 VAC
5.	LLCR (3) - Non Standard <i>Note: Signal and ground.</i>
6.	Thermal Shock (4) - Non Standard
7.	IR (2) - Non Standard
8.	DWV at Test Voltage ₍₁₎ - Non Standard Test Voltage = 500 VAC
9.	LLCR (3) - Non Standard Max Delta = 15 mOhm <i>Note: Signal and ground.</i>
10.	Interface Gaging

-
- (1) DWV at Test Voltage = Other
 Test Condition = 1 (Sea Level) Test voltage applied for 60 seconds
 MIL-PRF-39012, Paragraph. 4.6.14 per MIL-STD-202-301
 - (2) IR = Other
 Test Condition = 500V DC, 2 Minutes Max
 MIL-PRF-39012, Paragraph 4.6.8 per MIL-STD-202-302
 - (3) LLCR = Other
 Open Circuit Voltage = 20 mV Max
 Test Current = 100 mA Max
 MIL-PRF-39012, Paragraph 4.6.13 except current to be 100mA nominal and voltage to be 20 mV maximum.
 - (4) Thermal Shock = Other
 Exposure Time at Temperature Extremes = 1/2 Hour
 Test Condition = I (-65°C to +125°C)
 Test Duration = test condition B except 10 cycles instead of 5.
 MIL-PRF-39012, Paragraph. 4.6.17 per MIL-STD-202-107

FLOWCHARTS Continued

Cable Pull

Group 1
LL043-24BJ-505050-0152

4 Assemblies
0 Degrees

Step	Description
1.	Cable Retention (2) - Non Standard <i>Note: Pull-to-destruct.</i>

Group 2
LL043-24BJ-505050-0152

4 Assemblies
0 Degrees

Step	Description
1.	Length & Mass
2.	Interface Gaging
3.	LLCR (3) - Non Standard <i>Note: Signal and ground.</i>
4.	Cable Retention (1) - Non Standard <i>Note: Apply 15 pounds (6.8 kg) for Cable Retention test.</i>
5.	LLCR (3) - Non Standard <i>Note: Signal and ground.</i>
6.	Interface Gaging

-
- (1) Cable Retention = Other
Apply 15 pounds (6.8 kg) for Cable Retention test.
MIL-PRF-30192, Paragraph 4.6.21
- (2) Cable Retention = Other
Pull-to-destruct.
MIL-PRF-30192, Paragraph 4.6.21
- (3) LLCR = Other
Open Circuit Voltage = 20 mV Max
Test Current = 100 mA Max
MIL-PRF-39012, Paragraph 4.6.13 except current to be 100mA nominal and voltage to be 20 mV maximum.

ATTRIBUTE DEFINITIONS

The following is a brief, simplified description of attributes.

THERMAL SHOCK:

- 1) MIL-PRF-39012, paragraph. 4.6.17 per MIL-STD-202-107.
- 2) Test Condition I: -65°C to +125°C
- 3) Test Time: ½ hour dwell at each temperature extreme
- 4) Test Duration: test condition B except 10 cycles instead of 5.
- 5) All test samples are pre-conditioned at ambient.
- 6) All test samples are exposed to environmental stressing in the mated condition.

LLCR:

- 1) MIL-PRF-39012, Paragraph 4.6.13 except current to be 100 mA nominal and voltage to be 20 mV maximum.
- 2) A computer program, *LLCR 221.exe*, ensures repeatability for data acquisition.
- 3) The following guidelines are used to categorize the changes in LLCR as a result from stressing
 - a. <= +5.0 mOhms: -----Stable
 - b. +5.1 to +10.0 mOhms:-----Minor
 - c. +10.1 to +15.0 mOhms: -----Acceptable
 - d. +15.1 to +50.0 mOhms: -----Marginal
 - e. +50.1 to +1000 mOhms: -----Unstable
 - f. >+1000 mOhms:-----Open Failure

CABLE RETENTION:

- 1) Apply 15 pounds (6.8 kg) for cable retention test.
- 2) Pull to destruct.
- 3) MIL-PRF-30192, paragraph. 4.6.21.

ATTRIBUTE DEFINITIONS Continued

The following is a brief, simplified description of attributes

INSULATION RESISTANCE (IR):

To determine the resistance of insulation materials to leakage of current through or on the surface of these materials when a DC potential is applied.

- 1) PROCEDURE:
 - a. Reference document: MIL-PRF-39012, paragraph. 4.6.8 per MIL-STD-202-302.
 - b. Test Conditions:
 - i. Between Adjacent Contacts or Signal-to-Ground
 - ii. Electrification Time 2.0 minutes
 - iii. Test Voltage (500 VDC) corresponds to calibration settings for measuring resistances.
- 2) MEASUREMENTS:
- 3) When the specified test voltage is applied (VDC), the insulation resistance shall not be less than 1000 megohms.

DIELECTRIC WITHSTANDING VOLTAGE (DWV):

To determine if the sockets can operate at its rated voltage and withstand momentary over potentials due to switching, surges, and other similar phenomenon. Separate samples are used to evaluate the effect of environmental stresses so not to influence the readings from arcing that occurs during the measurement process.

- 1) PROCEDURE:
 - a. Reference document: MIL-PRF-39012, paragraph. 4.6.14 per MIL-STD-202-301.
 - b. Test Conditions:
 - i. Between Adjacent Contacts or Signal-to-Ground
 - ii. Barometric Test Condition 1(Sea Level) Test voltage applied for 60 seconds.
 - iii. Rate of Application 500 V/Sec
 - iv. Test Voltage (VAC) until breakdown occurs
- 2) MEASUREMENTS/CALCULATIONS
 - a. The breakdown voltage shall be measured and recorded.
 - b. The dielectric withstanding voltage shall be recorded as 75% of the minimum breakdown voltage.
 - c. The working voltage shall be recorded as one-third (1/3) of the dielectric withstanding voltage (one-fourth of the breakdown voltage).

RESULTS

Cable Pull force

- 0° Pull
 - Group 1 LL043-24BJ-505050-0152
 - Min -----44.39 lbs
 - Max -----48.15 lbs

Insulation Resistance minimums, IR

Pin to Ground

- Initial
 - Mated -----45000 Meg Ω ----- Passed
- Thermal Shock
 - Mated -----45000 Meg Ω ----- Passed

Dielectric Withstanding Voltage minimums, DWV

- Minimums
 - Test Voltage -----500 VAC

Pin to Ground

- Initial DWV -----Passed
- Thermal DWV -----Passed

RESULTS Continued

Length & Mass

IR/DWV Group

Length

- 24BJ**
- **Min -----1005.00 mm**
- **Max -----1006.00 mm**

Mass

- 24BJ**
- **Min -----38.27 g**
- **Max -----38.35 g**

Cable Pull Group

Length

- 24BJ**
- **Min ----- 154.00 mm**
- **Max ----- 155.00 mm**

Mass

- 24BJ**
- **Min -----10.69 g**
- **Max -----10.74 g**

RESULTS Continued

Interface Gaging

IR/DWV Group

24BJ

Initial

- **Min ----- 0.0005 in**
- **Max ----- 0.0005 in**

After Thermal Shock

- **Min ----- 0.0010 in**
- **Max ----- 0.0020 in**

Cable Pull Group

24BJ

Initial

- **Min ----- 0.0010 in**
- **Max ----- 0.0020 in**

After Retention

- **Min ----- 0.0005 in**
- **Max ----- 0.0015 in**

RESULTS Continued

LLCR IR/DWV (4 ground and 4 signal LLCR test points)

Ground pin

- **Initial** ----- 32.71 mOhms Max
- **Thermal Shock**
 - <= +5.0 mOhms-----4 Points ----- Stable
 - +5.1 to +10.0 mOhms -----0 Points ----- Minor
 - +10.1 to +15.0 mOhms -----0 Points ----- Acceptable
 - +15.1 to +50.0 mOhms -----0 Points ----- Marginal
 - +50.1 to +1000 mOhms-----0 Points ----- Unstable
 - >+1000 mOhms-----0 Points ----- Open Failure

Signal pin

- **Initial** ----- 37.25 mOhms Max
- **Thermal Shock**
 - <= +5.0 mOhms-----4 Points ----- Stable
 - +5.1 to +10.0 mOhms -----0 Points ----- Minor
 - +10.1 to +15.0 mOhms -----0 Points ----- Acceptable
 - +15.1 to +50.0 mOhms -----0 Points ----- Marginal
 - +50.1 to +1000 mOhms-----0 Points ----- Unstable
 - >+1000 mOhms-----0 Points ----- Open Failure

LLCR Cable Pull (4 ground and 4 signal LLCR test points)

Ground pin

- **Initial** ----- 10.13 mOhms Max
- **After 15lb Retention**
 - <= +5.0 mOhms-----4 Points ----- Stable
 - +5.1 to +10.0 mOhms -----0 Points ----- Minor
 - +10.1 to +15.0 mOhms -----0 Points ----- Acceptable
 - +15.1 to +50.0 mOhms -----0 Points ----- Marginal
 - +50.1 to +1000 mOhms-----0 Points ----- Unstable
 - >+1000 mOhms-----0 Points ----- Open Failure

Signal pin

- **Initial** ----- 9.93 mOhms Max
- **After 15lb Retention**
 - <= +5.0 mOhms-----4 Points ----- Stable
 - +5.1 to +10.0 mOhms -----0 Points ----- Minor
 - +10.1 to +15.0 mOhms -----0 Points ----- Acceptable
 - +15.1 to +50.0 mOhms -----0 Points ----- Marginal
 - +50.1 to +1000 mOhms-----0 Points ----- Unstable
 - >+1000 mOhms-----0 Points ----- Open Failure

DATA SUMMARIES

INSULATION RESISTANCE (IR):

Pin to Ground	
Mated	
Minimum	24BJ
Initial	45000
Thermal Shock	45000

DIELECTRIC WITHSTANDING VOLTAGE (DWV):

Voltage Rating Summary	
Minimum	24BJ
Test Voltage	500

Pin to Ground	
Initial Test Voltage	Pass
After Thermal Shock Test Voltage	Pass

Cable Pull Force:

0° Pull

Group 1 LL043-24BJ-505050-0152

	Force (lbs)
Minimum	44.39
Maximum	48.15
Average	46.10

DATA SUMMARIES Continued

LENGTH & MASS

IR/DWV Group

24BJ	Length (mm)	Mass (g)
1	1005.00	38.27
2	1006.00	38.28
3	1006.00	38.28
4	1005.00	38.35

Cable Pull Group

Group 2		
24BJ	Length (mm)	Mass (g)
1	155.00	10.74
2	155.00	10.73
3	154.00	10.69
4	155.00	10.70

DATA SUMMARIES Continued

INTERFACE GAGING

IR/DWV Group

Gaging (0.000 /0.003) (inch)			
24BJ	Initial	Post Ther Shock	Delta
1	0.0005	0.0010	0.0005
2	0.0005	0.0020	0.0015
3	0.0005	0.0010	0.0005
4	0.0005	0.0010	0.0005

Cable Pull Group

Gaging (0.000 /0.003) (inch)			
24BJ	Initial	Retention	Delta
1	0.0015	0.0005	0.0010
2	0.0010	0.0005	0.0005
3	0.0010	0.0015	0.0005
4	0.0020	0.0015	0.0005

DATA SUMMARIES Continued

LLCR IR/DWV:

- 1) A total of 4 signal and 4 ground points were measured.
- 2) EIA-364-23, *Low Level Contact Resistance Test Procedure for Electrical Connectors and Sockets*.
- 3) A computer program, *LLCR 221.exe*, ensures repeatability for data acquisition.
- 4) The following guidelines are used to categorize the changes in LLCR as a result from stressing.
 - a. $\leq +5.0$ mOhms: -----Stable
 - b. $+5.1$ to $+10.0$ mOhms:-----Minor
 - c. $+10.1$ to $+15.0$ mOhms: -----Acceptable
 - d. $+15.1$ to $+50.0$ mOhms: -----Marginal
 - e. $+50.1$ to $+1000$ mOhms: -----Unstable
 - f. $>+1000$ mOhms:-----Open Failure

LLCR Measurement Summaries by Pin Type				
Date	11/11/2024	11/19/2024		
Room Temp (Deg C)	22	22		
Rel Humidity (%)	50	55		
Technician	Kason He	Kason He		
mOhm values	Actual	Delta		
	Initial	Thermal Shock		
Pin Type: Signal 1				
Average	37.185	0.3675		
St. Dev.	0.0520	0.1531		
Min	37.13	0.18		
Max	37.25	0.52		
Summary Count	4	4		
Total Count	4	4		
Pin Type: GND 1				
Average	32.1875	0.31		
St. Dev.	0.3856	0.2724		
Min	31.85	0.06		
Max	32.71	0.57		
Summary Count	4	4		
Total Count	4	4		

LLCR Delta Count by Category						
	Stable	Minor	Acceptable	Marginal	Unstable	Open
mOhms	≤ 5	$>5 \ \& \ \leq 10$	$>10 \ \& \ \leq 15$	$>15 \ \& \ \leq 50$	$>50 \ \& \ \leq 1000$	>1000
After Thermal Shock	8	0	0	0	0	0

DATA SUMMARIES Continued

LLCR Cable Pull:

- 1) A total of 4 signal and 4 ground points were measured.
- 2) EIA-364-23, *Low Level Contact Resistance Test Procedure for Electrical Connectors and Sockets*.
- 3) A computer program, *LLCR 221.exe*, ensures repeatability for data acquisition.
- 4) The following guidelines are used to categorize the changes in LLCR as a result from stressing.
 - a. $\leq +5.0$ mOhms: -----Stable
 - b. $+5.1$ to $+10.0$ mOhms: -----Minor
 - c. $+10.1$ to $+15.0$ mOhms: -----Acceptable
 - d. $+15.1$ to $+50.0$ mOhms: -----Marginal
 - e. $+50.1$ to $+1000$ mOhms: -----Unstable
 - f. $>+1000$ mOhms: -----Open Failure

LLCR Measurement Summaries by Pin Type				
Date	11/11/2024	11/11/2024		
Room Temp (Deg C)	23	23		
Rel Humidity (%)	50	50		
Technician	Kason He	Kason He		
mOhm values	Actual	Delta		
	Initial	15lb Retention		
Pin Type: Signal 1				
Average	9.59	0.46		
St. Dev.	0.23	0.08		
Min	9.42	0.37		
Max	9.93	0.53		
Summary Count	4	4		
Total Count	4	4		
Pin Type: GND 1				
Average	6.37	0.06		
St. Dev.	2.51	0.03		
Min	5.04	0.02		
Max	10.13	0.08		
Summary Count	4	4		
Total Count	4	4		

LLCR Delta Count by Category						
	Stable	Minor	Acceptable	Marginal	Unstable	Open
mOhms	≤ 5	$>5 \ \& \ \leq 10$	$>10 \ \& \ \leq 15$	$>15 \ \& \ \leq 50$	$>50 \ \& \ \leq 1000$	>1000
After 15lb Retention	8	0	0	0	0	0

EQUIPMENT AND CALIBRATION SCHEDULES

Equipment #: HZ-TCT-01

Description: Normal force analyzer

Manufacturer: Mecmesin Multitester

Model: Mecmesin Multitester 2.5-i

Serial #: 08-1049-04

Accuracy: Last Cal: 3/5/2024, Next Cal: 3/4/2025

Equipment #: HZ-TSC-01

Description: Vertical Thermal Shock Chamber

Manufacturer: Cincinnatti Sub Zero

Model: VTS-3-6-6-SC/AC

Serial #: 10-VT14994

Accuracy: See Manual

... Last Cal: 04/16/2024, Next Cal: 04/15/2025

Equipment #: DG-HPT-01

Description: Hipot Safety Tester

Manufacturer: Vitrek

Model: V73

Serial #: 025866

Accuracy:

... Last Cal: 04/16/2024, Next Cal: 04/15/2025

Equipment #: HZ-MO-05

Description: Micro-ohmmeter

Manufacturer: Keithley

Model: 3706

Serial #: 1285188

Accuracy: Last Cal: 1/2/2024, Next Cal: 1/1/2025