

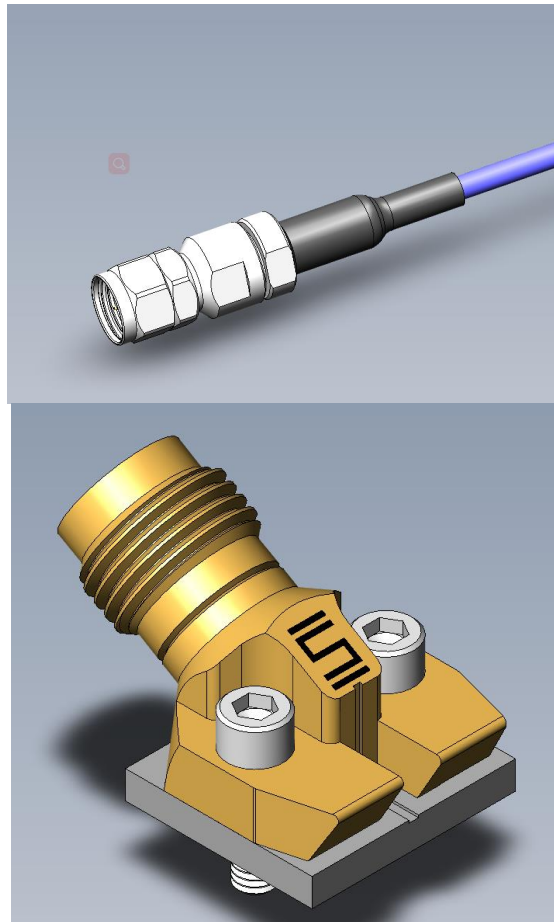

Project Number: Design Qualification Test Report	Tracking Code: CR-1317901_Report_Rev_1
Requested by: Brian Luallen	Date: 11/7/2025
Part #: 185-J-P-EG-ST-AL-01/ RF086-18SP-505050-0304	Tech: Brian Stemle
Part description: 185-J-P / RF086	Qty to test: 20
Test Start: 08/25/2025	Test Completed: 11/6/2025



## DESIGN QUALIFICATION TEST REPORT

185-J-P / RF086  
185-J-P-EG-ST-AL-01/ RF086-18SP-505050-0304

Tracking Code: CR-1317901_Report_Rev_1	Part #: 185-J-P-EG-ST-AL-01/ RF086-18SP-505050-0304
Part description: 185-J-P / RF086	

**REVISION HISTORY**

<b>DATA</b>	<b>REV.NUM.</b>	<b>DESCRIPTION</b>	<b>ENG</b>
11/7/2025	1	Initial Issue	PC

## CERTIFICATION

All instruments and measuring equipment were calibrated to National Institute for Standards and Technology (NIST) traceable standards according to ISO 10012-1 and ANSI/NCSL 2540-1, as applicable.

All contents contained herein are the property of Samtec. No portion of this report, in part or in full shall be reproduced without prior written approval of Samtec.

### SCOPE

To perform the following tests: Design Qualification test. Please see test plan.

### APPLICABLE DOCUMENTS

Standards: EIA Publication 364, MIL-PRF-39012.

### TEST SAMPLES AND PREPARATION

- 1) All materials were manufactured in accordance with the applicable product specification.
- 2) All test samples were identified and encoded to maintain traceability throughout the test sequences.
- 3) After soldering, the parts to be used for LLCR and IR\_DWV testing were cleaned according to TLWI-0001.
- 4) Either an automated cleaning procedure or an ultrasonic cleaning procedure may be used.
- 5) The automated procedure is used with aqueous compatible soldering materials.
- 6) Parts not intended for testing LLCR and IR\_DWV are visually inspected and cleaned if necessary.
- 7) Any additional preparation will be noted in the individual test sequences.
- 8) Solder Information: Lead Free

**FLOWCHARTS****Mating/Unmating/Durability**Group 1

185-J-P-EG-ST-AL-01

RF086-18SP-505050-0304

2 Assemblies

**Step Description**

1. LLCR <sup>(1)</sup>  
*Note: INITIAL*
2. Cycles  
Quantity = 500 Cycles
3. LLCR <sup>(1)</sup>  
*Note: Max Delta = 15mOhm*

-----  
(1) LLCR = EIA-364-23Open Circuit Voltage = 20 mV Max  
Test Current = 100 mA Max**Mechanical Shock/Random Vibration/Event Detection**Group 1

185-J-P-EG-ST-AL-01

RF086-18SP-505050-0304

10 Assemblies

**Step Description**

1. Nanosecond Event Detection  
(Mechanical Shock) <sup>(1)</sup>
2. Nanosecond Event Detection  
(Random Vibration) <sup>(2)</sup>

-----  
(1) Nanosecond Event Detection (Mechanical Shock)Use EIA-364-87 for Nanosecond Event Detection:  
Test Condition = F (50 nanoseconds at 10 ohms)Use EIA-364-27 for Mechanical Shock:  
Test Condition = C (100 G Peak, 6 milliseconds, Half Sine)  
Number of Shocks = 3 Per Direction, Per Axis, 18 Total

(2) Nanosecond Event Detection (Random Vibration)

Use EIA-364-87 for Nanosecond Event Detection:  
Test Condition = F (50 nanoseconds at 10 ohms)Use EIA-364-28 for Random Vibration:  
Condition = VB (7.56 gRMS Average, 2 Hours/Axis)

**FLOWCHARTS Continued****IR/DWV****Pin-to-Ground**Group 1

185-J-P-EG-ST-AL-01

RF086-18SP-505050-0304

10 Assemblies

Step	Description
1.	Interface Gaging <i>Note: Measure and record center contact recess from interface reference plane</i>
2.	IR (2) - Non Standard
3.	DWV at Test Voltage (1) - Non Standard Test Voltage = 500 VAC
4.	LLCR (3) - Non Standard <i>Note: Signal and ground.</i>
5.	Thermal Shock (4) - Non Standard
6.	IR (2) - Non Standard
7.	DWV at Test Voltage (1) - Non Standard Test Voltage = 500 VAC
8.	LLCR (3) - Non Standard Max Delta = 15 mOhm <i>Note: Signal and ground.</i>
9.	Interface Gaging <i>Note: Measure and record center contact recess from interface reference plane</i>

**(1) DWV at Test Voltage = Other**

Test Condition = 1 (Sea Level) Test voltage applied for 60 seconds  
MIL-PRF-39012, Paragraph. 4.6.14 per MIL-STD-202-301

**(2) IR = Other**

Test Condition = 500V DC, 2 Minutes Max  
MIL-PRF-39012, Paragraph 4.6.8 per MIL-STD-202-302

**(3) LLCR = Other**

Open Circuit Voltage = 20 mV Max  
Test Current = 100 mA Max  
MIL-PRF-39012, Paragraph 4.6.13 except current to be 100mA nominal and voltage to be 20 mV maximum.

**(4) Thermal Shock = Other**

Exposure Time at Temperature Extremes = 1/2 Hour  
Test Condition = I (-65°C to +125°C)  
Test Duration = test condition B except 10 cycles instead of 5.  
MIL-PRF-39012, Paragraph. 4.6.17 per MIL-STD-202-107

**FLOWCHARTS Continued****Center Contact Retention****Minimum Force**Group 1

185-J-P-EG-ST-AL-01

5 Assemblies

Minimum Force

*Note: Test I.A.W. MIL-PRF-39012 par.  
4.6.9.*

**Step Description**

1. Measure Contact Recess @  
Interface
2. Apply Minimum Force Onto  
Socket Face  
*Note: Applied Force = 4 lbf (17.8 N)*
3. Apply Min Force Onto Contact  
In Opposite Direction  
*Note: Applied Force = 4 lbf (17.8 N)*
4. Measure Contact Recess @  
Interface

**Center Contact Captivation**Group 1

185-J-P-EG-ST-AL-01

5 Assemblies

Maximum Force.

*Note: This is a destructive test.  
Apply force to the center socket contact  
(push on contact from pin end of  
assembly) and record maximum force at  
captivation failure and note cause of  
failure. Examples of failure; Contact  
disengaged from internal dielectric  
capture bead. Interface bushing  
disengaged.*

**Step Description**

1. Apply Force On The Socket  
Center Contact  
*Note: Crosshead speed range 0.5-  
5.0 mm/min will be sufficient.  
Maximum force is the load force  
measured at captivation failure.*

## ATTRIBUTE DEFINITIONS

The following is a brief, simplified description of attributes.

### THERMAL SHOCK:

- 1) MIL-PRF-39012, *Paragraph. 4.6.17 per MIL-STD-202-107*
- 2) Test Condition: I (-65°C to +125°C)
- 3) Test Time: ½ hour dwell at each temperature extreme
- 4) Test Duration: Test condition B except 10 cycles instead of 5.
- 5) All test samples are pre-conditioned at ambient.
- 6) All test samples are exposed to environmental stressing in the mated condition.

### MATING/UNMATING:

- 1) Reference document: EIA-364-13, *Mating and Unmating Forces Test Procedure for Electrical Connectors.*
- 2) The full insertion position was to within 0.003” to 0.004” of the plug bottoming out in the receptacle to prevent damage to the system under test.
- 3) One of the mating parts is secured to a floating X-Y table to prevent damage during cycling.

### LLCR:

- 1) EIA-364-23, *Low Level Contact Resistance Test Procedure for Electrical Connectors and Sockets.*
- 2) A computer program, *LLCR 221.exe*, ensures repeatability for data acquisition.
- 3) The following guidelines are used to categorize the changes in LLCR as a result from stressing
  - a.  $\leq +5.0$  mOhms: ----- Stable
  - b.  $+5.1$  to  $+10.0$  mOhms:----- Minor
  - c.  $+10.1$  to  $+15.0$  mOhms: ----- Acceptable
  - d.  $+15.1$  to  $+50.0$  mOhms: ----- Marginal
  - e.  $+50.1$  to  $+1000$  mOhms: ----- Unstable
  - f.  $>+1000$  mOhms:----- Open Failure

### MECHANICAL SHOCK (Specified Pulse):

- 1) Reference document: EIA-364-27, *Mechanical Shock Test Procedure for Electrical Connectors*
- 2) Test Condition G
- 3) Peak Value: 100 G
- 4) Duration: 6 Milliseconds
- 5) Wave Form: Sawtooth
- 6) Velocity: 12.3 ft/s
- 7) Number of Shocks: 3 Shocks / Direction, 3 Axis (18 Total)

### VIBRATION:

- 1) Reference document: EIA-364-28, *Vibration Test Procedure for Electrical Connectors*
- 2) Test Condition V, Letter B
- 3) Power Spectral Density:  $0.10 \text{ G}^2 / \text{Hz}$
- 4) G ‘RMS’: 7.56
- 5) Frequency: 50 to 2000 Hz
- 6) Duration: 2.0 Hours per axis (3 axis total)

### NANOSECOND-EVENT DETECTION:

- 1) Reference document: EIA-364-87, *Nanosecond-Event Detection for Electrical Connectors*
- 2) Prior to test, the samples were characterized to assure the low nanosecond event being monitored will trigger the detector.
- 3) After characterization it was determined the test samples could be monitored for 50 nanosecond events

**ATTRIBUTE DEFINITIONS Continued**

The following is a brief, simplified description of attributes

**INSULATION RESISTANCE (IR):**

To determine the resistance of insulation materials to leakage of current through or on the surface of these materials when a DC potential is applied.

- 1) PROCEDURE:
  - a. Reference document: EIA-364-21, *Insulation Resistance Test Procedure for Electrical Connectors*.
  - b. Test Conditions:
    - i. Between Adjacent Contacts or Signal-to-Ground
    - ii. Electrification Time 2.0 minutes
    - iii. Test Voltage (500 VDC) corresponds to calibration settings for measuring resistances.
- 2) MEASUREMENTS:
- 3) When the specified test voltage is applied (VDC), the insulation resistance shall not be less than 5000 megohms.

**DIELECTRIC WITHSTANDING VOLTAGE (DWV):**

To determine if the sockets can operate at its rated voltage and withstand momentary over potentials due to switching, surges, and other similar phenomenon. Separate samples are used to evaluate the effect of environmental stresses so not to influence the readings from arcing that occurs during the measurement process.

- 1) PROCEDURE:
  - a. Reference document: EIA-364-20, *Withstanding Voltage Test Procedure for Electrical Connectors*.
  - b. Test Conditions:
    - i. Between Adjacent Contacts or Signal-to-Ground
    - ii. Barometric Test Condition 1
    - iii. Rate of Application 500 V/Sec
    - iv. Test Voltage (VAC) until breakdown occurs
- 2) MEASUREMENTS/CALCULATIONS
  - a. The breakdown voltage shall be measured and recorded.
  - b. The dielectric withstanding voltage shall be recorded as 75% of the minimum breakdown voltage.
  - c. The working voltage shall be recorded as one-third (1/3) of the dielectric withstanding voltage (one-fourth of the breakdown voltage).

## RESULTS

### Center Contact Captivation

- Min ----- 6.05 lbs
- Max ----- 6.50 lbs

### Insulation Resistance minimums, IR

#### Pin to Ground

- Initial
  - Mated ----- 45000 Meg  $\Omega$  ----- Passed
- Thermal Shock
  - Mated ----- 45000 Meg  $\Omega$  ----- Passed

### Dielectric Withstanding Voltage minimums, DWV

- Minimums
  - Test Voltage ----- 500 VAC

#### Pin to Ground

- Initial DWV ----- Passed
- Thermal DWV ----- Passed

### Interface Gaging

#### IR/DWV Group

##### Initial

- Min ----- 0.0002 Inch
- Max ----- 0.0010 Inch

##### After Thermal shock

- Min ----- 0.0001 Inch
- Max ----- 0.0010 Inch

#### Center Contact Retention Group

##### Initial

- Min ----- 0.0009 Inch
- Max ----- 0.0018 Inch

##### After Retention force

- Min ----- 0.0015 Inch
- Max ----- 0.0019 Inch

**RESULTS Continued**

**LLCR IR/DWV (2 signal and 2 ground LLCR test points)**

**Signal Pin**

- **Initial** ----- 43.9 mOhms Max

**Ground Pin**

- **Initial** ----- 11.19 mOhms Max
- **Thermal Shock**
  - **<= +5.0 mOhms**-----4 Points ----- Stable
  - **+5.1 to +10.0 mOhms** -----0 Points ----- Minor
  - **+10.1 to +15.0 mOhms** -----0 Points ----- Acceptable
  - **+15.1 to +50.0 mOhms** -----0 Points ----- Marginal
  - **+50.1 to +1000 mOhms**-----0 Points ----- Unstable
  - **>+1000 mOhms**-----0 Points ----- Open Failure

**LLCR Durability (10 signal and 10 ground LLCR test points)**

**Signal Pin**

- **Initial** ----- 41.52 mOhms Max

**Ground Pin**

- **Initial** -----8.37 mOhms Max
- **Durability, 500 Cycles**
  - **<= +5.0 mOhms**----- 18 Points ----- Stable
  - **+5.1 to +10.0 mOhms** -----1 Points ----- Minor
  - **+10.1 to +15.0 mOhms** -----1 Points ----- Acceptable
  - **+15.1 to +50.0 mOhms** -----0 Points ----- Marginal
  - **+50.1 to +1000 mOhms**-----0 Points ----- Unstable
  - **>+1000 mOhms** -----0 Points ----- Open Failure

**Mechanical Shock & Random Vibration:**

- **Shock**
  - **No Damage**----- Pass
  - **50 Nanoseconds** ----- Pass
- **Vibration**
  - **No Damage**----- Pass
  - **50 Nanoseconds** ----- Pass

**DATA SUMMARIES**

**Center Contact Captivation**

	<b>Push Force</b>	
	Newtons	Force (Lbs)
Minimum	26.91	6.05
Maximum	28.91	6.50
Average	27.98	6.29

**INSULATION RESISTANCE (IR):**

	<b>Pin to Ground</b>		
	Mated	Unmated	Unmated
Minimum	<b>185-J-P / RF086</b>	<b>185-J-P</b>	<b>RF086</b>
<b>Initial</b>	45000	45000	45000
<b>Thermal</b>	45000	45000	45000

**DIELECTRIC WITHSTANDING VOLTAGE (DWV):**

<b>Voltage Rating Summary</b>	
Minimum	<b>185-J-P / RF086</b>
<b>Test Voltage</b>	500

<b>Pin to Ground</b>	
<b>Initial Test Voltage</b>	Passed
<b>After Thermal Test Voltage</b>	Passed
<b>After Humidity Test Voltage</b>	Passed

**DATA SUMMARIES Continued****INTERFACE GAGING****IR/DWV Group**

<b>Contact Recess Interface (Group 1)(.0030/.0000)</b>			
<b>Sample</b>	<b>Initial</b>	<b>After Thermal Shock</b>	<b>Delta</b>
3	0.00100	0.00085	0.00015
4	0.00050	0.00030	0.00020
5	0.00055	0.00045	0.00010
6	0.00050	0.00040	0.00010
7	0.00020	0.00010	0.00010
8	0.00060	0.00045	0.00015
9	0.00100	0.00100	0.00000
10	0.00050	0.00060	0.00010
11	0.00090	0.00075	0.00015
12	0.00080	0.00085	0.00005
Min	0.00020	0.00010	0.00000
Max	0.00100	0.00100	0.00020
Average	0.00066	0.00058	0.00011

**Center Contact Retention**

<b>Contact Recess Interface (Group 1)(.0030/.0000)</b>			
<b>Sample</b>	<b>Initial</b>	<b>After 4lb Retention</b>	<b>Delta</b>
23	0.0011	0.00150	0.0004
24	0.0009	0.00170	0.0008
25	0.0017	0.00180	0.0001
26	0.0018	0.00190	0.0001
27	0.0010	0.00150	0.0005
Min	0.0009	0.0015	0.0001
Max	0.0018	0.0019	0.0008
Average	0.0013	0.0017	0.0004

### DATA SUMMARIES Continued

**LLCR Durability:**

- 1) A total of 2 signal and 2 ground points were measured.
- 2) EIA-364-23, *Low Level Contact Resistance Test Procedure for Electrical Connectors and Sockets*.
- 3) A computer program, *LLCR 221.exe*, ensures repeatability for data acquisition.
- 4) The following guidelines are used to categorize the changes in LLCR as a result from stressing.
  - a.  $\leq +5.0$  mOhms: ----- Stable
  - b.  $+5.1$  to  $+10.0$  mOhms: ----- Minor
  - c.  $+10.1$  to  $+15.0$  mOhms: ----- Acceptable
  - d.  $+15.1$  to  $+50.0$  mOhms: ----- Marginal
  - e.  $+50.1$  to  $+1000$  mOhms ----- Unstable
  - f.  $>+1000$  mOhms: ----- Open Failure

LLCR Measurement Summaries by Pin Type			
Date	8/27/2025	8/29/2025	
Room Temp (Deg C)	22	23	
Rel Humidity (%)	44	47	
Technician	Brian Stemle	Brian Stemle	
<b>mOhm values</b>	<b>Actual</b>	<b>Delta</b>	
	<b>Initial</b>	<b>500 Cycles</b>	
Pin Type: Signal 1			
Average	41.36	1.57	
St. Dev.	3.59	1.7	
Min	38.82	0.37	
Max	43.9	2.78	
Summary Count	2	2	
Total Count	2	2	
Pin Type: GND 1			
Average	10.54	1.91	
St. Dev.	0.92	1.56	
Min	9.89	0.81	
Max	11.19	3.01	
Summary Count	2	2	
Total Count	2	2	

LLCR Delta Count by Category						
	Stable	Minor	Acceptable	Marginal	Unstable	Open
<b>mOhms</b>	$\leq 5$	$>5 \ \& \ \leq 10$	$>10 \ \& \ \leq 15$	$>15 \ \& \ \leq 50$	$>50 \ \& \ \leq 1000$	$>1000$
<b>500 Cycles</b>	4	0	0	0	0	0

### DATA SUMMARIES Continued

**LLCR IR/DWV:**

- 1) A total of 10 signal and 10 ground points were measured.
- 2) EIA-364-23, *Low Level Contact Resistance Test Procedure for Electrical Connectors and Sockets*.
- 3) A computer program, *LLCR 221.exe*, ensures repeatability for data acquisition.
- 4) The following guidelines are used to categorize the changes in LLCR as a result from stressing.
  - a.  $\leq +5.0$  mOhms: ----- Stable
  - b.  $+5.1$  to  $+10.0$  mOhms:----- Minor
  - c.  $+10.1$  to  $+15.0$  mOhms: ----- Acceptable
  - d.  $+15.1$  to  $+50.0$  mOhms: ----- Marginal
  - e.  $+50.1$  to  $+1000$  mOhms: ----- Unstable
  - f.  $>+1000$  mOhms:----- Open Failure

LLCR Measurement Summaries by Pin Type			
Date	11/6/2025	11/6/2025	
Room Temp (Deg C)	22	22	
Rel Humidity (%)	39	40	
Technician	Brian Stemle	Brian Stemle	
<b>mOhm values</b>	<b>Actual</b>	<b>Delta</b>	
	<b>Initial Initial</b>	<b>IR DWV</b>	
<b>Pin Type: Signal 1</b>			
Average	38.89	2.76	
St. Dev.	1.31	4.21	
Min	37.18	0.35	
Max	41.52	12.32	
Summary Count	10	10	
Total Count	10	10	
<b>Pin Type: GND 1</b>			
Average	7.97	1.23	
St. Dev.	0.27	0.58	
Min	7.63	0.35	
Max	8.37	2.12	
Summary Count	10	10	
Total Count	10	10	

LLCR Delta Count by Category						
	Stable	Minor	Acceptable	Marginal	Unstable	Open
<b>mOhms</b>	$\leq 5$	$>5 \ \& \ \leq 10$	$>10 \ \& \ \leq 15$	$>15 \ \& \ \leq 50$	$>50 \ \& \ \leq 1000$	$>1000$
<b>500 Cycles</b>	<b>18</b>	<b>1</b>	<b>1</b>	<b>0</b>	<b>0</b>	<b>0</b>

Tracking Code: CR-1317901_Report_Rev_1	Part #: 185-J-P-EG-ST-AL-01/ RF086-18SP-505050-0304
Part description: 185-J-P / RF086	

**DATA SUMMARIES Continued**

**Nanosecond Event Detection:**

<b>Shock and Vibration Event Detection Summary</b>	
Contacts tested	60
Test Condition	C, 100g's, 6ms, Half-Sine
Shock Events	0
Test Condition	V-B, 7.56 rms g
Vibration Events	0
<b>Total Events</b>	<b>0</b>

Tracking Code: CR-1317901_Report_Rev_1	Part #: 185-J-P-EG-ST-AL-01/ RF086-18SP-505050-0304
Part description: 185-J-P / RF086	

**EQUIPMENT AND CALIBRATION SCHEDULES**

**Equipment #:** TCT-04  
**Description:** Dillon Quantrol TC21 25-1000 mm/min series test stand  
**Manufacturer:** Dillon Quantrol  
**Model:** TC2 I series test stand  
**Serial #:** 04-1041-04  
**Accuracy:** Speed Accuracy: +/- 5% of indicated speed; Speed Accuracy: +/- 5% of indicated speed;  
... Last Cal: 05/29/2025, Next Cal: 05/29/2026

**Equipment #:** MO-11  
**Description:** Switch/Multimeter  
**Manufacturer:** Keithley  
**Model:** 3706  
**Serial #:** 120169  
**Accuracy:** See Manual  
... Last Cal: 09/11/2025, Next Cal: 09/11/2026

**Equipment #:** TSC-01  
**Description:** Vertical Thermal Shock Chamber  
**Manufacturer:** Cincinnati Sub Zero  
**Model:** VTS-3-6-6-SC/AC  
**Serial #:** 10-VT14993  
**Accuracy:** See Manual  
... Last Cal: 06/30/2025, Next Cal: 06/30/2026

**Equipment #:** HPT-01  
**Description:** Hipot Safety Tester  
**Manufacturer:** Vitrek  
**Model:** V73  
**Serial #:** 019808  
**Accuracy:**  
... Last Cal: 05/15/2025, Next Cal: 05/15/2026

**Equipment #:** SVC-01  
**Description:** Shock & Vibration Table  
**Manufacturer:** Data Physics  
**Model:** LE-DSA-10-20K  
**Serial #:** 10037  
**Accuracy:** See Manual  
... Last Cal: 11/31/2024, Next Cal: 11/31/2025

Tracking Code: CR-1317901_Report_Rev_1	Part #: 185-J-P-EG-ST-AL-01/ RF086-18SP-505050-0304
Part description: 185-J-P / RF086	

**EQUIPMENT AND CALIBRATION SCHEDULES**

Equipment #: ACLM-01  
Description: Accelerometer  
Manufacturer: PCB Piezotronics  
Model: 352C03  
Serial #: 115819  
Accuracy: See Manual  
... Last Cal: 07/09/2025, Next Cal: 07/09/2026

Equipment #: ED-03  
Description: Event Detector  
Manufacturer: Analysis Tech  
Model: 32EHD  
Serial #: 1100604  
Accuracy: See Manual  
... Last Cal: 06/04/2025, Next Cal: 06/04/2026