

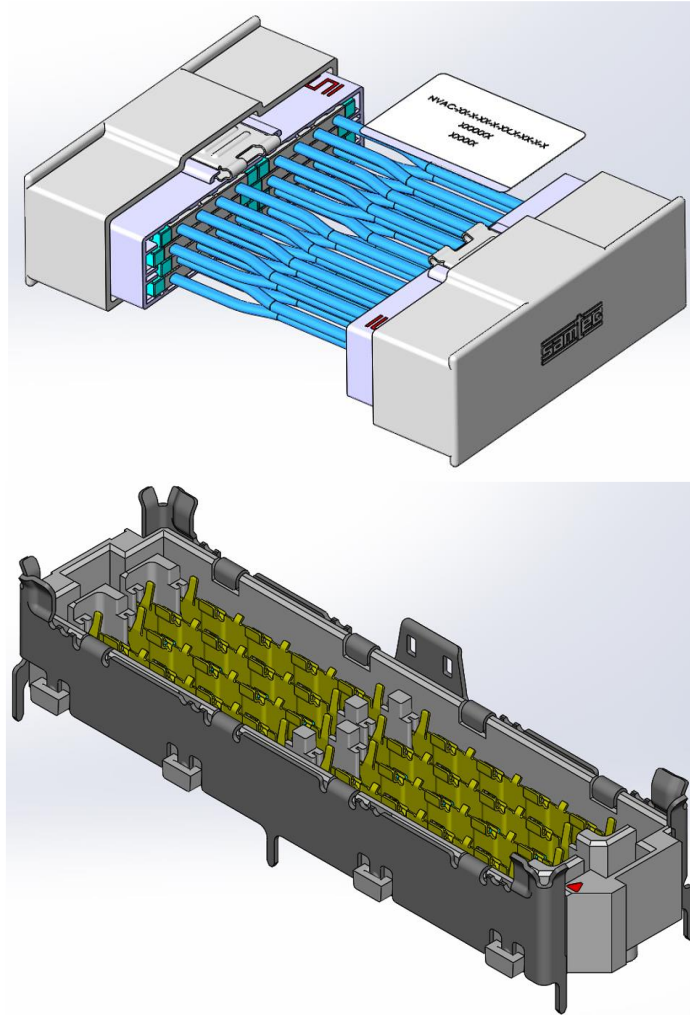

Project Number: Design Qualification Test Report	Tracking Code: CR-698301_Report_Rev_1
Requested by: Zack Weber	Date: 4/8/2022
Part #: NVAC-DP-3-04-2-08.0-01-1-L/NVAM-DP-04-2-02.0-S-2-C	
Part description: NVAC/NVAM	Tech: Daniel Haydon
Test Start: 3/3/2022	Test Completed: 3/17/2022



**DESIGN QUALIFICATION TEST REPORT**  
**NVAC/NVAM**  
**NVAC-DP-3-04-2-08.0-01-1-L/NVAM-DP-04-2-02.0-S-2-C**

Tracking Code: CR-698301_Report_Rev_1	Part #: NVAC-DP-3-04-2-08.0-01-1-L/NVAM-DP-04-2-02.0-S-2-C
Part description: NVAC/NVAM	

**REVISION HISTORY**

<b>DATA</b>	<b>REV.NUM.</b>	<b>DESCRIPTION</b>	<b>ENG</b>
4/8/2022	1	Initial Issue	KH

## CERTIFICATION

All instruments and measuring equipment were calibrated to National Institute for Standards and Technology (NIST) traceable standards according to ISO 10012-1 and ANSI/NCSL 2540-1, as applicable.

All contents contained herein are the property of Samtec. No portion of this report, in part or in full shall be reproduced without prior written approval of Samtec.

### SCOPE

To perform the following tests: Design Qualification test. Please see test plan.

### APPLICABLE DOCUMENTS

Standards: EIA Publication 364

### TEST SAMPLES AND PREPARATION

- 1) All materials were manufactured in accordance with the applicable product specification.
- 2) All test samples were identified and encoded to maintain traceability throughout the test sequences.
- 3) After soldering, the parts to be used for testing were cleaned according to CO-SC-WI-3029.
- 4) Either an automated cleaning procedure or an ultrasonic cleaning procedure may be used.
- 5) The automated procedure is used with aqueous compatible soldering materials.
- 6) Any additional preparation will be noted in the individual test sequences.
- 7) Solder Information: Lead Free
- 8) Samtec Test PCBs used: PCB-111975-TST

## FLOWCHARTS

### Cable Pull

<p style="text-align: center;"><u>Group 1</u></p> <p style="text-align: center;">NVAC-DP-3-04-2-08.0-01-1-L NVAM-DP-04-2-02.0-S-2-C</p> <p style="text-align: center;">10 Assemblies 0 Degrees</p> <p style="text-align: center;"><i>Note: End Wafer Pull</i></p> <hr/> <table style="width: 100%; border-collapse: collapse;"> <thead> <tr> <th style="text-align: left;">Step</th> <th style="text-align: left;">Description</th> </tr> </thead> <tbody> <tr> <td style="text-align: left;">1.</td> <td style="text-align: left;">Cable Pull <sup>(1)</sup></td> </tr> </tbody> </table>	Step	Description	1.	Cable Pull <sup>(1)</sup>	<p style="text-align: center;"><u>Group 2</u></p> <p style="text-align: center;">NVAC-DP-3-04-2-08.0-01-1-L NVAM-DP-04-2-02.0-S-2-C</p> <p style="text-align: center;">10 Assemblies 0 Degrees</p> <p style="text-align: center;"><i>Note: Middle Wafer Position Pull</i></p> <hr/> <table style="width: 100%; border-collapse: collapse;"> <thead> <tr> <th style="text-align: left;">Step</th> <th style="text-align: left;">Description</th> </tr> </thead> <tbody> <tr> <td style="text-align: left;">1.</td> <td style="text-align: left;">Cable Pull <sup>(1)</sup></td> </tr> </tbody> </table>	Step	Description	1.	Cable Pull <sup>(1)</sup>	<p style="text-align: center;"><u>Group 3</u></p> <p style="text-align: center;">NVAC-DP-3-04-2-08.0-01-1-L NVAM-DP-04-2-02.0-S-2-C</p> <p style="text-align: center;">10 Assemblies 45 Degrees - Towards Latch</p> <p style="text-align: center;"><i>Note: End Wafer Pull</i></p> <hr/> <table style="width: 100%; border-collapse: collapse;"> <thead> <tr> <th style="text-align: left;">Step</th> <th style="text-align: left;">Description</th> </tr> </thead> <tbody> <tr> <td style="text-align: left;">1.</td> <td style="text-align: left;">Cable Pull <sup>(1)</sup></td> </tr> </tbody> </table>	Step	Description	1.	Cable Pull <sup>(1)</sup>	<p style="text-align: center;"><u>Group 4</u></p> <p style="text-align: center;">NVAC-DP-3-04-2-08.0-01-1-L NVAM-DP-04-2-02.0-S-2-C</p> <p style="text-align: center;">10 Assemblies 45 Degrees - Towards Latch</p> <p style="text-align: center;"><i>Note: Middle Wafer Position Pull</i></p> <hr/> <table style="width: 100%; border-collapse: collapse;"> <thead> <tr> <th style="text-align: left;">Step</th> <th style="text-align: left;">Description</th> </tr> </thead> <tbody> <tr> <td style="text-align: left;">1.</td> <td style="text-align: left;">Cable Pull <sup>(1)</sup></td> </tr> </tbody> </table>	Step	Description	1.	Cable Pull <sup>(1)</sup>
Step	Description																		
1.	Cable Pull <sup>(1)</sup>																		
Step	Description																		
1.	Cable Pull <sup>(1)</sup>																		
Step	Description																		
1.	Cable Pull <sup>(1)</sup>																		
Step	Description																		
1.	Cable Pull <sup>(1)</sup>																		
<p style="text-align: center;"><u>Group 5</u></p> <p style="text-align: center;">NVAC-DP-3-04-2-08.0-01-1-L NVAM-DP-04-2-02.0-S-2-C</p> <p style="text-align: center;">10 Assemblies 45 Degrees - Towards Short Side</p> <p style="text-align: center;"><i>Note: End Wafer Pull</i></p> <hr/> <table style="width: 100%; border-collapse: collapse;"> <thead> <tr> <th style="text-align: left;">Step</th> <th style="text-align: left;">Description</th> </tr> </thead> <tbody> <tr> <td style="text-align: left;">1.</td> <td style="text-align: left;">Cable Pull <sup>(1)</sup></td> </tr> </tbody> </table>	Step	Description	1.	Cable Pull <sup>(1)</sup>	<p style="text-align: center;"><u>Group 6</u></p> <p style="text-align: center;">NVAC-DP-3-04-2-08.0-01-1-L NVAM-DP-04-2-02.0-S-2-C</p> <p style="text-align: center;">10 Assemblies 45 Degrees - Towards Short Side</p> <p style="text-align: center;"><i>Note: Middle Wafer Position Pull</i></p> <hr/> <table style="width: 100%; border-collapse: collapse;"> <thead> <tr> <th style="text-align: left;">Step</th> <th style="text-align: left;">Description</th> </tr> </thead> <tbody> <tr> <td style="text-align: left;">1.</td> <td style="text-align: left;">Cable Pull <sup>(1)</sup></td> </tr> </tbody> </table>	Step	Description	1.	Cable Pull <sup>(1)</sup>										
Step	Description																		
1.	Cable Pull <sup>(1)</sup>																		
Step	Description																		
1.	Cable Pull <sup>(1)</sup>																		

---

(1) Cable Pull = EIA-364-38  
 Measure and Record Force Required to Failure  
 Failure = Discontinuity >1 microsecond at 10 ohms

## ATTRIBUTE DEFINITIONS

The following is a brief, simplified description of attributes.

### CABLE PULL:

- 1) Secure cable near center and pull on connector
  - a. At  $0^\circ$ , in-line with cable
  - b. At  $45^\circ$ , in-line with cable

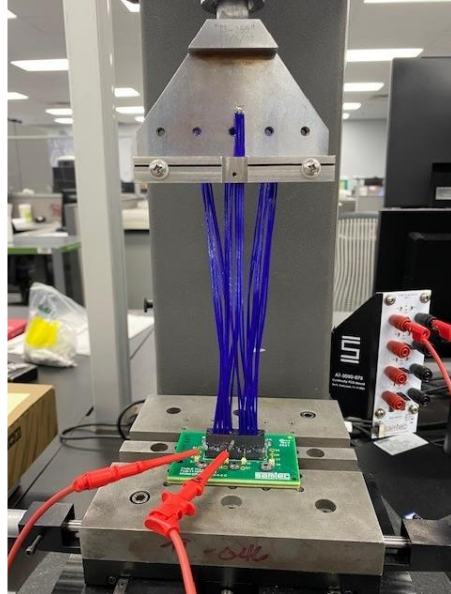

Fig. 1  
 $0^\circ$  Connector pull

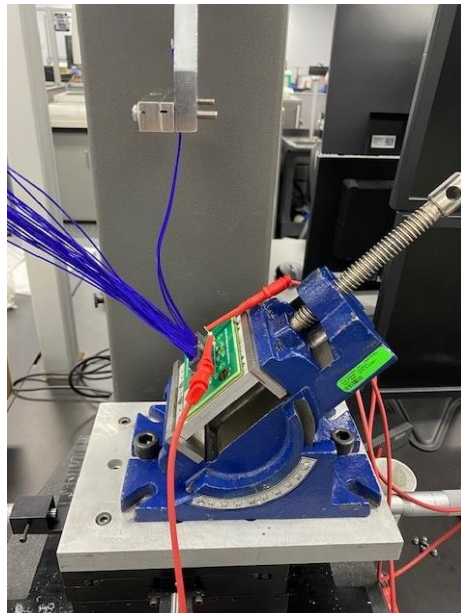

Fig. 2  
 $45^\circ$  Connector pull

**RESULTS**

**Cable Pull force**

**Group 1 End wafer pull**

- **0° Pull**
  - Min ----- 4.635 lbs
  - Max ----- 5.828 lbs

**Group 2 Middle wafer position pull**

- **0° Pull**
  - Min ----- 4.153 lbs
  - Max ----- 5.253 lbs

**Group 3 End wafer pull (Towards Latch)**

- **45° Pull**
  - Min ----- 6.460 lbs
  - Max ----- 8.113 lbs

**Group 4 Middle wafer position pull (Towards Latch)**

- **45° Pull**
  - Min ----- 6.271 lbs
  - Max ----- 8.026 lbs

**Group 5 End wafer pull (Towards Short Side)**

- **45° Pull**
  - Min ----- 4.869 lbs
  - Max ----- 6.035 lbs

**Group 6 Middle wafer position pull (Towards Short Side)**

- **45° Pull**
  - Min ----- 4.492 lbs
  - Max ----- 9.492 lbs

**DATA SUMMARIES****Cable Pull Force:****Group 1 0° Pull End wafer pull**

	Force (lbs)
Minimum	4.635
Maximum	5.828
Average	5.227

**Group 2 0° Pull Middle wafer position pull**

	Force (lbs)
Minimum	4.153
Maximum	5.253
Average	4.739

**Group 3 45° Pull End wafer pull (Towards Latch)**

	Force (lbs)
Minimum	6.460
Maximum	8.113
Average	7.331

**Group 4 45° Pull Middle wafer position pull (Towards Latch)**

	Force (lbs)
Minimum	6.271
Maximum	8.026
Average	6.972

**Group 5 45° Pull End wafer pull (Towards Short Side)**

	Force (lbs)
Minimum	4.869
Maximum	6.035
Average	5.390

**Group 6 45° Pull Middle wafer position pull (Towards Short Side)**

	Force (lbs)
Minimum	4.492
Maximum	9.492
Average	7.208

**EQUIPMENT AND CALIBRATION SCHEDULES****Equipment #:** TCT-04**Description:** Dillon Quantrol TC21 25-1000 mm/min series test stand**Manufacturer:** Dillon Quantrol**Model:** TC2 I series test stand**Serial #:** 04-1041-04**Accuracy:** Speed Accuracy: +/- 5% of indicated speed; Speed Accuracy: +/- 5% of indicated speed;

... Last Cal: 05/29/2021, Next Cal: 05/29/2022