

Project Number: Design Qualification Test Report	Tracking Code: CR-888101_Report_Rev_1
Requested by: Iris Wang	Date: 7/12/2023
Part #: 240-J-P-EP-ST-EL-01/RF086-24SP-505050-0304	
Part description: 240/RF086	Tech: Kason He
Test Start: 3/1/2023	Test Completed: 3/10/2023

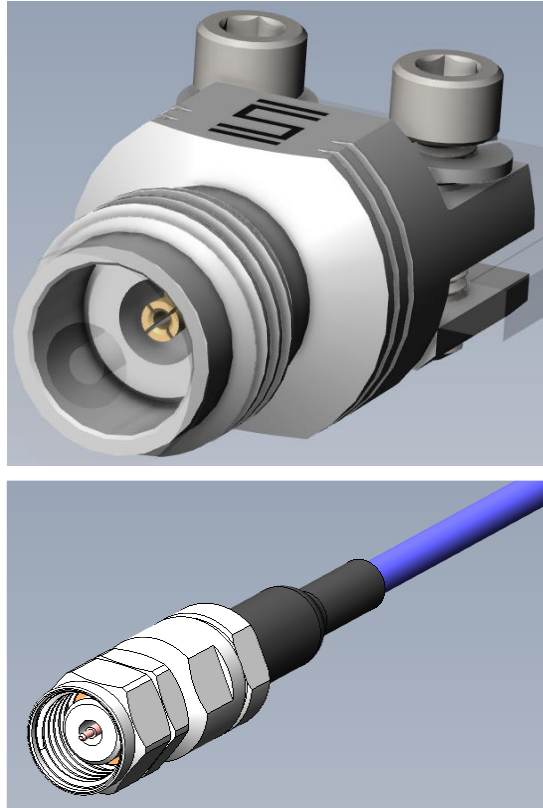

DESIGN QUALIFICATION TEST REPORT
240/RF086
240-J-P-EP-ST-EL-01/RF086-24SP-505050-0304

Tracking Code: CR-888101_Report_Rev_1	Part #: 240-J-P-EP-ST-EL-01/RF086-24SP-505050-0304
Part description: 240/RF086	

REVISION HISTORY

DATA	REV.NUM.	DESCRIPTION	ENG
7/12/2023	1	Initial Issue	KH

CERTIFICATION

All instruments and measuring equipment were calibrated to National Institute for Standards and Technology (NIST) traceable standards according to ISO 10012-1 and ANSI/NCSL 2540-1, as applicable.

All contents contained herein are the property of Samtec. No portion of this report, in part or in full shall be reproduced without prior written approval of Samtec.

SCOPE

To perform the following tests: Design Qualification test. Please see test plan.

APPLICABLE DOCUMENTS

Standards: MIL-PRF-39012, EIA Publication 364.

TEST SAMPLES AND PREPARATION

- 1) All materials were manufactured in accordance with the applicable product specification.
- 2) All test samples were identified and encoded to maintain traceability throughout the test sequences.
- 3) Parts not intended for testing LLCR and DWV/IR are visually inspected and cleaned if necessary.
- 4) Any additional preparation will be noted in the individual test sequences.

FLOWCHARTS**IR/DWV****Pin-to-Ground**Group 1

240-J-P-EP-ST-EL-01

RF086-24SP-505050-0304

10 Assemblies

Step	Description
1.	Interface Gaging <i>Note: Measure and record center contact recess from interface reference plane</i>
2.	IR (2) - Non Standard
3.	DWV at Test Voltage (1) - Non Standard Test Voltage = 500 VAC
4.	LLCR (3) - Non Standard <i>Note: Signal and ground.</i>
5.	Thermal Shock (4) - Non Standard
6.	IR (2) - Non Standard
7.	DWV at Test Voltage (1) - Non Standard Test Voltage = 500 VAC
8.	LLCR (3) - Non Standard Max Delta = 15 mOhm <i>Note: Signal and ground.</i>
9.	Interface Gaging <i>Note: Measure and record center contact recess from interface reference plane</i>

(1) DWV at Test Voltage = Other

Test Condition = 1 (Sea Level) Test voltage applied for 60 seconds
MIL-PRF-39012, Paragraph. 4.6.14 per MIL-STD-202-301

(2) IR = Other

Test Condition = 500V DC, 2 Minutes Max
MIL-PRF-39012, Paragraph 4.6.8 per MIL-STD-202-302

(3) LLCR = Other

Open Circuit Voltage = 20 mV Max
Test Current = 100 mA Max
MIL-PRF-39012, Paragraph 4.6.13 except current to be 100mA nominal and voltage to be 20 mV maximum.

(4) Thermal Shock = Other

Exposure Time at Temperature Extremes = 1/2 Hour
Test Condition = I (-65°C to +125°C)
Test Duration = test condition B except 10 cycles instead of 5.
MIL-PRF-39012, Paragraph. 4.6.17 per MIL-STD-202-107

FLOWCHARTS Continued**Mechanical Shock/Random Vibration/Event Detection**Group 1

240-J-P-EP-ST-EL-01

RF086-24SP-505050-0304

10 Assemblies

Step	Description
1.	Nanosecond Event Detection (Mechanical Shock) ⁽¹⁾
2.	Nanosecond Event Detection (Random Vibration) ⁽²⁾

(1) Nanosecond Event Detection (Mechanical Shock)

Use EIA-364-87 for Nanosecond Event Detection:

Test Condition = F (50 nanoseconds at 10 ohms)

Use EIA-364-27 for Mechanical Shock:

Test Condition = C (100 G Peak, 6 milliseconds, Half Sine)

Number of Shocks = 3 Per Direction, Per Axis, 18 Total

(2) Nanosecond Event Detection (Random Vibration)

Use EIA-364-87 for Nanosecond Event Detection:

Test Condition = F (50 nanoseconds at 10 ohms)

Use EIA-364-28 for Random Vibration:

Condition = VB (7.56 gRMS Average, 2 Hours/Axis)

FLOWCHARTS Continued**Center Contact Retention****Minimum Force**Group 1

240-J-P-EP-ST-EL-01

5 Assemblies

Minimum Force

*Note: Test I.A.W. MIL-PRF-39012 par.
4.6.9.*

Step Description

1. Measure Contact Recess @ Interface
2. Apply Minimum Force Onto Socket Face
Note: Applied Force = 4 lbf (17.8 N)
3. Apply Min Force Onto Contact In Opposite Direction
Note: Applied Force = 4 lbf (17.8 N)
4. Measure Contact Recess @ Interface

Center Contact CaptivationGroup 1

240-J-P-EP-ST-EL-01

5 Assemblies

Maximum Force.

*Note: This is a destructive test.
Apply force to the center socket contact
(push on contact from pin end of
assembly) and record maximum force at
captivation failure and note cause of
failure. Examples of failure; Contact
disengaged from internal dielectric
capture bead. Interface bushing
disengaged.*

Step Description

1. Apply Force On The Socket Center Contact
*Note: Crosshead speed range 0.5-
5.0 mm/min will be sufficient.
Maximum force is the load force
measured at captivation failure.*

ATTRIBUTE DEFINITIONS

The following is a brief, simplified description of attributes.

THERMAL SHOCK:

- 1) MIL-PRF-39012, paragraph. 4.6.17 per MIL-STD-202-107.
- 2) Test Condition I: -65°C to +125°C
- 3) Test Time: ½ hour dwell at each temperature extreme
- 4) Test Duration: test condition B except 10 Cycles instead of 5.
- 5) All test samples are pre-conditioned at ambient.
- 6) All test samples are exposed to environmental stressing in the mated condition.

LLCR:

- 1) MIL-PRF-39012, Paragraph 4.6.13 except current to be 100mA nominal and voltage to be 20 mV maximum.
- 2) A computer program, *LLCR 221.exe*, ensures repeatability for data acquisition.
- 3) The following guidelines are used to categorize the changes in LLCR as a result from stressing.
 - a. $\leq +5.0$ mOhms: -----Stable
 - b. +5.1 to +10.0 mOhms: -----Minor
 - c. +10.1 to +15.0 mOhms: -----Acceptable
 - d. +15.1 to +50.0 mOhms: -----Marginal
 - e. +50.1 to +1000 mOhms: -----Unstable
 - f. $>+1000$ mOhms: -----Open Failure

Center Contact Retention:

- 1) Apply 4 pounds force Onto Socket Face and Onto Contact in Opposite Direction.

Center Contact Captivation:

- 1) Apply force On the Socket Center Contact

ATTRIBUTE DEFINITIONS Continued

The following is a brief, simplified description of attributes

INSULATION RESISTANCE (IR):

To determine the resistance of insulation materials to leakage of current through or on the surface of these materials when a DC potential is applied.

- 1) PROCEDURE:
 - a. Reference document: MIL-PRF-39012, paragraph. 4.6.8 per MIL-STD-202-302.
 - b. Test Conditions:
 - i. Between Adjacent Contacts or Signal-to-Ground
 - ii. Electrification Time 2.0 minutes
 - iii. Test Voltage (500 VDC) corresponds to calibration settings for measuring resistances.
- 2) MEASUREMENTS:
- 3) When the specified test voltage is applied (VDC), the insulation resistance shall not be less than 5000 megohms.

DIELECTRIC WITHSTANDING VOLTAGE (DWV):

To determine if the sockets can operate at its rated voltage and withstand momentary over potentials due to switching, surges, and other similar phenomenon. Separate samples are used to evaluate the effect of environmental stresses so not to influence the readings from arcing that occurs during the measurement process.

- 1) PROCEDURE:
 - a. Reference document: MIL-PRF-39012, paragraph. 4.6.14 per MIL-STD-202-301.
 - b. Test Conditions:
 - i. Between Adjacent Contacts or Signal-to-Ground
 - ii. Barometric Test Condition 1(Sea Level) Test voltage applied for 60 seconds.
 - iii. Rate of Application 500 V/Sec
 - iv. Test Voltage (VAC) until breakdown occurs.
- 2) MEASUREMENTS/CALCULATIONS
 - a. The breakdown voltage shall be measured and recorded.
 - b. The dielectric withstanding voltage shall be recorded as 75% of the minimum breakdown voltage.
 - c. The working voltage shall be recorded as one-third (1/3) of the dielectric withstanding voltage (one-fourth of the breakdown voltage).

VIBRATION:

- 1) Reference document: EIA-364-28, *Vibration Test Procedure for Electrical Connectors*
- 2) Test Condition V, Letter B
- 3) Power Spectral Density: 0.04 G² / Hz
- 4) G 'RMS': 7.56
- 5) Frequency: 50 to 2000 Hz
- 6) Duration: 2.0 Hours per axis (3 axis total)

NANOSECOND-EVENT DETECTION:

- 1) Reference document: EIA-364-87, *Nanosecond-Event Detection for Electrical Connectors*
- 2) Prior to test, the samples were characterized to assure the low nanosecond event being monitored will trigger the detector.
- 3) After characterization it was determined the test samples could be monitored for 50 nanosecond events

RESULTS

Center Contact Captivation

- Min -----54.10 lbs
- Max -----56.24 lbs

Insulation Resistance minimums, IR

Pin to Ground

- **Initial**
 - Mated-----45000 Meg Ω ----- Passed
- **Thermal Shock**
 - Mated-----45000 Meg Ω ----- Passed

Dielectric Withstanding Voltage minimums, DWV

- Test Voltage -----500 VAC

Pin to Ground

- Initial DWV -----Passed
- Thermal DWV -----Passed

Interface Gaging

IR/DWV Group

Initial

- Min ----- 0.0015 inch (0.038 mm)
- Max ----- 0.0030 inch (0.076 mm)

After Retention

- Min ----- 0.0015 inch (0.038 mm)
- Max ----- 0.0030 inch (0.076 mm)

Center Contact Retention Group

Initial

- Min ----- 0.0015 inch (0.038 mm)
- Max ----- 0.0020 inch (0.051 mm)

After Retention

- Min ----- 0.0010 inch (0.025 mm)
- Max ----- 0.0020 inch (0.051 mm)

RESULTS Continued

LLCR IR/DWV (10 ground and 10 signal LLCR test points)

Ground pin

- **Initial** ----- 11.89 mOhms Max
- **Thermal Shock**
 - **<= +5.0 mOhms**----- 10 Points ----- Stable
 - **+5.1 to +10.0 mOhms** -----0 Points ----- Minor
 - **+10.1 to +15.0 mOhms** -----0 Points ----- Acceptable
 - **+15.1 to +50.0 mOhms** -----0 Points ----- Marginal
 - **+50.1 to +1000 mOhms**-----0 Points ----- Unstable
 - **>+1000 mOhms**-----0 Points ----- Open Failure

Signal pin

- **Initial** ----- 35.52 mOhms Max
- **Thermal Shock**
 - **<= +5.0 mOhms**----- 10 Points ----- Stable
 - **+5.1 to +10.0 mOhms** -----0 Points ----- Minor
 - **+10.1 to +15.0 mOhms** -----0 Points ----- Acceptable
 - **+15.1 to +50.0 mOhms** -----0 Points ----- Marginal
 - **+50.1 to +1000 mOhms**-----0 Points ----- Unstable
 - **>+1000 mOhms**-----0 Points ----- Open Failure

DATA SUMMARIES

INSULATION RESISTANCE (IR):

Pin to Ground	
	Mated
Minimum	240/RF086
Initial	45000
Thermal Shock	45000

DIELECTRIC WITHSTANDING VOLTAGE (DWV):

Voltage Rating Summary	
Minimum	240/RF086
Test Voltage	500

Pin to Ground	
Initial Test Voltage	Pass
After Thermal Shock Test Voltage	Pass

Center Contact Captivation Force:

	Force (lbs)	Force (N)
Minimum	54.10	240.64
Maximum	56.24	250.16
Average	55.32	246.05

DATA SUMMARIES Continued**Interface Gaging
IR/DWV Group**

Gaging (0.003-0.000) (inch)			
240	Initial	Thermal Shock	Delta
1	0.0020	0.0015	0.0005
2	0.0025	0.0025	0.0000
3	0.0020	0.0015	0.0005
4	0.0025	0.0030	0.0005
5	0.0030	0.0020	0.0010
6	0.0015	0.0015	0.0000
7	0.0020	0.0020	0.0000
8	0.0015	0.0020	0.0005
9	0.0020	0.0020	0.0000
10	0.0020	0.0025	0.0005

Center Contact Retention Group

Gaging (0.003-0.000) (inch)			
240	Initial	Apply 4 Lbs Force	Delta
1	0.0020	0.0020	0.0000
2	0.0015	0.0010	0.0005
3	0.0015	0.0015	0.0000
4	0.0020	0.0010	0.0010
5	0.0015	0.0020	0.0005

DATA SUMMARIES Continued

LLCR IR/DWV:

- 1) A total of 10 signal and 10 ground points were measured.
- 2) MIL-PRF-39012, Paragraph 4.6.13 except current to be 100mA nominal and voltage to be 20 mV maximum.
- 3) A computer program, LLCR 221.exe, ensures repeatability for data acquisition.
- 4) The following guidelines are used to categorize the changes in LLCR as a result from stressing.
 - a. $\leq +5.0$ mOhms: -----Stable
 - b. $+5.1$ to $+10.0$ mOhms:-----Minor
 - c. $+10.1$ to $+15.0$ mOhms: -----Acceptable
 - d. $+15.1$ to $+50.0$ mOhms: -----Marginal
 - e. $+50.1$ to $+1000$ mOhms: -----Unstable
 - f. $>+1000$ mOhms:-----Open Failure

LLCR Measurement Summaries by Pin Type				
Date	3/6/2023	3/8/2023		
Room Temp (Deg C)	22	22		
Rel Humidity (%)	50	52		
Technician	Kason He	Kason He		
mOhm values	Actual	Delta Thermal Shock		
	Initial			
Pin Type: Signal 1				
Average	33.85	1.24		
St. Dev.	0.75	0.54		
Min	33.02	0.31		
Max	35.52	2.18		
Summary Count	10	10		
Total Count	10	10		
Pin Type: GND 1				
Average	11.30	0.92		
St. Dev.	0.43	1.20		
Min	10.61	0.04		
Max	11.89	4.09		
Summary Count	10	10		
Total Count	10	10		

LLCR Delta Count by Category						
	Stable	Minor	Acceptable	Marginal	Unstable	Open
mOhms	≤ 5	$>5 \ \& \ \leq 10$	$>10 \ \& \ \leq 15$	$>15 \ \& \ \leq 50$	$>50 \ \& \ \leq 1000$	>1000
After Thermal Shock	20	0	0	0	0	0

DATA SUMMARIES Continued**Nanosecond Event Detection:**

Shock and Vibration Event Detection Summary	
Contacts tested	20
Test Condition	C, 100g's, 6ms, Half-Sine
Shock Events	0
Test Condition	V-B, 7.56 rms g
Vibration Events	0
Total Events	0

EQUIPMENT AND CALIBRATION SCHEDULES**Equipment #:** HZ-TCT-01**Description:** Normal force analyzer**Manufacturer:** Mecmesin Multitester**Model:** Mecmesin Multitester 2.5-i**Serial #:** 08-1049-04**Accuracy:** Last Cal: 3/3/2023, Next Cal: 3/2/2024**Equipment #:** HZ-TSC-01**Description:** Vertical Thermal Shock Chamber**Manufacturer:** Cincinnatti Sub Zero**Model:** VTS-3-6-6-SC/AC**Serial #:** 10-VT14994**Accuracy:** See Manual

... Last Cal: 04/16/2022, Next Cal: 04/15/2023

Equipment #: DG-HPT-01**Description:** Hipot Safety Tester**Manufacturer:** Vitrek**Model:** V73**Serial #:** 025866**Accuracy:**

... Last Cal: 04/16/2022, Next Cal: 04/15/2023

Equipment #: HZ-MO-05**Description:** Micro-ohmmeter**Manufacturer:** Keithley**Model:** 3706**Serial #:** 1285188**Accuracy:** Last Cal: 12/17/2022, Next Cal: 12/16/2023**Equipment #:** MO-11**Description:** Switch/Multimeter**Manufacturer:** Keithley**Model:** 3706**Serial #:** 120169**Accuracy:** See Manual

... Last Cal: 08/21/2022, Next Cal: 08/21/2023

Equipment #: SVC-01**Description:** Shock & Vibration Table**Manufacturer:** Data Physics**Model:** LE-DSA-10-20K**Serial #:** 10037**Accuracy:** See Manual

... Last Cal: 11/31/2022, Next Cal: 11/31/2023

EQUIPMENT AND CALIBRATION SCHEDULES Continued**Equipment #:** ACLM-01**Description:** Accelerometer**Manufacturer:** PCB Piezotronics**Model:** 352C03**Serial #:** 115819**Accuracy:** See Manual

... Last Cal: 07/09/2022, Next Cal: 07/09/2023

Equipment #: ED-03**Description:** Event Detector**Manufacturer:** Analysis Tech**Model:** 32EHD**Serial #:** 1100604**Accuracy:** See Manual

... Last Cal: 06/04/2022, Next Cal: 06/04/2023