

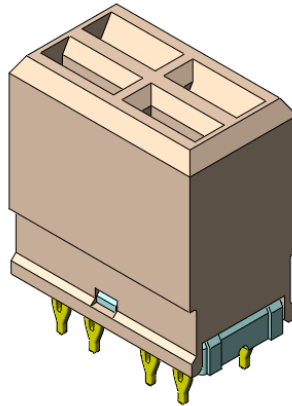

Project Number: Design Qualification Test Report	Tracking Code: CR-959104_Report_Rev_1
Requested by: Leo Lee	Date: 4/26/2024
Part #: HPTS-3-S-D-VT/SUB-HPTT-3-S-6-6-D-RA	
Part description: HPTS/SUB-HPTT	Tech: Peter Chen
Test Start: 7/15/2023	Test Completed: 8/17/2023

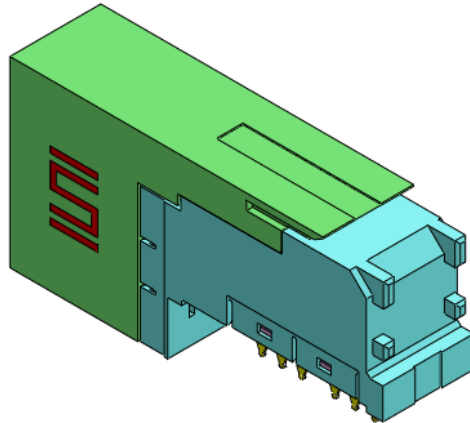

DESIGN QUALIFICATION TEST REPORT
HPTS/SUB-HPTT
HPTS-3-S-D-VT/SUB-HPTT-3-S-6-6-D-RA

REVISION HISTORY

DATA	REV.NUM.	DESCRIPTION	ENG
9/27/2023	1	Initial test	PC

CERTIFICATION

All instruments and measuring equipment were calibrated to National Institute for Standards and Technology (NIST) traceable standards according to ISO 10012-1 and ANSI/NCSL 2540-1, as applicable.

All contents contained herein are the property of Samtec. No portion of this report, in part or in full shall be reproduced without prior written approval of Samtec.

SCOPE

To perform the following tests: Design Qualification test. Please see test plan.

APPLICABLE DOCUMENTS

Standards: EIA Publication 364

TEST SAMPLES AND PREPARATION

- 1) All materials were manufactured in accordance with the applicable product specification.
- 2) All test samples were identified and encoded to maintain traceability throughout the test sequences.
- 3) After soldering, the parts to be used for LLCR and DWV/IR testing were cleaned according to CO-SC-WI-3029.
- 4) Either an automated cleaning procedure or an ultrasonic cleaning procedure may be used.
- 5) The automated procedure is used with aqueous compatible soldering materials.
- 6) Parts not intended for testing LLCR and DWV/IR are visually inspected and cleaned if necessary.
- 7) Any additional preparation will be noted in the individual test sequences.
- 8) Solder Information: Lead Free
- 9) Samtec Test PCBs used: PCB-112895-TST.

FLOWCHARTS Continued

IR/DWVPin-to-Pin

Group 1
HPTS-3-S-D-VT
SUB-HPTT-3-S-6-6-D-RA
2 Assemblies
Samtec VT To Samtec RA

Step	Description
1.	DWV Breakdown ⁽³⁾

Group 2
HPTS-3-S-D-VT
928-3000-D8H
2 Assemblies
Samtec VT To Amphenol RA

Step	Description
1.	DWV Breakdown ⁽³⁾

Group 3
968-3200-A1H
SUB-HPTT-3-S-6-6-D-RA
2 Assemblies
Amphenol VT To Samtec RA

Step	Description
1.	DWV Breakdown ⁽³⁾

Group 4
HPTS-3-S-D-VT

2 Assemblies
Samtec VT Only

Step	Description
1.	DWV Breakdown ⁽³⁾

Group 5
SUB-HPTT-3-S-6-6-D-RA

2 Assemblies
Samtec RA Only

Step	Description
1.	DWV Breakdown ⁽²⁾

Group 6
HPTS-3-S-D-VT
SUB-HPTT-3-S-6-6-D-RA
2 Assemblies
Samtec VT To Samtec RA

Step	Description
1.	IR ⁽⁵⁾
2.	DWV at Test Voltage ⁽¹⁾
3.	Thermal Shock ⁽⁶⁾
4.	IR ⁽⁵⁾
5.	DWV at Test Voltage ⁽¹⁾
6.	Humidity ⁽⁴⁾
7.	IR ⁽⁵⁾
8.	DWV at Test Voltage ⁽¹⁾

Group 7
HPTS-3-S-D-VT
928-3000-D8H
2 Assemblies
Samtec VT To Amphenol RA

Step	Description
1.	IR ⁽⁵⁾
2.	DWV at Test Voltage ⁽¹⁾
3.	Thermal Shock ⁽⁶⁾
4.	IR ⁽⁵⁾
5.	DWV at Test Voltage ⁽¹⁾
6.	Humidity ⁽⁴⁾
7.	IR ⁽⁵⁾
8.	DWV at Test Voltage ⁽¹⁾

Group 8
968-3200-A1H
SUB-HPTT-3-S-6-6-D-RA
2 Assemblies
Amphenol VT To Samtec RA

Step	Description
1.	IR ⁽⁵⁾
2.	DWV at Test Voltage ⁽¹⁾
3.	Thermal Shock ⁽⁶⁾
4.	IR ⁽⁵⁾
5.	DWV at Test Voltage ⁽¹⁾
6.	Humidity ⁽⁴⁾
7.	IR ⁽⁵⁾
8.	DWV at Test Voltage ⁽¹⁾

Group 17
968-3200-A1H
928-3000-D8H
2 Assemblies
Amphenol VT To Amphenol RA

Step	Description
1.	DWV Breakdown ⁽³⁾

Group 18
968-3200-A1H

2 Assemblies
Amphenol VT Only

Step	Description
1.	DWV Breakdown ⁽³⁾

Group 19
928-3000-D8H

2 Assemblies
Amphenol RA Only

Step	Description
1.	DWV Breakdown ⁽²⁾

Group 20
968-3200-A1H
928-3000-D8H
2 Assemblies
Amphenol VT To Amphenol RA

Step	Description
1.	IR ⁽⁵⁾
2.	DWV at Test Voltage ⁽¹⁾
3.	Thermal Shock ⁽⁶⁾
4.	IR ⁽⁵⁾
5.	DWV at Test Voltage ⁽¹⁾
6.	Humidity ⁽⁴⁾
7.	IR ⁽⁵⁾
8.	DWV at Test Voltage ⁽¹⁾

Row-to-Row

Group 9
HPTS-3-S-D-VT
SUB-HPTT-3-S-6-6-D-RA
2 Assemblies
Samtec VT To Samtec RA

Step	Description
1.	DWV Breakdown ⁽³⁾

Group 10
HPTS-3-S-D-VT
928-3000-D8H
2 Assemblies
Samtec VT To Amphenol RA

Step	Description
1.	DWV Breakdown ⁽³⁾

Group 11
968-3200-A1H
SUB-HPTT-3-S-6-6-D-RA
2 Assemblies
Amphenol VT To Samtec RA

Step	Description
1.	DWV Breakdown ⁽³⁾

Group 12
HPTS-3-S-D-VT

2 Assemblies
Samtec VT Only

Step	Description
1.	DWV Breakdown ⁽³⁾

FLOWCHARTS Continued

Group 13 SUB-HPTT-3-S-6-6-D-RA 2 Assemblies Samtec RA Only	Group 14 HPTS-3-S-D-VT SUB-HPTT-3-S-6-6-D-RA 2 Assemblies Samtec VT To Samtec RA	Group 15 HPTS-3-S-D-VT 928-3000-D8H 2 Assemblies Samtec VT To Amphenol RA	Group 16 968-3200-A1H SUB-HPTT-3-S-6-6-D-RA 2 Assemblies Amphenol VT To Samtec RA
Step Description	Step Description	Step Description	Step Description
1. DWV Breakdown ⁽²⁾	1. IR ⁽⁵⁾ 2. DWV at Test Voltage _{e(1)} 3. Thermal Shock ⁽⁶⁾ 4. IR ⁽⁵⁾ 5. DWV at Test Voltage _{e(1)} 6. Humidity ⁽⁴⁾ 7. IR ⁽⁵⁾ 8. DWV at Test Voltage _{e(1)}	1. IR ⁽⁵⁾ 2. DWV at Test Voltage _{e(1)} 3. Thermal Shock ⁽⁶⁾ 4. IR ⁽⁵⁾ 5. DWV at Test Voltage _{e(1)} 6. Humidity ⁽⁴⁾ 7. IR ⁽⁵⁾ 8. DWV at Test Voltage _{e(1)}	1. IR ⁽⁵⁾ 2. DWV at Test Voltage _{e(1)} 3. Thermal Shock ⁽⁶⁾ 4. IR ⁽⁵⁾ 5. DWV at Test Voltage _{e(1)} 6. Humidity ⁽⁴⁾ 7. IR ⁽⁵⁾ 8. DWV at Test Voltage _{e(1)}
Group 21 968-3200-A1H 928-3000-D8H 2 Assemblies Amphenol VT To Amphenol RA	Group 22 968-3200-A1H 2 Assemblies Amphenol VT Only	Group 23 928-3000-D8H 2 Assemblies Amphenol RA Only	Group 24 968-3200-A1H 928-3000-D8H 2 Assemblies Amphenol VT To Amphenol RA
Step Description	Step Description	Step Description	Step Description
1. DWV Breakdown ⁽³⁾	1. DWV Breakdown ⁽³⁾	1. DWV Breakdown ⁽²⁾	1. IR ⁽⁵⁾ 2. DWV at Test Voltage _{e(1)} 3. Thermal Shock ⁽⁶⁾ 4. IR ⁽⁵⁾ 5. DWV at Test Voltage _{e(1)} 6. Humidity ⁽⁴⁾ 7. IR ⁽⁵⁾ 8. DWV at Test Voltage _{e(1)}

- (1) DWV at Test Voltage = EIA-364-20
 Test Condition = 1 (Sea Level)
 DWV test voltage is equal to 75% of the lowest breakdown voltage
 Test voltage applied for 60 seconds
- (2) DWV Breakdown = EIA-364-20
 Test Condition = 1 (Sea Level)
 DWV test voltage is equal to 75% of the lowest breakdown voltage
 Test voltage applied for 60 seconds
- (3) DWV Breakdown = EIA-364-20
 Test Condition = 1 (Sea Level)
 DWV test voltage is equal to 75% of the lowest breakdown voltage
 Test voltage applied for 60 seconds
- (4) Humidity = EIA-364-31
 Test Condition = B (240 Hours)
 Test Method = III (+25°C to +65°C @ 90% RH to 98% RH)
 Test Exceptions: ambient pre-condition and delete steps 7a and 7b
- (5) IR = EIA-364-21
 Test Condition = 500 Vdc, 2 Minutes Max
- (6) Thermal Shock = EIA-364-32
 Exposure Time at Temperature Extremes = 1/2 Hour
 Method A, Test Condition = I (-55°C to +85°C)
 Test Duration = A-3 (100 Cycles)

FLOWCHARTS Continued**Current Carrying Capacity**

Group 1
HPTS-3-S-D-VT
SUB-HPTT-3-S-6-6-D-RA
2 Pins Powered
Samtec VT To Samtec RA

Step	Description
1.	CCC ⁽¹⁾ Number of Positions = 1 Rows = 2

Group 2
HPTS-3-S-D-VT
928-3000-D8H
2 Pins Powered
Samtec VT To Amphenol RA

Step	Description
1.	CCC ⁽¹⁾ Number of Positions = 1 Rows = 2

Group 3
968-3200-A1H
SUB-HPTT-3-S-6-6-D-RA
2 Pins Powered
Amphenol VT To Samtec RA

Step	Description
1.	CCC ⁽¹⁾ Number of Positions = 1 Rows = 2

Group 4
HPTS-3-S-D-VT
SUB-HPTT-3-S-6-6-D-RA
4 Pins Powered
Samtec VT To Samtec RA

Step	Description
1.	CCC ⁽¹⁾ Number of Positions = 2 Rows = 2

Group 5
HPTS-3-S-D-VT
928-3000-D8H
4 Pins Powered
Samtec VT To Amphenol RA

Step	Description
1.	CCC ⁽¹⁾ Number of Positions = 2 Rows = 2

Group 6
968-3200-A1H
SUB-HPTT-3-S-6-6-D-RA
4 Pins Powered
Amphenol VT To Samtec RA

Step	Description
1.	CCC ⁽¹⁾ Number of Positions = 2 Rows = 2

Group 7
968-3200-A1H
928-3000-D8H
2 Pins Powered
Amphenol VT To Amphenol RA

Step	Description
1.	CCC ⁽¹⁾ Rows = 2 Number of Positions = 1

Group 8
968-3200-A1H
928-3000-D8H
4 Pins Powered
Amphenol VT To Amphenol RA

Step	Description
1.	CCC ⁽¹⁾ Rows = 2 Number of Positions = 2

(1) CCC = EIA-364-70

Method 2, Temperature Rise Versus Current Curve

(TIN PLATING) - Tabulate calculated current at RT, 65°C, 75°C and 95°C after derating 20% and based on 105°C

(GOLD PLATING) - Tabulate calculated current at RT, 85°C, 95°C and 115°C after derating 20% and based on 125°C

ATTRIBUTE DEFINITIONS

The following is a brief, simplified description of attributes.

THERMAL:

- 1) EIA-364-17, *Temperature Life with or without Electrical Load Test Procedure for Electrical Connectors*.
- 2) Test Condition at 105° C.
- 3) Test Time Condition B for 250 hours.
- 4) All test samples are pre-conditioned at ambient.
- 5) All test samples are exposed to environmental stressing in the mated condition.

THERMAL SHOCK:

- 1) EIA-364-32, *Thermal Shock (Temperature Cycling) Test Procedure for Electrical Connectors*.
- 2) Test Condition I: -55°C to +85°C
- 3) Test Time: ½ hour dwell at each temperature extreme
- 4) Number of Cycles: 100
- 5) All test samples are pre-conditioned at ambient.
- 6) All test samples are exposed to environmental stressing in the mated condition.

HUMIDITY:

- 1) Reference document: EIA-364-31, *Humidity Test Procedure for Electrical Connectors*.
- 2) Test Condition B, 240 Hours.
- 3) Method III, +25° C to + 65° C, 90% to 98% Relative Humidity excluding sub-cycles 7a and 7b.
- 4) All samples are pre-conditioned at ambient.
- 5) All test samples are exposed to environmental stressing in the mated condition.

LLCR:

- 1) EIA-364-23, *Low Level Contact Resistance Test Procedure for Electrical Connectors and Sockets*.
- 2) A computer program, *LLCR 221.exe*, ensures repeatability for data acquisition.
- 3) The following guidelines are used to categorize the changes in LLCR as a result from stressing
 - a. $\leq +1.0$ mOhms: -----Stable
 - b. +1.1 to +2.0 mOhms: -----Minor
 - c. +2.1 to +5.0 mOhms: -----Acceptable
 - d. +5.1 to +15.0 mOhms:-----Marginal
 - e. +15.1 to +1000 mOhms:-----Unstable
 - f. $>+1000$ mOhms:-----Open Failure

GAS TIGHT:

To provide method for evaluating the ability of the contacting surfaces in preventing penetration of harsh vapors which might lead to oxide formation that may degrade the electrical performance of the contact system.

- 1) EIA-364-23, *Low Level Contact Resistance Test Procedure for Electrical Connectors and Sockets*.
- 2) A computer program, *LLCR 221.exe*, ensures repeatability for data acquisition.
- 3) The following guidelines are used to categorize the changes in LLCR as a result from stressing
 - a. $\leq +1.0$ mOhms:-----Stable
 - b. +1.1 to +2.0 mOhms: -----Minor
 - c. +2.1 to +5.0 mOhms: -----Acceptable
 - d. +5.1 to +15.0 mOhms:-----Marginal
 - e. +15.1 to +1000 mOhms:-----Unstable
 - f. $>+1000$ mOhms:-----Open Failure

ATTRIBUTE DEFINITIONS Continued

The following is a brief, simplified description of attributes

TEMPERATURE RISE (Current Carrying Capacity, CCC):

- 1) EIA-364-70, *Temperature Rise versus Current Test Procedure for Electrical Connectors and Sockets*.
- 2) When current passes through a contact, the temperature of the contact increases as a result of I^2R (resistive) heating.
- 3) The number of contacts being investigated plays a significant part in power dissipation and therefore temperature rise.
- 4) The size of the temperature probe can affect the measured temperature.
- 5) Copper traces on PC boards will contribute to temperature rise:
 - a. Self-heating (resistive)
 - b. Reduction in heat sink capacity affecting the heated contacts
- 6) A de-rating curve, usually 20%, is calculated.
- 7) Calculated de-rated currents at four temperature points are reported:
 - a. Ambient
 - b. 85° C
 - c. 95° C
 - d. 115° C
- 8) Typically, neighboring contacts (in close proximity to maximize heat buildup) are energized.
- 9) The thermocouple (or temperature measuring probe) will be positioned at a location to sense the maximum temperature in the vicinity of the heat generation area.
- 10) A computer program, *TR 803.exe*, ensures accurate stability for data acquisition.
- 11) Hook-up wire cross section is larger than the cross section of any connector leads/PC board traces, jumpers, etc.
- 12) Hook-up wire length is longer than the minimum specified in the referencing standard.

NORMAL FORCE (FOR CONTACTS TESTED IN THE HOUSING):

- 1) Reference document: EIA-364-04, *Normal Force Test Procedure for Electrical Connectors*.
- 2) The contacts shall be tested in the connector housing.
- 3) If necessary, a “window” shall be made in the connector body to allow a probe to engage and deflect the contact at the same attitude and distance (plus 0.05 mm [0.002”]) as would occur in actual use.
- 4) The connector housing shall be placed in a holding fixture that does not interfere with or otherwise influence the contact force or deflection.
- 5) Said holding fixture shall be mounted on a floating, adjustable, X-Y table on the base of the Dillon TC², computer controlled test stand with a deflection measurement system accuracy of 5.0 μm (0.0002”).
- 6) The nominal deflection rate shall be 5 mm (0.2”)/minute.
- 7) Unless otherwise noted a minimum of five contacts shall be tested.
- 8) The force/deflection characteristic to load and unload each contact shall be repeated five times.
- 9) The system shall utilize the TC² software in order to acquire and record the test data.
- 10) The permanent set of each contact shall be measured within the TC² software.
- 11) The acquired data shall be graphed with the deflection data on the X-axis and the force data on the Y-axis and a print out will be stored with the Tracking Code paperwork.

ATTRIBUTE DEFINITIONS Continued

The following is a brief, simplified description of attributes

- 4) Procedure:
- a. Reference document: EIA-364-36, *Test Procedure for Determination of Gas-Tight Characteristics for Electrical Connectors, Sockets and/or Contact Systems*.
 - b. Test Conditions:
 - i. Class II--- Mated pairs of contacts assembled to their plastic housings.
 - ii. Reagent grade Nitric Acid shall be used of sufficient volume to saturate the test chamber
 - iii. The ratio of the volume of the test chamber to the surface area of the acid shall be 10:1.
 - iv. The chamber shall be saturated with the vapor for at least 15 minutes before samples are added.
 - v. Exposure time, 55 to 65 minutes.
 - vi. The samples shall be no closer to the chamber walls than 1 inches and no closer to the surface of the acid than 3 inches.
 - vii. The samples shall be dried after exposure for a minimum of 1 hour.
 - viii. Drying temperature 50° C
 - ix. The final LLCR shall be conducted within 1 hour after drying.

INSULATION RESISTANCE (IR):

To determine the resistance of insulation materials to leakage of current through or on the surface of these materials when a DC potential is applied.

- 1) PROCEDURE:
 - a. Reference document: EIA-364-21, *Insulation Resistance Test Procedure for Electrical Connectors*.
 - b. Test Conditions:
 - i. Between Adjacent Contacts or Signal-to-Ground
 - ii. Electrification Time 2.0 minutes
 - iii. Test Voltage (500 VDC) corresponds to calibration settings for measuring resistances.
- 2) MEASUREMENTS:
- 3) When the specified test voltage is applied (VDC), the insulation resistance shall not be less than 5000 megohms.

DIELECTRIC WITHSTANDING VOLTAGE (DWV):

To determine if the sockets can operate at its rated voltage and withstand momentary over potentials due to switching, surges, and other similar phenomenon. Separate samples are used to evaluate the effect of environmental stresses so not to influence the readings from arcing that occurs during the measurement process.

- 1) PROCEDURE:
 - a. Reference document: EIA-364-20, *Withstanding Voltage Test Procedure for Electrical Connectors*.
 - b. Test Conditions:
 - i. Between Adjacent Contacts or Signal-to-Ground
 - ii. Barometric Test Condition 1
 - iii. Rate of Application 500 V/Sec
 - iv. Test Voltage (VAC) until breakdown occurs
- 2) MEASUREMENTS/CALCULATIONS
 - a. The breakdown voltage shall be measured and recorded.
 - b. The dielectric withstanding voltage shall be recorded as 75% of the minimum breakdown voltage.
 - c. The working voltage shall be recorded as one-third (1/3) of the dielectric withstanding voltage (one-fourth of the breakdown voltage).

RESULTS

Temperature Rise, CCC at a 20% de-rating

Samtec VT To Samtec RA

- CCC for a 30°C Temperature Rise-----13.6 A per contact with 2 contact (2x 1) powered.
- CCC for a 30°C Temperature Rise-----10.8 A per contact with 4 contacts (2 x 2) powered.

Samtec VT To Amphenol RA

- CCC for a 30°C Temperature Rise-----13.5 A per contact with 2 contacts (2x 1) powered.
- CCC for a 30°C Temperature Rise-----11.1 A per contact with 4 contacts (2 x 2) powered.

Amphenol VT To Samtec RA

- CCC for a 30°C Temperature Rise-----12.8 A per contact with 2 contacts (2 x 1) powered.
- CCC for a 30°C Temperature Rise-----10.6 A per contact with 4 contacts (2 x 2) powered.

Amphenol VT To Amphenol RA

- CCC for a 30°C Temperature Rise-----12.9 A per contact with 2 contacts (2 x 1) powered.
- CCC for a 30°C Temperature Rise-----10.7 A per contact with 4 contacts (2 x 2) powered.

Normal Force at 0.0100 inches deflection

Samtec VT To Samtec RA

Long Pin

- Initial
 - Min -----32.90 gf Set ---- 0.0000 inch.
 - Max -----35.90 gf Set ---- 0.0002 inch.
- Thermal
 - Min -----27.90 gf Set----- 0.0007 inch.
 - Max -----31.80 gf Set----- 0.0014 inch.

Short Pin

- Initial
 - Min -----49.80 gf Set ---- 0.0000 inch.
 - Max -----60.30 gf Set ---- 0.0007 inch.
- Thermal
 - Min -----45.40 gf Set----- 0.0004 inch.
 - Max -----52.40 gf Set----- 0.0015 inch.

Samtec VT To Amphenol RA

Long Pin

- Initial
 - Min -----38.40 gf Set ---- 0.0000 inch.
 - Max -----42.70 gf Set ---- 0.0002 inch.
- Thermal
 - Min -----30.40 gf Set----- 0.0002 inch.
 - Max -----35.20 gf Set----- 0.0015 inch.

Short Pin

- Initial
 - Min -----56.00 gf Set ---- 0.0000 inch.
 - Max -----72.00 gf Set ---- 0.0016 inch.
- Thermal
 - Min -----43.60 gf Set----- 0.0008 inch.
 - Max -----57.40 gf Set----- 0.0019 inch.

RESULTS Continued

Amphenol VT To Samtec RA

Long Pin

- **Initial**
 - **Min** -----32.20 gf **Set** ---- 0.0000 inch.
 - **Max** -----38.20 gf **Set** ---- 0.0003 inch.
- **Thermal**
 - **Min** -----28.10 gf **Set** ---- 0.0007 inch.
 - **Max** -----32.10 gf **Set** ---- 0.0011 inch.

Short Pin

- **Initial**
 - **Min** -----44.00 gf **Set** ---- 0.0000 inch.
 - **Max** -----59.30 gf **Set** ---- 0.0028 inch.
- **Thermal**
 - **Min** -----45.30 gf **Set** ---- 0.0001 inch.
 - **Max** -----50.90 gf **Set** ---- 0.0014 inch.

Amphenol VT To Amphenol RA

Long Pin

- **Initial**
 - **Min** -----32.20 gf **Set** ---- 0.0000 inch.
 - **Max** -----38.20 gf **Set** ---- 0.0003 inch.
- **Thermal**
 - **Min** -----28.10 gf **Set** ---- 0.0007 inch.
 - **Max** -----32.10 gf **Set** ---- 0.0011 inch.

Short Pin

- **Initial**
 - **Min** -----44.00 gf **Set** ---- 0.0000 inch.
 - **Max** -----59.30 gf **Set** ---- 0.0028 inch.
- **Thermal**
 - **Min** -----45.30 gf **Set** ---- 0.0001 inch.
 - **Max** -----50.90 gf **Set** ---- 0.0014 inch.

RESULTS Continued

Insulation Resistance minimums, IR

Samtec VT To Samtec RA

Pin to Pin

- **Initial**
 - Mated-----45000 Meg Ω ----- Passed
 - Unmated -----45000 Meg Ω ----- Passed
- **Thermal Shock**
 - Mated-----45000 Meg Ω ----- Passed
 - Unmated -----45000 Meg Ω ----- Passed
- **Humidity**
 - Mated-----45000 Meg Ω ----- Passed
 - Unmated -----45000 Meg Ω ----- Passed

Row to Row

- **Initial**
 - Mated-----45000 Meg Ω ----- Passed
 - Unmated -----45000 Meg Ω ----- Passed
- **Thermal Shock**
 - Mated-----45000 Meg Ω ----- Passed
 - Unmated -----45000 Meg Ω ----- Passed
- **Humidity**
 - Mated-----45000 Meg Ω ----- Passed
 - Unmated -----45000 Meg Ω ----- Passed

Samtec VT To Amphenol RA

Pin to Pin

- **Initial**
 - Mated-----45000 Meg Ω ----- Passed
 - Unmated -----45000 Meg Ω ----- Passed
- **Thermal Shock**
 - Mated-----45000 Meg Ω ----- Passed
 - Unmated -----45000 Meg Ω ----- Passed
- **Humidity**
 - Mated-----45000 Meg Ω ----- Passed
 - Unmated -----45000 Meg Ω ----- Passed

Row to Row

- **Initial**
 - Mated-----45000 Meg Ω ----- Passed
 - Unmated -----45000 Meg Ω ----- Passed
- **Thermal Shock**
 - Mated-----45000 Meg Ω ----- Passed
 - Unmated -----45000 Meg Ω ----- Passed
- **Humidity**
 - Mated-----45000 Meg Ω ----- Passed
 - Unmated -----45000 Meg Ω ----- Passed

RESULTS Continued**Amphenol VT To Samtec RA****Pin to Pin**

- **Initial**
 - Mated -----45000 Meg Ω ----- Passed
 - Unmated -----45000 Meg Ω ----- Passed
- **Thermal Shock**
 - Mated -----45000 Meg Ω ----- Passed
 - Unmated -----45000 Meg Ω ----- Passed
- **Humidity**
 - Mated -----45000 Meg Ω ----- Passed
 - Unmated -----45000 Meg Ω ----- Passed

Row to Row

- **Initial**
 - Mated -----45000 Meg Ω ----- Passed
 - Unmated -----45000 Meg Ω ----- Passed
- **Thermal Shock**
 - Mated -----45000 Meg Ω ----- Passed
 - Unmated -----45000 Meg Ω ----- Passed
- **Humidity**
 - Mated -----45000 Meg Ω ----- Passed
 - Unmated -----45000 Meg Ω ----- Passed

Amphenol VT To Amphenol RA**Pin to Pin**

- **Initial**
 - Mated -----45000 Meg Ω ----- Passed
 - Unmated -----45000 Meg Ω ----- Passed
- **Thermal Shock**
 - Mated -----45000 Meg Ω ----- Passed
 - Unmated -----45000 Meg Ω ----- Passed
- **Humidity**
 - Mated -----45000 Meg Ω ----- Passed
 - Unmated -----45000 Meg Ω ----- Passed

Row to Row

- **Initial**
 - Mated -----45000 Meg Ω ----- Passed
 - Unmated -----45000 Meg Ω ----- Passed
- **Thermal Shock**
 - Mated -----45000 Meg Ω ----- Passed
 - Unmated -----45000 Meg Ω ----- Passed
- **Humidity**
 - Mated -----45000 Meg Ω ----- Passed
 - Unmated -----45000 Meg Ω ----- Passed

RESULTS Continued**Dielectric Withstanding Voltage minimums, DWV****Samtec VT To Samtec RA**

- **Minimums**
 - Breakdown Voltage----- 2555 VAC
 - Test Voltage ----- 1920 VAC
 - Working Voltage -----635 VAC

Pin to Pin

- Initial DWV -----Passed
- Thermal DWV-----Passed
- Humidity DWV-----Passed

Row to Row

- Initial DWV -----Passed
- Thermal DWV-----Passed
- Humidity DWV-----Passed

Samtec VT To Amphenol RA

- **Minimums**
 - Breakdown Voltage----- 1529 VAC
 - Test Voltage ----- 1150 VAC
 - Working Voltage -----380 VAC

Pin to Pin

- Initial DWV -----Passed
- Thermal DWV-----Passed
- Humidity DWV-----Passed

Row to Row

- Initial DWV -----Passed
- Thermal DWV-----Passed
- Humidity DWV-----Passed

Amphenol VT To Samtec RA

- **Minimums**
 - Breakdown Voltage----- 1399VAC
 - Test Voltage ----- 1050VAC
 - Working Voltage -----350 VAC

Pin to Pin

- Initial DWV -----Passed
- Thermal DWV-----Passed
- Humidity DWV-----Passed

Row to Row

- Initial DWV -----Passed
- Thermal DWV-----Passed
- Humidity DWV-----Passed

Amphenol VT To Amphenol RA

- **Minimums**
 - Breakdown Voltage----- 1412VAC
 - Test Voltage ----- 1059VAC
 - Working Voltage -----350 VAC

Pin to Pin

- Initial DWV -----Passed
- Thermal DWV-----Passed
- Humidity DWV-----Passed

Row to Row

- Initial DWV -----Passed
- Thermal DWV-----Passed
- Humidity DWV-----Passed

RESULTS Continued

LLCR Gas Tight (32 LLCR test points)

Samtec VT To Samtec RA

- **Initial** -----1.83 mOhms Max
- **Gas-Tight**
 - <= +5.0 mOhms----- 32 Points ----- Stable
 - +5.1 to +10.0 mOhms -----0 Points ----- Minor
 - +10.1 to +15.0 mOhms -----0 Points ----- Acceptable
 - +15.1 to +50.0 mOhms -----0 Points ----- Marginal
 - +50.1 to +1000 mOhms-----0 Points ----- Unstable
 - >+1000 mOhms-----0 Points ----- Open Failure

Samtec VT To Amphenol RA

- **Initial** -----1.78 mOhms Max
- **Gas-Tight**
 - <= +5.0 mOhms----- 32 Points ----- Stable
 - +5.1 to +10.0 mOhms -----0 Points ----- Minor
 - +10.1 to +15.0 mOhms -----0 Points ----- Acceptable
 - +15.1 to +50.0 mOhms -----0 Points ----- Marginal
 - +50.1 to +1000 mOhms-----0 Points ----- Unstable
 - >+1000 mOhms-----0 Points ----- Open Failure

Amphenol VT To Samtec RA

- **Initial** -----1.96 mOhms Max
- **Gas-Tight**
 - <= +5.0 mOhms----- 32 Points ----- Stable
 - +5.1 to +10.0 mOhms -----0 Points ----- Minor
 - +10.1 to +15.0 mOhms -----0 Points ----- Acceptable
 - +15.1 to +50.0 mOhms -----0 Points ----- Marginal
 - +50.1 to +1000 mOhms-----0 Points ----- Unstable
 - >+1000 mOhms-----0 Points ----- Open Failure

Amphenol VT To Amphenol RA

- **Initial** -----1.57 mOhms Max
- **Gas-Tight**
 - <= +5.0 mOhms----- 32 Points ----- Stable
 - +5.1 to +10.0 mOhms -----0 Points ----- Minor
 - +10.1 to +15.0 mOhms -----0 Points ----- Acceptable
 - +15.1 to +50.0 mOhms -----0 Points ----- Marginal
 - +50.1 to +1000 mOhms-----0 Points ----- Unstable
 - >+1000 mOhms-----0 Points ----- Open Failure

DATA SUMMARIES

TEMPERATURE RISE (Current Carrying Capacity, CCC):

- 1) High quality thermocouples whose temperature slopes track one another were used for temperature monitoring.
- 2) The thermocouples were placed at a location to sense the maximum temperature generated during testing.
- 3) Temperature readings recorded are those for which three successive readings, 15 minutes apart, differ less than 1° C (computer controlled data acquisition).
- 4) Adjacent contacts were powered:

Samtec VT To Samtec RA

- a. Linear configuration with 2 adjacent conductors/contacts powered.

CR-959104
2(2X1) Contacts in Series
Part Numbers: HPTS-3-S-D-VT\SUB-HPTT-3-S-6-6-D-RA

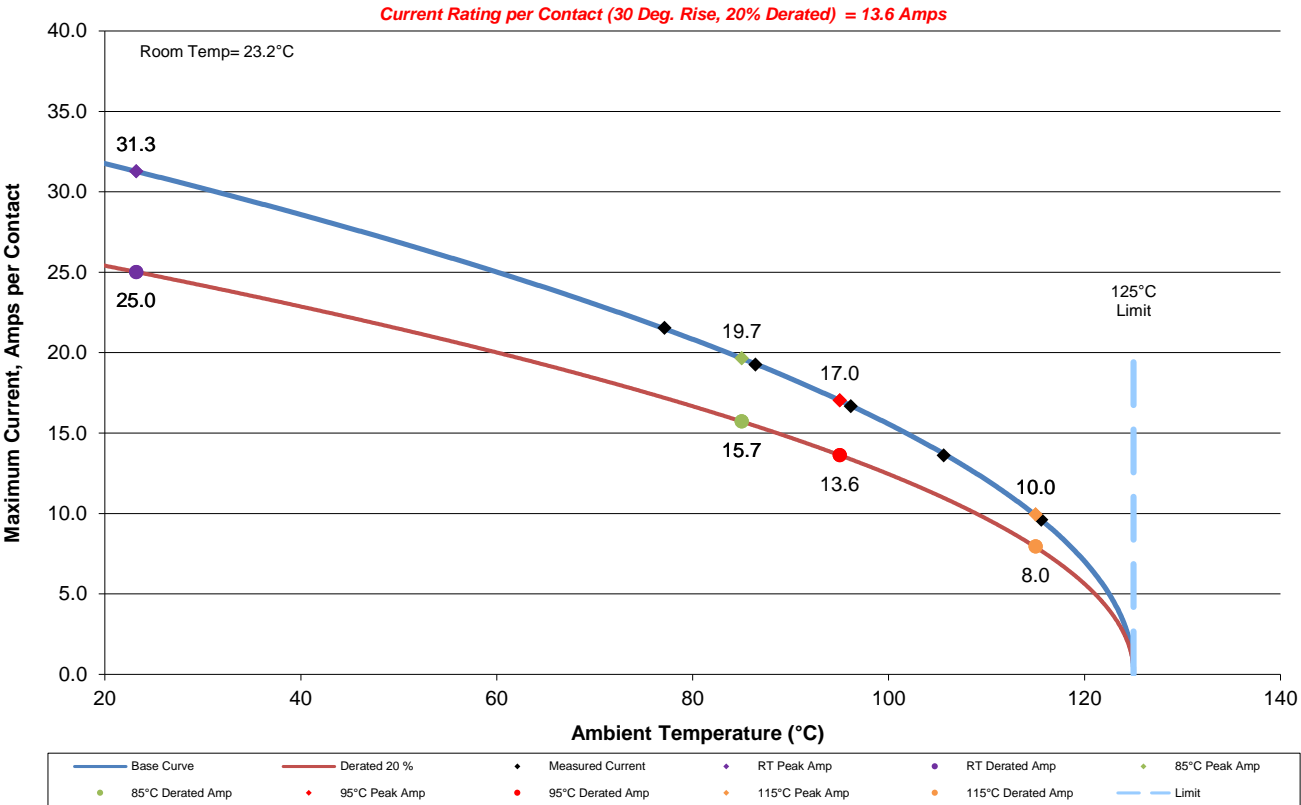

DATA SUMMARIES Continued

CR-959104
2(2X1) Contacts in Series
Part Numbers: HPTS-3-S-D-VT/SUB-HPTT-3-S-6-6-D-RA

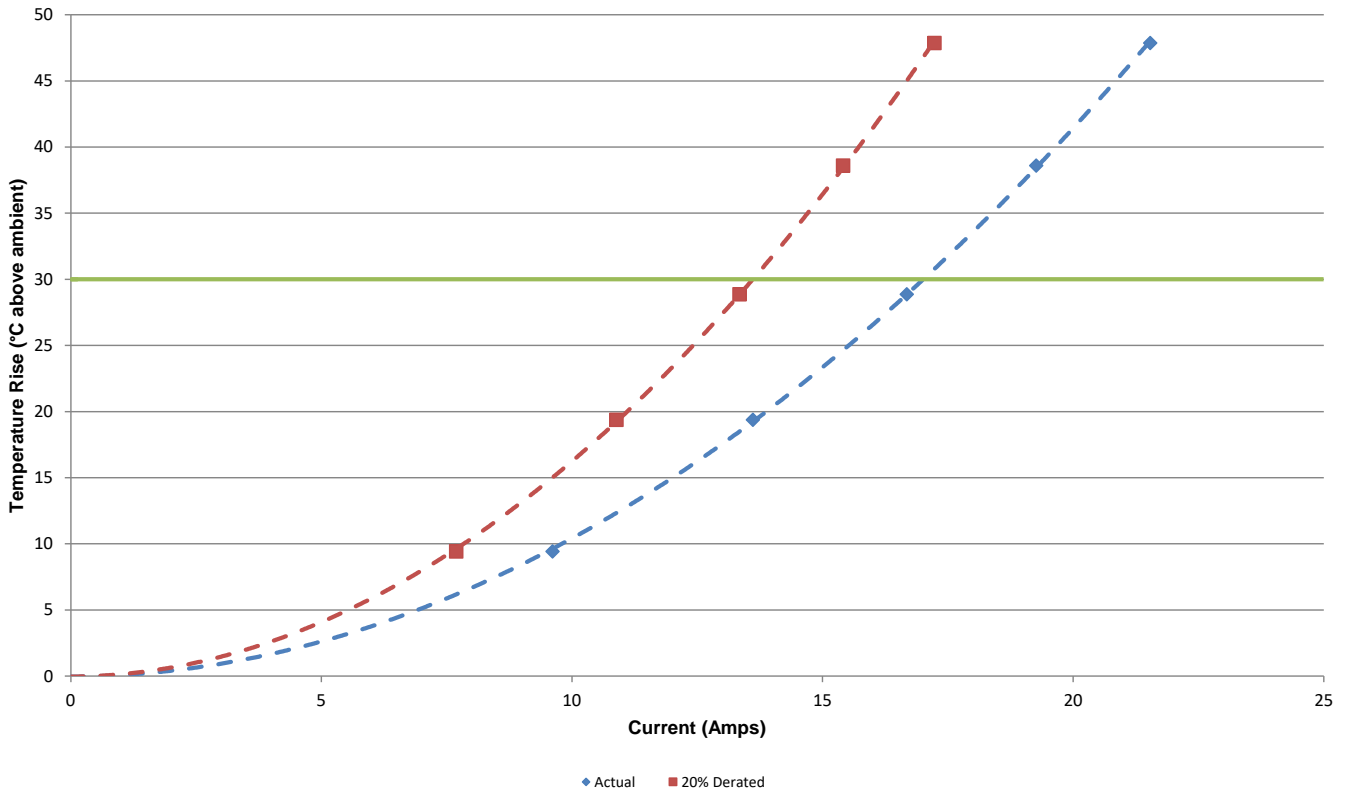

DATA SUMMARIES Continued

b. Linear configuration with 4 adjacent conductors/contacts powered.

CR-959104
 4(2X2) Contacts in Series
 Part Numbers: HPTS-3-S-D-VT/SUB-HPTT-3-S-6-6-D-RA

Current Rating per Contact (30 Deg. Rise, 20% Derated) = 10.8 Amps

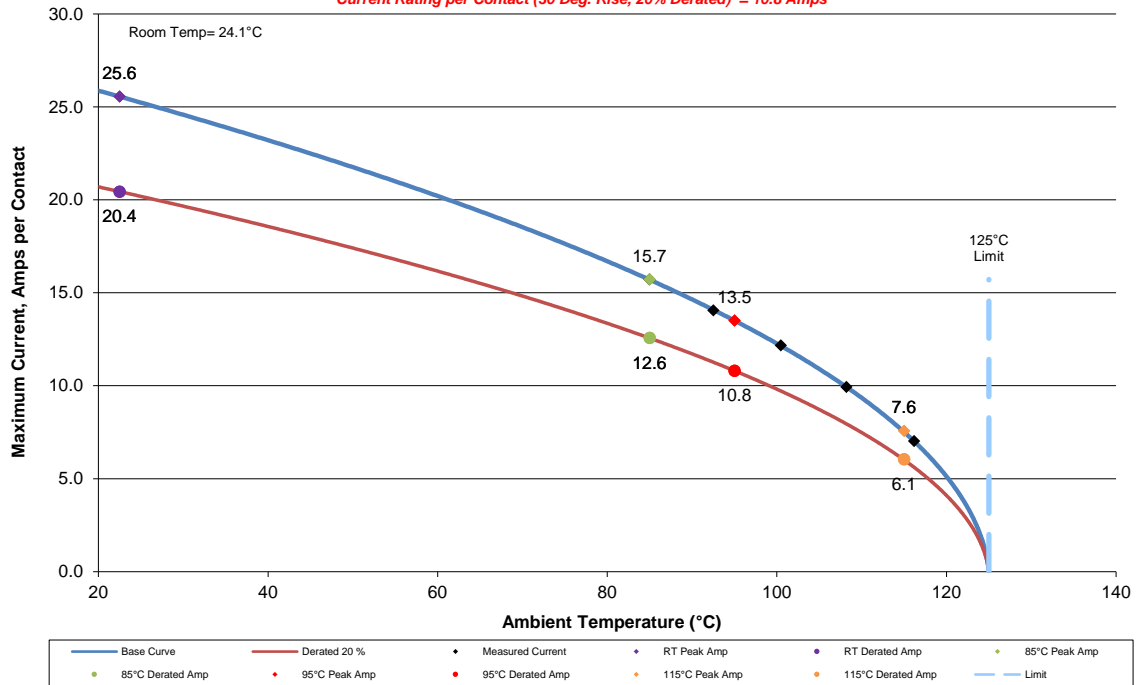

CR-959104
 4(2X2) Contacts in Series
 Part Numbers: HPTS-3-S-D-VT/SUB-HPTT-3-S-6-6-D-RA

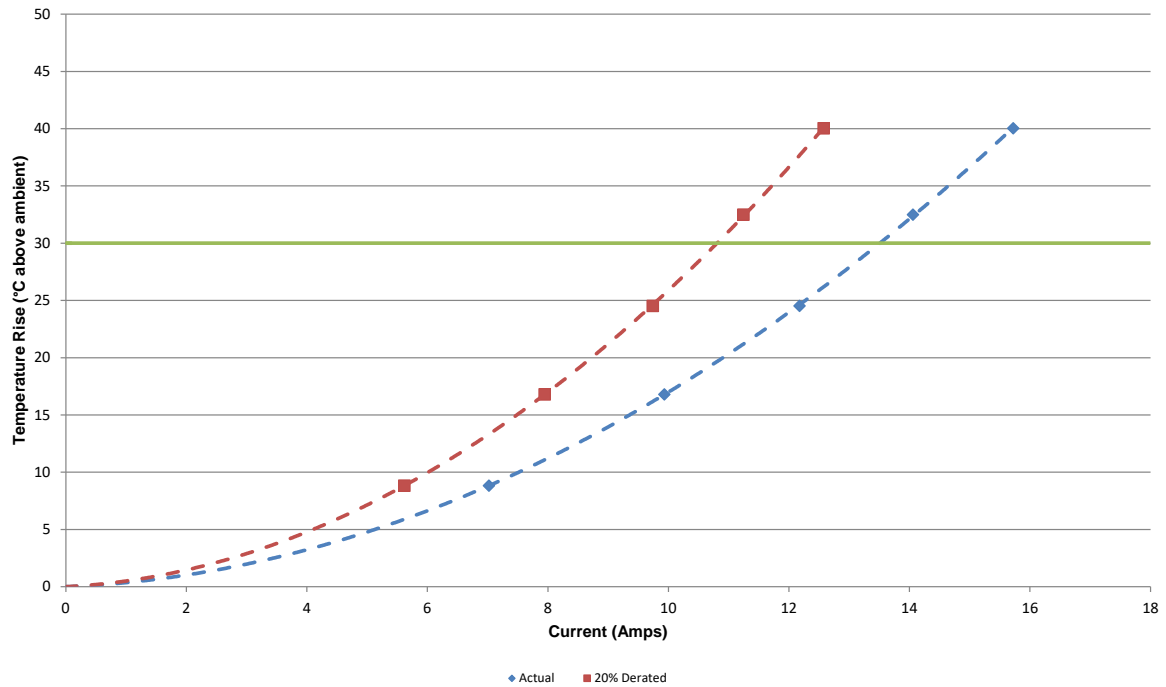

DATA SUMMARIES Continued

Samtec VT To Amphenol RA

a. Linear configuration with 2 adjacent conductors/contacts powered.

CR-959104
 2(2X1) Contacts in Series
 Part Numbers: HPTS-3-S-D-VT\928-3000-D8H
 Current Rating per Contact (30 Deg. Rise, 20% Derated) = 13.5 Amps

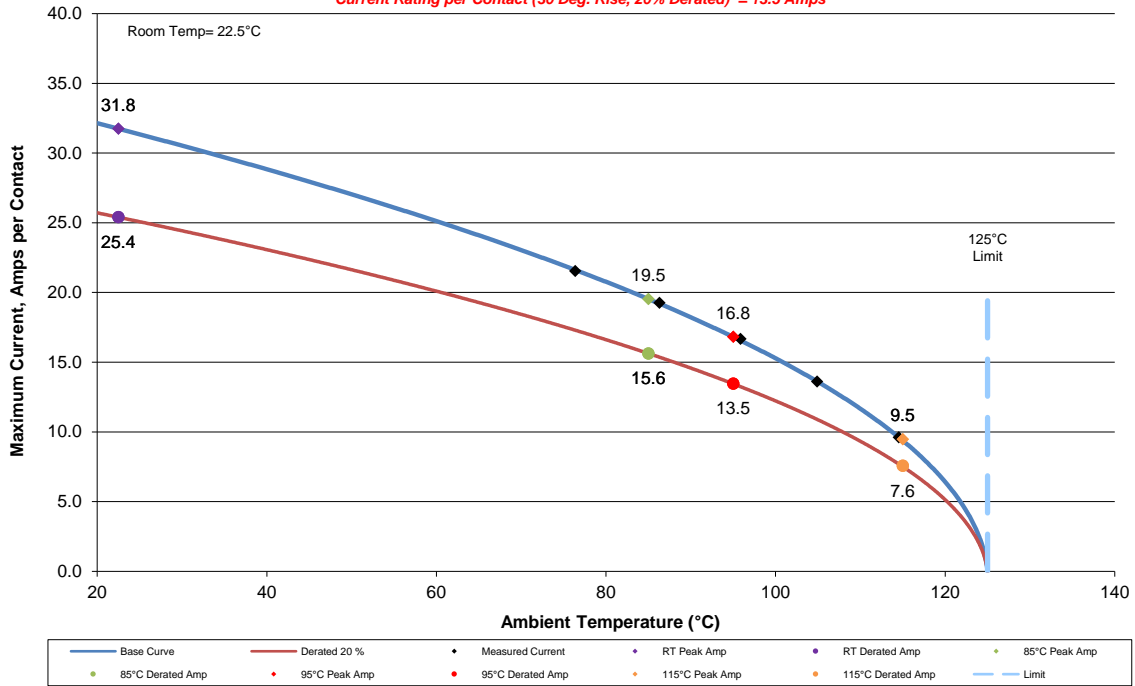

CR-959104
 2(2X1) Contacts in Series
 Part Numbers: HPTS-3-S-D-VT\928-3000-D8H

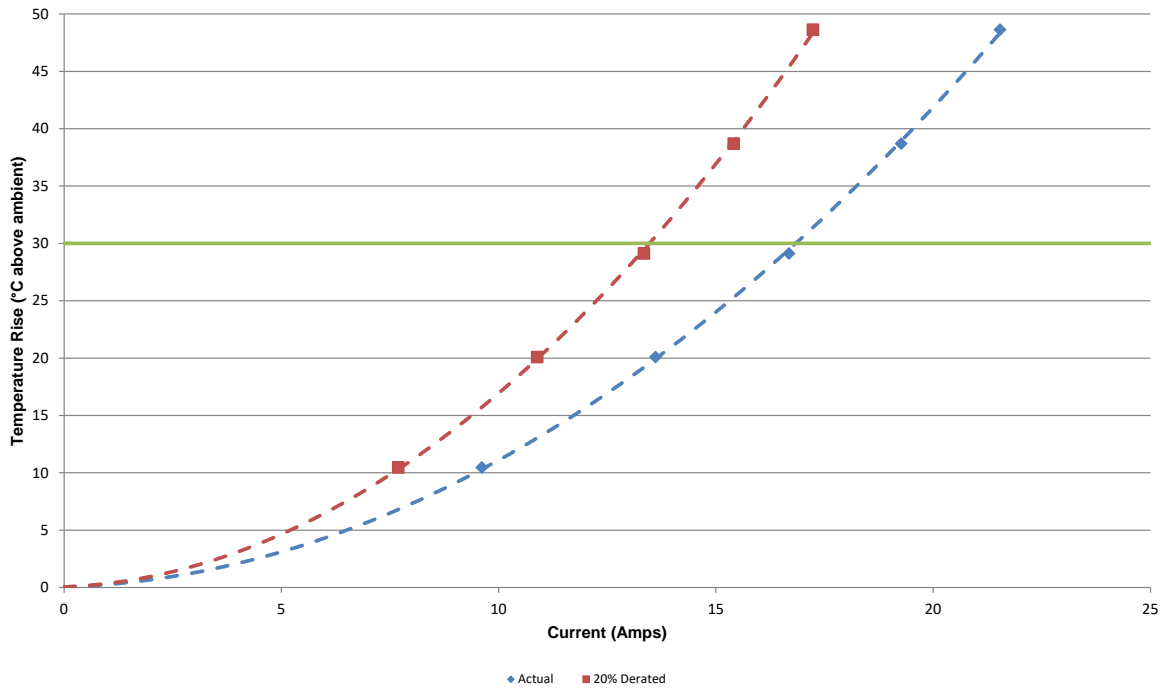

DATA SUMMARIES Continued

b. Linear configuration with 4 adjacent conductors/contacts powered.

CR-959104
4(2X2) Contacts in Series
Part Numbers: HPTS-3-S-D-VT/928-3000-D8H

Current Rating per Contact (30 Deg. Rise, 20% Derated) = 11.4 Amps

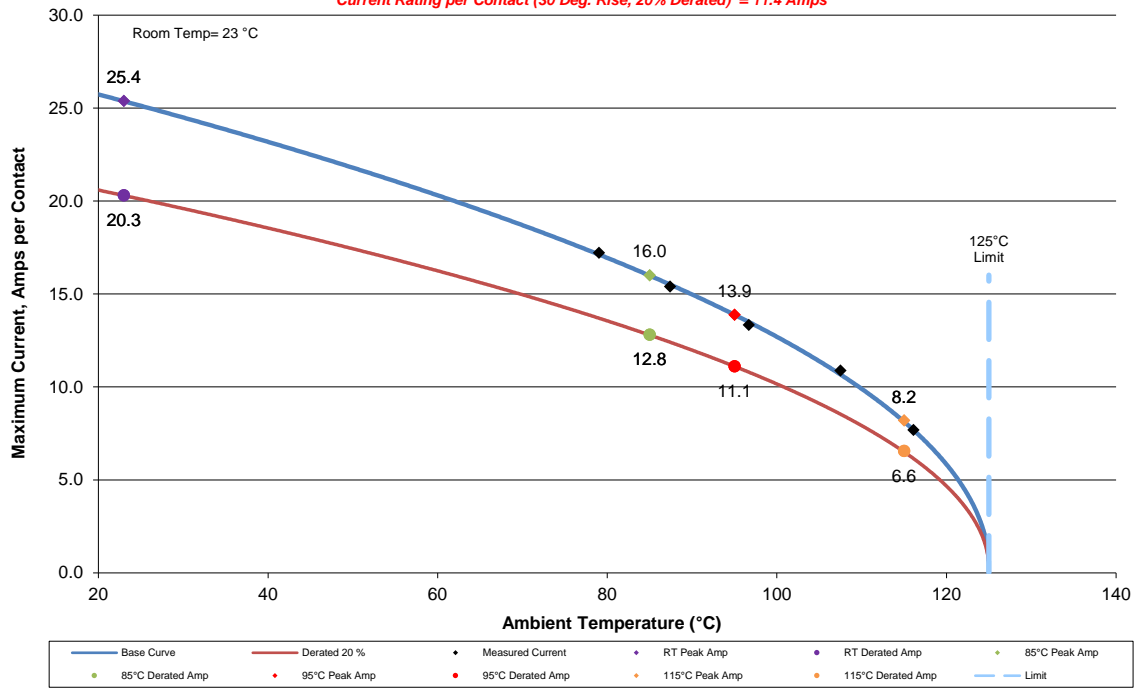

CR-959104
4(2X2) Contacts in Series
Part Numbers: HPTS-3-S-D-VT/928-3000-D8H

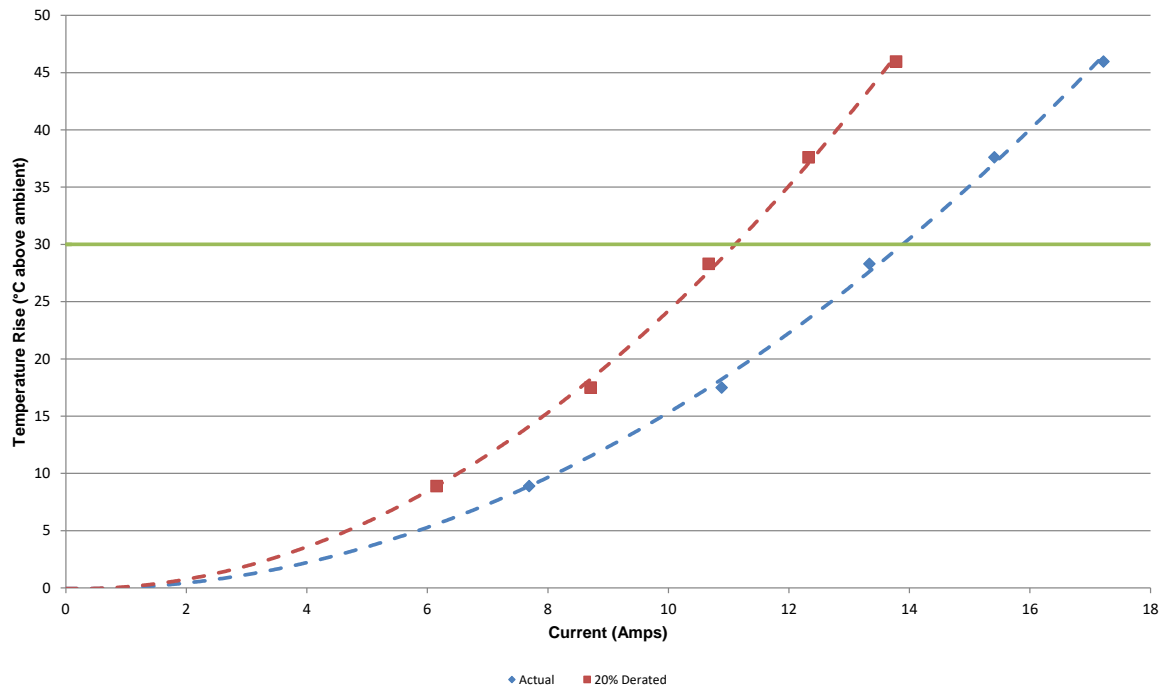

DATA SUMMARIES Continued

Amphenol VT To Samtec RA

a. Linear configuration with 2 adjacent conductors/contacts powered.

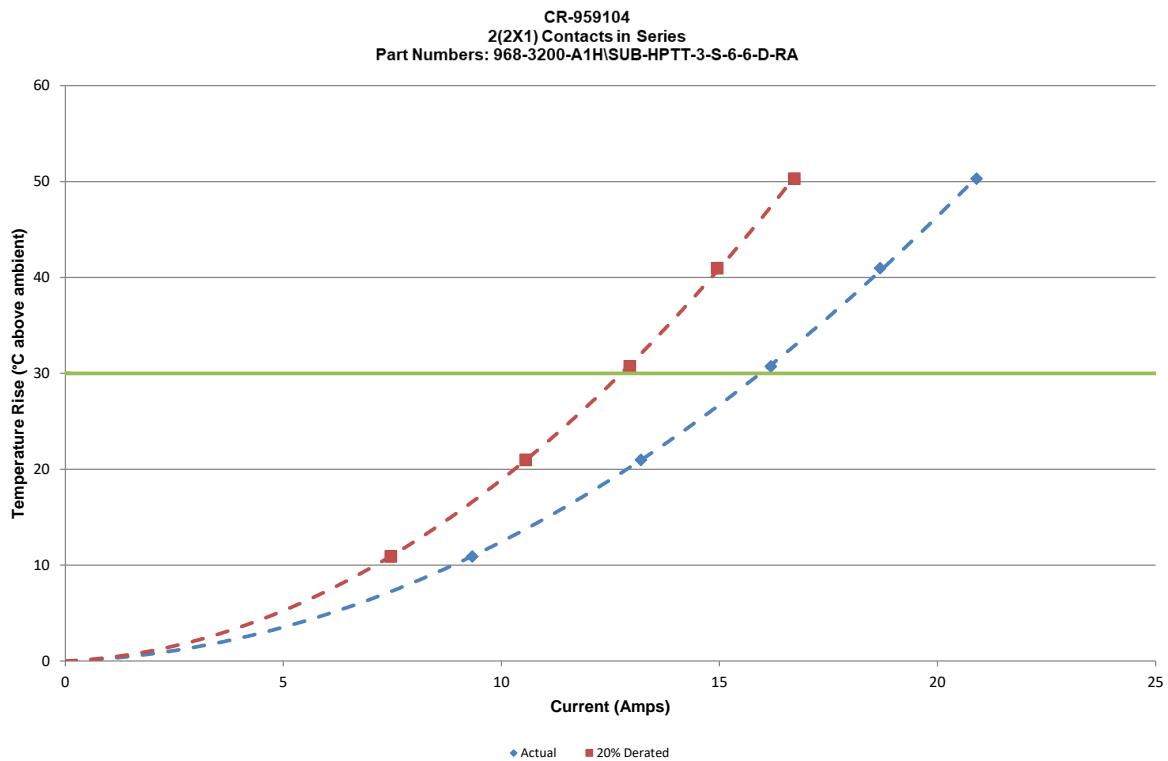
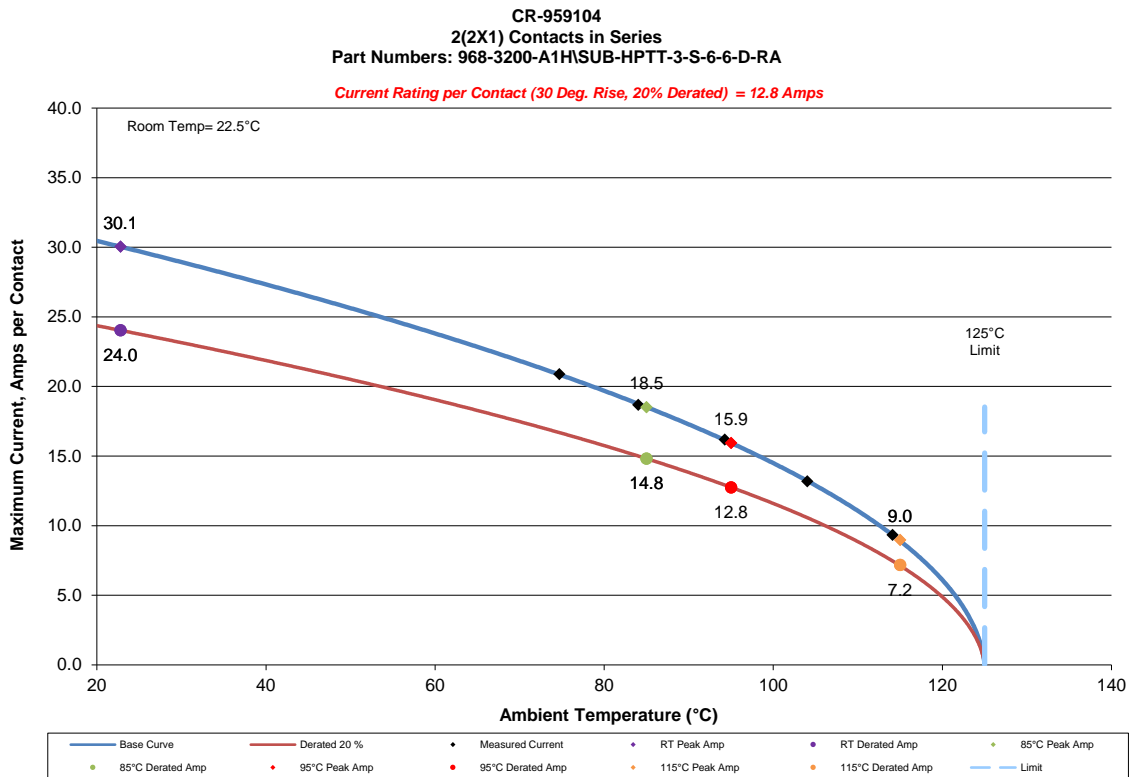

DATA SUMMARIES Continued

b. Linear configuration with 4 adjacent conductors/contacts powered.

CR-959104
4(2X2) Contacts in Series
Part Numbers: 968-3200-A1H/SUB-HPTT-3-S-6-6-D-RA

Current Rating per Contact (30 Deg. Rise, 20% Derated) = 10.6 Amps

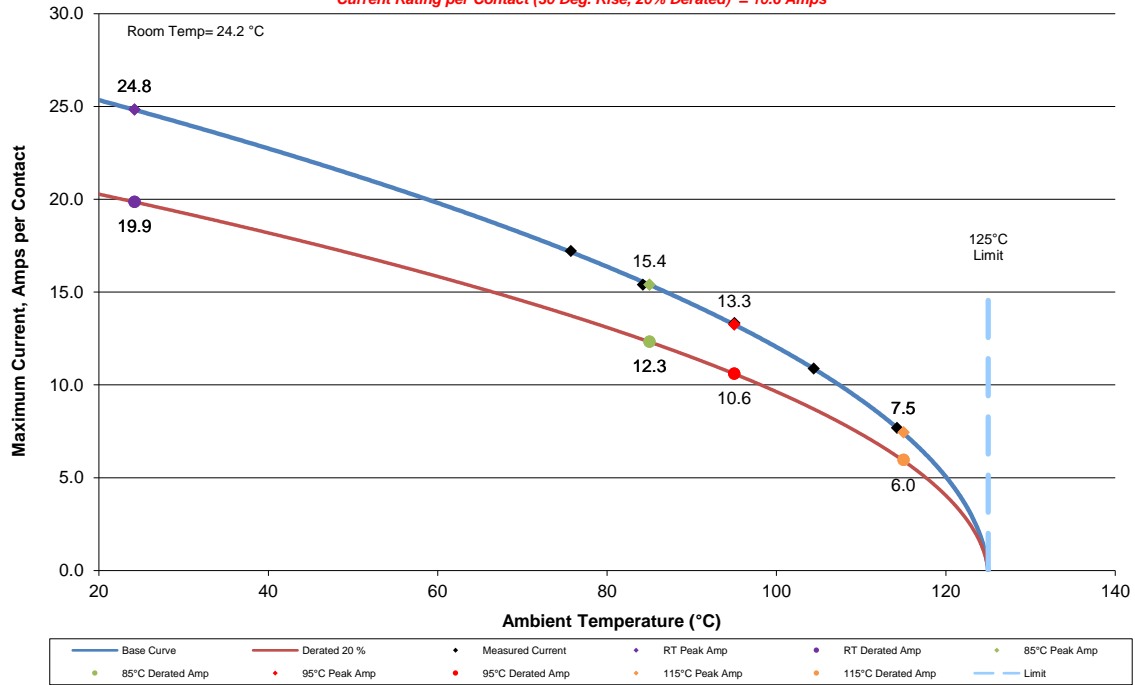

CR-959104
4(2X2) Contacts in Series
Part Numbers: 968-3200-A1H/SUB-HPTT-3-S-6-6-D-RA

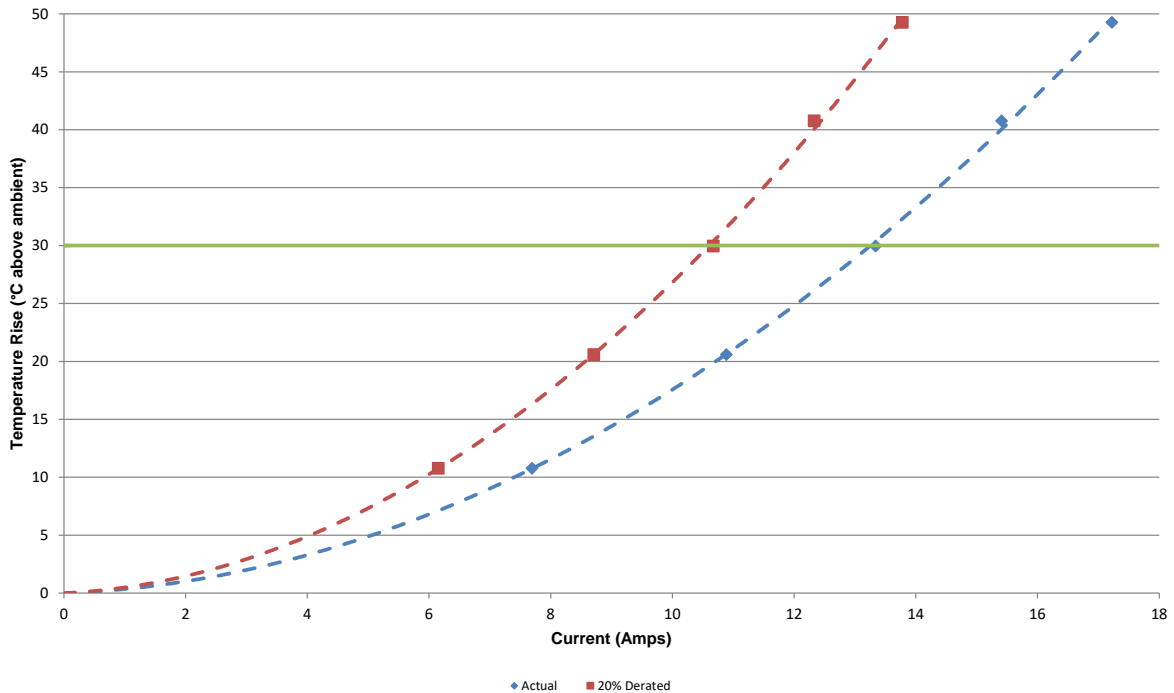

DATA SUMMARIES Continued

Amphenol VT To Amphenol RA

a. Linear configuration with 2 adjacent conductors/contacts powered.

CR-1017104
2(2X1) Contacts in Series
Part Numbers: 968-3200-A1H928-3000-D8H

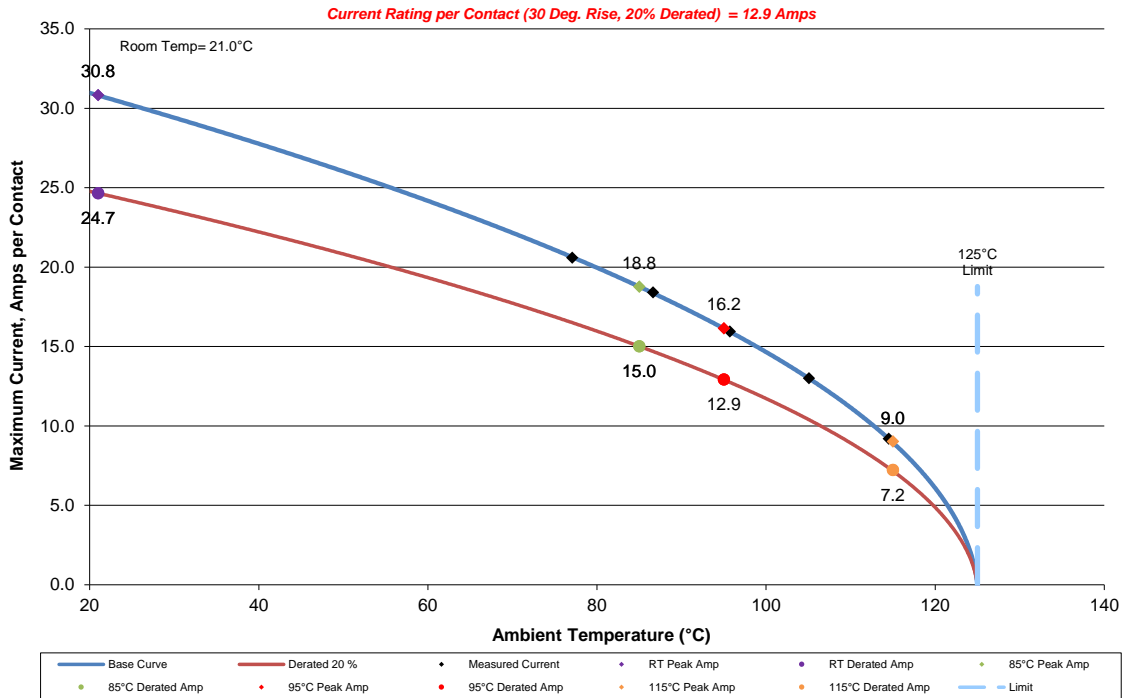

CR-1017104
2(2X1) Contacts in Series
Part Numbers: 968-3200-A1H928-3000-D8H

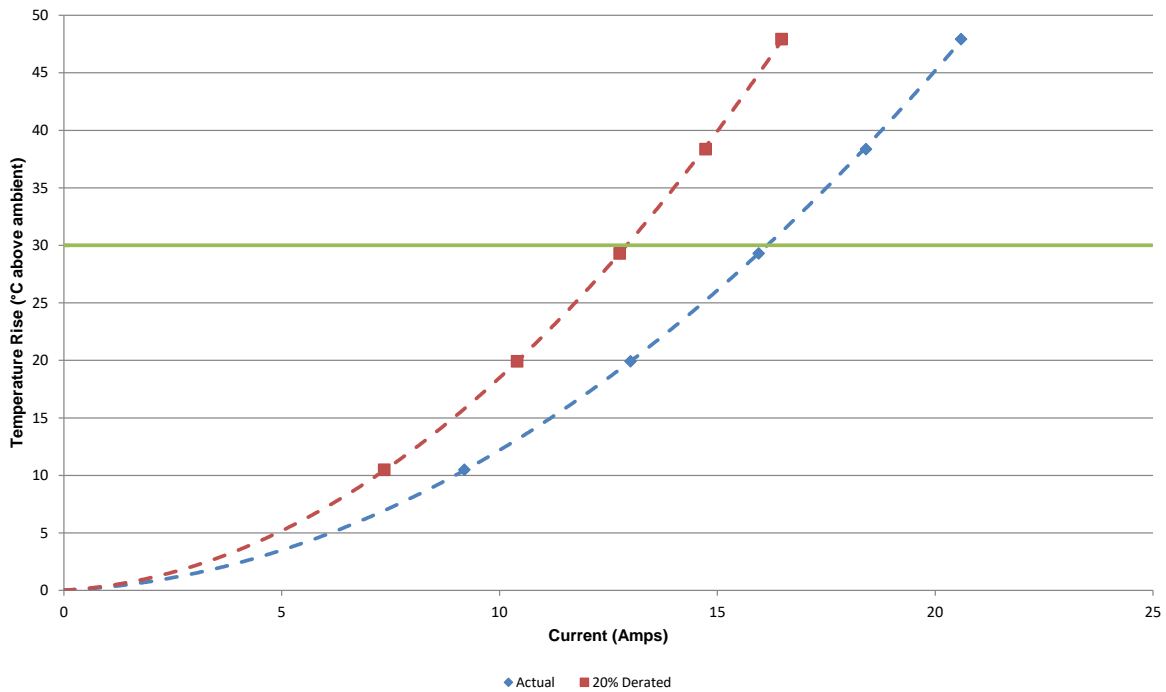

DATA SUMMARIES Continued

b. Linear configuration with 4 adjacent conductors/contacts powered.

CR-1017104
 4(2X2) Contacts in Series
 Part Numbers: 968-3200-A1H928-3000-D8H

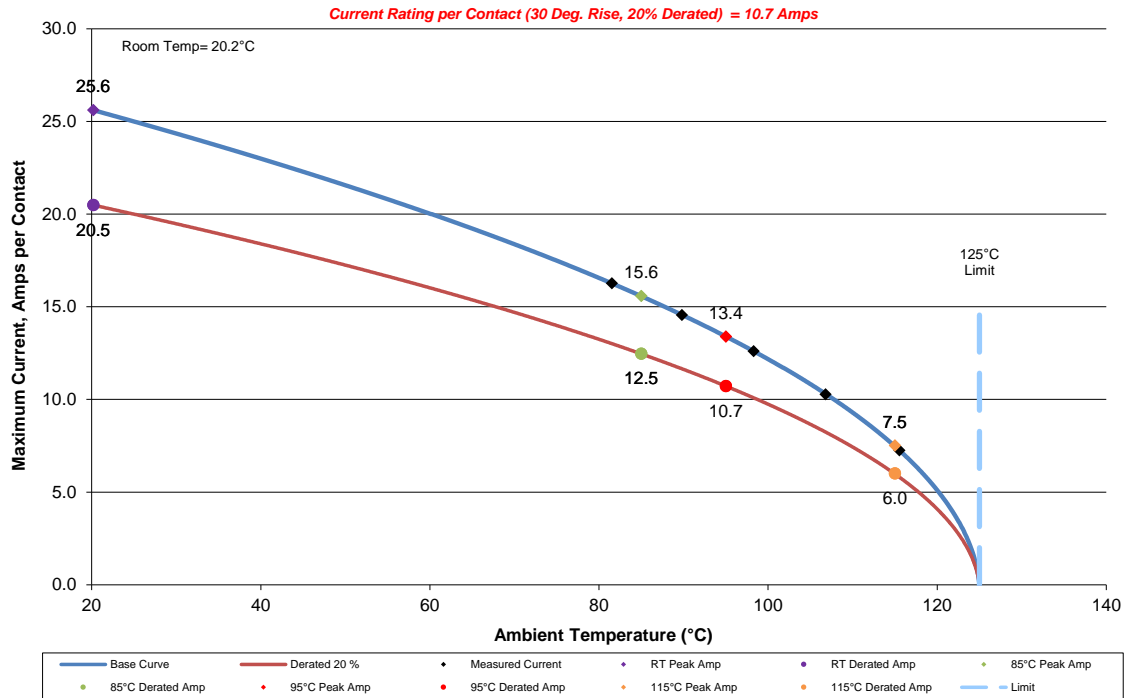

CR-1017104
 4(2X2) Contacts in Series
 Part Numbers: 968-3200-A1H928-3000-D8H

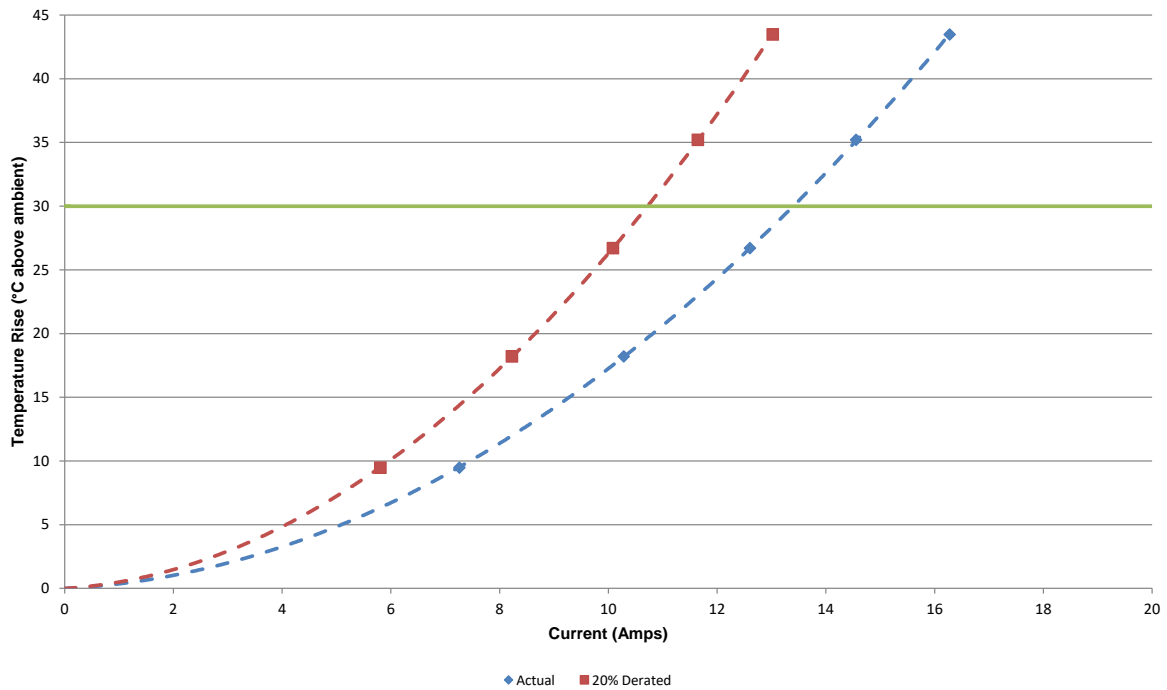

DATA SUMMARIES Continued

NORMAL FORCE (FOR CONTACTS TESTED OUTSIDE THE HOUSING):

- 1) Calibrated force gauges are used along with computer-controlled positioning equipment.
- 2) Typically, 8-10 readings are taken and the averages reported.

Samtec VT To Samtec RA

Long Pin

Initial	Deflections in inches Forces in Grams										
	0.0010	0.0020	0.0030	0.0040	0.0050	0.0060	0.0070	0.0080	0.0090	0.0100	SET
Averages	3.38	7.16	10.59	13.82	17.59	20.92	23.77	27.78	31.10	34.31	0.0001
Min	3.00	6.50	10.10	13.10	16.60	19.90	22.50	26.50	30.00	32.90	0.0000
Max	3.70	7.40	11.00	14.50	18.30	21.80	24.60	29.00	32.80	35.90	0.0002
St. Dev	0.229	0.281	0.332	0.422	0.444	0.527	0.588	0.678	0.782	0.885	0.0001
Count	12	12	12	12	12	12	12	12	12	12	12

After Thermals	Deflections in inches Forces in Grams										
	0.0010	0.0020	0.0030	0.0040	0.0050	0.0060	0.0070	0.0080	0.0090	0.0100	SET
Averages	0.08	3.64	7.13	10.32	13.70	17.11	20.13	23.48	27.18	30.28	0.0010
Min	-0.70	2.40	6.30	9.20	12.10	15.60	18.30	21.50	24.90	27.90	0.0007
Max	0.80	4.50	7.80	11.30	15.10	18.20	21.20	24.70	28.40	31.80	0.0014
St. Dev	0.386	0.675	0.571	0.638	0.819	0.710	0.785	0.849	0.923	0.989	0.0002
Count	12	12	12	12	12	12	12	12	12	12	12

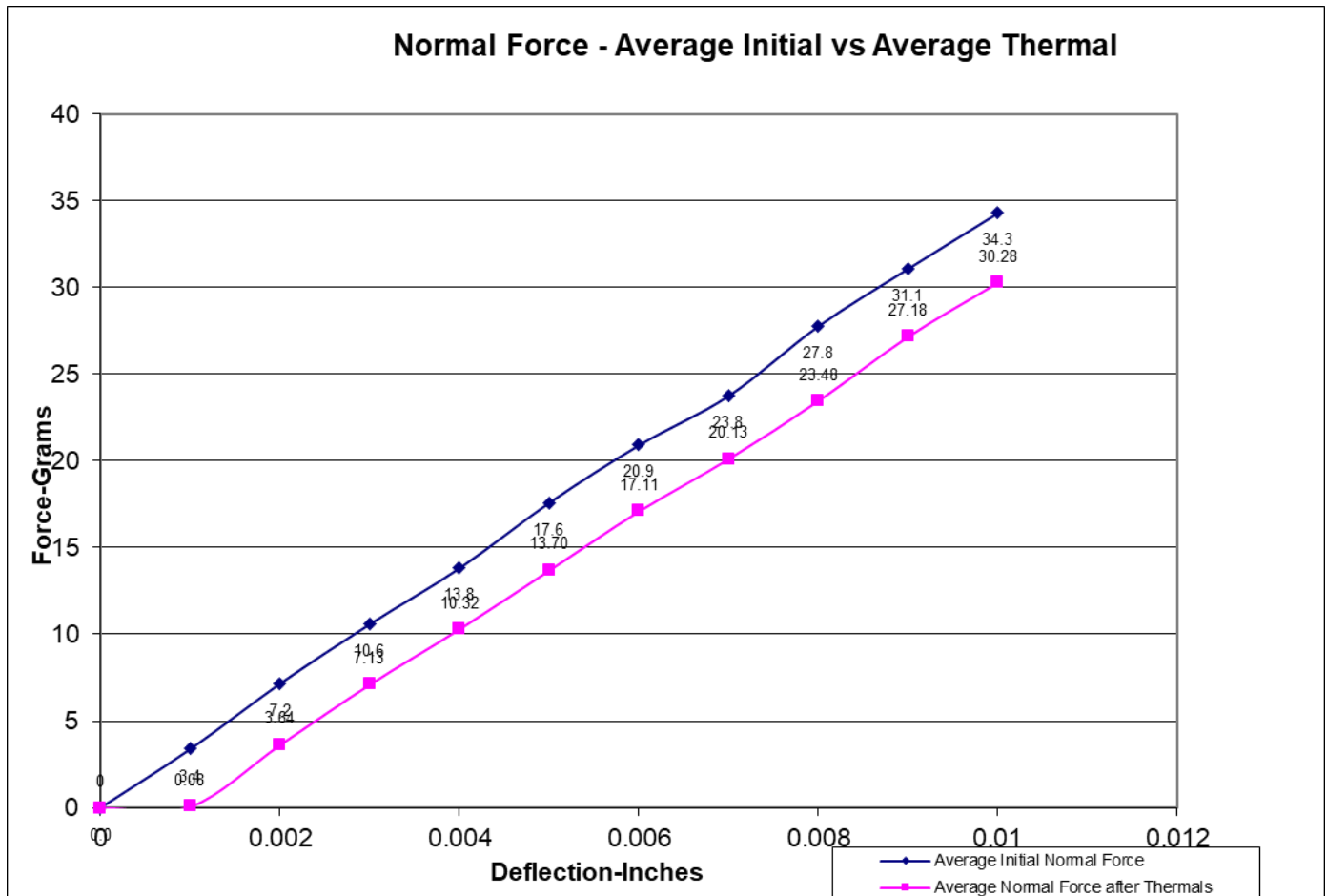

DATA SUMMARIES Continued

Short Pin

Initial	Deflections in inches Forces in Grams										
	<u>0.0010</u>	<u>0.0020</u>	<u>0.0030</u>	<u>0.0040</u>	<u>0.0050</u>	<u>0.0060</u>	<u>0.0070</u>	<u>0.0080</u>	<u>0.0090</u>	<u>0.0100</u>	<i>SET</i>
Averages	5.19	11.32	16.93	22.94	28.47	34.15	38.70	44.53	49.81	54.93	0.0002
Min	3.20	9.00	14.40	20.20	25.00	30.20	35.00	40.20	45.10	49.80	0.0000
Max	6.00	12.00	18.10	24.30	30.70	36.80	41.90	48.80	54.60	60.30	0.0007
St. Dev	0.722	0.844	1.053	1.193	1.464	1.653	1.748	2.165	2.362	2.636	0.0002
Count	12	12	12	12	12	12	12	12	12	12	12

After Thermals	Deflections in inches Forces in Grams										
	<u>0.0010</u>	<u>0.0020</u>	<u>0.0030</u>	<u>0.0040</u>	<u>0.0050</u>	<u>0.0060</u>	<u>0.0070</u>	<u>0.0080</u>	<u>0.0090</u>	<u>0.0100</u>	<i>SET</i>
Averages	0.70	6.13	11.75	17.06	22.78	28.00	33.06	38.54	43.92	48.74	0.0010
Min	-0.30	2.20	8.50	13.40	19.70	25.00	30.70	35.90	40.10	45.40	0.0004
Max	7.30	13.70	19.70	26.00	30.90	35.20	38.80	43.70	48.30	52.40	0.0015
St. Dev	2.097	2.630	2.682	3.042	2.708	2.490	2.100	2.080	2.159	1.974	0.0003
Count	12	12	12	12	12	12	12	12	12	12	12

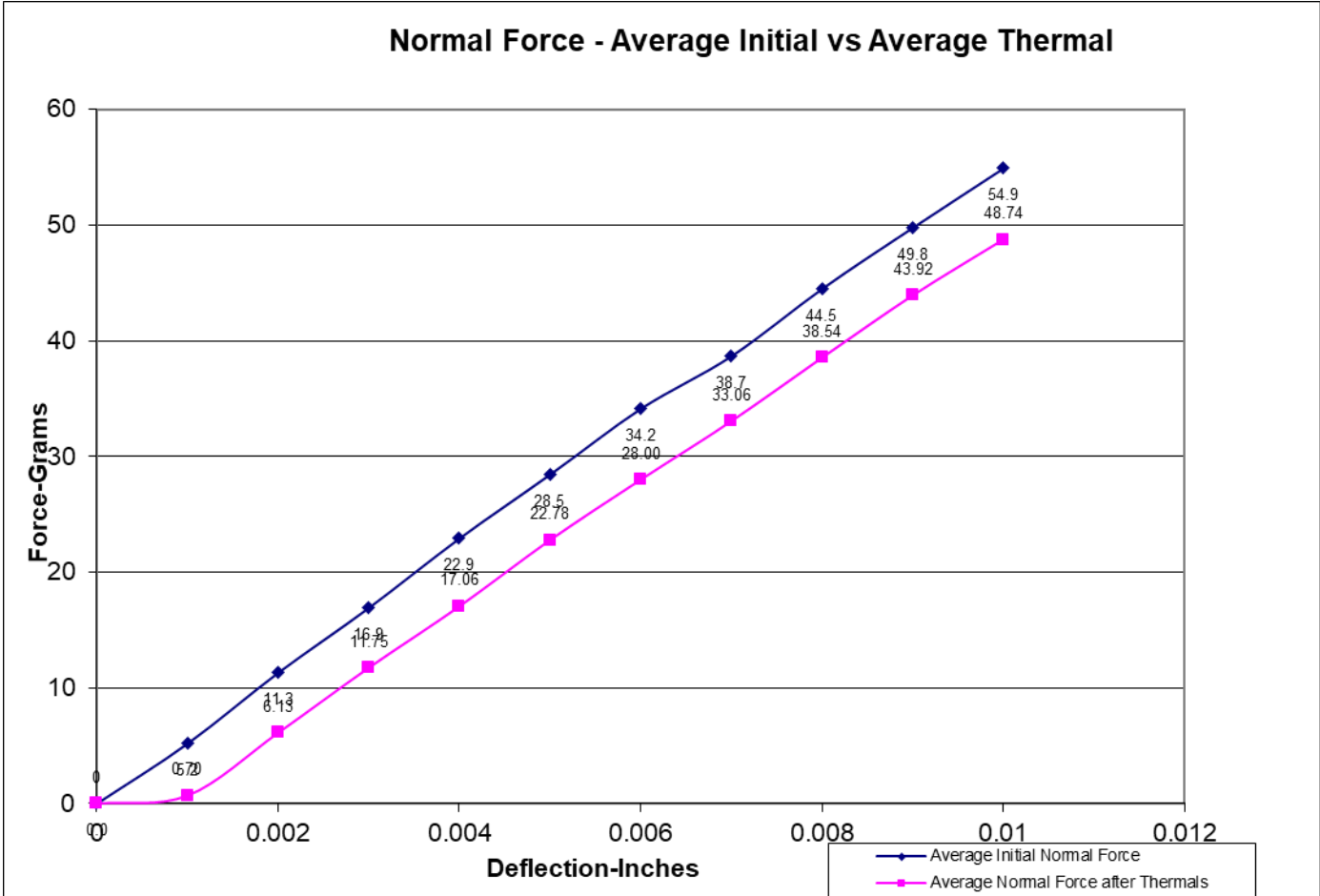

DATA SUMMARIES Continued

Samtec VT To Amphenol RA

Long Pin

Initial	Deflections in inches Forces in Grams										
	<u>0.0010</u>	<u>0.0020</u>	<u>0.0030</u>	<u>0.0040</u>	<u>0.0050</u>	<u>0.0060</u>	<u>0.0070</u>	<u>0.0080</u>	<u>0.0090</u>	<u>0.0100</u>	<i>SET</i>
Averages	4.01	8.41	12.33	16.35	20.65	24.54	28.26	32.76	36.62	40.98	0.0001
Min	3.50	7.50	10.90	15.00	19.10	22.70	26.60	31.00	34.60	38.40	0.0000
Max	4.90	9.50	13.40	18.20	21.90	26.00	30.40	34.30	38.30	42.70	0.0002
St. Dev	0.489	0.608	0.729	0.927	0.847	0.994	1.148	1.012	1.158	1.307	0.0001
Count	12	12	12	12	12	12	12	12	12	12	12

After Thermals	Deflections in inches Forces in Grams										
	<u>0.0010</u>	<u>0.0020</u>	<u>0.0030</u>	<u>0.0040</u>	<u>0.0050</u>	<u>0.0060</u>	<u>0.0070</u>	<u>0.0080</u>	<u>0.0090</u>	<u>0.0100</u>	<i>SET</i>
Averages	0.54	4.41	7.90	11.32	15.18	18.80	21.83	25.49	29.04	32.38	0.0010
Min	-0.10	3.60	6.90	10.50	13.70	17.40	20.40	23.60	27.30	30.40	0.0002
Max	2.20	6.20	9.70	13.40	17.60	22.10	25.30	28.20	31.80	35.20	0.0015
St. Dev	0.695	0.780	0.827	0.908	1.111	1.320	1.400	1.360	1.259	1.339	0.0003
Count	12	12	12	12	12	12	12	12	12	12	12

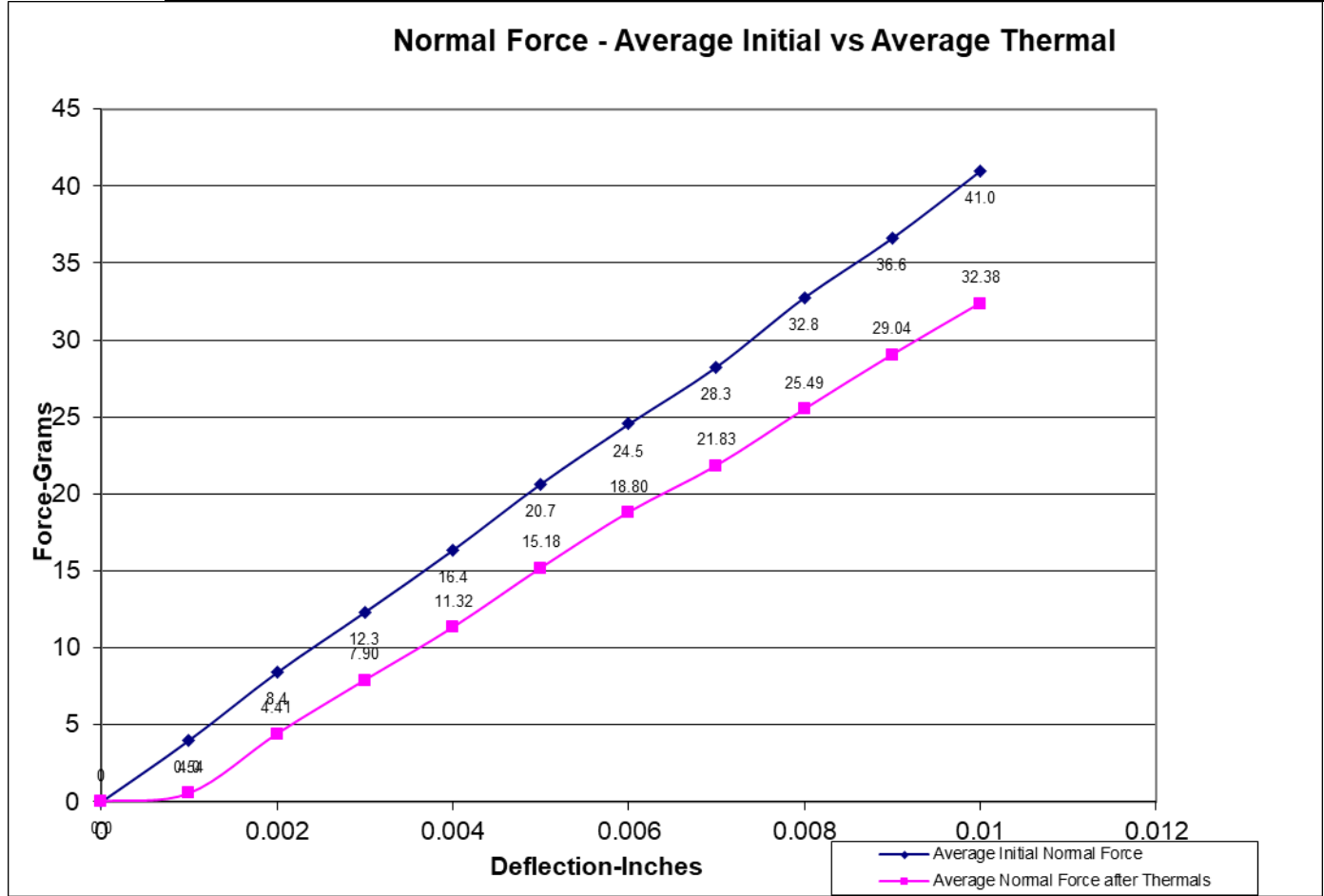

DATA SUMMARIES Continued

Short Pin

Initial	Deflections in inches Forces in Grams										
	0.0010	0.0020	0.0030	0.0040	0.0050	0.0060	0.0070	0.0080	0.0090	0.0100	SET
Averages	7.40	14.18	20.96	27.86	34.62	41.31	47.08	54.47	60.86	67.28	0.0002
Min	5.90	13.10	18.70	24.70	30.40	36.00	40.40	46.00	51.50	56.00	0.0000
Max	8.30	15.50	22.90	29.50	37.40	44.40	51.10	58.20	66.00	72.00	0.0016
St. Dev	0.729	0.747	1.351	1.455	2.164	2.357	2.969	3.369	3.833	4.328	0.0005
Count	12	12	12	12	12	12	12	12	12	12	12

After Thermals	Deflections in inches Forces in Grams										
	0.0010	0.0020	0.0030	0.0040	0.0050	0.0060	0.0070	0.0080	0.0090	0.0100	SET
Averages	0.26	6.39	11.83	17.63	23.23	28.81	34.11	40.18	46.08	51.77	0.0011
Min	-0.60	4.70	9.60	14.70	20.40	25.10	30.00	34.80	38.70	43.60	0.0008
Max	2.10	8.90	14.50	21.20	26.90	33.30	38.50	45.30	51.60	57.40	0.0019
St. Dev	0.717	1.139	1.385	2.093	2.156	2.740	2.875	3.236	3.726	3.845	0.0003
Count	12	12	12	12	12	12	12	12	12	12	12

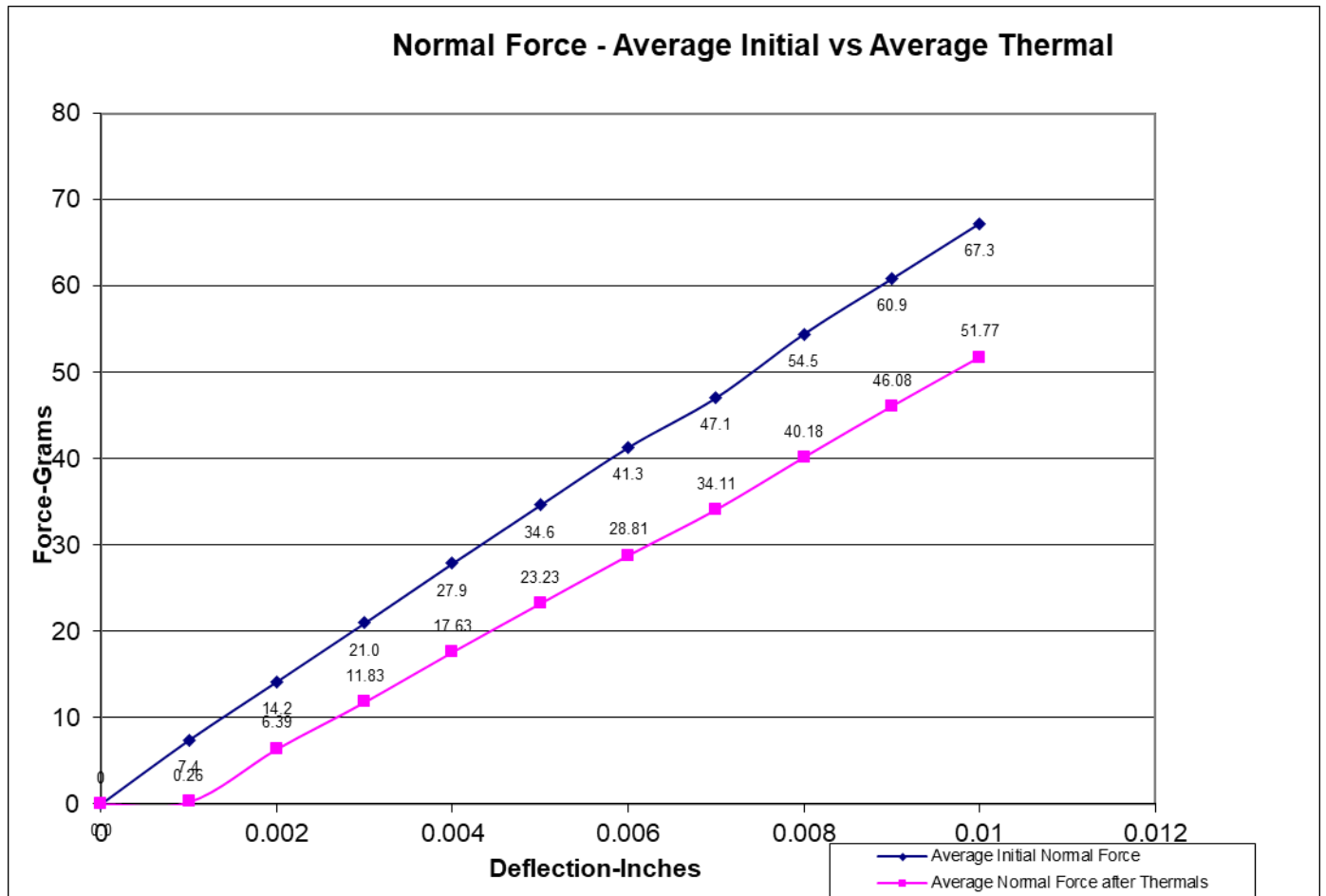

DATA SUMMARIES Continued

Amphenol VT To Samtec RA

Long Pin

Initial	Deflections in inches Forces in Grams										
	0.0010	0.0020	0.0030	0.0040	0.0050	0.0060	0.0070	0.0080	0.0090	0.0100	SET
Averages	4.21	7.89	11.16	14.68	18.30	21.51	24.48	28.53	31.72	34.93	0.0001
Min	2.60	6.00	9.00	12.10	15.60	19.00	21.80	26.00	29.20	32.20	0.0000
Max	7.30	11.00	15.10	19.10	22.20	25.50	28.40	31.80	34.90	38.20	0.0003
St. Dev	1.532	1.653	1.840	2.030	1.957	1.964	2.085	1.904	1.917	1.861	0.0001
Count	12	12	12	12	12	12	12	12	12	12	12

After Thermals	Deflections in inches Forces in Grams										
	0.0010	0.0020	0.0030	0.0040	0.0050	0.0060	0.0070	0.0080	0.0090	0.0100	SET
Averages	0.45	3.98	7.28	10.42	13.61	17.14	19.96	23.32	26.86	29.91	0.0009
Min	-0.10	3.10	6.40	9.40	12.30	15.80	18.60	21.80	25.00	28.10	0.0007
Max	1.40	4.80	8.40	11.60	15.40	18.60	21.60	25.40	28.70	32.10	0.0011
St. Dev	0.495	0.557	0.649	0.674	0.933	0.830	0.901	0.993	1.106	1.151	0.0001
Count	12	12	12	12	12	12	12	12	12	12	12

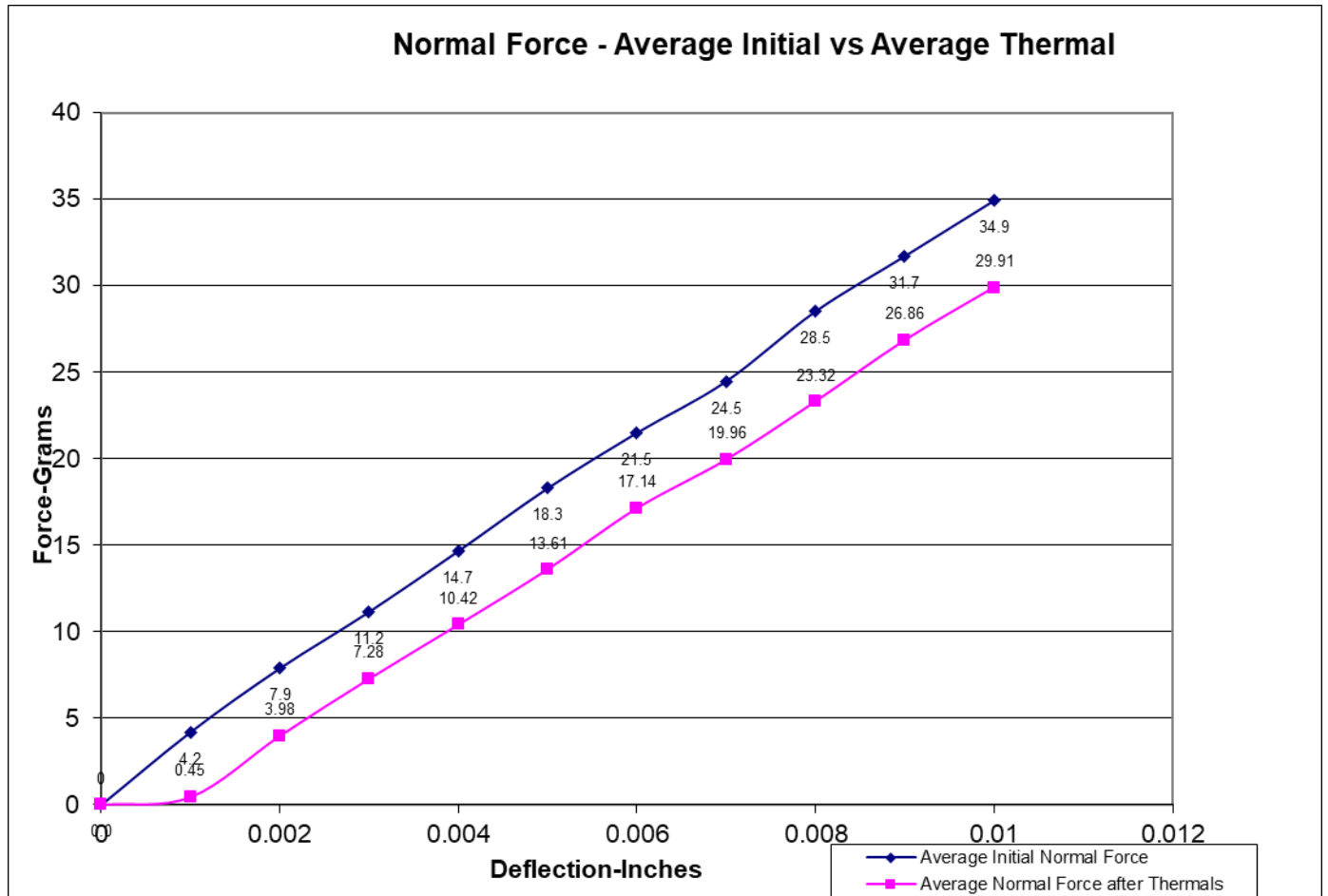

DATA SUMMARIES Continued

Short Pin

Initial	Deflections in inches Forces in Grams										
	0.0010	0.0020	0.0030	0.0040	0.0050	0.0060	0.0070	0.0080	0.0090	0.0100	SET
Averages	5.28	10.81	16.09	21.83	27.17	33.00	37.62	43.33	48.68	53.46	0.0004
Min	0.00	0.10	2.90	8.70	14.70	20.60	25.60	32.60	38.40	44.00	0.0000
Max	10.30	15.90	21.60	27.40	32.90	38.70	43.20	49.20	54.60	59.30	0.0028
St. Dev	2.239	3.683	4.473	4.467	4.318	4.382	4.327	4.108	4.167	4.011	0.0008
Count	12	12	12	12	12	12	12	12	12	12	12

After Thermals	Deflections in inches Forces in Grams										
	0.0010	0.0020	0.0030	0.0040	0.0050	0.0060	0.0070	0.0080	0.0090	0.0100	SET
Averages	0.68	6.49	11.57	16.88	22.25	27.43	32.23	37.50	42.66	47.64	0.0009
Min	-0.10	5.20	10.20	15.60	20.70	25.70	30.50	35.50	40.40	45.30	0.0001
Max	4.10	11.10	16.60	22.20	27.10	32.30	36.00	41.30	46.20	50.90	0.0014
St. Dev	1.136	1.554	1.680	1.885	1.744	1.848	1.670	1.754	1.883	1.728	0.0003
Count	12	12	12	12	12	12	12	12	12	12	12

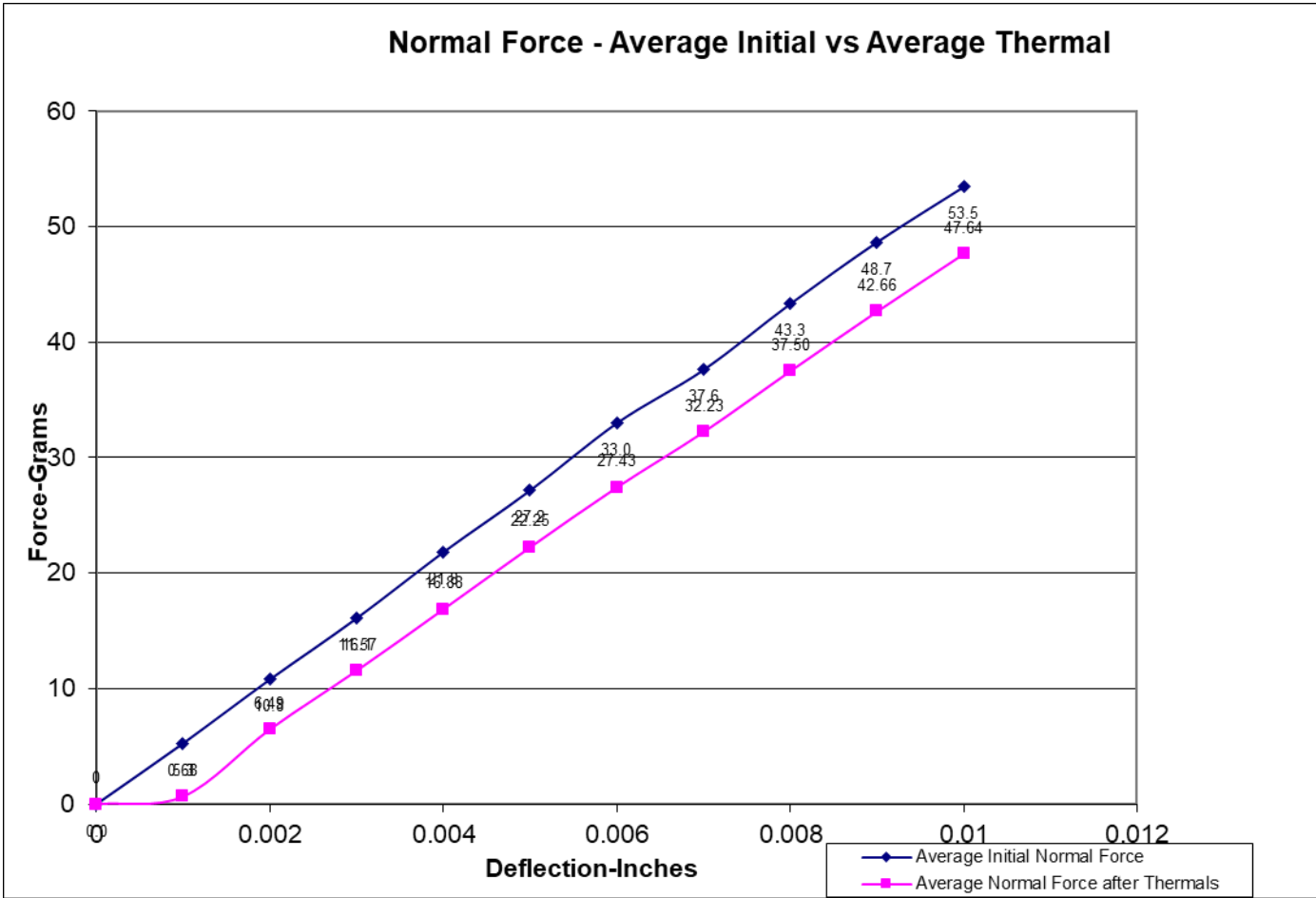

DATA SUMMARIES Continued

Amphenol VT To Amphenol RA
Long Pin

Initial	Deflections in inches Forces in Grams										
	0.0010	0.0020	0.0030	0.0040	0.0050	0.0060	0.0070	0.0080	0.0090	0.0100	SET
Averages	4.21	7.89	11.16	14.68	18.30	21.51	24.48	28.53	31.72	34.93	0.0001
Min	2.60	6.00	9.00	12.10	15.60	19.00	21.80	26.00	29.20	32.20	0.0000
Max	7.30	11.00	15.10	19.10	22.20	25.50	28.40	31.80	34.90	38.20	0.0003
St. Dev	1.532	1.653	1.840	2.030	1.957	1.964	2.085	1.904	1.917	1.861	0.0001
Count	12	12	12	12	12	12	12	12	12	12	12

After Thermals	Deflections in inches Forces in Grams										
	0.0010	0.0020	0.0030	0.0040	0.0050	0.0060	0.0070	0.0080	0.0090	0.0100	SET
Averages	0.45	3.98	7.28	10.42	13.61	17.14	19.96	23.32	26.86	29.91	0.0009
Min	-0.10	3.10	6.40	9.40	12.30	15.80	18.60	21.80	25.00	28.10	0.0007
Max	1.40	4.80	8.40	11.60	15.40	18.60	21.60	25.40	28.70	32.10	0.0011
St. Dev	0.495	0.557	0.649	0.674	0.933	0.830	0.901	0.993	1.106	1.151	0.0001
Count	12	12	12	12	12	12	12	12	12	12	12

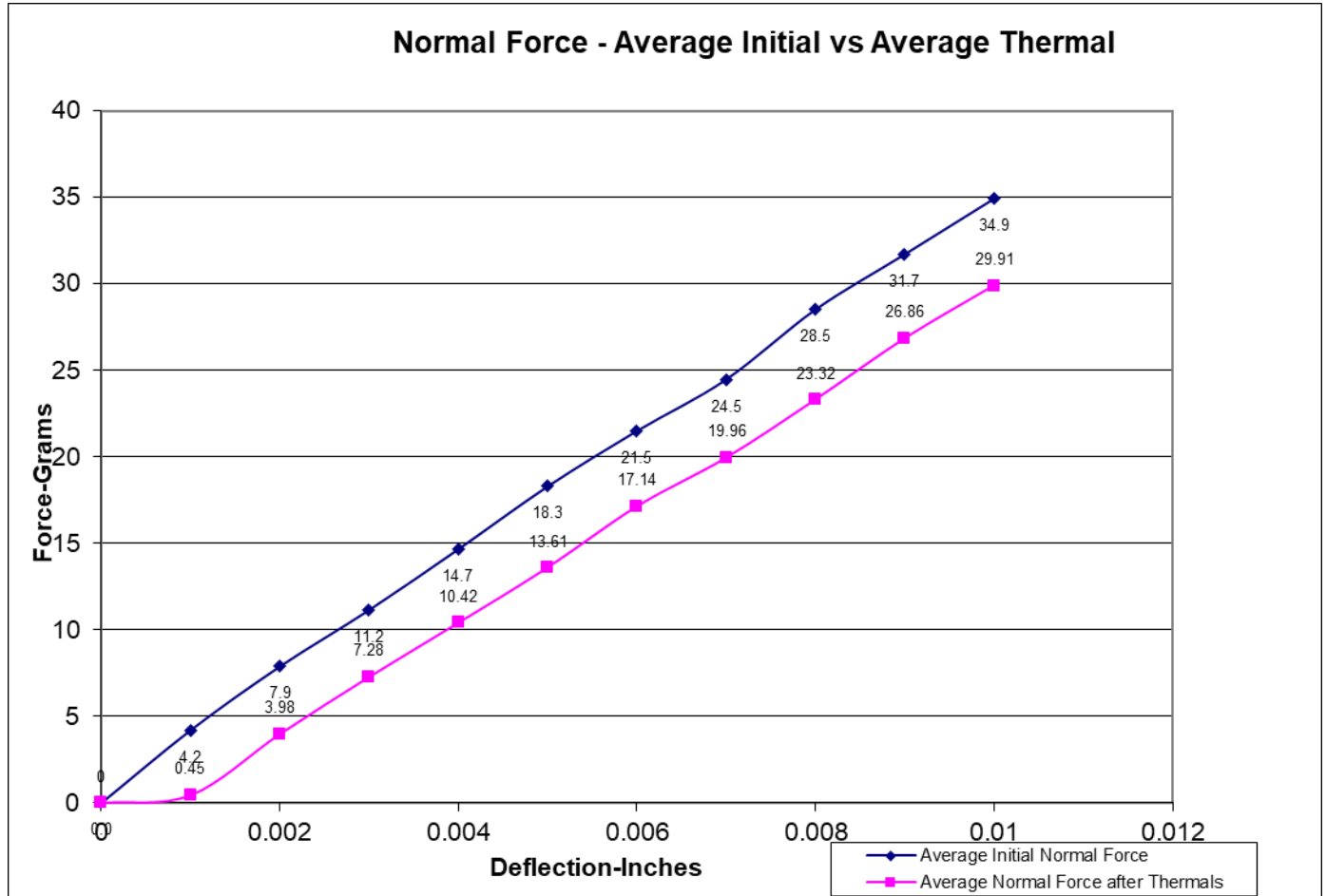

DATA SUMMARIES Continued

Short Pin

Initial	Deflections in inches Forces in Grams										
	0.0010	0.0020	0.0030	0.0040	0.0050	0.0060	0.0070	0.0080	0.0090	0.0100	SET
Averages	5.28	10.81	16.09	21.83	27.17	33.00	37.62	43.33	48.68	53.46	0.0004
Min	0.00	0.10	2.90	8.70	14.70	20.60	25.60	32.60	38.40	44.00	0.0000
Max	10.30	15.90	21.60	27.40	32.90	38.70	43.20	49.20	54.60	59.30	0.0028
St. Dev	2.239	3.683	4.473	4.467	4.318	4.382	4.327	4.108	4.167	4.011	0.0008
Count	12	12	12	12	12	12	12	12	12	12	12

After Thermals	Deflections in inches Forces in Grams										
	0.0010	0.0020	0.0030	0.0040	0.0050	0.0060	0.0070	0.0080	0.0090	0.0100	SET
Averages	0.68	6.49	11.57	16.88	22.25	27.43	32.23	37.50	42.66	47.64	0.0009
Min	-0.10	5.20	10.20	15.60	20.70	25.70	30.50	35.50	40.40	45.30	0.0001
Max	4.10	11.10	16.60	22.20	27.10	32.30	36.00	41.30	46.20	50.90	0.0014
St. Dev	1.136	1.554	1.680	1.885	1.744	1.848	1.670	1.754	1.883	1.728	0.0003
Count	12	12	12	12	12	12	12	12	12	12	12

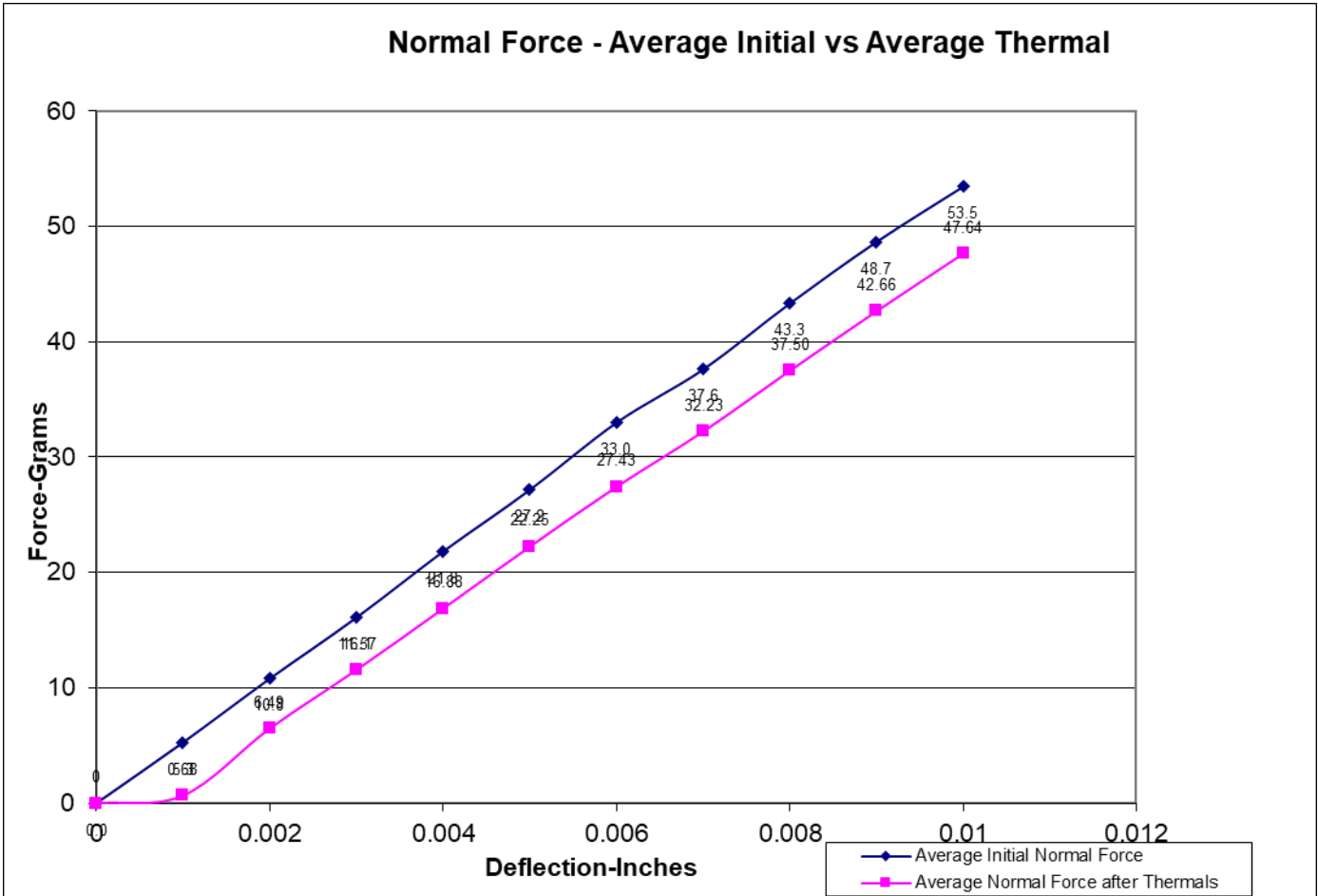

DATA SUMMARIES Continued**INSULATION RESISTANCE (IR):**

Samtec VT To Samtec RA

	Pin to Pin		
	Mated	Unmated	Unmated
Minimum	HPTS\SUB-HPTT	HPTS	SUB-HPTT
Initial	45000	45000	45000
Thermal	45000	45000	45000
Humidity	45000	45000	45000

	Row to Row		
	Mated	Unmated	Unmated
Minimum	HPTS\SUB-HPTT	HPTS	SUB-HPTT
Initial	45000	45000	45000
Thermal	45000	45000	45000
Humidity	45000	45000	45000

Samtec VT To Amphenol RA

	Pin to Pin		
	Mated	Unmated	Unmated
Minimum	HPTS/928-3000	HPTS	928-3000
Initial	45000	45000	45000
Thermal	45000	45000	45000
Humidity	45000	45000	45000

	Row to Row		
	Mated	Unmated	Unmated
Minimum	HPTS/928-3000	HPTS	928-3000
Initial	45000	45000	45000
Thermal	45000	45000	45000
Humidity	45000	45000	45000

Amphenol VT To Samtec RA

	Pin to Pin		
	Mated	Unmated	Unmated
Minimum	968-3200/SUB-HPTT	968-3200	SUB-HPTT
Initial	45000	45000	45000
Thermal	45000	45000	45000
Humidity	45000	45000	45000

	Row to Row		
	Mated	Unmated	Unmated
Minimum	968-3200/SUB-HPTT	968-3200	SUB-HPTT
Initial	45000	45000	45000
Thermal	45000	45000	45000
Humidity	45000	45000	45000

DATA SUMMARIES Continued

Amphenol VT To Amphenol RA

	Pin to Pin		
	Mated	Unmated	Unmated
Minimum	968-3200/928-3000	968-3200	928-3000
Initial	45000	45000	45000
Thermal	45000	45000	45000
Humidity	45000	45000	45000

	Row to Row		
	Mated	Unmated	Unmated
Minimum	968-3200/928-3000	968-3200	928-3000
Initial	45000	45000	45000
Thermal	45000	45000	45000
Humidity	45000	45000	45000

DIELECTRIC WITHSTANDING VOLTAGE (DWV):

Samtec VT To Samtec RA

Voltage Rating Summary	
Minimum	HPTS/SUB-HPTT
Break Down Voltage	2555
Test Voltage	1920
Working Voltage	635

Pin to Pin	
Initial Test Voltage	Passed
After Thermal Test Voltage	Passed
After Humidity Test Voltage	Passed

Row to Row	
Initial Test Voltage	Passed
After Thermal Test Voltage	Passed
After Humidity Test Voltage	Passed

Samtec VT To Amphenol RA

Voltage Rating Summary	
Minimum	HPTS/928-3000
Break Down Voltage	1529
Test Voltage	1150
Working Voltage	380

Pin to Pin	
Initial Test Voltage	Passed
After Thermal Test Voltage	Passed
After Humidity Test Voltage	Passed

Row to Row	
Initial Test Voltage	Passed
After Thermal Test Voltage	Passed
After Humidity Test Voltage	Passed

DATA SUMMARIES Continued

Amphenol VT To Samtec RA

Voltage Rating Summary	
Minimum	968-3200/SUB-HPTT
Break Down Voltage	1399
Test Voltage	1050
Working Voltage	350

Pin to Pin	
Initial Test Voltage	Pass
After Thermal Test Voltage	pass
After Humidity Test Voltage	pass

Row to Row	
Initial Test Voltage	Passed
After Thermal Test Voltage	Passed
After Humidity Test Voltage	Passed

Amphenol VT To Amphenol RA

Voltage Rating Summary	
Minimum	968-3200/928-3000
Break Down Voltage	1412
Test Voltage	1059
Working Voltage	350

Pin to Pin	
Initial Test Voltage	Passed
After Thermal Test Voltage	Passed
After Humidity Test Voltage	Passed

Row to Row	
Initial Test Voltage	Passed
After Thermal Test Voltage	Passed
After Humidity Test Voltage	Passed

DATA SUMMARIES Continued

LLCR Gas Tight:

- 1) A total of 32 points were measured.
- 2) EIA-364-23, *Low Level Contact Resistance Test Procedure for Electrical Connectors and Sockets*.
- 3) A computer program, *LLCR 221.exe*, ensures repeatability for data acquisition.
- 4) The following guidelines are used to categorize the changes in LLCR as a result from stressing.
 - a. $\leq +5.0$ mOhms: -----Stable
 - b. $+5.1$ to $+10.0$ mOhms: -----Minor
 - c. $+10.1$ to $+15.0$ mOhms: -----Acceptable
 - d. $+15.1$ to $+50.0$ mOhms: -----Marginal
 - e. $+50.1$ to $+1000$ mOhms: -----Unstable
 - f. $>+1000$ mOhms: -----Open Failure

Samtec VT To Samtec RA

LLCR Measurement Summaries by Pin Type			
Date	7/25/2023	7/27/2023	
Room Temp (Deg C)	23	23	
Rel Humidity (%)	54	54	
Technician	Peter Chen	Peter Chen	
mOhm values	Actual	Delta	
	Initial	Acid Vapor	
Pin Type: Signal 1			
Average	1.46	0.14	
St. Dev.	0.13	0.12	
Min	1.29	0	
Max	1.83	0.38	
Summary Count	32	32	
Total Count	32	32	

LLCR Delta Count by Category						
	Stable	Minor	Acceptable	Marginal	Unstable	Open
mOhms	≤ 1	$>1 \ \& \ \leq 2$	$>2 \ \& \ \leq 5$	$>5 \ \& \ \leq 15$	$>15 \ \& \ \leq 1000$	>1000
Acid Vapor	32	0	0	0	0	0

DATA SUMMARIES Continued

Samtec VT To Amphenol RA

LLCR Measurement Summaries by Pin Type			
	Date	7/25/2023	7/28/2023
Room Temp (Deg C)		23	23
Rel Humidity (%)		54	54
Technician		Peter Chen	Peter Chen
mOhm values		Actual	Delta
		Initial	Acid Vapor
Pin Type: Signal 1			
Average		1.53	0.24
St. Dev.		0.1	0.16
Min		1.29	0
Max		1.78	0.57
Summary Count		32	32
Total Count		32	32

LLCR Delta Count by Category						
	Stable	Minor	Acceptable	Marginal	Unstable	Open
mOhms	<=1	>1 & <=2	>2 & <=5	>5 & <=15	>15 & <=1000	>1000
Acid Vapor	32	0	0	0	0	0

Amphenol VT To Samtec RA

LLCR Measurement Summaries by Pin Type			
	Date	7/25/2023	7/27/2023
Room Temp (Deg C)		23	23
Rel Humidity (%)		54	54
Technician		Peter Chen	Peter Chen
mOhm values		Actual	Delta
		Initial	Acid Vapor
Pin Type: Signal 1			
Average		1.49	0.13
St. Dev.		0.16	0.13
Min		1.28	0
Max		1.96	0.48
Summary Count		32	32
Total Count		32	32

LLCR Delta Count by Category						
	Stable	Minor	Acceptable	Marginal	Unstable	Open
mOhms	<=1	>1 & <=2	>2 & <=5	>5 & <=15	>15 & <=1000	>1000
Acid Vapor	32	0	0	0	0	0

DATA SUMMARIES Continued

Amphenol VT To Amphenol RA

LLCR Measurement Summaries by Pin Type					
	Date	2023/11/21	2023/11/22		
	Room Temp (Deg C)	22	22		
	Rel Humidity (%)	52	52		
	Technician	Kason He	Kason He		
	mOhm values	Actual	Delta		
		Initial	Acid Vapor		
Pin Type: Signal 1					
	Average	1.39	0.17		
	St. Dev.	0.07	0.09		
	Min	1.26	0.02		
	Max	1.57	0.38		
	Summary Count	32	32		
	Total Count	32	32		

LLCR Delta Count by Category						
	Stable	Minor	Acceptable	Marginal	Unstable	Open
mOhms	<=1	>1 & <=2	>2 & <=5	>5 & <=15	>15 & <=1000	>1000
Acid Vapor	32	0	0	0	0	0

EQUIPMENT AND CALIBRATION SCHEDULES**Equipment #:** HZ-THC-01**Description:** Humidity transmitter**Manufacturer:** Thermtron**Model:** SM-8-8200**Serial #:** 38846**Accuracy:** Last Cal: 2/28/2023, Next Cal: 2/27/2024**Equipment #:** HZ-TSC-01**Description:** Vertical Thermal Shock Chamber**Manufacturer:** Cincinnatti Sub Zero**Model:** VTS-3-6-6-SC/AC**Serial #:** 10-VT14994**Accuracy:** See Manual

... Last Cal: 06/28/2023, Next Cal: 06/27/2024

Equipment #: HZ-HPM-01**Description:** NA9636H**Manufacturer:** Ainuo**Model:** 6031A**Serial #:** 089601091**Accuracy:** Last Cal: 3/7/2023, Next Cal: 3/6/2024**Equipment #:** HZ-MO-05**Description:** Micro-ohmmeter**Manufacturer:** Keithley**Model:** 3706**Serial #:** 1285188**Accuracy:** Last Cal: 11/15/2022, Next Cal: 11/14/2023**Equipment #:** HZ-PS-01**Description:** Power Supply**Manufacturer:** Agilent**Model:** 6031A**Serial #:** MY41000982**Accuracy:** Last Cal: 04/28/2023, Next Cal: 04/28/2024