

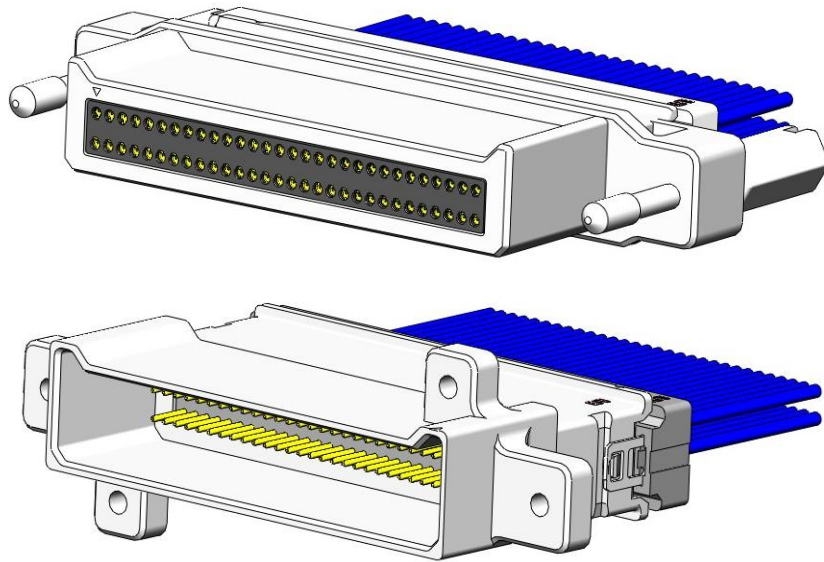

Project Number: Design Qualification Test Report	Tracking Code: CR-971602_Report_Rev_2
Requested by: Tyler Lang	Date: 3/29/2024
Part #: B1SDT-30-28-H-06.0/P1PDT-30-28-H-06.0	
Part description: B1SDT/P1PDT	Tech: Daniel Haydon
Test Start: 9/29/2023	Test Completed: 11/1/2023



DESIGN QUALIFICATION TEST REPORT
B1SDT/P1PDT
B1SDT-30-28-H-06.0/P1PDT-30-28-H-06.0

REVISION HISTORY

DATA	REV.NUM.	DESCRIPTION	ENG
11/28/2023	1	Initial test	KH
2/22/2024	2	Add the Shock-Vib test result.	KH

CERTIFICATION

All instruments and measuring equipment were calibrated to National Institute for Standards and Technology (NIST) traceable standards according to ISO 10012-1 and ANSI/NCSL 2540-1, as applicable.

All contents contained herein are the property of Samtec. No portion of this report, in part or in full shall be reproduced without prior written approval of Samtec.

SCOPE

To perform the following tests: Design Qualification test. Please see test plan.

APPLICABLE DOCUMENTS

Standards: EIA Publication 364

TEST SAMPLES AND PREPARATION

- 1) All materials were manufactured in accordance with the applicable product specification.
- 2) All test samples were identified and encoded to maintain traceability throughout the test sequences.
- 3) After soldering, the parts to be used for LLCR and DWV/IR testing were cleaned according to CO-SC-WI-3029.
- 4) Either an automated cleaning procedure or an ultrasonic cleaning procedure may be used.
- 5) The automated procedure is used with aqueous compatible soldering materials.
- 6) Parts not intended for testing LLCR and DWV/IR are visually inspected and cleaned if necessary.
- 7) Any additional preparation will be noted in the individual test sequences.
- 8) Solder Information: Lead Free
- 9) Samtec Test PCBs used: PCB-111718-TST-XX /PCB-112867-TST-XX/PCB-112966-TST-XX/
PCB-103219-TST.

FLOWCHARTS**Gas Tight**Group 1

B1SDT-30-28-H-06.0

P1PDT-30-28-H-06.0

8 Assemblies

Step Description

1. LLCR ⁽²⁾
2. Gas Tight ⁽¹⁾
3. LLCR ⁽²⁾
Max Delta = 15 mOhm

 (1) Gas Tight = EIA-364-36

(2) LLCR = EIA-364-23

Open Circuit Voltage = 20 mV Max

Test Current = 100 mA Max

Normal Force*Note: Removed signal without thermal because being tested with B1SDT & P1M*Group 1

C-508-01-H

T-1M145-01-H

8 Contacts Minimum

Signal With Thermals

Step Description

1. Contact Gaps
2. Thermal Age ⁽²⁾
3. Contact Gaps
4. Normal Force ⁽¹⁾
Deflection = 0.003 "
Expected Force at Max Deflection = 50 g

 (1) Normal Force = EIA-364-04

(2) Thermal Age = EIA-364-17

Test Condition = 4 (105°C)

Time Condition = B (250 Hours)

FLOWCHARTS Continued**Thermal Aging**Group 1

B1SDT-30-28-H-06.0

P1PDT-30-28-H-06.0

8 Assemblies

Step	Description
1.	Mating/Unmating Force ⁽²⁾
2.	LLCR ⁽¹⁾
3.	Thermal Age ⁽³⁾
4.	LLCR ⁽¹⁾ Max Delta = 15 mOhm
5.	Mating/Unmating Force ⁽²⁾

(1) LLCR = EIA-364-23

Open Circuit Voltage = 20 mV Max
Test Current = 100 mA Max

(2) Mating/Unmating Force = EIA-364-13

(3) Thermal Age = EIA-364-17

Test Condition = 4 (105°C)
Time Condition = B (250 Hours)

FLOWCHARTS Continued

Mating/Unmating/Durability

Group 1

B1SDT-30-28-H-06.0
P1PDT-30-28-H-06.0
8 Assemblies

Step	Description
1.	LLCR ⁽²⁾
2.	Mating/Unmating Force ⁽³⁾
3.	Cycles Quantity = 25 Cycles
4.	Mating/Unmating Force ⁽³⁾
5.	Cycles Quantity = 25 Cycles
6.	Mating/Unmating Force ⁽³⁾
7.	Cycles Quantity = 25 Cycles
8.	Mating/Unmating Force ⁽³⁾
9.	Cycles Quantity = 25 Cycles
10.	Mating/Unmating Force ⁽³⁾
11.	LLCR ⁽²⁾ Max Delta = 15 mOhm
12.	Thermal Shock ⁽⁴⁾
13.	LLCR ⁽²⁾ Max Delta = 15 mOhm
14.	Humidity ⁽¹⁾
15.	LLCR ⁽²⁾ Max Delta = 15 mOhm
16.	Mating/Unmating Force ⁽³⁾

Group 2

B1SDT-10-28-H-06.0
P1PDT-10-28-H-06.0
8 Assemblies

Step	Description
1.	Mating/Unmating Force ⁽³⁾
2.	Cycles Quantity = 25 Cycles
3.	Mating/Unmating Force ⁽³⁾
4.	Cycles Quantity = 25 Cycles
5.	Mating/Unmating Force ⁽³⁾
6.	Cycles Quantity = 25 Cycles
7.	Mating/Unmating Force ⁽³⁾
8.	Cycles Quantity = 25 Cycles
9.	Mating/Unmating Force ⁽³⁾

-
- (1) Humidity = EIA-364-31
 Test Condition = B (240 Hours)
 Test Method = III (+25°C to +65°C @ 90% RH to 98% RH)
 Test Exceptions: ambient pre-condition and delete steps 7a and 7b
 - (2) LLCR = EIA-364-23
 Open Circuit Voltage = 20 mV Max
 Test Current = 100 mA Max
 - (3) Mating/Unmating Force = EIA-364-13
 - (4) Thermal Shock = EIA-364-32
 Exposure Time at Temperature Extremes = 1/2 Hour
 Method A, Test Condition = I (-55°C to +85°C)
 Test Duration = A-3 (100 Cycles)

FLOWCHARTS Continued

IR/DWV

Pin-to-Pin

<u>Group 1</u>		<u>Group 2</u>		<u>Group 3</u>		<u>Group 4</u>	
B1SDT-30-28-H-06.0 P1PDT-30-28-H-06.0 2 Assemblies		B1SDT-30-28-H-06.0 2 Assemblies		P1PDT-30-28-H-06.0 2 Assemblies		B1SDT-30-28-H-06.0 P1PDT-30-28-H-06.0 2 Assemblies	
Step	Description	Step	Description	Step	Description	Step	Description
1.	DWV Breakdown (2)	1.	DWV Breakdown (2)	1.	DWV Breakdown (2)	1.	IR (4)
						2.	DWV at Test Voltage (1)
						3.	Thermal Shock (5)
						4.	IR (4)
						5.	DWV at Test Voltage (1)
						6.	Humidity (3)
						7.	IR (4)
						8.	DWV at Test Voltage (1)

Row-to-Row

<u>Group 5</u>		<u>Group 6</u>		<u>Group 7</u>		<u>Group 8</u>	
B1SDT-30-28-H-06.0 P1PDT-30-28-H-06.0 2 Assemblies		B1SDT-30-28-H-06.0 2 Assemblies		P1PDT-30-28-H-06.0 2 Assemblies		B1SDT-30-28-H-06.0 P1PDT-30-28-H-06.0 2 Assemblies	
Step	Description	Step	Description	Step	Description	Step	Description
1.	DWV Breakdown (2)	1.	DWV Breakdown (2)	1.	DWV Breakdown (2)	1.	IR (4)
						2.	DWV at Test Voltage (1)
						3.	Thermal Shock (5)
						4.	IR (4)
						5.	DWV at Test Voltage (1)
						6.	Humidity (3)
						7.	IR (4)
						8.	DWV at Test Voltage (1)

- (1) DWV at Test Voltage = EIA-364-20
 Test Condition = 1 (Sea Level)
 DWV test voltage is equal to 75% of the lowest breakdown voltage
 Test voltage applied for 60 seconds
- (2) DWV Breakdown = EIA-364-20
 Test Condition = 1 (Sea Level)
 DWV test voltage is equal to 75% of the lowest breakdown voltage
 Test voltage applied for 60 seconds
- (3) Humidity = EIA-364-31
 Test Condition = B (240 Hours)
 Test Method = III (+25°C to +65°C @ 90% RH to 98% RH)
 Test Exceptions: ambient pre-condition and delete steps 7a and 7b
- (4) IR = EIA-364-21
 Test Condition = 500 Vdc, 2 Minutes Max
- (5) Thermal Shock = EIA-364-32
 Exposure Time at Temperature Extremes = 1/2 Hour
 Method A, Test Condition = I (-55°C to +85°C)
 Test Duration = A-3 (100 Cycles)

FLOWCHARTS Continued

Current Carrying Capacity

<p style="text-align: center;"><u>Group 1</u></p> <p style="text-align: center;">B1SDT-30-28-H-12.0-2 P1PDT-30-28-H-12.0-B-2 2 Pins Powered Signal</p> <hr/> <table style="width: 100%; border-collapse: collapse;"> <thead> <tr> <th style="text-align: left;">Step</th> <th style="text-align: left;">Description</th> </tr> </thead> <tbody> <tr> <td style="vertical-align: top;">1.</td> <td>CCC ⁽¹⁾ Rows = 2 Number of Positions = 1</td> </tr> </tbody> </table>	Step	Description	1.	CCC ⁽¹⁾ Rows = 2 Number of Positions = 1	<p style="text-align: center;"><u>Group 2</u></p> <p style="text-align: center;">B1SDT-30-28-H-12.0-2 P1PDT-30-28-H-12.0-B-2 4 Pins Powered Signal</p> <hr/> <table style="width: 100%; border-collapse: collapse;"> <thead> <tr> <th style="text-align: left;">Step</th> <th style="text-align: left;">Description</th> </tr> </thead> <tbody> <tr> <td style="vertical-align: top;">1.</td> <td>CCC ⁽¹⁾ Rows = 2 Number of Positions = 2</td> </tr> </tbody> </table>	Step	Description	1.	CCC ⁽¹⁾ Rows = 2 Number of Positions = 2	<p style="text-align: center;"><u>Group 3</u></p> <p style="text-align: center;">B1SDT-30-28-H-12.0-2 P1PDT-30-28-H-12.0-B-2 6 Pins Powered Signal</p> <hr/> <table style="width: 100%; border-collapse: collapse;"> <thead> <tr> <th style="text-align: left;">Step</th> <th style="text-align: left;">Description</th> </tr> </thead> <tbody> <tr> <td style="vertical-align: top;">1.</td> <td>CCC ⁽¹⁾ Rows = 2 Number of Positions = 3</td> </tr> </tbody> </table>	Step	Description	1.	CCC ⁽¹⁾ Rows = 2 Number of Positions = 3	<p style="text-align: center;"><u>Group 4</u></p> <p style="text-align: center;">B1SDT-30-28-H-12.0-2 P1PDT-30-28-H-12.0-B-2 8 Pins Powered Signal</p> <hr/> <table style="width: 100%; border-collapse: collapse;"> <thead> <tr> <th style="text-align: left;">Step</th> <th style="text-align: left;">Description</th> </tr> </thead> <tbody> <tr> <td style="vertical-align: top;">1.</td> <td>CCC ⁽¹⁾ Rows = 2 Number of Positions = 4</td> </tr> </tbody> </table>	Step	Description	1.	CCC ⁽¹⁾ Rows = 2 Number of Positions = 4
Step	Description																		
1.	CCC ⁽¹⁾ Rows = 2 Number of Positions = 1																		
Step	Description																		
1.	CCC ⁽¹⁾ Rows = 2 Number of Positions = 2																		
Step	Description																		
1.	CCC ⁽¹⁾ Rows = 2 Number of Positions = 3																		
Step	Description																		
1.	CCC ⁽¹⁾ Rows = 2 Number of Positions = 4																		

<p style="text-align: center;"><u>Group 5</u></p> <p style="text-align: center;">B1SDT-30-28-H-12.0-2 P1PDT-30-28-H-12.0-B-2 60 Pins Powered Signal</p> <hr/> <table style="width: 100%; border-collapse: collapse;"> <thead> <tr> <th style="text-align: left;">Step</th> <th style="text-align: left;">Description</th> </tr> </thead> <tbody> <tr> <td style="vertical-align: top;">1.</td> <td>CCC ⁽¹⁾ Rows = 2 Number of Positions = 30</td> </tr> </tbody> </table>	Step	Description	1.	CCC ⁽¹⁾ Rows = 2 Number of Positions = 30
Step	Description			
1.	CCC ⁽¹⁾ Rows = 2 Number of Positions = 30			

(1) CCC = EIA-364-70
Method 2, Temperature Rise Versus Current Curve
(TIN PLATING) - Tabulate calculated current at RT, 65°C, 75°C and 95°C after derating 20% and based on 105°C
(GOLD PLATING) - Tabulate calculated current at RT, 85°C, 95°C and 115°C after derating 20% and based on 125°C

Cable Pull

<p style="text-align: center;"><u>Group 1</u></p> <p style="text-align: center;">B1SDT-10-28-H-12.0-2 P1PDT-10-28-H-12.0-B-2 5 Assemblies 0 Degrees</p> <hr/> <table style="width: 100%; border-collapse: collapse;"> <thead> <tr> <th style="text-align: left;">Step</th> <th style="text-align: left;">Description</th> </tr> </thead> <tbody> <tr> <td style="vertical-align: top;">1.</td> <td>Cable Pull ⁽¹⁾</td> </tr> </tbody> </table>	Step	Description	1.	Cable Pull ⁽¹⁾	<p style="text-align: center;"><u>Group 2</u></p> <p style="text-align: center;">B1SDT-10-28-H-12.0-2 P1PDT-10-28-H-12.0-B-2 5 Assemblies 90 Degrees</p> <hr/> <table style="width: 100%; border-collapse: collapse;"> <thead> <tr> <th style="text-align: left;">Step</th> <th style="text-align: left;">Description</th> </tr> </thead> <tbody> <tr> <td style="vertical-align: top;">1.</td> <td>Cable Pull ⁽¹⁾</td> </tr> </tbody> </table>	Step	Description	1.	Cable Pull ⁽¹⁾
Step	Description								
1.	Cable Pull ⁽¹⁾								
Step	Description								
1.	Cable Pull ⁽¹⁾								

(1) Cable Pull = EIA-364-38
Measure and Record Force Required to Failure
Failure = Discontinuity >1 microsecond at 10 ohms

FLOWCHARTS Continued

Cable Flex

Group 1

B1SDT-10-28-H-12.0-2

P1PDT-10-28-H-12.0-2

8 Assemblies

Circular Cable

Step	Description
1.	IR ⁽³⁾
2.	DWV at Test Voltage ⁽²⁾
3.	Cable Flex ⁽¹⁾
4.	Visual Inspection
5.	IR ⁽³⁾
6.	DWV at Test Voltage ⁽²⁾
7.	Rotate Cable 90°
8.	Cable Flex ⁽¹⁾
9.	Visual Inspection
10.	IR ⁽³⁾
11.	DWV at Test Voltage ⁽²⁾

 (1) Cable Flex = EIA-364-41

Circular Jacket Cable - to be tested 90° each direction (180° total)

Flat Cable - to be tested 70° each direction (140° total)

Monitor continuity during flex testing

Failure = Discontinuity >1 microsecond at 10 ohms

(2) DWV at Test Voltage = EIA-364-20

Test Condition = 1 (Sea Level)

DWV test voltage is equal to 75% of the lowest breakdown voltage

Test voltage applied for 60 seconds

(3) IR = EIA-364-21

Test Condition = 500 Vdc, 2 Minutes Max

FLOWCHARTS Continued**Mechanical Shock/Random Vibration/LLCR**Group 1

B1SDT-30-28-H-12.0

P1PDT-30-28-H-12.0

8 Assemblies

Step	Description
1.	LLCR ⁽¹⁾
2.	Mechanical Shock ⁽²⁾
3.	Random Vibration ⁽³⁾
4.	LLCR ⁽¹⁾ Max Delta = 15 mOhm

(1) LLCR = EIA-364-23

Open Circuit Voltage = 20 mV Max

Test Current = 100 mA Max

(2) Mechanical Shock = EIA-364-27

Test Condition = C (100 G Peak, 6 milliseconds, Half Sine)

Number of Shocks = 3 Per Direction, Per Axis, 18 Total

(3) Random Vibration = EIA-364-28

Condition = VB (7.56 gRMS Average, 2 Hours/Axis)

Mechanical Shock/Random Vibration/Event DetectionGroup 1

B1SDT-30-28-H-12.0

P1PDT-30-28-H-12.0

60 Points

Step	Description
1.	Nanosecond Event Detection (Mechanical Shock) ⁽¹⁾
2.	Nanosecond Event Detection (Random Vibration) ⁽²⁾

(1) Nanosecond Event Detection (Mechanical Shock)

Use EIA-364-87 for Nanosecond Event Detection:

Test Condition = F (50 nanoseconds at 10 ohms)

Use EIA-364-27 for Mechanical Shock:

Test Condition = C (100 G Peak, 6 milliseconds, Half Sine)

Number of Shocks = 3 Per Direction, Per Axis, 18 Total

(2) Nanosecond Event Detection (Random Vibration)

Use EIA-364-87 for Nanosecond Event Detection:

Test Condition = F (50 nanoseconds at 10 ohms)

Use EIA-364-28 for Random Vibration:

Condition = VB (7.56 gRMS Average, 2 Hours/Axis)

ATTRIBUTE DEFINITIONS

The following is a brief, simplified description of attributes.

THERMAL:

- 1) EIA-364-17, *Temperature Life with or without Electrical Load Test Procedure for Electrical Connectors*.
- 2) Test Condition at 105° C.
- 3) Test Time Condition B for 250 hours.
- 4) All test samples are pre-conditioned at ambient.
- 5) All test samples are exposed to environmental stressing in the mated condition.

THERMAL SHOCK:

- 1) EIA-364-32, *Thermal Shock (Temperature Cycling) Test Procedure for Electrical Connectors*.
- 2) Test Condition I: -55°C to +85°C.
- 3) Test Time: ½ hour dwell at each temperature extreme.
- 4) Number of Cycles: 100
- 5) All test samples are pre-conditioned at ambient.
- 6) All test samples are exposed to environmental stressing in the mated condition.

HUMIDITY:

- 1) Reference document: EIA-364-31, *Humidity Test Procedure for Electrical Connectors*.
- 2) Test Condition B, 240 Hours.
- 3) Method III, +25° C to + 65° C, 90% to 98% Relative Humidity excluding sub-cycles 7a and 7b.
- 4) All samples are pre-conditioned at ambient.
- 5) All test samples are exposed to environmental stressing in the mated condition.

MECHANICAL SHOCK (Specified Pulse):

- 1) Reference document: EIA-364-27, *Mechanical Shock Test Procedure for Electrical Connectors*
- 2) Test Condition C
- 3) Peak Value: 100 G
- 4) Duration: 6 Milliseconds
- 5) Wave Form: Half Sine
- 6) Velocity: 12.3 ft/s
- 7) Number of Shocks: 3 Shocks / Direction, 3 Axis (18 Total)

VIBRATION:

- 1) Reference document: EIA-364-28, *Vibration Test Procedure for Electrical Connectors*
- 2) Test Condition V, Letter B
- 3) Power Spectral Density: 0.04 G² / Hz
- 4) G 'RMS': 7.56
- 5) Frequency: 50 to 2000 Hz
- 6) Duration: 2.0 Hours per axis (3 axis total)

NANOSECOND-EVENT DETECTION:

- 1) Reference document: EIA-364-87, *Nanosecond-Event Detection for Electrical Connectors*
- 2) Prior to test, the samples were characterized to assure the low nanosecond event being monitored will trigger the detector.
- 3) After characterization it was determined the test samples could be monitored for 50 nanosecond events

MATING/UNMATING:

- 1) Reference document: EIA-364-13, *Mating and Unmating Forces Test Procedure for Electrical Connectors*.
- 2) The full insertion position was to within 0.003" to 0.004" of the plug bottoming out in the receptacle to prevent damage to the system under test.
- 3) One of the mating parts is secured to a floating X-Y table to prevent damage during cycling.

ATTRIBUTE DEFINITIONS Continued

The following is a brief, simplified description of attributes.

TEMPERATURE RISE (Current Carrying Capacity, CCC):

- 1) EIA-364-70, *Temperature Rise versus Current Test Procedure for Electrical Connectors and Sockets*.
- 2) When current passes through a contact, the temperature of the contact increases as a result of I^2R (resistive) heating.
- 3) The number of contacts being investigated plays a significant part in power dissipation and therefore temperature rise.
- 4) The size of the temperature probe can affect the measured temperature.
- 5) Copper traces on PC boards will contribute to temperature rise:
 - a. Self-heating (resistive)
 - b. Reduction in heat sink capacity affecting the heated contacts.
- 6) A de-rating curve, usually 20%, is calculated.
- 7) Calculated de-rated currents at four temperature points are reported:
 - a. Ambient
 - b. 85° C
 - c. 95° C
 - d. 115° C
- 8) Typically, neighboring contacts (in close proximity to maximize heat buildup) are energized.
- 9) The thermocouple (or temperature measuring probe) will be positioned at a location to sense the maximum temperature in the vicinity of the heat generation area.
- 10) A computer program, *TR 803.exe*, ensures accurate stability for data acquisition.
- 11) Hook-up wire cross section is larger than the cross section of any connector leads/PC board traces, jumpers, etc.
- 12) Hook-up wire length is longer than the minimum specified in the referencing standard.

NORMAL FORCE (FOR CONTACTS TESTED OUTSIDE THE HOUSING):

- 1) Reference document: EIA-364-04, *Normal Force Test Procedure for Electrical Connectors*.
- 2) The contacts shall be tested in the loose state, *not* inserted in connector housing.
- 3) The contacts shall be prepared to allow access to the spring member at the same attitude and deflection level as would occur in actual use.
- 4) In the event that portions of the contact prevent insertion of the test probe and/or deflection of the spring member under evaluation, said material shall be removed leaving the appropriate contact surfaces exposed.
- 5) In the case of multi-tine contacts, each tine shall be tested independently on separate samples as required.
- 6) The connector housing shall be simulated, if required, in order to provide an accurate representation of the actual contact system performance.
- 7) A holding fixture shall be fashioned to allow the contact to be properly deflected.
- 8) Said holding fixture shall be mounted on a floating, adjustable, X-Y table on the base of the Dillon TC², computer controlled test stand with a deflection measurement system accuracy of 5 μm (0.0002").
- 9) The probe shall be attached to a Dillon P/N 49761-0105, 5 N (1.1 Lb) load cell providing an accuracy of $\pm 0.2\%$.
- 10) The nominal deflection rate shall be 5 mm (0.2")/minute.
- 11) Unless otherwise noted a minimum of five contacts shall be tested.
- 12) The force/deflection characteristic to load and unload each contact shall be repeated five times.
- 13) The system shall utilize the TC² software in order to acquire and record the test data.
- 14) The permanent set of each contact shall be measured within the TC² software.
- 15) The acquired data shall be graphed with the deflection data on the X-axis and the force data on the Y-axis and a print out will be stored with the Tracking Code paperwork.

ATTRIBUTE DEFINITIONS Continued

The following is a brief, simplified description of attributes.

LLCR:

- 1) EIA-364-23, *Low Level Contact Resistance Test Procedure for Electrical Connectors and Sockets*.
- 2) A computer program, *LLCR 221.exe*, ensures repeatability for data acquisition.
- 3) The following guidelines are used to categorize the changes in LLCR as a result from stressing.
 - a. $\leq +5.0$ mOhms: -----Stable
 - b. $+5.1$ to $+10.0$ mOhms:-----Minor
 - c. $+10.1$ to $+15.0$ mOhms: -----Acceptable
 - d. $+15.1$ to $+50.0$ mOhms: -----Marginal
 - e. $+50.1$ to $+1000$ mOhms: -----Unstable
 - f. $>+1000$ mOhms:-----Open Failure

GAS TIGHT:

To provide method for evaluating the ability of the contacting surfaces in preventing penetration of harsh vapors which might lead to oxide formation that may degrade the electrical performance of the contact system.

- 1) EIA-364-23, *Low Level Contact Resistance Test Procedure for Electrical Connectors and Sockets*.
- 2) A computer program, *LLCR 221.exe*, ensures repeatability for data acquisition.
- 3) The following guidelines are used to categorize the changes in LLCR as a result from stressing.
 - a. $\leq +5.0$ mOhms:-----Stable
 - b. $+5.1$ to $+10.0$ mOhms: -----Minor
 - c. $+10.1$ to $+15.0$ mOhms: -----Acceptable
 - d. $+15.1$ to $+50.0$ mOhms: -----Marginal
 - e. $+50.1$ to $+1000$ mOhms:-----Unstable
 - f. $>+1000$ mOhms:-----Open Failure
- 4) Procedure:
 - a. Reference document: EIA-364-36, *Test Procedure for Determination of Gas-Tight Characteristics for Electrical Connectors, Sockets and/or Contact Systems*.
 - b. Test Conditions:
 - i. Class II-- Mated pairs of contacts assembled to their plastic housings.
 - ii. Reagent grade Nitric Acid shall be used of sufficient volume to saturate the test chamber.
 - iii. The ratio of the volume of the test chamber to the surface area of the acid shall be 10:1.
 - iv. The chamber shall be saturated with the vapor for at least 15 minutes before samples are added.
 - v. Exposure time, 55 to 65 minutes.
 - vi. The samples shall be no closer to the chamber walls than 1 inch and no closer to the surface of the acid than 3 inches.
 - vii. The samples shall be dried after exposure for a minimum of 1 hour.
 - viii. Drying temperature 50° C
 - ix. The final LLCR shall be conducted within 1 hour after drying.

ATTRIBUTE DEFINITIONS Continued

The following is a brief, simplified description of attributes.

INSULATION RESISTANCE (IR):

To determine the resistance of insulation materials to leakage of current through or on the surface of these materials when a DC potential is applied.

- 1) PROCEDURE:
 - a. Reference document: EIA-364-21, *Insulation Resistance Test Procedure for Electrical Connectors*.
 - b. Test Conditions:
 - i. Between Adjacent Contacts or Signal-to-Ground
 - ii. Electrification Time 2.0 minutes
 - iii. Test Voltage (500 VDC) corresponds to calibration settings for measuring resistances.
- 2) MEASUREMENTS:
- 3) When the specified test voltage is applied (VDC), the insulation resistance shall not be less than 1000 megohms.

DIELECTRIC WITHSTANDING VOLTAGE (DWV):

To determine if the sockets can operate at its rated voltage and withstand momentary over potentials due to switching, surges, and other similar phenomenon. Separate samples are used to evaluate the effect of environmental stresses so not to influence the readings from arcing that occurs during the measurement process.

- 1) PROCEDURE:
 - a. Reference document: EIA-364-20, *Withstanding Voltage Test Procedure for Electrical Connectors*.
 - b. Test Conditions:
 - i. Between Adjacent Contacts or Signal-to-Ground
 - ii. Barometric Test Condition 1
 - iii. Rate of Application 500 V/Sec
 - iv. Test Voltage (VAC) until breakdown occurs.
- 2) MEASUREMENTS/CALCULATIONS
 - a. The breakdown voltage shall be measured and recorded.
 - b. The dielectric withstanding voltage shall be recorded as 75% of the minimum breakdown voltage.
 - c. The working voltage shall be recorded as one-third (1/3) of the dielectric withstanding voltage (one-fourth of the breakdown voltage).

ATTRIBUTE DEFINITIONS Continued

The following is a brief, simplified description of attributes.

CABLE PULL:

- 1) Secure cable near center and pull-on connector.
 - a. At 0° , in-line with cable
 - b. At 90° , in-line with cable



Fig. 1
 0° Connector pull.



Fig. 2
 90° Connector pull.

CABLE Flex:

- 1) Oscillate and monitor electrical continuity for open circuit indication.
 - a. $\pm 70^\circ$ Flex Mode, bend up to 500 cycles. load on 12 oz.



Fig. 3
(Setup picture)

RESULTS

Temperature Rise, CCC at a 20% de-rating

- CCC for a 30°C Temperature Rise-----3.8 A per contact with 2 contact (2 x 1) powered.
- CCC for a 30°C Temperature Rise-----3.0 A per contact with 4 contacts (2 x 2) powered.
- CCC for a 30°C Temperature Rise-----2.7 A per contact with 6 contacts (2 x 3) powered.
- CCC for a 30°C Temperature Rise-----2.6 A per contact with 8 contacts (2 x 4) powered.
- CCC for a 30°C Temperature Rise-----1.1 A per contact with All contacts (2x30) powered.

Mating – Unmating Forces

Thermal Aging Group

- **Initial**
 - **Mating**
 - Min ----- 9.91 lbs
 - Max-----12.27 lbs
 - **Unmating**
 - Min ----- 8.82 lbs
 - Max-----10.98 lbs
- **After Thermal**
 - **Mating**
 - Min ----- 5.16 lbs
 - Max-----13.27 lbs
 - **Unmating**
 - Min ----- 7.71 lbs
 - Max----- 8.34 lbs

RESULTS Continued

Mating/Unmating Durability Group

- **Initial**
 - **Mating**
 - **Min** -----11.55 lbs
 - **Max** -----13.08 lbs
 - **Unmating**
 - **Min** ----- 6.40 lbs
 - **Max** -----12.22 lbs
- **After 25 Cycles**
 - **Mating**
 - **Min** ----- 9.31 lbs
 - **Max** -----10.70 lbs
 - **Unmating**
 - **Min** ----- 4.75 lbs
 - **Max** ----- 9.44 lbs
- **After 50 Cycles**
 - **Mating**
 - **Min** ----- 9.28 lbs
 - **Max** -----10.65 lbs
 - **Unmating**
 - **Min** ----- 4.71 lbs
 - **Max** ----- 8.74 lbs
- **After 75 Cycles**
 - **Mating**
 - **Min** ----- 9.28 lbs
 - **Max** -----10.72 lbs
 - **Unmating**
 - **Min** ----- 4.64 lbs
 - **Max** ----- 8.89 lbs
- **After 100 Cycles**
 - **Mating**
 - **Min** ----- 9.36 lbs
 - **Max** -----11.08 lbs
 - **Unmating**
 - **Min** ----- 4.63 lbs
 - **Max** ----- 9.29 lbs
- **After Humidity**
 - **Mating**
 - **Min** ----- 8.13 lbs
 - **Max** -----10.12 lbs
 - **Unmating**
 - **Min** ----- 7.40 lbs
 - **Max** ----- 9.98 lbs

RESULTS Continued

Mating/Unmating Basic (B1SDT-10-28-H-06.0/ P1PDT-10-28-H-06.0)

- **Initial**
 - **Mating**
 - **Min** ----- 3.43 lbs
 - **Max** ----- 4.36 lbs
 - **Unmating**
 - **Min** ----- 3.01 lbs
 - **Max** ----- 3.87 lbs
- **After 25 Cycles**
 - **Mating**
 - **Min** ----- 3.09 lbs
 - **Max** ----- 3.97 lbs
 - **Unmating**
 - **Min** ----- 2.73 lbs
 - **Max** ----- 3.20 lbs
- **After 50 Cycles**
 - **Mating**
 - **Min** ----- 3.22 lbs
 - **Max** ----- 4.12 lbs
 - **Unmating**
 - **Min** ----- 2.66 lbs
 - **Max** ----- 3.06 lbs
- **After 75 Cycles**
 - **Mating**
 - **Min** ----- 3.28 lbs
 - **Max** ----- 3.86 lbs
 - **Unmating**
 - **Min** ----- 2.63 lbs
 - **Max** ----- 3.03 lbs
- **After 100 Cycles**
 - **Mating**
 - **Min** ----- 3.38 lbs
 - **Max** ----- 3.96 lbs
 - **Unmating**
 - **Min** ----- 2.68 lbs
 - **Max** ----- 3.04 lbs

Cable Pull force:

- **0° Pull**
 - **Min** ----- 32.31 lbs
 - **Max** ----- 52.66 lbs
- **90° Pull**
 - **Min** ----- 19.52 lbs
 - **Max** ----- 21.08 lbs

Normal Force at 0.0016 inches deflection

- **After Thermal**
 - **Min** ----- 98.00 gf **Set**----- 0.0000 inch.
 - **Max** ----- 110.40 gf **Set**----- 0.0001 inch.

RESULTS Continued

Insulation Resistance minimums, IR

Pin to Pin

- **Initial**
 - Mated -----45000 Meg Ω ----- Passed
 - Unmated -----45000 Meg Ω ----- Passed
- **Thermal Shock**
 - Mated -----45000 Meg Ω ----- Passed
 - Unmated -----45000 Meg Ω ----- Passed
- **Humidity**
 - Mated -----45000 Meg Ω ----- Passed
 - Unmated -----45000 Meg Ω ----- Passed

Row to Row

- **Initial**
 - Mated -----45000 Meg Ω ----- Passed
 - Unmated -----45000 Meg Ω ----- Passed
- **Thermal Shock**
 - Mated -----45000 Meg Ω ----- Passed
 - Unmated -----45000 Meg Ω ----- Passed
- **Humidity**
 - Mated -----45000 Meg Ω ----- Passed
 - Unmated -----45000 Meg Ω ----- Passed

Dielectric Withstanding Voltage minimums, DWV

- **Minimums**
 - Breakdown Voltage -----800 VAC
 - Test Voltage -----600 VAC
 - Working Voltage -----200 VAC

Pin to Pin

- Initial DWV -----Passed
- Thermal DWV -----Passed
- Humidity DWV -----Passed

Row to Row

- Initial DWV -----Passed
- Thermal DWV -----Passed
- Humidity DWV -----Passed

RESULTS Continued

Cable Flex:

Insulation Resistance minimums, IR

Pin to Pin

- **Initial**
 - Mated-----45000 Meg Ω ----- Passed
- **After 500 flex cycles**
 - Mated-----45000 Meg Ω ----- Passed

Rotate Cable 90°

- **After 500 flex cycles**
 - Mated-----45000 Meg Ω ----- Passed

Row to Row

- **Initial**
 - Mated-----45000 Meg Ω ----- Passed
- **After 500 flex cycles**
 - Mated-----45000 Meg Ω ----- Passed

Rotate Cable 90°

- **After 500 flex cycles**
 - Mated-----45000 Meg Ω ----- Passed

Dielectric Withstanding Voltage minimums, DWV

- Breakdown Voltage-----800 VAC
- Test Voltage -----600 VAC
- Working Voltage -----200 VAC

Pin to Pin

- **Initial DWV -----Passed**
- **After 500 Flex cycles DWV -----Passed**

Rotate Cable 90°

- **After 500 Flex cycles DWV -----Passed**

Row to Row

- **Initial DWV -----Passed**
- **After 500 Flex cycles DWV -----Passed**

Rotate Cable 90°

- **After 500 Flex cycles DWV -----Passed**

RESULTS Continued

LLCR Gas Tight (192 LLCR test points)

- **Initial** ----- 70.65 mOhms Max
- **Gas-Tight**
 - <= +5.0 mOhms-----192 Points ----- Stable
 - +5.1 to +10.0 mOhms -----0 Points ----- Minor
 - +10.1 to +15.0 mOhms -----0 Points ----- Acceptable
 - +15.1 to +50.0 mOhms -----0 Points ----- Marginal
 - +50.1 to +1000 mOhms-----0 Points ----- Unstable
 - >+1000 mOhms-----0 Points ----- Open Failure

LLCR Thermal Aging (192 LLCR test points)

- **Initial** ----- 68.15 mOhms Max
- **Thermal Aging**
 - <= +5.0 mOhms-----192 Points ----- Stable
 - +5.1 to +10.0 mOhms -----0 Points ----- Minor
 - +10.1 to +15.0 mOhms -----0 Points ----- Acceptable
 - +15.1 to +50.0 mOhms -----0 Points ----- Marginal
 - +50.1 to +1000 mOhms-----0 Points ----- Unstable
 - >+1000 mOhms-----0 Points ----- Open Failure

LLCR Durability (192 LLCR test points)

- **Initial** ----- 66.20 mOhms Max
- **Durability, 100 Cycles**
 - <= +5.0 mOhms-----192 Points ----- Stable
 - +5.1 to +10.0 mOhms -----0 Points ----- Minor
 - +10.1 to +15.0 mOhms -----0 Points ----- Acceptable
 - +15.1 to +50.0 mOhms -----0 Points ----- Marginal
 - +50.1 to +1000 mOhms-----0 Points ----- Unstable
 - >+1000 mOhms-----0 Points ----- Open Failure
- **Thermal**
 - <= +5.0 mOhms-----190 Points ----- Stable
 - +5.1 to +10.0 mOhms -----2 Points ----- Minor
 - +10.1 to +15.0 mOhms -----0 Points ----- Acceptable
 - +15.1 to +50.0 mOhms -----0 Points ----- Marginal
 - +50.1 to +1000 mOhms-----0 Points ----- Unstable
 - >+1000 mOhms-----0 Points ----- Open Failure
- **Humidity**
 - <= +5.0 mOhms-----189 Points ----- Stable
 - +5.1 to +10.0 mOhms -----3 Points ----- Minor
 - +10.1 to +15.0 mOhms -----0 Points ----- Acceptable
 - +15.1 to +50.0 mOhms -----0 Points ----- Marginal
 - +50.1 to +1000 mOhms-----0 Points ----- Unstable
 - >+1000 mOhms-----0 Points ----- Open Failure

RESULTS Continued

LLCR Shock & Vibration (192 LLCR test points)

- **Initial ----- 131.79 mOhms Max**
- **Shock & Vibration**
 - **<= +5.0 mOhms ----- 191 Points ----- Stable**
 - **+5.1 to +10.0 mOhms ----- 1 Points ----- Minor**
 - **+10.1 to +15.0 mOhms ----- 0 Points ----- Acceptable**
 - **+15.1 to +50.0 mOhms ----- 0 Points ----- Marginal**
 - **+50.1 to +1000 mOhms ----- 0 Points ----- Unstable**
 - **>+1000 mOhms ----- 0 Points ----- Open Failure**

Mechanical Shock & Random Vibration:

- **Shock**
 - **No Damage ----- Pass**
 - **50 Nanoseconds ----- Pass**
- **Vibration**
 - **No Damage ----- Pass**
 - **50 Nanoseconds ----- Pass**

DATA SUMMARIES

TEMPERATURE RISE (Current Carrying Capacity, CCC):

- 1) High quality thermocouples whose temperature slopes track one another were used for temperature monitoring.
- 2) The thermocouples were placed at a location to sense the maximum temperature generated during testing.
- 3) Temperature readings recorded are those for which three successive readings, 15 minutes apart, differ less than 1° C (computer-controlled data acquisition).
- 4) Adjacent contacts were powered:
 - a. Linear configuration with 2 adjacent conductors/contacts powered.

CR-971602
2 (2x1) Contacts in Series
Part Numbers: B1SDT-30-28-H-12.0-2/P1PDT-30-28-H-12.0-B-2

Current Rating per Contact (30 Deg. Rise, 20% Derated) = 3.8 Amps

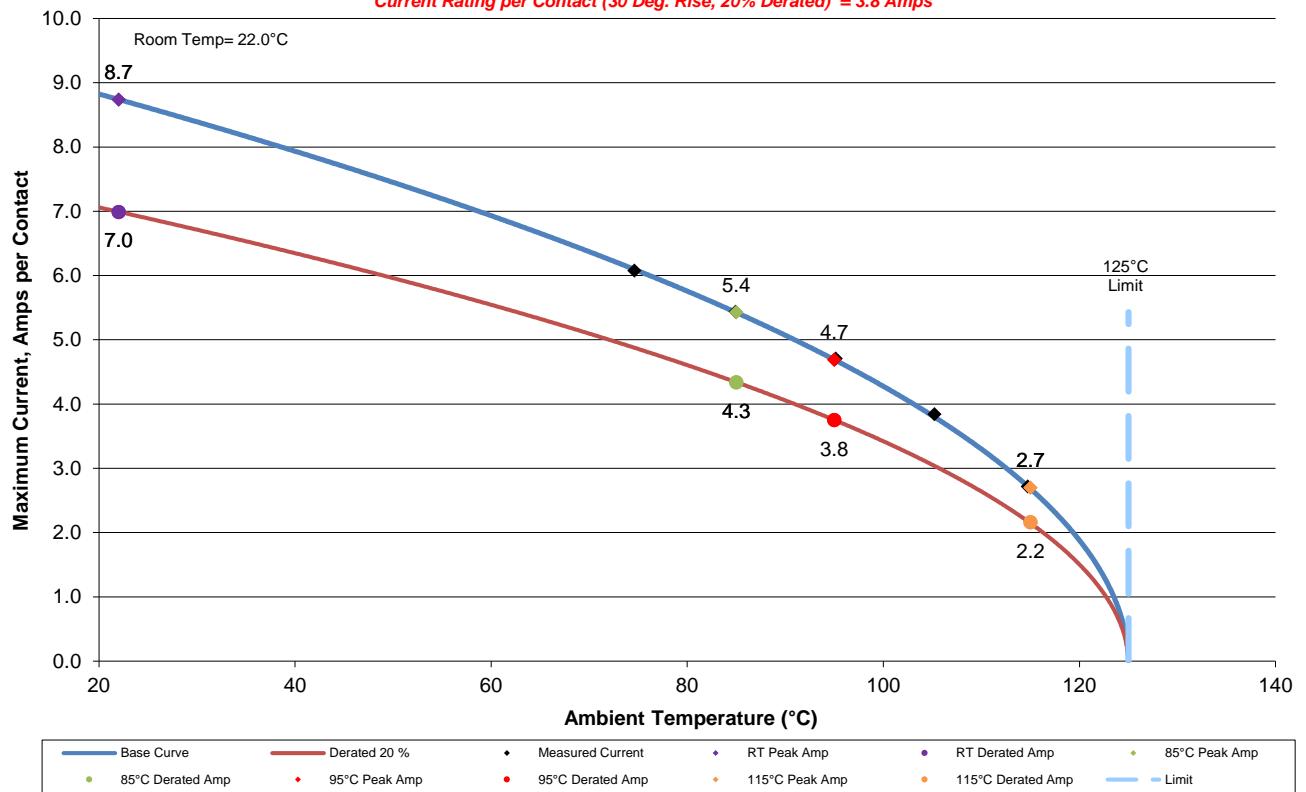

DATA SUMMARIES Continued

CR-971602
2 (2x1) Contacts in Series
Part Numbers: B1SDT-30-28-H-12.0-2/P1PDT-30-28-H-12.0-B-2

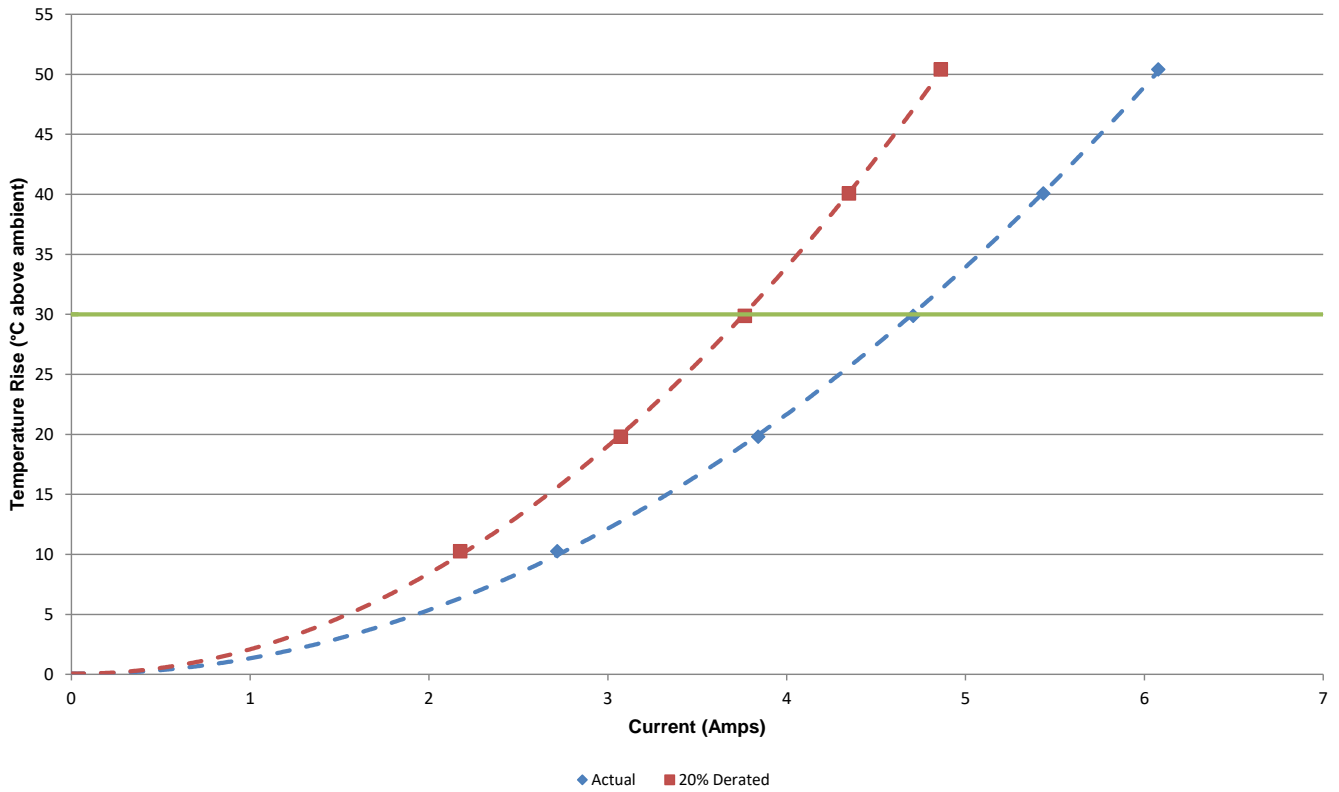

DATA SUMMARIES Continued

b. Linear configuration with 4 adjacent conductors/contacts powered.

CR-971602
4 (2x2) Contacts in Series
Part Numbers: B1SDT-30-28-H-12.0-2/P1PDT-30-28-H-12.0-B-2

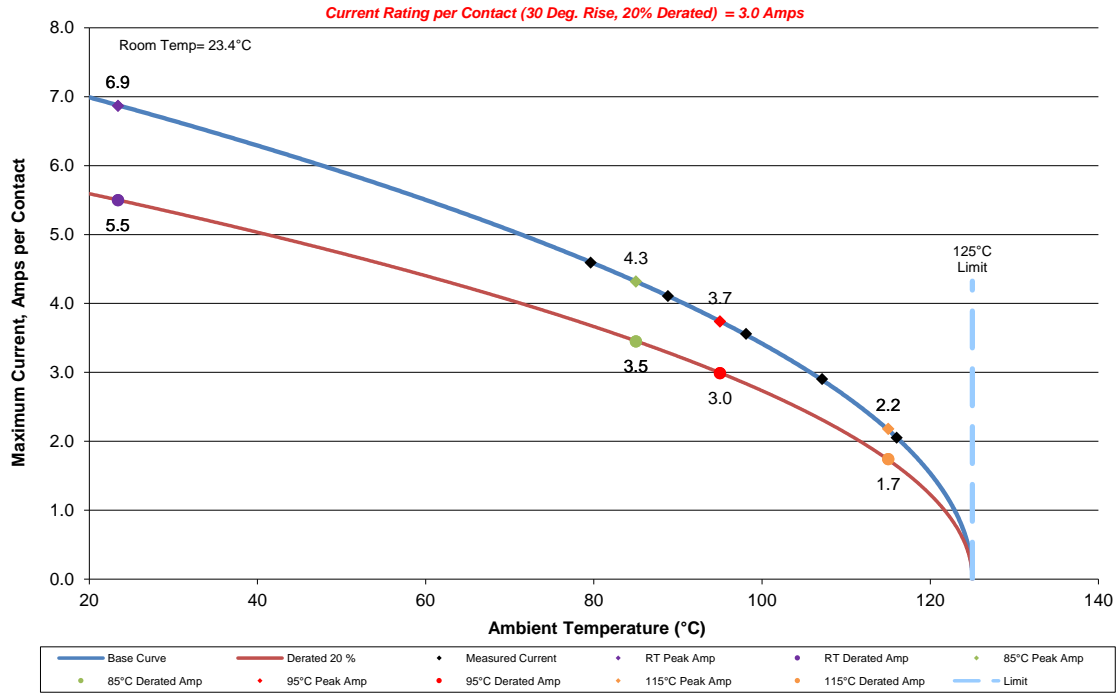

CR-971602
4 (2x2) Contacts in Series
Part Numbers: B1SDT-30-28-H-12.0-2/P1PDT-30-28-H-12.0-B-2

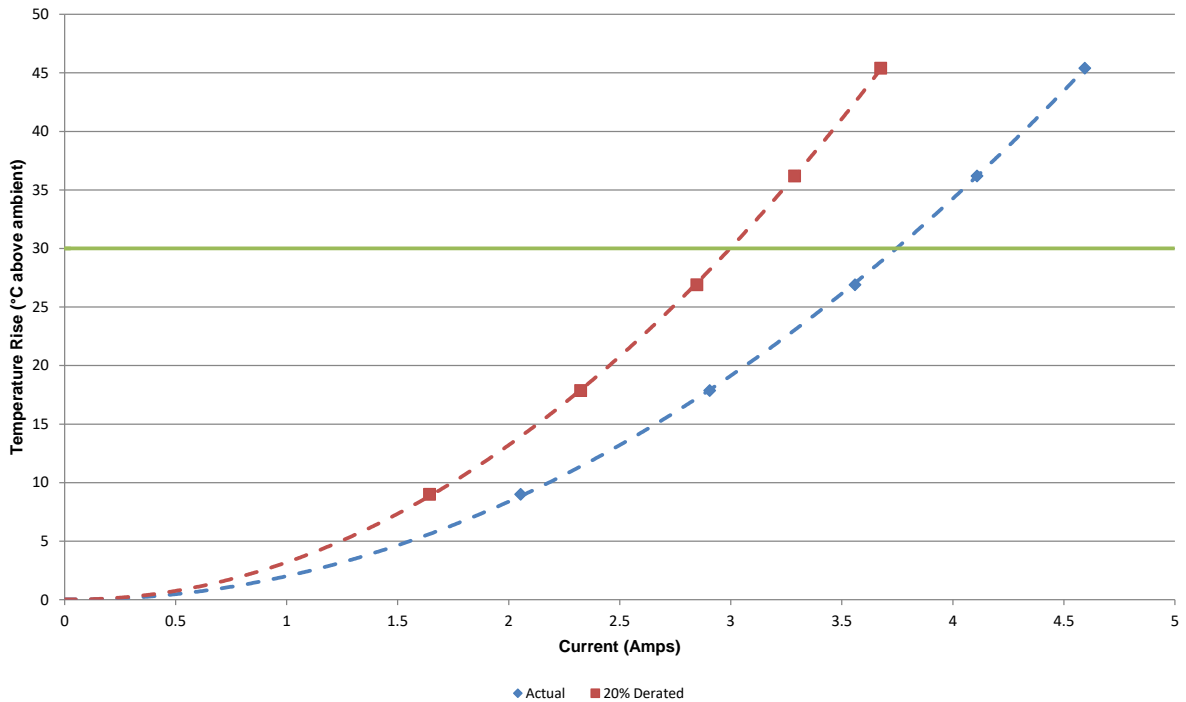

DATA SUMMARIES Continued

c. Linear configuration with 6 adjacent conductors/contacts powered.

CR-971602
6 (2x3) Contacts in Series
Part Numbers: B1SDT-30-28-H-12.0-2/P1PDT-30-28-H-12.0-B-2

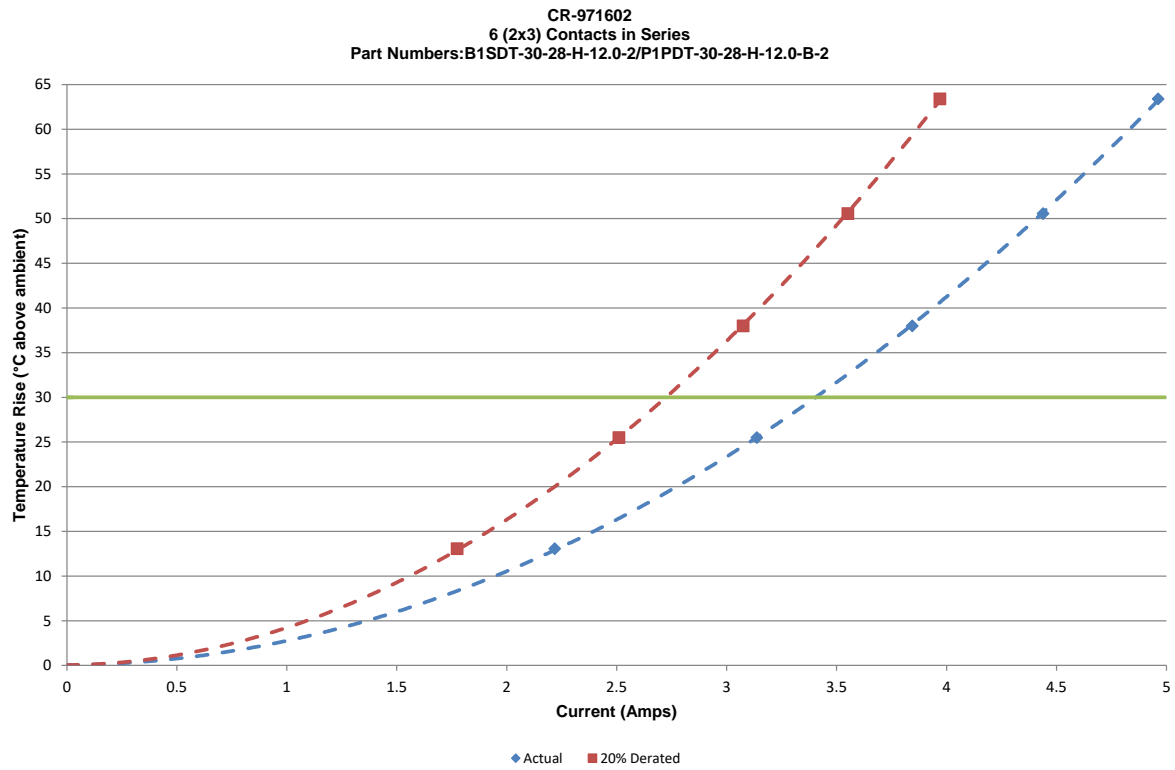
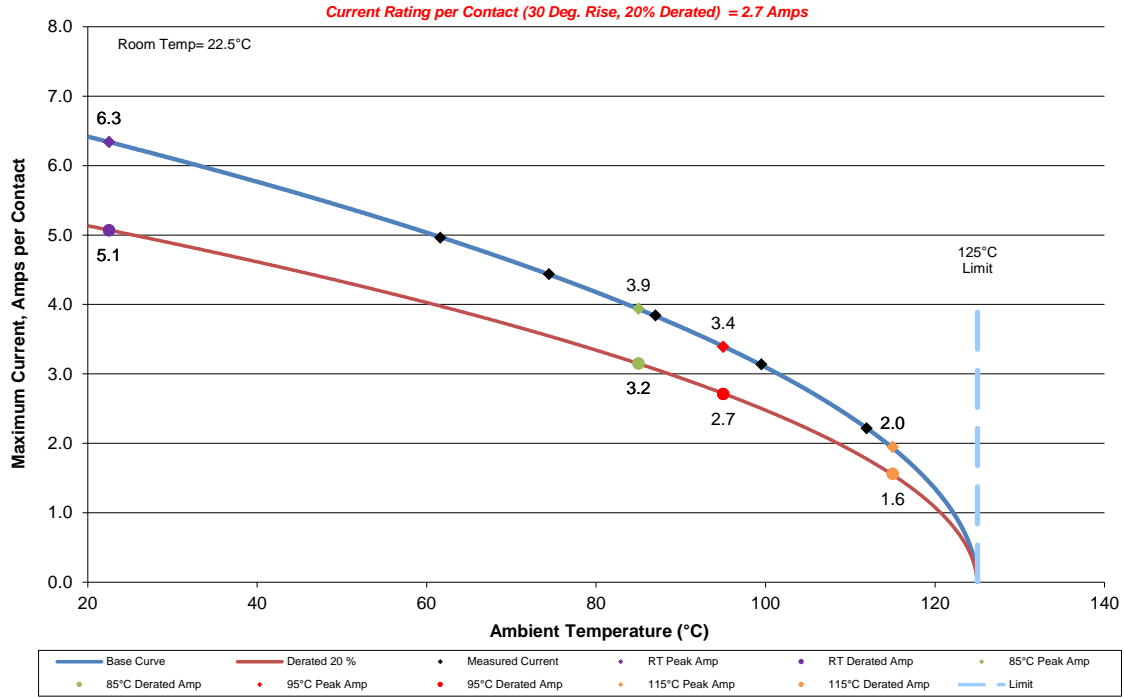

DATA SUMMARIES Continued

d. Linear configuration with 8 adjacent conductors/contacts powered.

CR-971602
 8 (2x4) Contacts in Series
 Part Numbers: B1SDT-30-28-H-12.0-2/P1PDT-30-28-H-12.0-B-2

Current Rating per Contact (30 Deg. Rise, 20% Derated) = 2.6 Amps

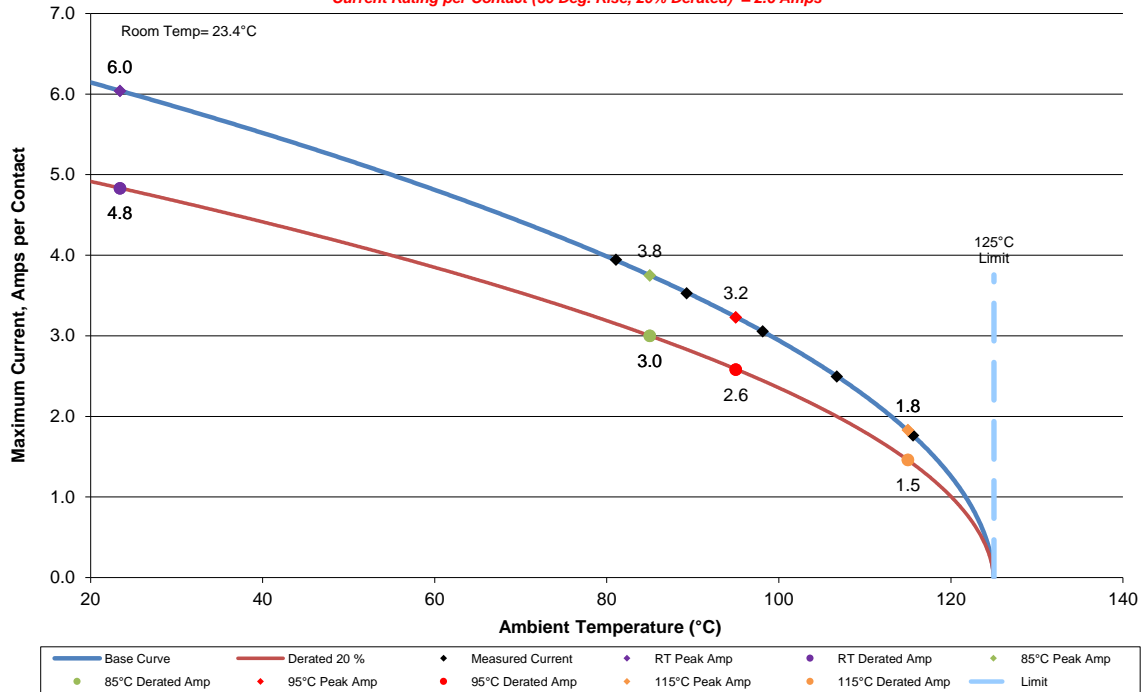

CR-971602
 8 (2x4) Contacts in Series
 Part Numbers: B1SDT-30-28-H-12.0-2/P1PDT-30-28-H-12.0-B-2

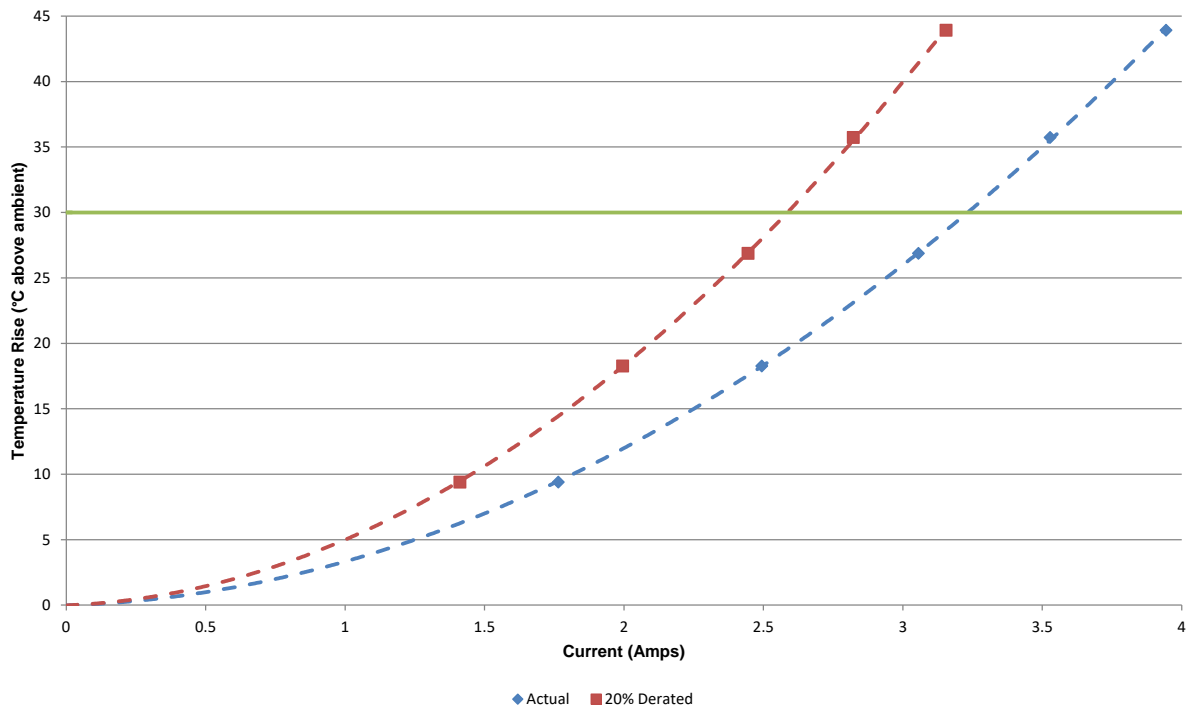

DATA SUMMARIES Continued

e. Linear configuration with All adjacent conductors/contacts powered.

CR-971602
60 (All Power) Contacts in Series
Part Numbers: B1SDT-30-28-H-12.0-2/P1PDT-30-28-H-12.0-B-2

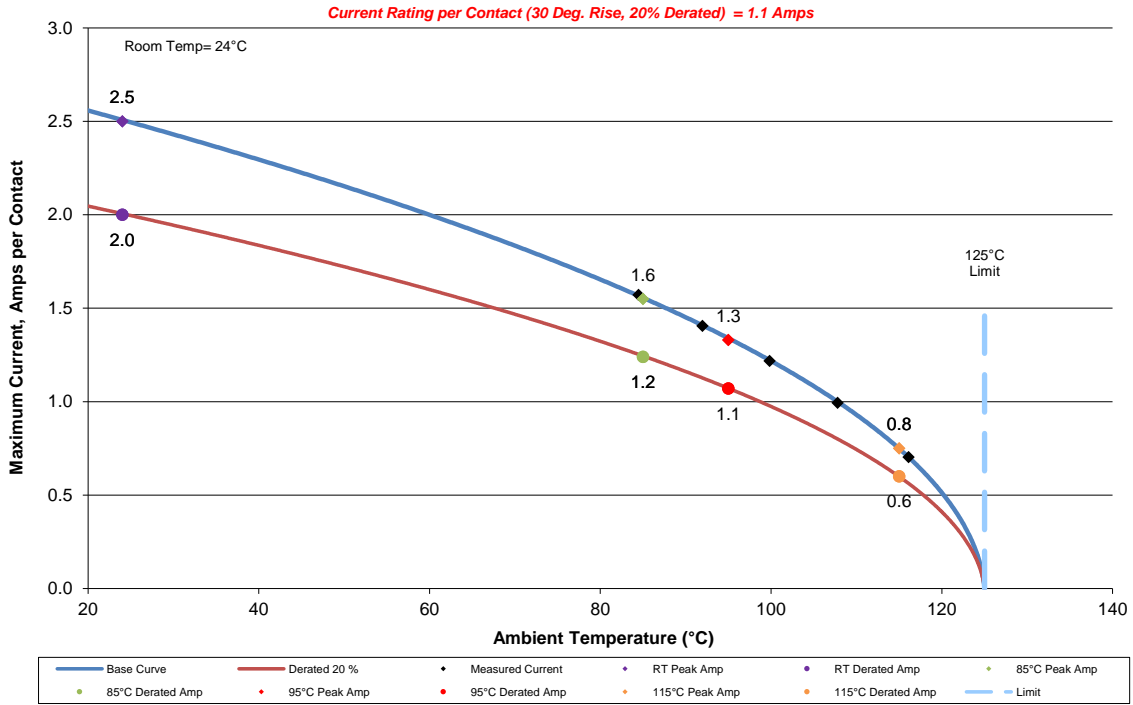

CR-971602
60 (All Power) Contacts in Series
Part Numbers: B1SDT-30-28-H-12.0-2/P1PDT-30-28-H-12.0-B-2

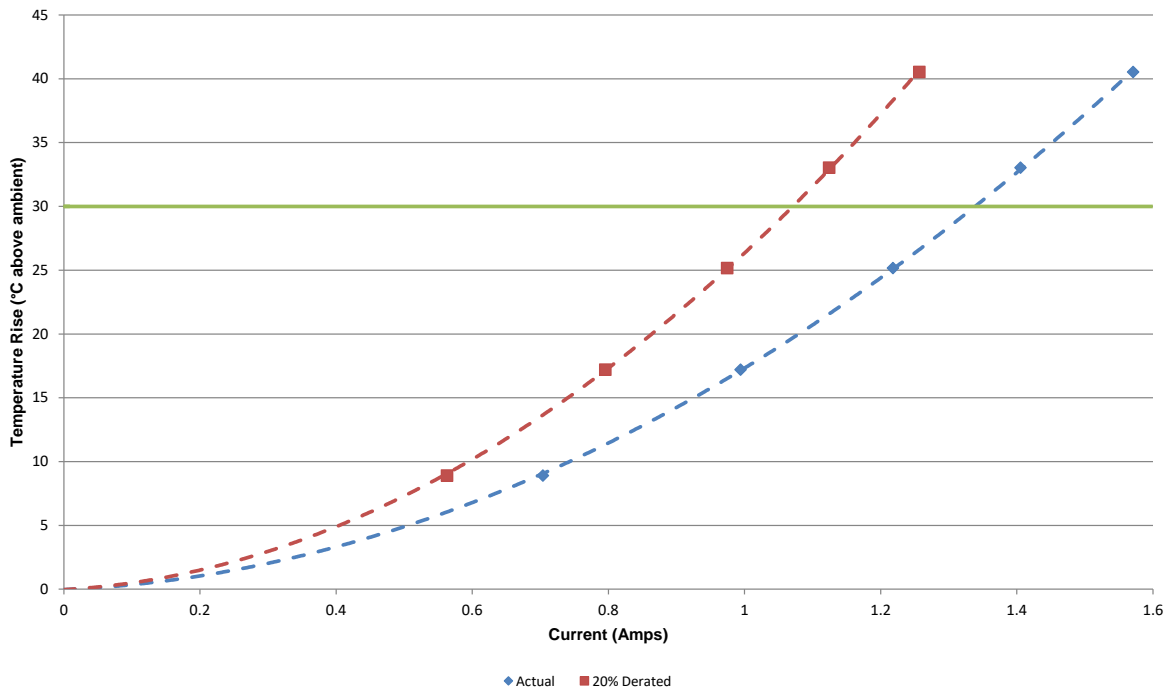

DATA SUMMARIES Continued

MATING/UNMATING:
Thermal Aging Group

	Initial				After Thermals			
	Mating		Unmating		Mating		Unmating	
	Newton's	Force (Lbs)	Newton's	Force (Lbs)	Newton's	Force (Lbs)	Newton's	Force (Lbs)
Minimum	44.08	9.91	39.23	8.82	22.95	5.16	34.29	7.71
Maximum	54.58	12.27	48.84	10.98	59.02	13.27	37.10	8.34
Average	51.06	11.48	43.73	9.83	37.56	8.44	36.09	8.11
St Dev	3.76	0.85	3.31	0.74	10.95	2.46	0.88	0.20
Count	8	8	8	8	8	8	8	8

Mating/Unmating Durability Group

	Initial				25 Cycles			
	Mating		Unmating		Mating		Unmating	
	Newton's	Force (Lbs)	Newton's	Force (Lbs)	Newton's	Force (Lbs)	Newton's	Force (Lbs)
Minimum	51.37	11.55	28.47	6.40	41.41	9.31	21.13	4.75
Maximum	58.18	13.08	54.35	12.22	47.59	10.70	41.99	9.44
Average	54.82	12.33	46.39	10.43	43.81	9.85	36.79	8.27
St Dev	2.39	0.54	7.94	1.78	1.90	0.43	6.58	1.48
Count	8	8	8	8	8	8	8	8

	50 Cycles				75 Cycles			
	Mating		Unmating		Mating		Unmating	
	Newton's	Force (Lbs)	Newton's	Force (Lbs)	Newton's	Force (Lbs)	Newton's	Force (Lbs)
Minimum	41.28	9.28	20.95	4.71	41.28	9.28	20.64	4.64
Maximum	47.37	10.65	38.88	8.74	47.68	10.72	39.54	8.89
Average	44.04	9.90	35.24	7.92	44.37	9.98	35.17	7.91
St Dev	1.97	0.44	5.98	1.34	2.05	0.46	6.06	1.36
Count	8	8	8	8	8	8	8	8

	100 Cycles				After Humidity			
	Mating		Unmating		Mating		Unmating	
	Newton's	Force (Lbs)	Newton's	Force (Lbs)	Newton's	Force (Lbs)	Newton's	Force (Lbs)
Minimum	41.63	9.36	20.59	4.63	36.16	8.13	32.92	7.40
Maximum	49.28	11.08	41.32	9.29	45.01	10.12	44.39	9.98
Average	45.23	10.17	35.72	8.03	39.86	8.96	38.16	8.58
St Dev	2.37	0.53	6.35	1.43	3.03	0.68	3.43	0.77
Count	8	8	8	8	8	8	8	8

DATA SUMMARIES Continued

Mating/Unmating Basic (B1SDT-10-28-H-06.0/ P1PDT-10-28-H-06.0)

	Initial				25 Cycles			
	Mating		Unmating		Mating		Unmating	
	Newton's	Force (Lbs)	Newton's	Force (Lbs)	Newton's	Force (Lbs)	Newton's	Force (Lbs)
Minimum	15.26	3.43	13.39	3.01	13.74	3.09	12.14	2.73
Maximum	19.39	4.36	17.21	3.87	17.66	3.97	14.23	3.20
Average	17.24	3.88	15.13	3.40	14.68	3.30	13.05	2.93
St Dev	1.60	0.36	1.24	0.28	1.31	0.29	0.76	0.17
Count	8	8	8	8	8	8	8	8
	50 Cycles				75 Cycles			
	Mating		Unmating		Mating		Unmating	
	Newton's	Force (Lbs)	Newton's	Force (Lbs)	Newton's	Force (Lbs)	Newton's	Force (Lbs)
Minimum	14.32	3.22	11.83	2.66	14.59	3.28	11.70	2.63
Maximum	18.33	4.12	13.61	3.06	17.17	3.86	13.48	3.03
Average	15.25	3.43	12.88	2.90	15.42	3.47	12.74	2.86
St Dev	1.28	0.29	0.57	0.13	0.79	0.18	0.54	0.12
Count	8	8	8	8	8	8	8	8
	100 Cycles							
	Mating		Unmating					
	Newton's	Force (Lbs)	Newton's	Force (Lbs)				
Minimum	15.03	3.38	11.92	2.68				
Maximum	17.61	3.96	13.52	3.04				
Average	15.89	3.57	12.82	2.88				
St Dev	0.80	0.18	0.50	0.11				
Count	8	8	8	8				

DATA SUMMARIES Continued

NORMAL FORCE (FOR CONTACTS TESTED OUTSIDE THE HOUSING):

- 1) Calibrated force gauges are used along with computer-controlled positioning equipment.
- 2) Typically, 8-10 readings are taken, and the averages reported.

After Thermals	Deflections in inches Forces in Grams										
	0.0002	0.0003	0.0005	0.0006	0.0008	0.0010	0.0011	0.0013	0.0014	0.0016	<i>SET</i>
Averages	13.49	26.11	32.71	45.26	58.09	64.60	77.58	84.68	96.91	104.18	0.0000
Min	9.50	23.00	29.40	39.70	51.20	56.70	70.20	76.40	88.50	98.00	0.0000
Max	16.60	30.40	36.70	51.90	64.30	71.20	82.60	92.10	104.90	110.40	0.0001
St. Dev	2.411	2.806	2.923	4.354	4.597	5.435	4.481	5.210	5.910	4.793	0.0001
Count	8	8	8	8	8	8	8	8	8	8	8

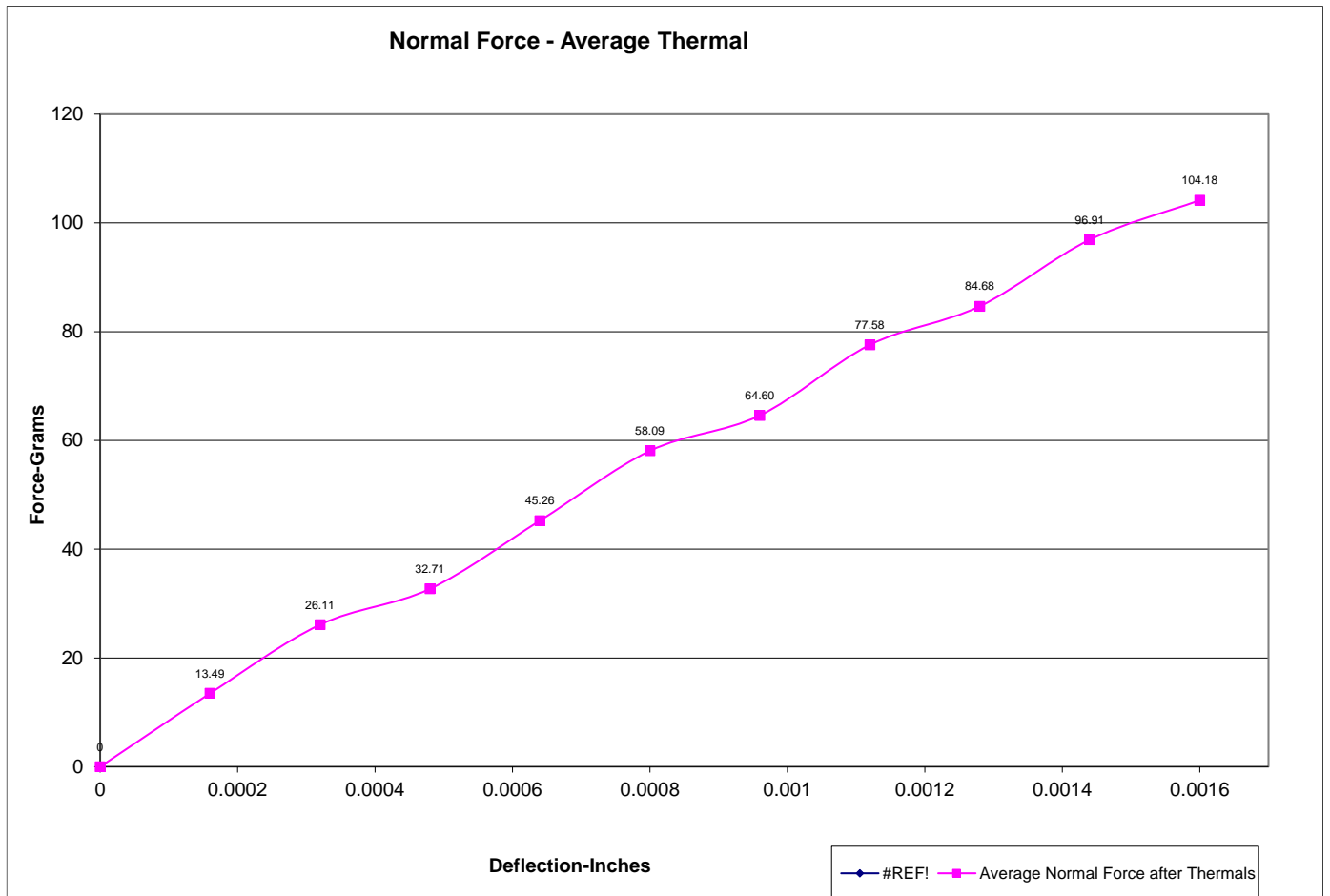

DATA SUMMARIES Continued

INSULATION RESISTANCE (IR):

	Pin to Pin		
	Mated	Unmated	Unmated
Minimum	B1SDT/P1PDT	B1SDT	P1PDT
Initial	45000	45000	45000
Thermal	45000	45000	45000
Humidity	45000	45000	45000

	Row to Row		
	Mated	Unmated	Unmated
Minimum	B1SDT/P1PDT	B1SDT	P1PDT
Initial	45000	45000	45000
Thermal	45000	45000	45000
Humidity	45000	45000	45000

DIELECTRIC WITHSTANDING VOLTAGE (DWV):

Voltage Rating Summary	
Minimum	B1SDT/P1PDT
Break Down Voltage	800
Test Voltage	600
Working Voltage	200

Row to Row	
Initial Test Voltage	Passed
After Thermal Test Voltage	Passed
After Humidity Test Voltage	Passed

Pin to Pin	
Initial Test Voltage	Passed
After Thermal Test Voltage	Passed
After Humidity Test Voltage	Passed

DATA SUMMARIES Continued

Cable Flex:

Insulation Resistance minimums, IR

Pin to Pin	
Mated	
Minimum	
Initial	45000
After 500 Flex Cycles	45000
Rotate Cable 90°	
After 500 Flex Cycles	45000
Row to Row	
Mated	
Minimum	
Initial	45000
After 500 Flex Cycles	45000
Rotate Cable 90°	
After 500 Flex Cycles	45000

Dielectric Withstanding Voltage minimums, DWV

Voltage Rating Summary	
Minimum	B1SDT/P1PDT
Break Down Voltage	800
Test Voltage	600
Working Voltage	200

Pin to Pin	
Initial Test Voltage	Passed
After 500 Flex Cycles Test Voltage	Passed
Rotate Cable 90°	
After 500 Flex Cycles Test Voltage	Passed

Row to Row	
Initial Test Voltage	Passed
After 500 Flex Cycles Test Voltage	Passed
Rotate Cable 90°	
After 500 Flex Cycles Test Voltage	Passed

DATA SUMMARIES Continued

**Cable Pull Force:
0° Pull**

	Force (lbs)
Minimum	32.31
Maximum	52.66
Average	42.75

90° Pull

	Force (lbs)
Minimum	19.52
Maximum	21.08
Average	20.19

DATA SUMMARIES Continued

LLCR Durability:

- 1) A total of 192 points were measured.
- 2) EIA-364-23, *Low Level Contact Resistance Test Procedure for Electrical Connectors and Sockets*.
- 3) A computer program, *LLCR 221.exe*, ensures repeatability for data acquisition.
- 4) The following guidelines are used to categorize the changes in LLCR as a result from stressing.
 - a. $\leq +5.0$ mOhms: -----Stable
 - b. $+5.1$ to $+10.0$ mOhms: -----Minor
 - c. $+10.1$ to $+15.0$ mOhms: -----Acceptable
 - d. $+15.1$ to $+50.0$ mOhms: -----Marginal
 - e. $+50.1$ to $+1000$ mOhms -----Unstable
 - f. $>+1000$ mOhms: -----Open Failure

LLCR Measurement Summaries by Pin Type				
Date	2023/9/29	2023/10/9	2023/10/16	2023/11/1
Room Temp (Deg C)	22	22	22	22
Rel Humidity (%)	52	38	41	29
Technician	Daniel Haydon	Daniel Haydon	Daniel Haydon	Daniel Haydon
mOhm values	Actual	Delta	Delta	Delta
	Initial	Cycles	Therm Shck	Humidity
Pin Type: Signal 1				
Average	62.81	1.03	0.97	1.14
St. Dev.	1.12	1.00	1.05	1.18
Min	60.36	0.00	0.00	0.00
Max	66.20	4.71	5.25	5.60
Summary Count	192	192	192	192
Total Count	192	192	192	192

LLCR Delta Count by Category						
	Stable	Minor	Acceptable	Marginal	Unstable	Open
mOhms	≤ 5	$>5 \ \& \ \leq 10$	$>10 \ \& \ \leq 15$	$>15 \ \& \ \leq 50$	$>50 \ \& \ \leq 1000$	>1000
Cycles	192	0	0	0	0	0
Therm Shck	190	2	0	0	0	0
Humidity	189	3	0	0	0	0

DATA SUMMARIES Continued

LLCR Thermal Aging:

- 1) A total of 192 points were measured.
- 2) EIA-364-23, *Low Level Contact Resistance Test Procedure for Electrical Connectors and Sockets*.
- 3) A computer program, *LLCR 221.exe*, ensures repeatability for data acquisition.
- 4) The following guidelines are used to categorize the changes in LLCR as a result from stressing.
 - a. $\leq +5.0$ mOhms: -----Stable
 - b. $+5.1$ to $+10.0$ mOhms:-----Minor
 - c. $+10.1$ to $+15.0$ mOhms: -----Acceptable
 - d. $+15.1$ to $+50.0$ mOhms: -----Marginal
 - e. $+50.1$ to $+1000$ mOhms: -----Unstable
 - f. $>+1000$ mOhms:-----Open Failure

LLCR Measurement Summaries by Pin Type			
Date	2023/10/2	2023/10/18	
Room Temp (Deg C)	22	22	
Rel Humidity (%)	50	40	
Technician	Daniel Haydon	Daniel Haydon	
mOhm values	Actual	Delta	
	Initial	Thermal	
Pin Type: Signal 1			
Average	62.22	0.64	
St. Dev.	1.26	0.83	
Min	60.24	0	
Max	68.15	4.53	
Summary Count	192	192	
Total Count	192	192	

LLCR Delta Count by Category						
	Stable	Minor	Acceptable	Marginal	Unstable	Open
mOhms	≤ 5	$>5 \ \& \ \leq 10$	$>10 \ \& \ \leq 15$	$>15 \ \& \ \leq 50$	$>50 \ \& \ \leq 1000$	>1000
Thermal	192	0	0	0	0	0

DATA SUMMARIES Continued

LLCR Gas Tight:

- 1) A total of 192 points were measured.
- 2) EIA-364-23, *Low Level Contact Resistance Test Procedure for Electrical Connectors and Sockets*.
- 3) A computer program, *LLCR 221.exe*, ensures repeatability for data acquisition.
- 4) The following guidelines are used to categorize the changes in LLCR as a result from stressing.
 - a. $\leq +5.0$ mOhms: -----Stable
 - b. $+5.1$ to $+10.0$ mOhms: -----Minor
 - c. $+10.1$ to $+15.0$ mOhms: -----Acceptable
 - d. $+15.1$ to $+50.0$ mOhms: -----Marginal
 - e. $+50.1$ to $+1000$ mOhms: -----Unstable
 - f. $>+1000$ mOhms: -----Open Failure

LLCR Measurement Summaries by Pin Type			
Date	2023/10/9	2023/10/10	
Room Temp (Deg C)	22	22	
Rel Humidity (%)	37	35	
Technician	Daniel Haydon	Daniel Haydon	
mOhm values	Actual	Delta	
	Initial	Acid Vapor	
Pin Type: Signal 1			
Average	62.7	1.31	
St. Dev.	1.2	0.6	
Min	60.66	0.11	
Max	70.65	4.32	
Summary Count	192	192	
Total Count	192	192	

LLCR Delta Count by Category						
	Stable	Minor	Acceptable	Marginal	Unstable	Open
mOhms	≤ 5	$>5 \ \& \ \leq 10$	$>10 \ \& \ \leq 15$	$>15 \ \& \ \leq 50$	$>50 \ \& \ \leq 1000$	>1000
Acid Vapor	192	0	0	0	0	0

DATA SUMMARIES Continued

LLCR Shock &Vibration:

- 1). A total of 192 points were measured.
- 2). EIA-364-23, *Low Level Contact Resistance Test Procedure for Electrical Connectors and Sockets.*
- 3). The following guidelines are used to categorize the changes in LLCR as a result from stressing.
 - a. $\leq +5.0$ mOhms: -----Stable
 - b. $+5.1$ to $+10.0$ mOhms: -----Minor
 - c. $+10.1$ to $+15.0$ mOhms: -----Acceptable
 - d. $+15.1$ to $+50.0$ mOhms: -----Marginal
 - e. $+50.1$ to $+1000$ mOhms -----Unstable
 - f. $>+1000$ mOhms:-----Open Failure

LLCR Measurement Summaries by Pin Type			
Date	2024/2/12	2024/2/15	
Room Temp (Deg C)	23	22	
Rel Humidity (%)	29	33	
Technician	Richard Ison	Richard Ison	
mOhm values	Actual	Delta	
	Initial	Shock-Vib	
Pin Type: Signal 1			
Average	126.1	0.65	
St. Dev.	1.69	0.77	
Min	121.71	0	
Max	131.79	5.53	
Summary Count	192	192	
Total Count	192	192	

LLCR Delta Count by Category						
	Stable	Minor	Acceptable	Marginal	Unstable	Open
mOhms	≤ 5	$>5 \ \& \ \leq 10$	$>10 \ \& \ \leq 15$	$>15 \ \& \ \leq 50$	$>50 \ \& \ \leq 1000$	>1000
Shock-Vib	191	1	0	0	0	0

Nanosecond Event Detection:

Shock and Vibration Event Detection Summary	
Contacts tested	60
Test Condition	C, 100g's, 6ms, Half-Sine
Shock Events	0
Test Condition	V-B, 7.56 rms g
Vibration Events	0
Total Events	0

EQUIPMENT AND CALIBRATION SCHEDULES

Equipment #: TCT-04

Description: Dillon Quantrol TC21 25-1000 mm/min series test stand

Manufacturer: Dillon Quantrol

Model: TC2 I series test stand

Serial #: 04-1041-04

Accuracy: Speed Accuracy: +/- 5% of indicated speed; Speed Accuracy: +/- 5% of indicated speed;
 ... Last Cal: 05/29/2023, Next Cal: 05/29/2024

Equipment #: MO-11

Description: Switch/Multimeter

Manufacturer: Keithley

Model: 3706

Serial #: 120169

Accuracy: See Manual

... Last Cal: 09/11/2023, Next Cal: 09/11/2024

Equipment #: TSC-01

Description: Vertical Thermal Shock Chamber

Manufacturer: Cincinnati Sub Zero

Model: VTS-3-6-6-SC/AC

Serial #: 10-VT14993

Accuracy: See Manual

... Last Cal: 06/30/2023, Next Cal: 06/30/2024

Equipment #: THC-05

Description: Temperature/Humidity Chamber (Chamber Room)

Manufacturer: Thermotron

Model: SM-8-3800

Serial #: 05 23 00 02

Accuracy: See Manual

... Last Cal: 11/14/2023, Next Cal: 11/14/2024

Equipment #: HPT-01

Description: Hipot Safety Tester

Manufacturer: Vitrek

Model: V73

Serial #: 019808

Accuracy:

... Last Cal: 05/15/2023, Next Cal: 05/15/2024

Equipment #: PS-02

Description: Power Supply

Manufacturer: Hewlett-Packer

Model: 6033A

Serial #: N/A

Accuracy: See Manual

... Last Cal: NOT CALIBRATED

EQUIPMENT AND CALIBRATION SCHEDULES

Equipment #: MO-04

Description: Multimeter /Data Acquisition System

Manufacturer: Keithley

Model: 2700

Serial #: 0798688

Accuracy: See Manual

... Last Cal: 09/11/2023, Next Cal: 09/11/2024

Equipment #: SVC-01

Description: Shock & Vibration Table

Manufacturer: Data Physics

Model: LE-DSA-10-20K

Serial #: 10037

Accuracy: See Manual

... Last Cal: 04/22/2023, Next Cal: 04/22/2024

Equipment #: ACLM-01

Description: Accelerometer

Manufacturer: PCB Piezotronics

Model: 352C03

Serial #: 115819

Accuracy: See Manual

... Last Cal: 07/18/2023, Next Cal: 07/18/2024

Equipment #: ED-03

Description: Event Detector

Manufacturer: Analysis Tech

Model: 32EHD

Serial #: 1100604

Accuracy: See Manual

... Last Cal: 10/31/2023, Next Cal: 10/31/2024