

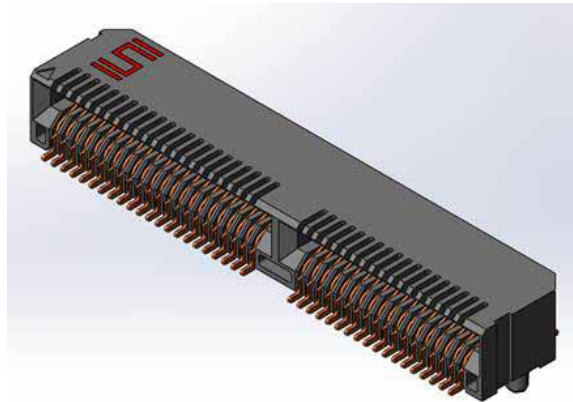

High Speed Characterization Report

MEC8-1XX-02-X-D-RA1



Description:
Mini Edge Card Right Angle Socket, 0.8mm Pitch,
Mates with 1.60mm thick cards

Series: MEC8-RA Series

Description: Mini Edge Card Right Angle, 0.8mm Pitch, mates to 1.6mm thick card

Table of Contents

Connector Overview	1
Connector System Speed Rating	1
Frequency Domain Data Summary	3
Table 1 - Single-Ended Connector System Performance	3
Table 2 - Differential Connector System Performance.....	3
Bandwidth Chart – Single-Ended & Differential Insertion Loss	4
Time Domain Data Summary	5
Table 3 - Single-Ended Impedance (Ω)	5
Table 4 - Differential Impedance (Ω).....	6
Table 5 - Single-Ended Crosstalk (%).....	7
Table 6 - Differential Crosstalk (%).....	7
Table 7 - Propagation Delay (Mated Connector)	7
Characterization Details	8
Differential and Single-Ended Data.....	8
Connector Signal to Ground Ratio	8
Frequency Domain Data	10
Time Domain Data	10
Appendix A – Frequency Domain Response Graphs	12
Single-Ended Application – Insertion Loss	12
Single-Ended Application – Return Loss	12
Single-Ended Application – NEXT Configurations	13
Single-Ended Application – FEXT Configurations	14
Differential Application – Insertion Loss	15
Differential Application – Return Loss.....	15
Differential Application – NEXT Configurations	16
Differential Application – FEXT Configurations	17
Appendix B – Time Domain Response Graphs	18
Single-Ended Application – Input Pulse	18
Single-Ended Application – Impedance	19
Single-Ended Application – Propagation Delay	20
Single-Ended Application – NEXT, Worst Case Configuration	21
Single-Ended Application – FEXT, Worst Case Configuration.....	22
Single-Ended Application – NEXT, Best Case Configuration	23
Single-Ended Application – FEXT, Best Case Configuration.....	24
Single-Ended Application – NEXT, Across Row Configuration	25
Single-Ended Application – FEXT, Across Row Configuration	25
Differential Application – Input Pulse	26
Differential Application – Impedance	27
Differential Application – Propagation Delay.....	28
Differential Application – NEXT, Worst Case Configuration.....	29

Series: MEC8-RA Series

Description: Mini Edge Card Right Angle, 0.8mm Pitch, mates to 1.6mm thick card

Differential Application – FEXT, Worst Case Configuration	30
Differential Application – NEXT, Best Case Configuration	31
Differential Application – FEXT, Best Case Configuration	32
Differential Application – NEXT, Across Row Case Configuration	33
Differential Application – FEXT, Across Row Case Configuration	33
Appendix C – Product and Test System Descriptions	34
Product Description	34
Test System Description	34
PCB-105901-SIG-XX Test Fixtures	34
PCB-105901-SIG-XX PCB Layout Panel	35
PCB Fixtures	35
Calibration Board	37
Appendix D – Test and Measurement Setup	39
N5230C Measurement Setup	39
Test Instruments	39
Test Cables & Adapters	39
DSA8200 Measurement Setup	40
Test Instruments	40
Test Cables & Adapters	40
Appendix E - Frequency and Time Domain Measurements	41
Frequency (S-Parameter) Domain Procedures	41
Time Domain Procedures	41
Propagation Delay (TDT)	41
Near-End Crosstalk (TDT) & Far End Crosstalk (TDT)	41
Impedance (TDR)	42

Series: MEC8-RA Series

Description: Mini Edge Card Right Angle, 0.8mm Pitch, mates to 1.6mm thick card

Connector Overview

The MEC8-RA series is a double row, mini edge-card socket connector on a 0.8mm (0.0315") pitch and available up to 100 pins. The data in this report is applicable to MEC8 right angle socket connector mated to 1.6mm (0.062") thick card.

MEC8-RA possesses two terminal types, with each terminal type having different performance. The signal integrity performance of these two terminal types is documented in this report. The terminology used to define which connector terminal is as follows:

*The short terminal of the connector is referred to as "Case 1"

*The long terminal of the connector is referred to as "Case 2"

This is illustrated in the following figure:

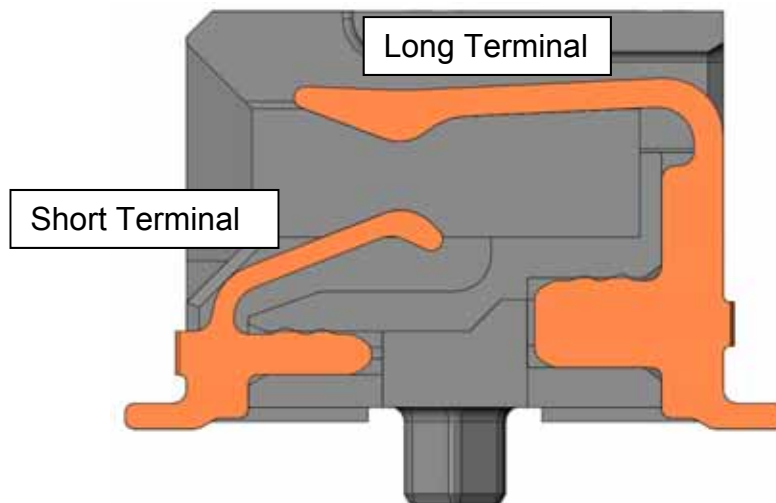

Connector System Speed Rating

MEC8-RA Mini Edge-Card Series, 0.8mm Pitch, mates to 1.6mm thick card

<u>Case</u>	<u>Signaling</u>	<u>Speed Rating</u>
1 (Short Row)	Single-Ended:	8.5 GHz/ 17 Gbps
	Differential:	9.5 GHz/ 19 Gbps
2 (Long Row)	Single-Ended:	8.5 GHz/ 17 Gbps
	Differential:	8 GHz/ 16 Gbps

Series: MEC8-RA Series

Description: Mini Edge Card Right Angle, 0.8mm Pitch, mates to 1.6mm thick card

The Speed Rating is based on the -3 dB insertion loss point of the connector system. The -3 dB point can be used to estimate usable system bandwidth in a typical, two-level signaling environment.

To calculate the Speed Rating, the measured -3 dB point is rounded-up to the nearest half-GHz level. The up rounding corrects for a portion of the test board's trace loss, since a short length of trace loss included in the loss data in this report. The resulting loss value is then doubled to determine the approximate maximum data rate in Gigabits per second (Gbps).

For example, a connector with a -3 dB point of 7.8 GHz would have a Speed Rating of 8 GHz/ 16 Gbps. A connector with a -3 dB point of 7.2 GHz would have a Speed Rating of 7.5 GHz/ 15 Gbps.

Series: MEC8-RA Series

Description: Mini Edge Card Right Angle, 0.8mm Pitch, mates to 1.6mm thick card

Frequency Domain Data Summary

Table 1 - Single-Ended Connector System Performance					
Case 1 = Short Row; Case 2 = Long Row					
Case	Test Parameter	Configuration	Driver	Receiver	
1	Insertion Loss	GSG	Edge_Card_61	MEC8-RA_61	3dB@ 8.04 GHz
	Return Loss	GSG	Edge_Card_61	Edge_Card_61	>10dB to 4.9 GHz
	Near-End Crosstalk	GAQQG	Edge_Card_21	Edge_Card_23	<-20dB to 1.4 GHz
		GAGQG	Edge_Card_61	Edge_Card_65	<-20dB to 7 GHz
		Xrow, GAG to GQG	Edge_Card_61	Edge_Card_62	<-20dB to 6.8 GHz
	Far-End Crosstalk	GAQQG	Edge_Card_21	MEC8-RA_23	<-20dB to 5.5 GHz
		GAGQG	Edge_Card_61	MEC8-RA_65	<-20dB to 6.3 GHz
Xrow, GAG to GQG		Edge_Card_62	MEC8-RA_61	<-20dB to 20 GHz	
2	Insertion Loss	GSG	Edge_Card_62	MEC8-RA_62	3dB@ 8.03 GHz
	Return Loss	GSG	Edge_Card_62	Edge_Card_62	>10dB to 5.5 GHz
	Near-End Crosstalk	GAQQG	Edge_Card_22	Edge_Card_24	<-20dB to 0.7 GHz
		GAGQG	Edge_Card_62	Edge_Card_66	<-20dB to 20 GHz
	Far-End Crosstalk	GAQQG	Edge_Card_22	MEC8-RA_24	<-20dB to 3.7 GHz
		GAGQG	Edge_Card_62	MEC8-RA_66	<-20dB to 9.4 GHz

Table 2 - Differential Connector System Performance					
Case 1 = Short Row; Case 2 = Long Row					
Case	Test Parameter	Configuration	Driver	Receiver	
1	Insertion Loss	GSSG	Edge_Card_27,29	MEC8-RA_27,29	3dB@ 9.3 GHz
	Return Loss	GSSG	Edge_Card_27,29	Edge_Card_27,29	>10dB to 2.5 GHz
	Near-End Crosstalk	GAAQQG	Edge_Card_27,29	Edge_Card_31,33	<-20dB to 14.9 GHz
		GAAGQQG	Edge_Card_27,29	Edge_Card_33,35	<-20dB to 20 GHz
		Xrow, GAAG to GQQG	Edge_Card_21,23	Edge_Card_22,24	<-20dB to 20 GHz
	Far-End Crosstalk	GAAQQG	Edge_Card_27,29	MEC8-RA_31,33	<-20dB to 20 GHz
		GAAGQQG	Edge_Card_27,29	MEC8-RA_33,35	<-20dB to 20 GHz
Xrow, GAAG to GQQG		Edge_Card_22,24	MEC8-RA_21,23	<-20dB to 20 GHz	
2	Insertion Loss	GSSG	Edge_Card_28,30	MEC8-RA_28,30	3dB@ 7.7 GHz
	Return Loss	GSSG	Edge_Card_28,30	Edge_Card_28,30	>10dB to 1.4 GHz
	Near-End Crosstalk	GAAQQG	Edge_Card_28,30	Edge_Card_32,34	<-20dB to 14.8 GHz
		GAAGQQG	Edge_Card_28,30	Edge_Card_34,36	<-20dB to 20 GHz
	Far-End Crosstalk	GAAQQG	Edge_Card_28,30	MEC8-RA_32,34	<-20dB to 20 GHz
		GAAGQQG	Edge_Card_28,30	MEC8-RA_34,36	<-20dB to 20 GHz

Series: MEC8-RA Series

Description: Mini Edge Card Right Angle, 0.8mm Pitch, mates to 1.6mm thick card

Bandwidth Chart – Single-Ended & Differential Insertion Loss

Case 1 = Short Row; Case 2 = Long Row

MEC8-RA Connector Series

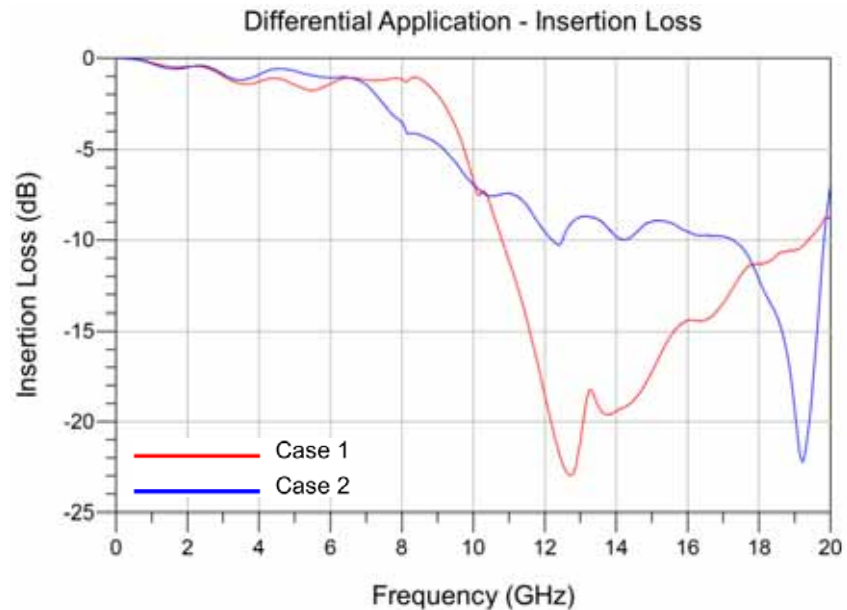
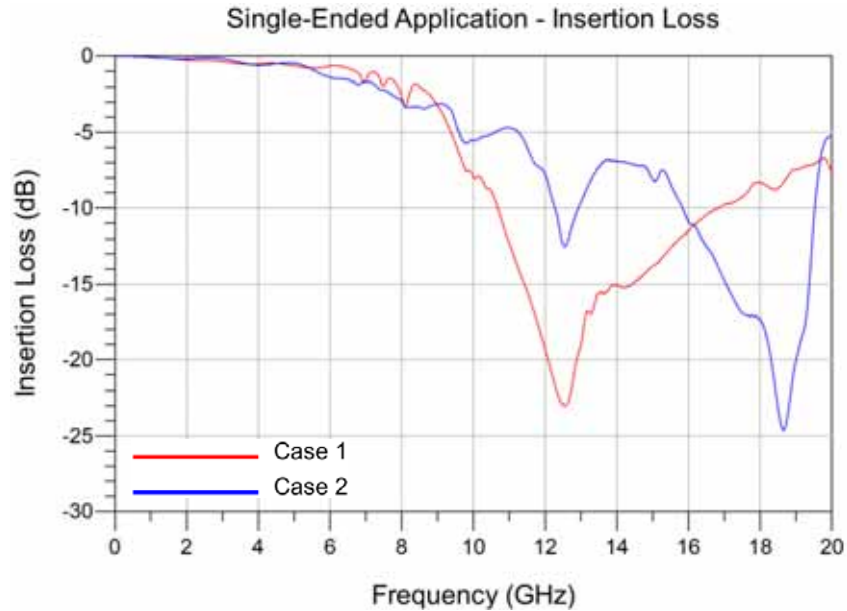

Series: MEC8-RA Series

Description: Mini Edge Card Right Angle, 0.8mm Pitch, mates to 1.6mm thick card

Time Domain Data Summary

Table 3 - Single-Ended Impedance (Ω)						
Case 1 = Short Row; Case 2 = Long Row						
Case	Signal Rise-time	30ps	50ps	100ps	250ps	500ps
1	Maximum Impedance	53.79	53.76	53.71	53.55	51.93
	Minimum Impedance	37.17	39.44	42.89	47.25	49.44
2	Maximum Impedance	58.35	55.33	53.03	53.01	52.16
	Minimum Impedance	41.70	42.66	46.22	49.57	50.96

Single-Ended Impedance - Case 1, Short Row

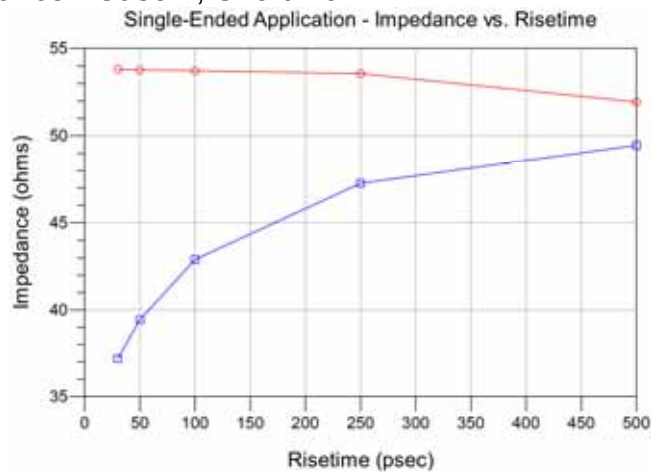

Single-Ended Impedance - Case 2, Long Row

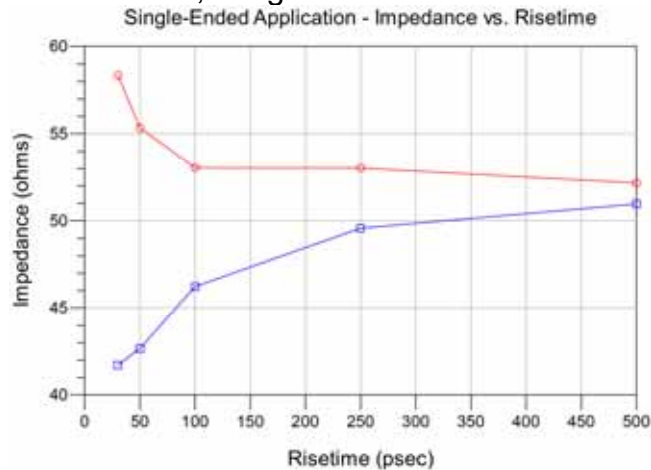

Series: MEC8-RA Series

Description: Mini Edge Card Right Angle, 0.8mm Pitch, mates to 1.6mm thick card

Table 4 - Differential Impedance (Ω)						
Case 1 = Short Row; Case 2 = Long Row						
Case	Signal Rise-time	30ps	50ps	100ps	250ps	500ps
1	Maximum Impedance	106.68	106.32	106.00	105.66	102.88
	Minimum Impedance	63.27	67.72	75.76	89.21	96.61
2	Maximum Impedance	107.70	107.62	107.46	106.91	103.86
	Minimum Impedance	68.65	70.99	78.29	88.99	96.54

Differential Impedance - Case 1, Short Row

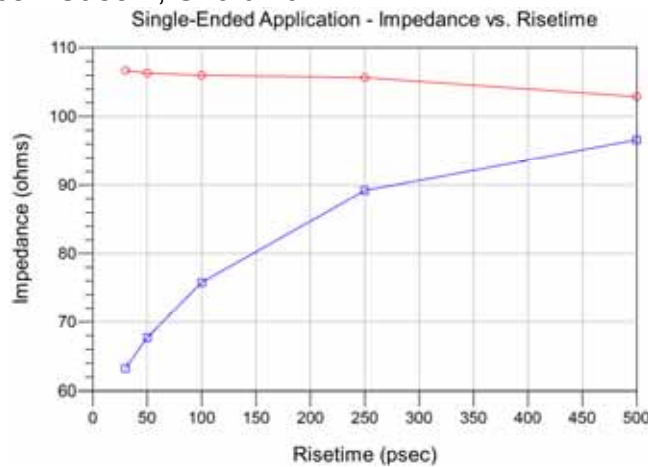

Differential Impedance - Case 2, Long Row

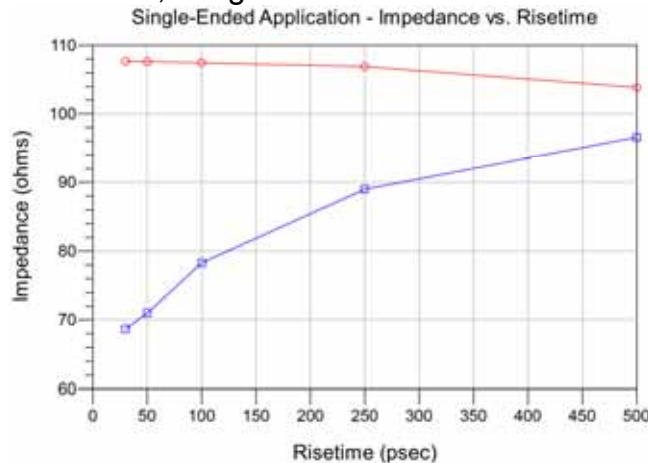



Series: MEC8-RA Series

Description: Mini Edge Card Right Angle, 0.8mm Pitch, mates to 1.6mm thick card

Table 5 - Single-Ended Crosstalk (%)
Case 1 = Short Row; Case 2 = Long Row

Case	Input(tr)	Configuration	Driver	Receiver	30ps	50ps	100ps	250ps	500ps
1	NEXT	GAQG	Edge_Card_21	Edge_Card_23	19.75	14.62	11.13	5.00	2.59
		GAGQG	Edge_Card_61	Edge_Card_65	3.80	3.01	1.96	0.82	0.41
		Xrow	Edge_Card_61	Edge_Card_62	2.16	1.81	1.29	0.57	0.27
	FEXT	GAQG	Edge_Card_21	MEC8-RA_23	5.15	4.16	2.22	0.66	0.23
		GAGQG	Edge_Card_61	MEC8-RA_65	3.45	2.49	1.29	0.47	0.27
		Xrow	Edge_Card_62	MEC8-RA_61	1.47	1.30	0.78	0.34	0.17
2	NEXT	GAQG	Edge_Card_22	Edge_Card_24	21.07	19.81	17.24	9.25	4.93
		GAGQG	Edge_Card_62	Edge_Card_66	3.03	2.79	2.13	1.17	0.53
	FEXT	GAQG	Edge_Card_22	MEC8-RA_24	6.39	4.11	2.46	0.86	0.39
		GAGQG	Edge_Card_62	MEC8-RA_66	3.32	2.40	1.28	0.52	0.20

Table 6 - Differential Crosstalk (%)
Case 1 = Short Row; Case 2 = Long Row

Case	Input(tr)	Configuration	Driver	Receiver	30ps	50ps	100ps	250ps	500ps
1	NEXT	GAAQQG	Edge_Card_27,29	Edge_Card_31,33	4.33	3.43	2.67	1.49	0.71
		GAAGQQG	Edge_Card_27,29	Edge_Card_33,35	0.52	0.30	0.16	0.10	<0.1
		Xrow	Edge_Card_21,23	Edge_Card_22,24	0.49	0.44	0.31	0.16	<0.1
	FEXT	GAAQQG	Edge_Card_27,29	MEC8-RA_31,33	2.17	1.91	1.46	0.81	0.44
		GAAGQQG	Edge_Card_27,29	MEC8-RA_33,35	0.33	0.24	0.13	<0.1	<0.1
		Xrow	Edge_Card_22,24	MEC8-RA_21,23	0.56	0.47	0.29	0.14	<0.1
2	NEXT	GAAQQG	Edge_Card_28,30	Edge_Card_32,34	5.84	5.18	4.58	2.72	1.47
		GAAGQQG	Edge_Card_28,30	Edge_Card_34,36	0.58	0.46	0.31	0.16	<0.1
	FEXT	GAAQQG	Edge_Card_28,30	MEC8-RA_32,34	1.93	1.43	1.17	0.73	0.39
		GAAGQQG	Edge_Card_28,30	MEC8-RA_34,36	0.40	0.30	0.16	<0.1	<0.1

Table 7 - Propagation Delay (Mated Connector)
Case 1 = Short Row; Case 2 = Long Row

Case 1	Single-Ended	30 ps
	Differential	25 ps
Case 2	Single-Ended	65 ps
	Differential	60 ps

Series: MEC8-RA Series

Description: Mini Edge Card Right Angle, 0.8mm Pitch, mates to 1.6mm thick card

Characterization Details

This report presents data that characterizes the signal integrity response of a connector pair in a controlled printed circuit board (PCB) environment. All efforts are made to reveal typical best-case responses inherent to the system under test (SUT).

In this report, the SUT includes the connector pair and footprint effects on a typical multi-layer PCB. PCB effects (trace loss) are de-embedded from test data. Board related effects, such as pad-to-ground capacitance, are included in the data presented in this report.

Additionally, intermediate test signal connections can mask the connector's true performance. Such connection effects are minimized by using high performance test cables and adapters. Where appropriate, calibration and de-embedding routines are also used to reduce residual effects.

Differential and Single-Ended Data

Most Samtec connectors can be used successfully in both differential and single-ended applications. However, electrical performance will differ depending on the signal drive type. In this report, data is presented for both differentially and single-ended driven scenarios.

Connector Signal to Ground Ratio

Samtec connectors are most often designed for generic applications and can be implemented using various signal and ground pin assignments. In high-speed systems, provisions must be made in the interconnect for signal return currents. Such paths are often referred to as "ground". In some connectors, a ground plane or blade, or an outer shield, is used as the signal return, while in others, connector pins are used as signal returns. Various combinations of signal pins, ground blades, and shields can also be utilized. Electrical performance can vary significantly depending upon the number and location of ground pins.

In general, the more pins dedicated to ground, the better electrical performance will be. However, dedicating pins to ground reduces signal density of a connector. Therefore, care must be taken when choosing signal/ground ratios in cost or density-sensitive applications.

Series: MEC8-RA Series

Description: Mini Edge Card Right Angle, 0.8mm Pitch, mates to 1.6mm thick card

For this connector, the following configurations were evaluated:

Single-Ended Impedance:

- GSG (Ground-Signal-Ground)

Single-Ended Crosstalk:

- Electrical “worst case”: GAQG (Ground-Active-Quiet-Ground)
- Electrical “best case”: GAGQG (Ground-Active-Ground-Quiet-Ground)
- Across row: “xrow case”: GAG to GQG (from one row of terminals to the other row)

Differential Impedance:

- GSSG (Ground-positive Signal-negative Signal-Ground)

Differential Crosstalk:

- Electrical “worst case”: GAAQQG (Ground-Active-Active-Quiet-Quiet-Ground)
- Electrical “best case”: GAAGQQG (Ground-Active-Active-Ground-Quiet-Quiet-Ground)
- Across row: “xrow case”: GAAG to GQQG (from one row of terminals to the other row)

Only one single-ended signal or differential pair was driven for crosstalk measurements.

Other configurations can be evaluated upon request. Please contact sig@samtec.com for more information.

In a real system environment, active signals might be located at the outer edges of the signal contacts of concern, as opposed to the ground signals utilized in laboratory testing. For example, in a single-ended system, a pin-out of “SSSS”, or four adjacent single ended signals might be encountered as opposed to the “GSG” and “GSSG” configurations tested in the laboratory. Electrical characteristics in such applications could vary slightly from laboratory results. However, in most applications, performance can safely be considered equivalent.

Signal Edge Speed (Rise Time):

In pulse signaling applications, the perceived performance of the interconnect can vary significantly depending on the edge rate or rise time of the exciting signal. For this report, the fastest rise time used was 30 ps. Generally, this should demonstrate worst-case performance.

Series: MEC8-RA Series

Description: Mini Edge Card Right Angle, 0.8mm Pitch, mates to 1.6mm thick card

In many systems, the signal edge rate will be significantly slower at the connector than at the driver launch point. To estimate interconnect performance at other edge rates, data is provided for several rise times between 30ps and 500ps.

For this report, measured rise times were at 10%-90% signal levels.

Frequency Domain Data

Frequency Domain parameters are helpful in evaluating the connector system's signal loss and crosstalk characteristics across a range of sinusoidal frequencies. In this report, parameters presented in the Frequency Domain are Insertion Loss, Return Loss, and Near-End and Far-End Crosstalk. Other parameters or formats, such as VSWR or S-Parameters, may be available upon request. Please contact our Signal Integrity Group at sig@samtec.com for more information.

Frequency performance characteristics for the SUT are generated directly from network analyzer measurements.

Time Domain Data

Time Domain parameters indicate Impedance mismatch versus length, signal propagation time and crosstalk in a pulsed signal environment.

Impedance mismatch versus length is measured by DSA8200 Digital Serial Analyzer. Board related effects, such as pad-to-ground capacitance and trace loss, are included in the data presented in this report. The impedance data is provided in [Appendix E](#) of this report.

The measured S-Parameters from the network analyzer are post-processed using Agilent Advanced Design System to obtain the time domain response for signal propagation time and crosstalk. The Time Domain procedure is provided in [Appendix E](#) of this report. Parameters or formats not included in this report may be available upon request. Please contact our Signal Integrity Group at sig@samtec.com for more information.

In this report, propagation delay is defined as the signal propagation time through the connector and connector footprint. It includes 10 mils of PCB trace on the MEC8-RA connector and the edge-card side each. Delay is measured at 100 picoseconds signal risetime. Delay is calculated as the difference in time measured between the 50% amplitude levels of the input and output pulses.

Crosstalk or coupled noise data is provided for various signal configurations. All measurements are single disturber. Crosstalk is calculated as a ratio of the input line voltage to the coupled line voltage. The input line is sometimes described as the active or drive

Series: MEC8-RA Series

Description: Mini Edge Card Right Angle, 0.8mm Pitch, mates to 1.6mm thick card

line. The coupled line is sometimes described as the quiet or victim line. Crosstalk ratio is tabulated in this report as a percentage. Measurements are made at both the near-end and far-end of the SUT.

Data for other configurations may be available. Please contact our Signal Integrity Group at sig@samtec.com for further information.

As a rule of thumb, 10% crosstalk levels are often used as a general first pass limit for determining acceptable interconnect performance. However, modern system crosstalk tolerance can vary greatly. For advice on connector suitability for specific applications, please contact our Signal Integrity Group at sig@samtec.com.

Additional information concerning test conditions and procedures is located in the appendices of this report. Further information may be obtained by contacting our Signal Integrity Group at sig@samtec.com.

Series: MEC8-RA Series

Description: Mini Edge Card Right Angle, 0.8mm Pitch, mates to 1.6mm thick card

Appendix A – Frequency Domain Response Graphs

Single-Ended Application – Insertion Loss

Case 1 = Short Row; Case 2 = Long Row

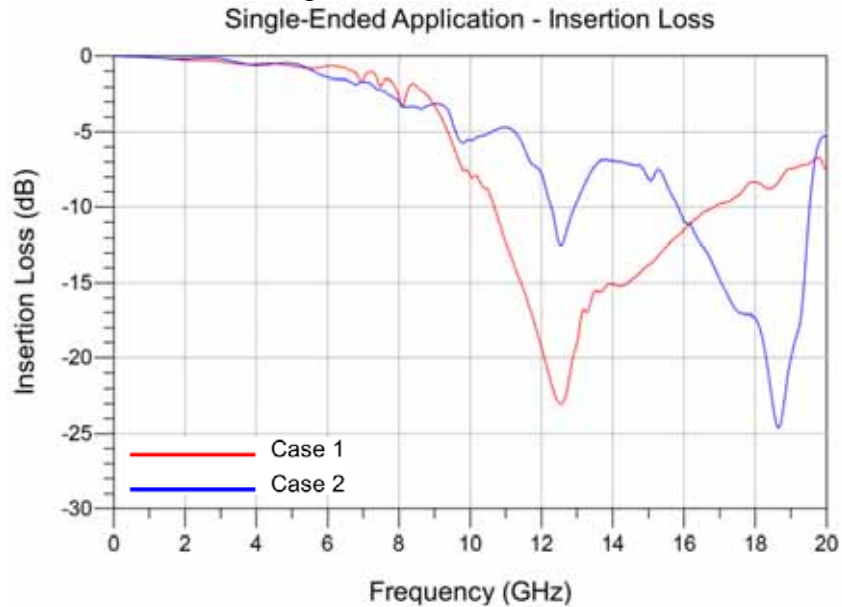

Single-Ended Application – Return Loss

Case 1 = Short Row; Case 2 = Long Row

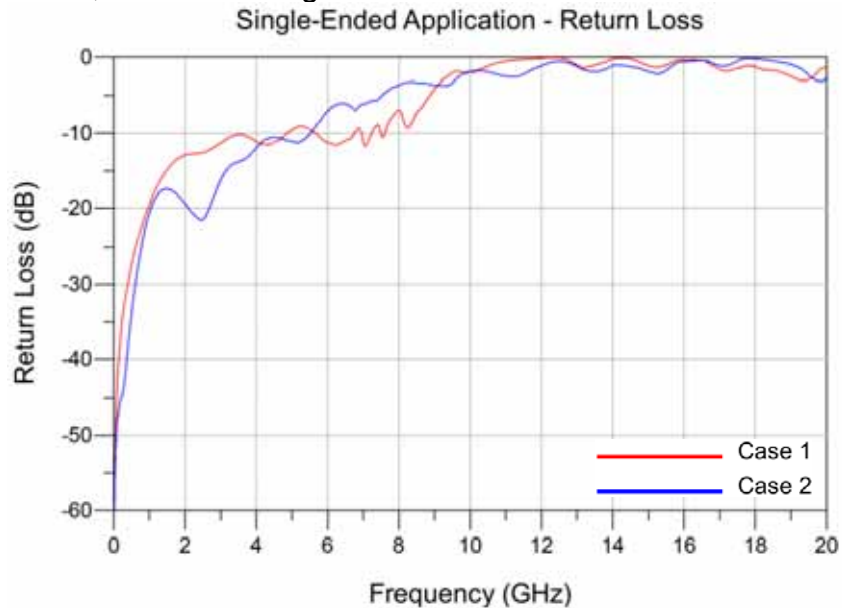

Series: MEC8-RA Series

Description: Mini Edge Card Right Angle, 0.8mm Pitch, mates to 1.6mm thick card

Single-Ended Application – NEXT Configurations

Case 1 (Short Row)

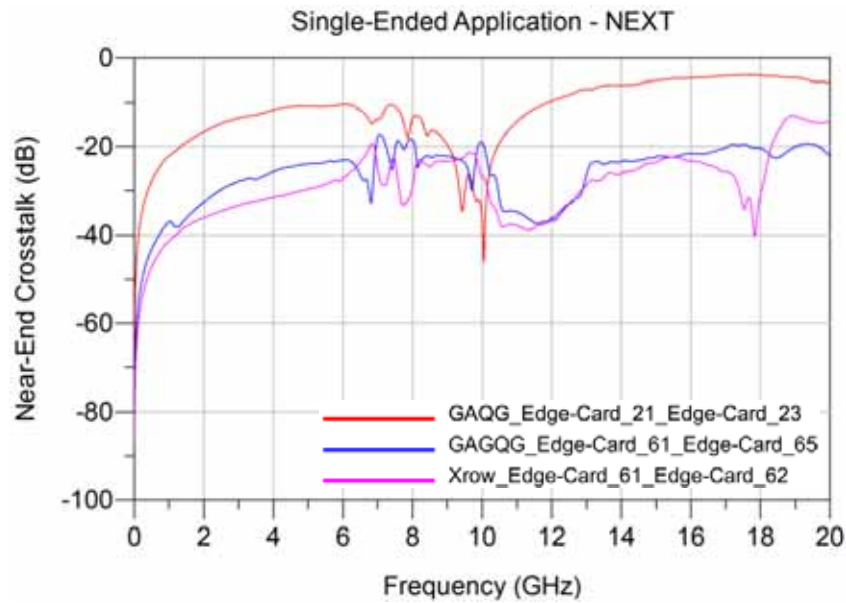

Case 2 (Long Row)

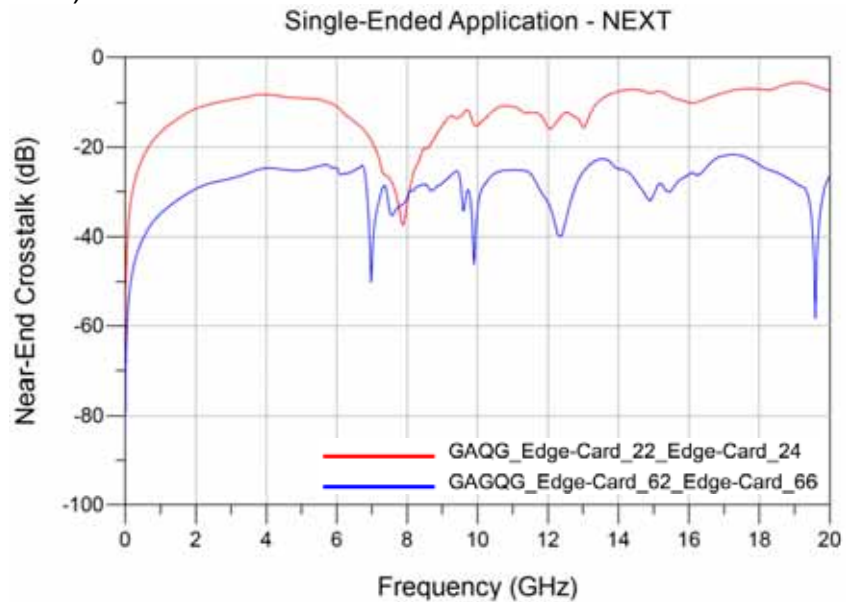

Series: MEC8-RA Series

Description: Mini Edge Card Right Angle, 0.8mm Pitch, mates to 1.6mm thick card

Single-Ended Application – FEXT Configurations

Case 1 (Short Row)

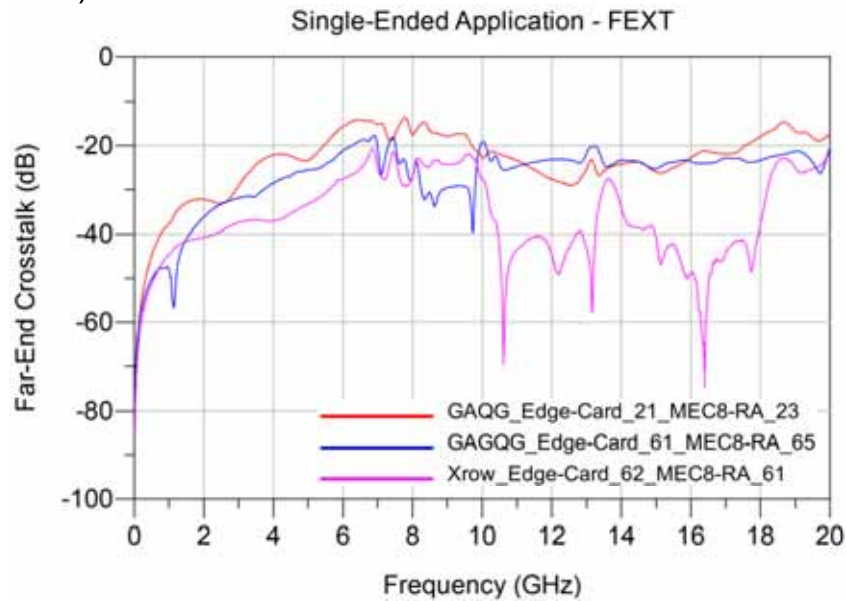

Case 2 (Long Row)

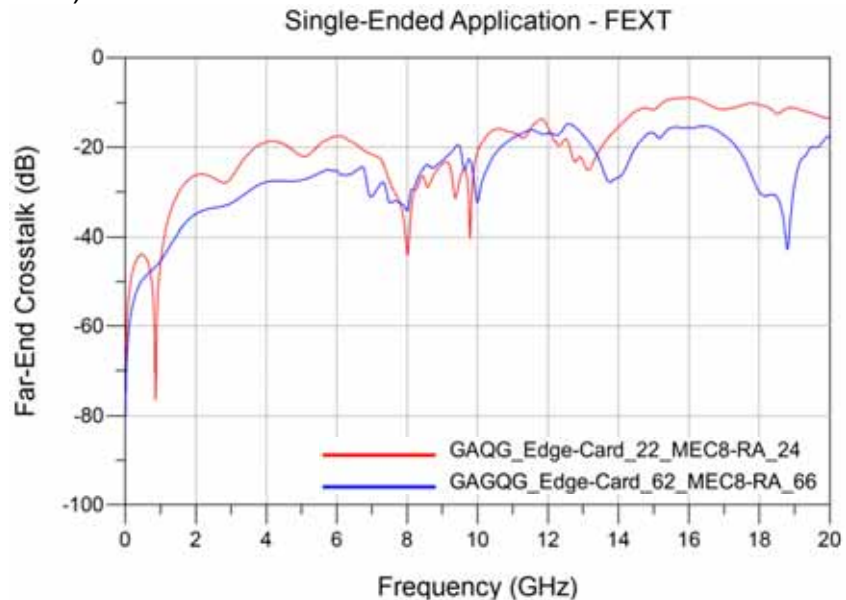

Series: MEC8-RA Series

Description: Mini Edge Card Right Angle, 0.8mm Pitch, mates to 1.6mm thick card

Differential Application – Insertion Loss

Case 1 = Short Row; Case 2 = Long Row

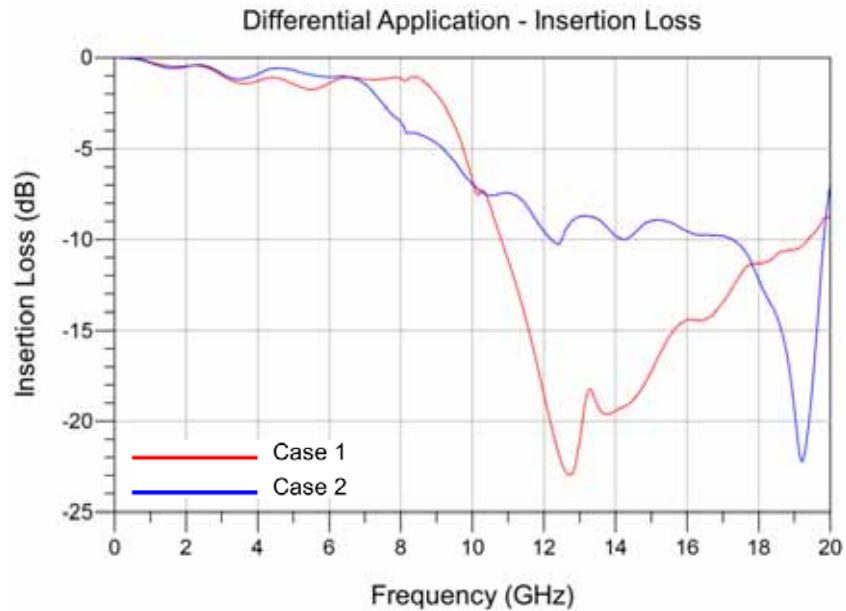

Differential Application – Return Loss

Case 1 = Short Row; Case 2 = Long Row

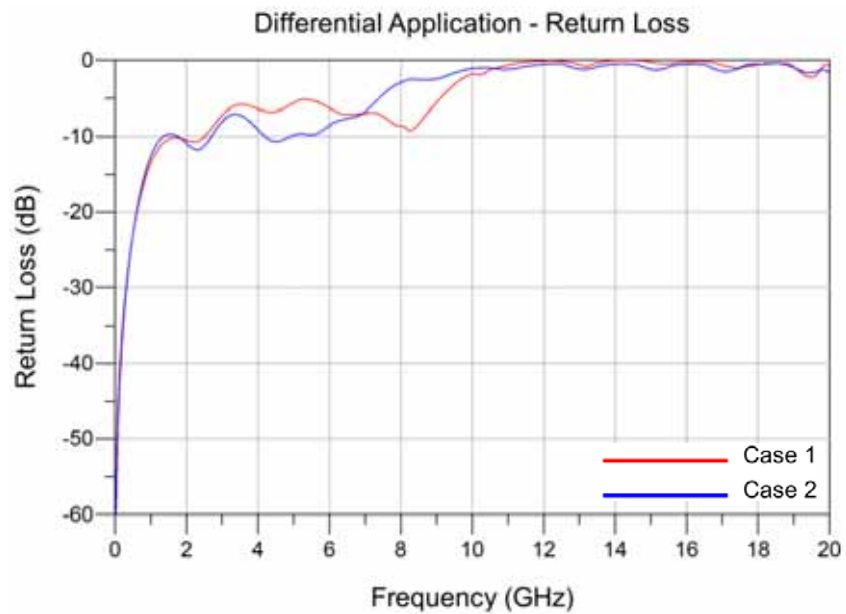

Series: MEC8-RA Series

Description: Mini Edge Card Right Angle, 0.8mm Pitch, mates to 1.6mm thick card

Differential Application – NEXT Configurations

Case 1 (Short Row)

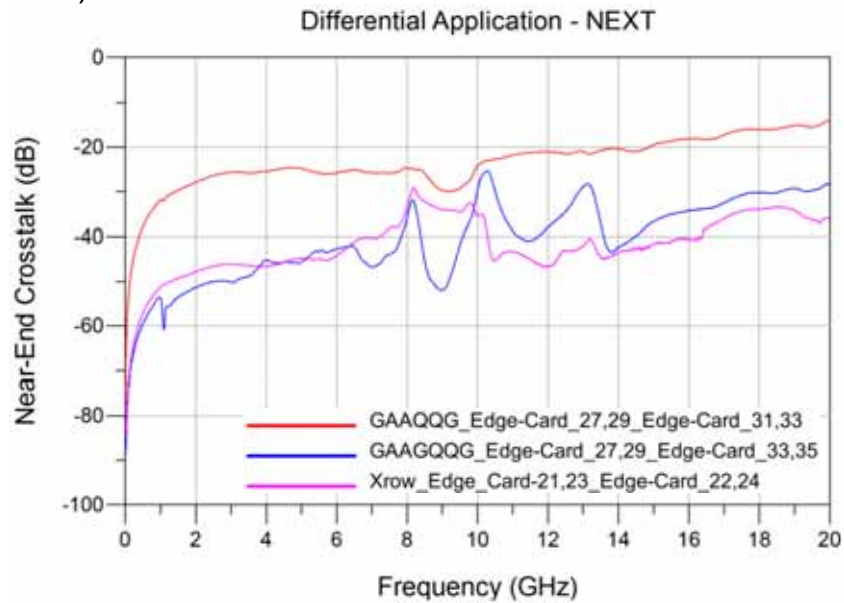

Case 2 (Long Row)

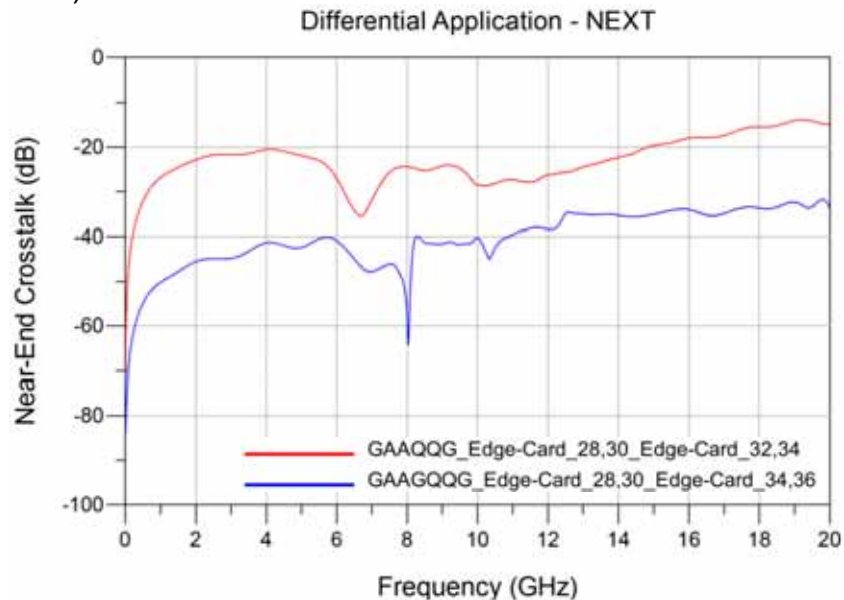

Series: MEC8-RA Series

Description: Mini Edge Card Right Angle, 0.8mm Pitch, mates to 1.6mm thick card

Differential Application – FEXT Configurations

Case 1 (Short Row)

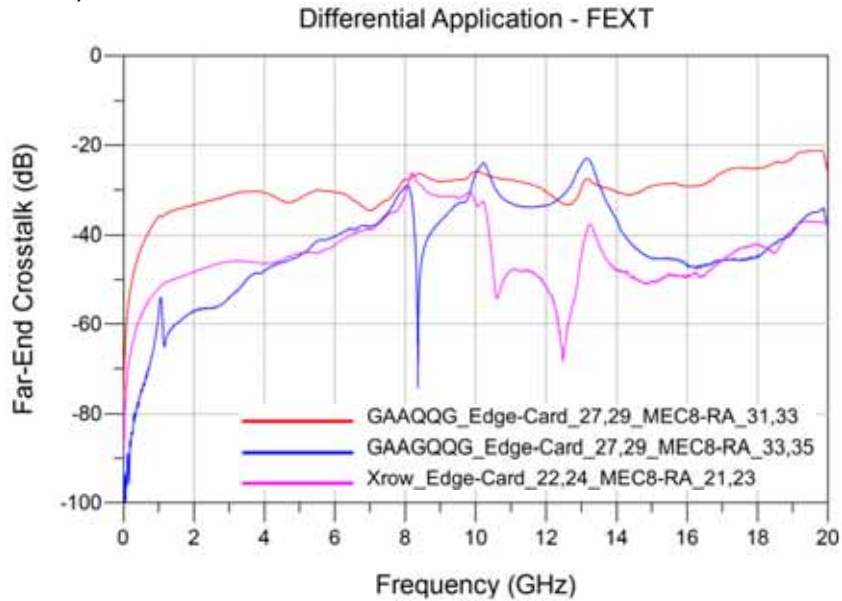

Case 2 (Long Row)

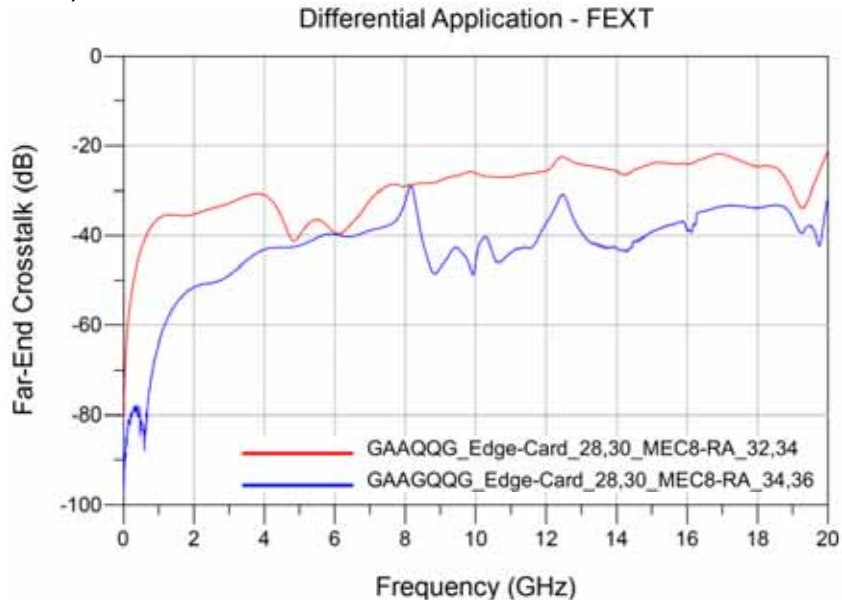

Series: MEC8-RA Series

Description: Mini Edge Card Right Angle, 0.8mm Pitch, mates to 1.6mm thick card

Appendix B – Time Domain Response Graphs

Single-Ended Application – Input Pulse

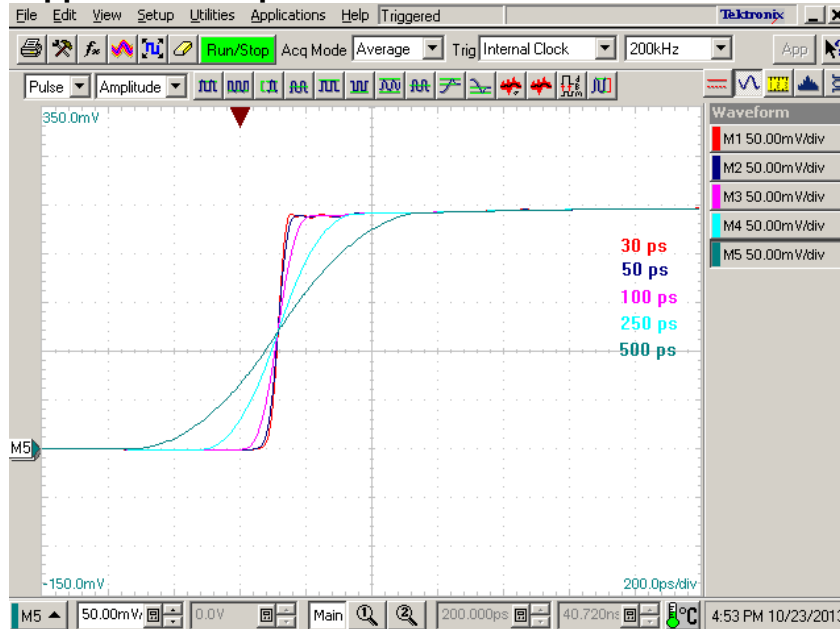

Series: MEC8-RA Series

Description: Mini Edge Card Right Angle, 0.8mm Pitch, mates to 1.6mm thick card

Single-Ended Application – Impedance

Case 1 (Short Row)



Case 2 (Long Row)

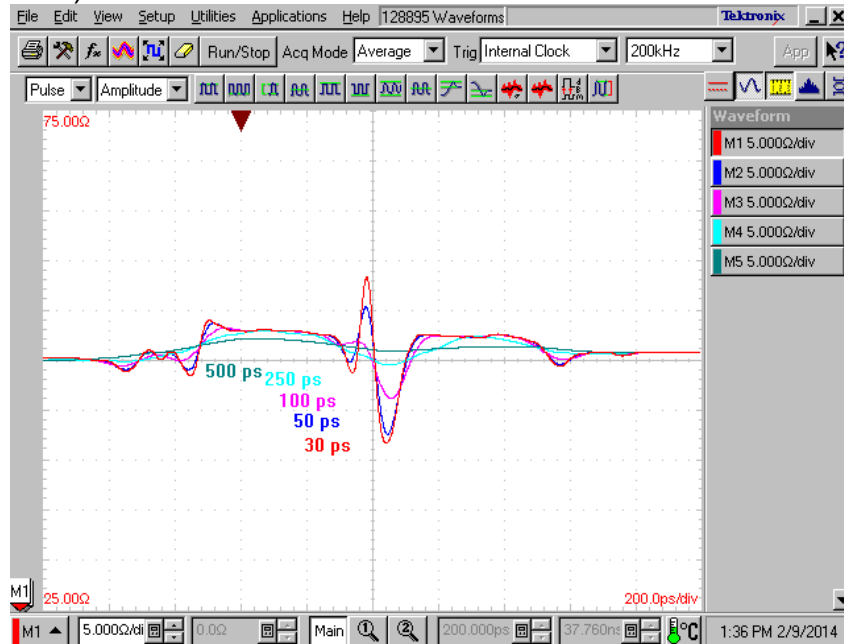

Series: MEC8-RA Series

Description: Mini Edge Card Right Angle, 0.8mm Pitch, mates to 1.6mm thick card

Single-Ended Application – Propagation Delay

Case 1 (Short Row)

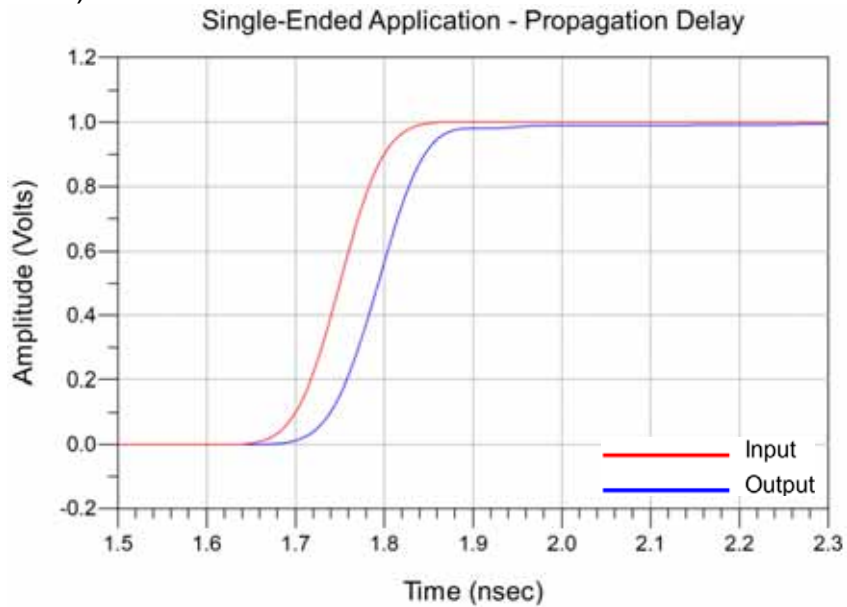

Case 2 (Long Row)

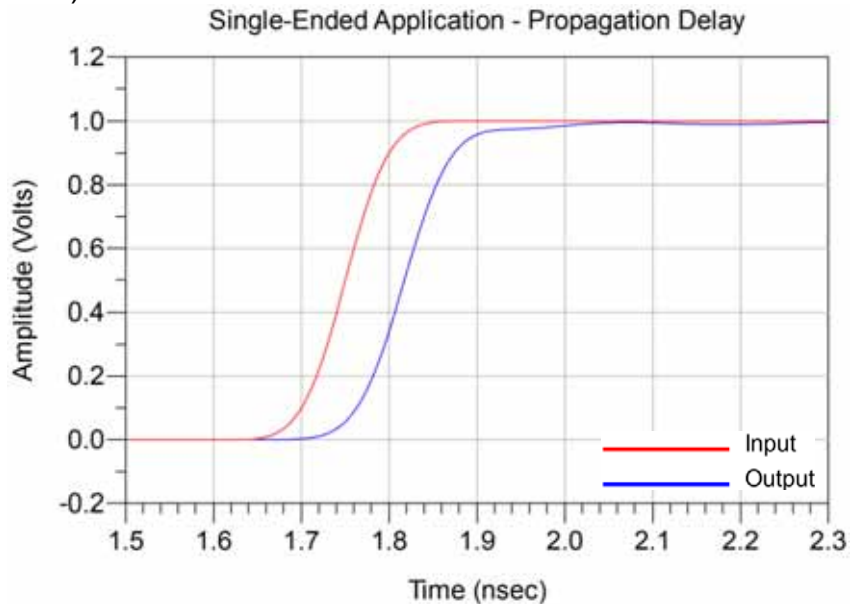

Series: MEC8-RA Series

Description: Mini Edge Card Right Angle, 0.8mm Pitch, mates to 1.6mm thick card

Single-Ended Application – NEXT, Worst Case Configuration

Case 1 (Short Row) - Edge-Card_21_Edge-Card_23

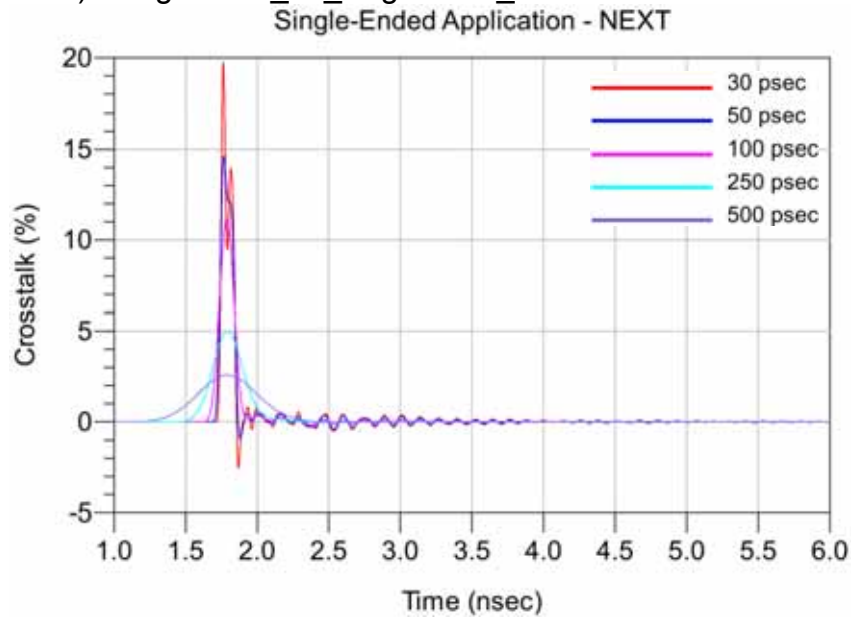

Case 2 (Long Row) - Edge-Card_22_Edge-Card_24

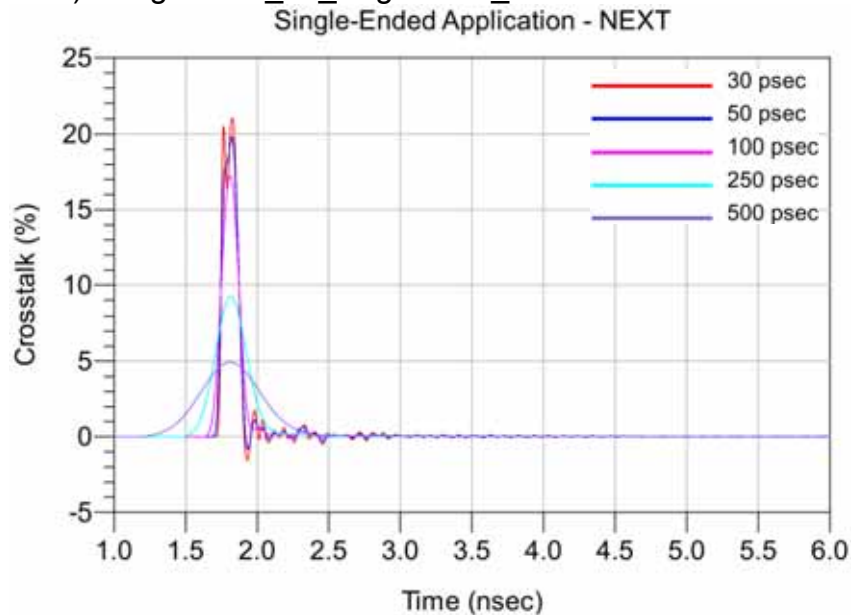

Series: MEC8-RA Series

Description: Mini Edge Card Right Angle, 0.8mm Pitch, mates to 1.6mm thick card

Single-Ended Application – FEXT, Worst Case Configuration

Case 1 (Short Row) - Edge-Card_21_MEC8-RA_23

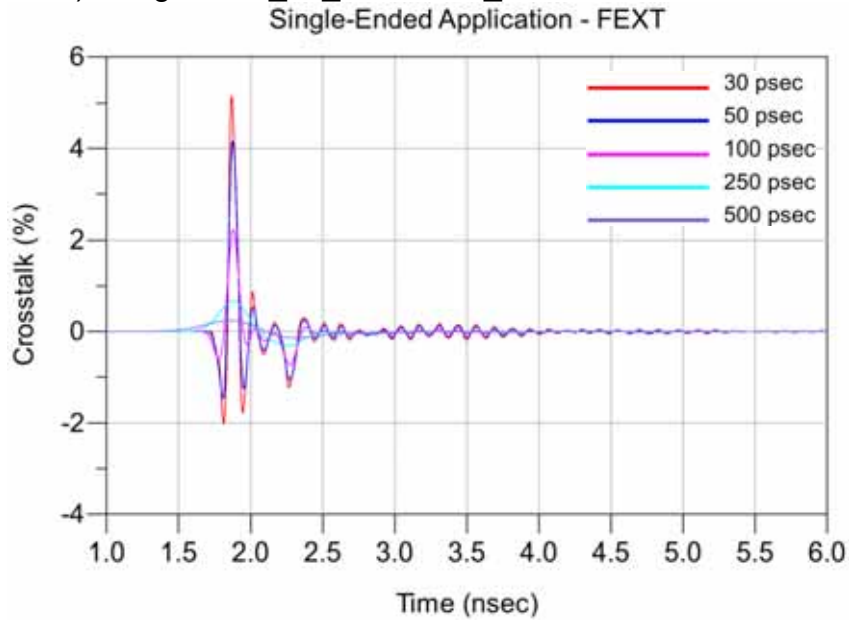

Case 2 (Long Row) - Edge-Card_22_MEC8-RA_24

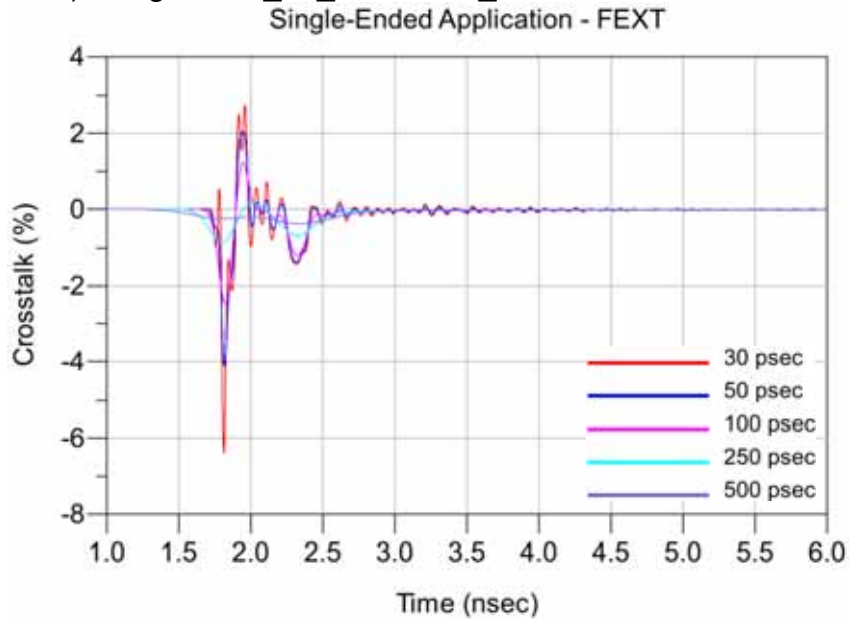

Series: MEC8-RA Series

Description: Mini Edge Card Right Angle, 0.8mm Pitch, mates to 1.6mm thick card

Single-Ended Application – NEXT, Best Case Configuration

Case 1 (Short Row) - Edge-Card_61_Edge-Card_65

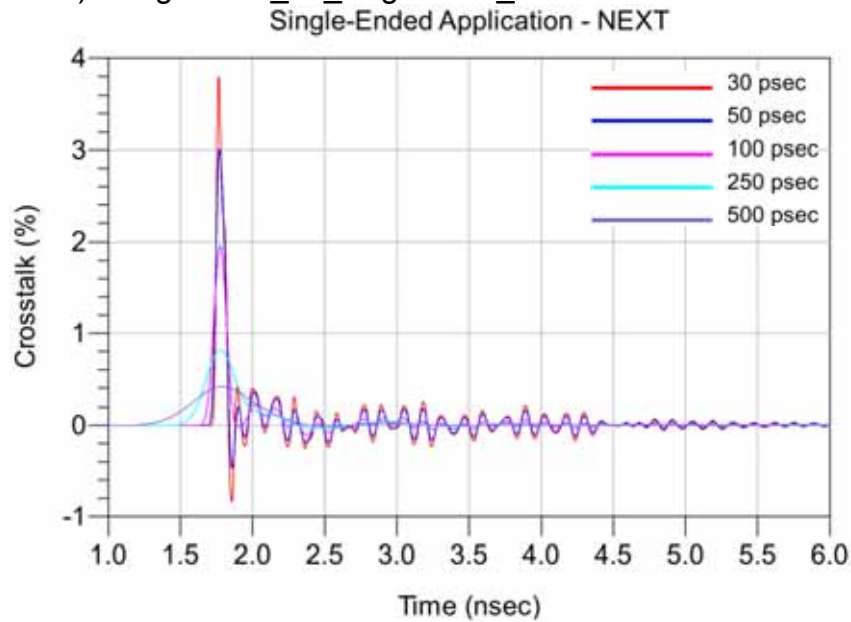

Case 2 (Long Row) - Edge-Card_62_Edge-Card_66

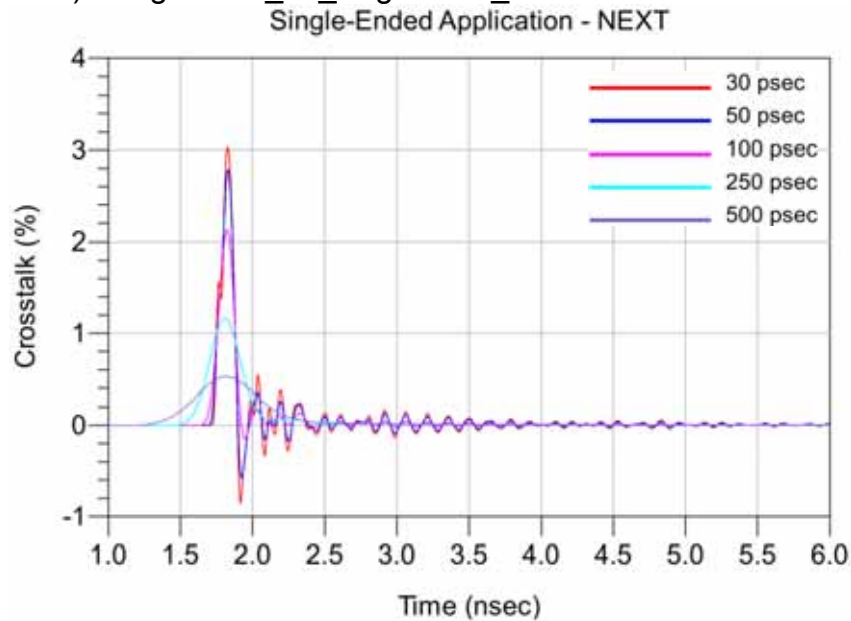

Series: MEC8-RA Series

Description: Mini Edge Card Right Angle, 0.8mm Pitch, mates to 1.6mm thick card

Single-Ended Application – FEXT, Best Case Configuration

Case 1 (Short Row) – Edge-Card_61_MEC8-RA_65

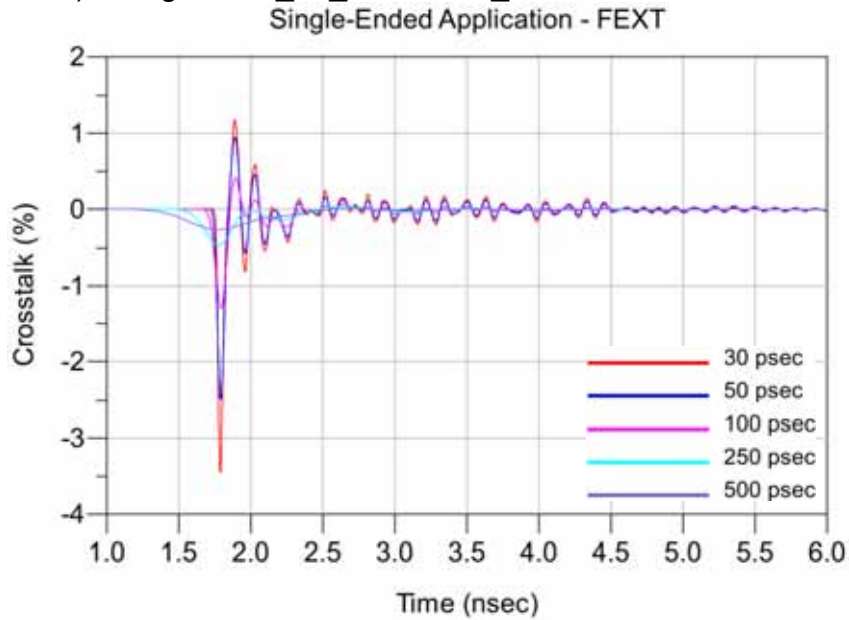

Case 2 (Long Row) – Edge-Card_62_MEC8-RA_66

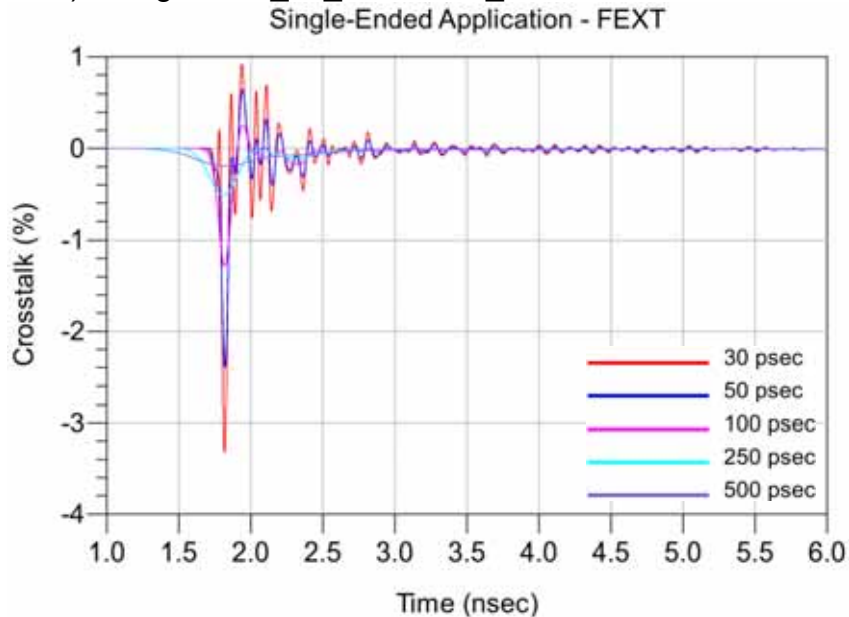

Series: MEC8-RA Series

Description: Mini Edge Card Right Angle, 0.8mm Pitch, mates to 1.6mm thick card

Single-Ended Application – NEXT, Across Row Configuration

Edge-Card_61_Edge-Card_62

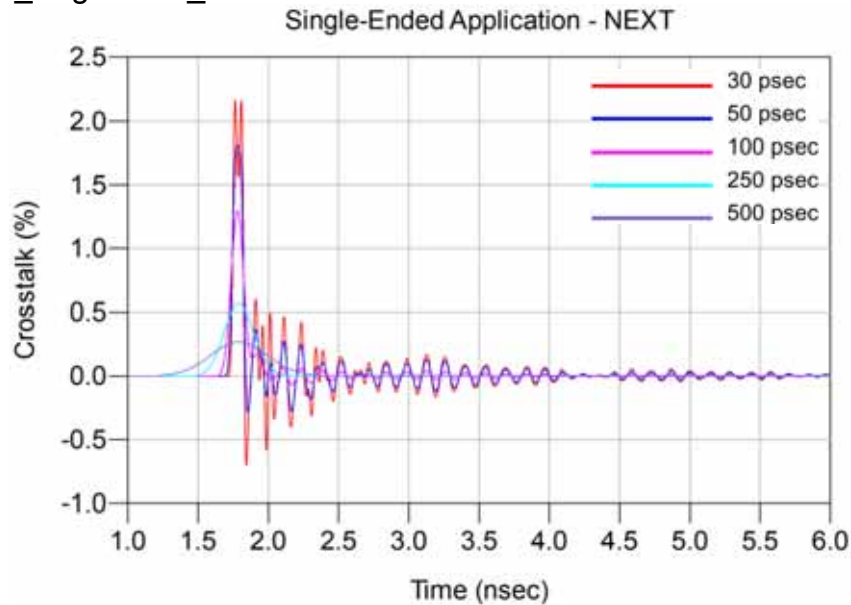

Single-Ended Application – FEXT, Across Row Configuration

Edge-Card_62_MEC8-RA_61

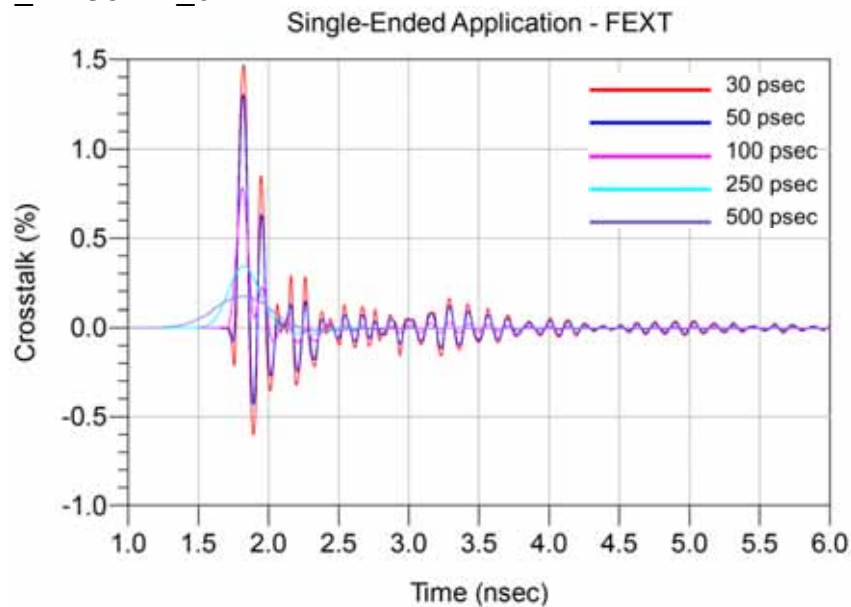

Series: MEC8-RA Series

Description: Mini Edge Card Right Angle, 0.8mm Pitch, mates to 1.6mm thick card

Differential Application – Input Pulse

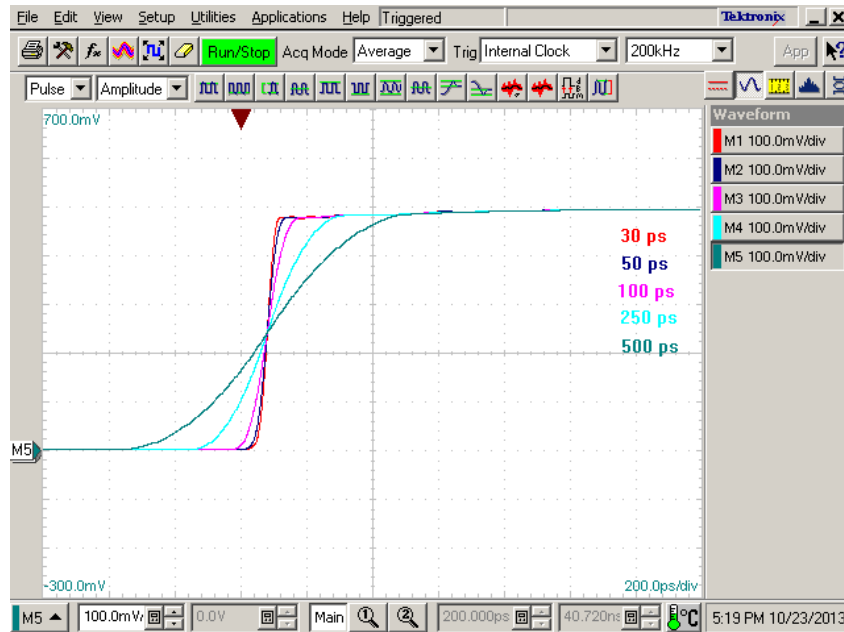

Series: MEC8-RA Series

Description: Mini Edge Card Right Angle, 0.8mm Pitch, mates to 1.6mm thick card

Differential Application – Impedance

Case 1 (Short Row)

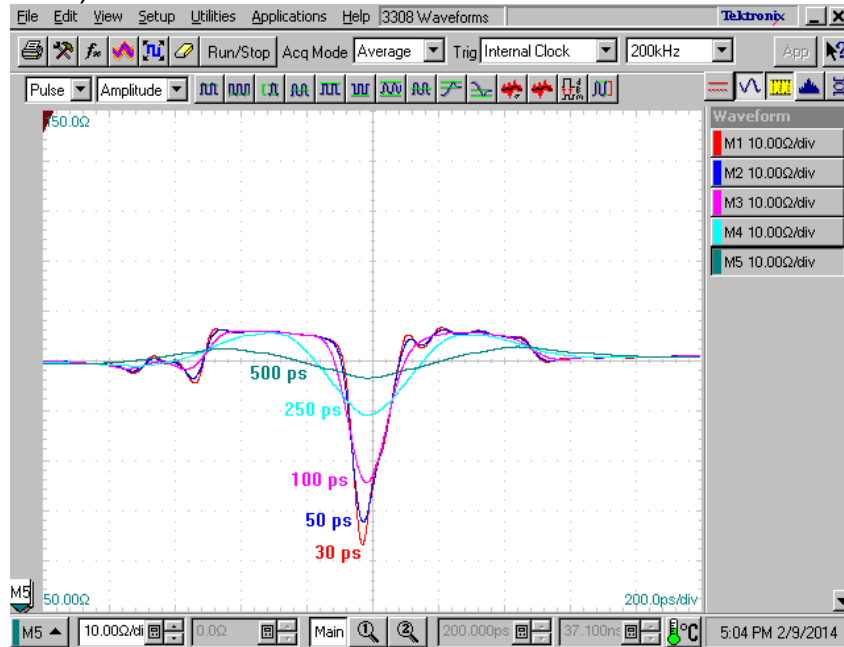

Case 2 (Long Row)

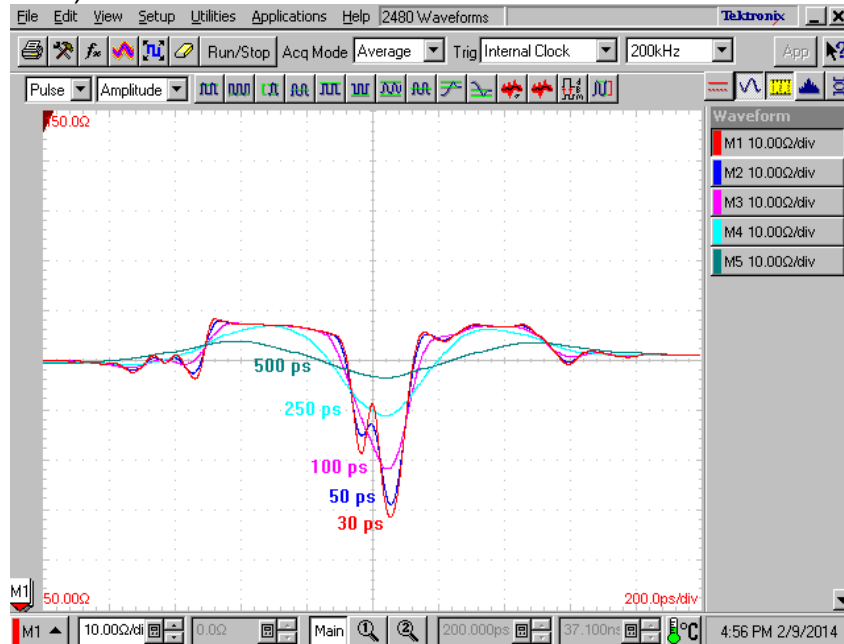

Series: MEC8-RA Series

Description: Mini Edge Card Right Angle, 0.8mm Pitch, mates to 1.6mm thick card

Differential Application – Propagation Delay

Case 1 (Short Row)

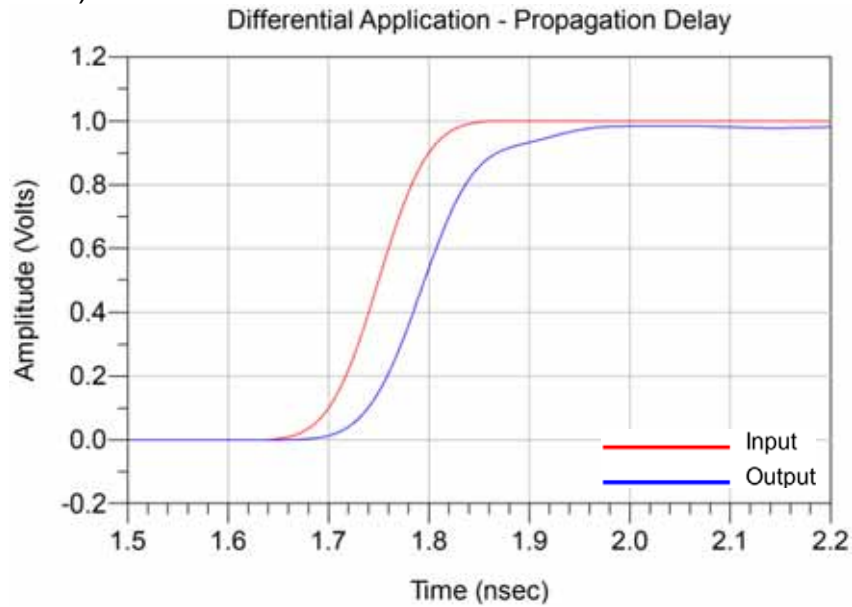

Case 2 (Long Row)

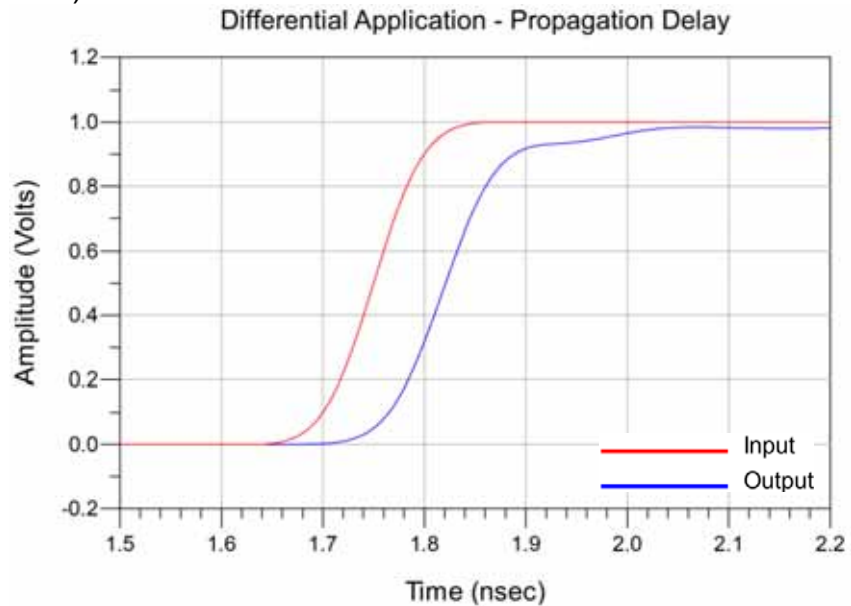

Series: MEC8-RA Series

Description: Mini Edge Card Right Angle, 0.8mm Pitch, mates to 1.6mm thick card

Differential Application – NEXT, Worst Case Configuration

Case 1 (Short Row) – Edge-Card_27,29_Edge-Card_31,33

Differential Application - NEXT

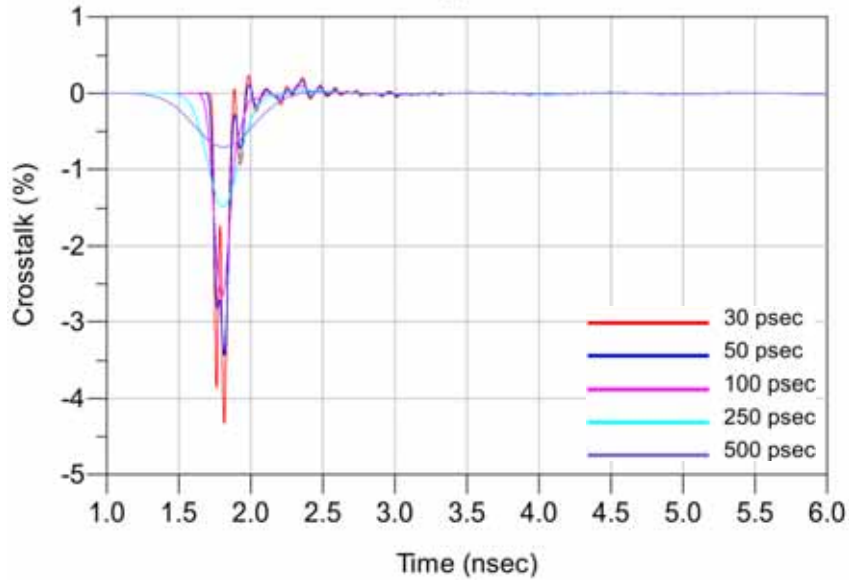

Case 2 (Long Row) – Edge-Card_28,30_Edge-Card_32,34

Differential Application - NEXT

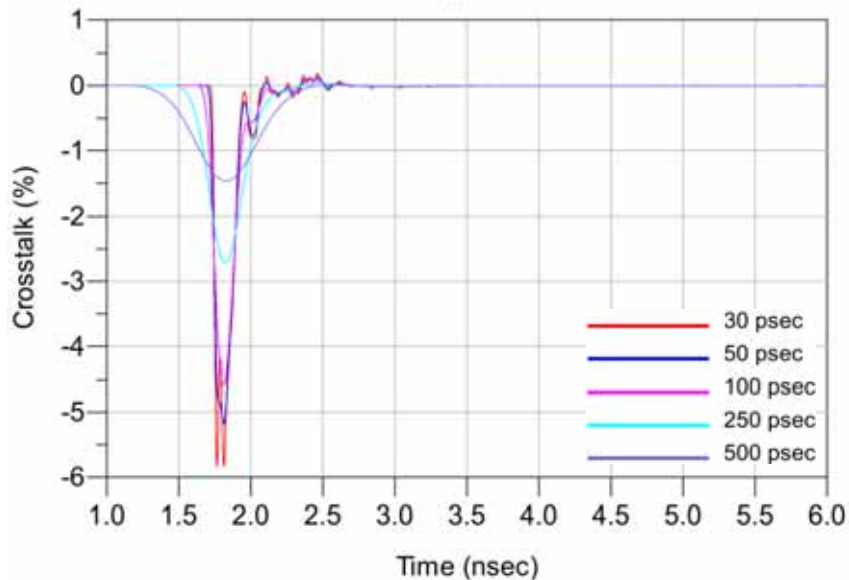

Series: MEC8-RA Series

Description: Mini Edge Card Right Angle, 0.8mm Pitch, mates to 1.6mm thick card

Differential Application – FEXT, Worst Case Configuration

Case 1 (Short Row) – Edge-Card_27,29_MEC8-RA_31,33

Differential Application - FEXT

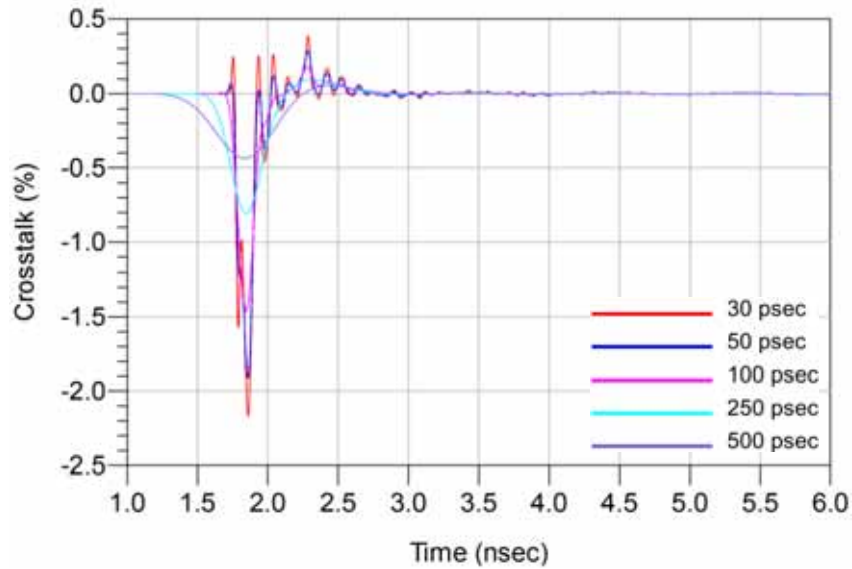

Case 2 (Long Row) – Edge-Card_28,30_MEC8-RA_32,34

Differential Application - FEXT

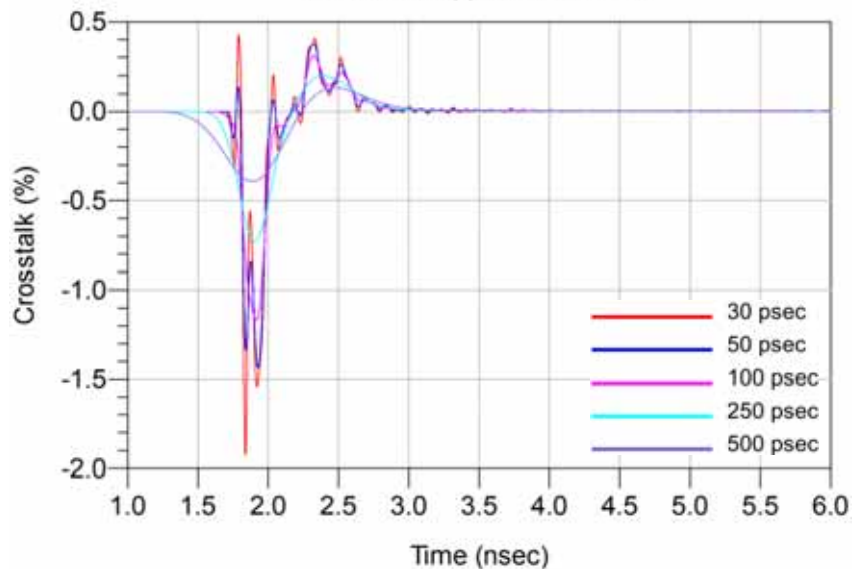

Series: MEC8-RA Series

Description: Mini Edge Card Right Angle, 0.8mm Pitch, mates to 1.6mm thick card

Differential Application – NEXT, Best Case Configuration

Case 1 (Short Row) – Edge-Card_27,29_Edge-Card_33,35

Differential Application - NEXT

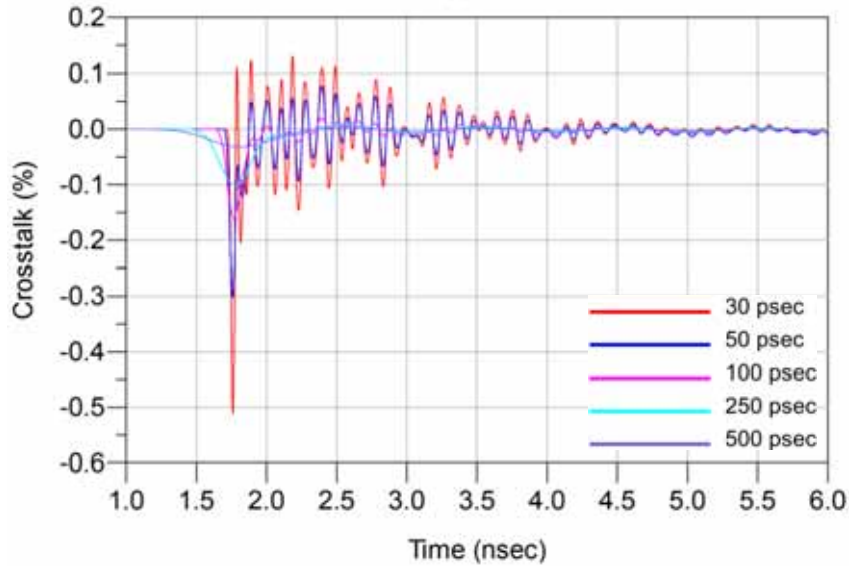

Case 2 (Long Row) – Edge-Card_28,30_Edge-Card_34,36

Differential Application - NEXT

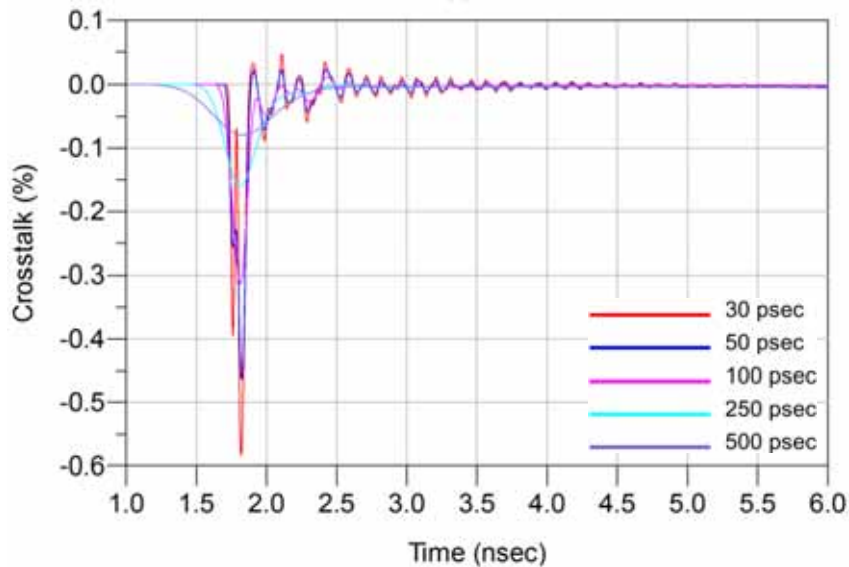

Series: MEC8-RA Series

Description: Mini Edge Card Right Angle, 0.8mm Pitch, mates to 1.6mm thick card

Differential Application – FEXT, Best Case Configuration

Case 1 (Short Row) – Edge-Card_27,29_MEC8-RA_33,35

Differential Application - FEXT

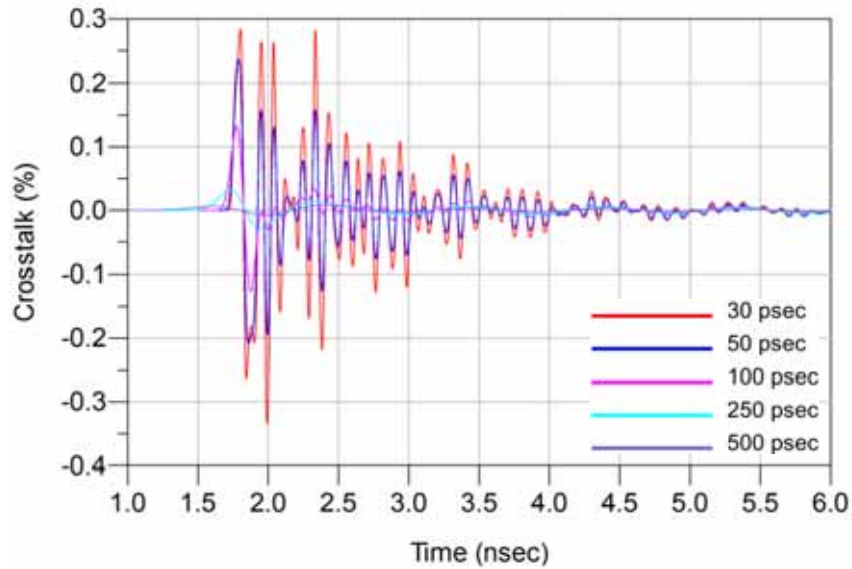

Case 2 (Long Row) – Edge-Card_28,30_MEC8-RA_34,36

Differential Application - FEXT

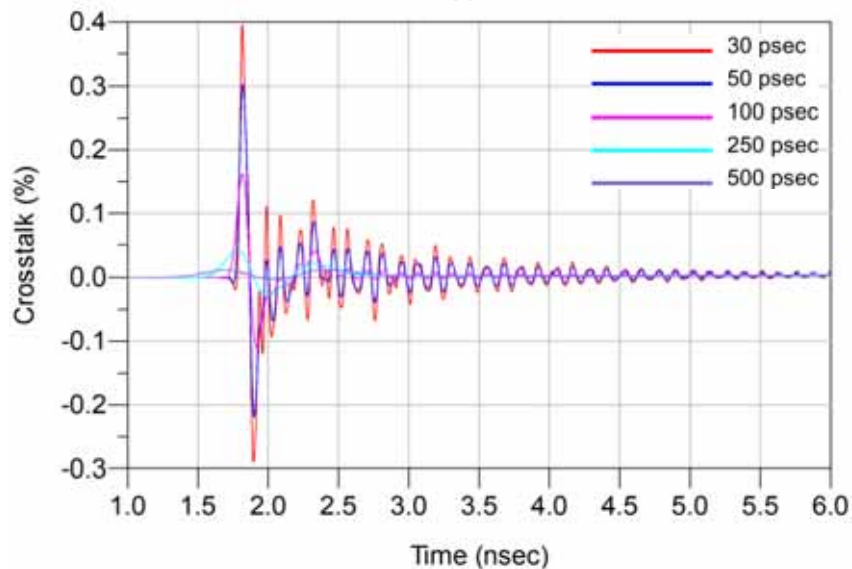

Series: MEC8-RA Series

Description: Mini Edge Card Right Angle, 0.8mm Pitch, mates to 1.6mm thick card

Differential Application – NEXT, Across Row Case Configuration

Edge-Card_21,23_Edge-Card_22,24

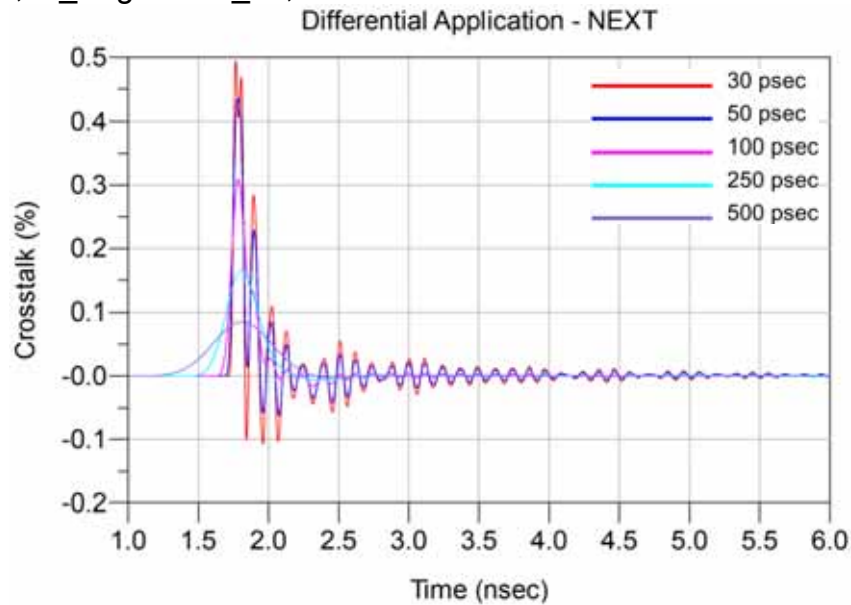

Differential Application – FEXT, Across Row Case Configuration

Edge-Card_22,24_MEC8-RA_21,23

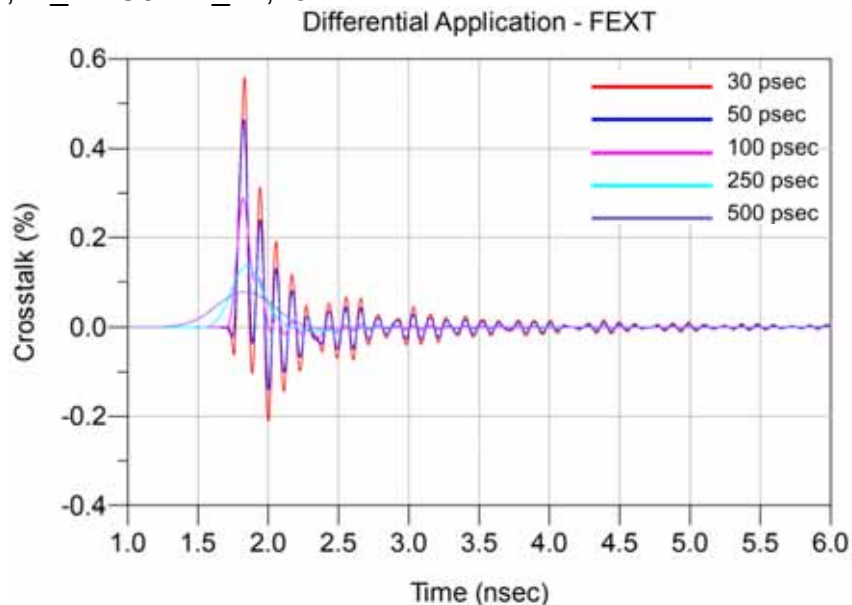

Series: MEC8-RA Series

Description: Mini Edge Card Right Angle, 0.8mm Pitch, mates to 1.6mm thick card

Appendix C – Product and Test System Descriptions

Product Description

Product test samples are MEC8-RA series connectors. The part number is MEC8-140-02-L-D-RA1. The MEC8-RA Series is a right angle and PCB surface mount product. Each connector has two rows of contacts evenly spaced on a 0.8mm (0.0315") pitch. The right angle design forces the top row terminals to have a longer electrical length than those of the bottom row; hence, the electrical characteristics between the short row and long row will differentiate. When mated the connector and the edge-card locate on a parallel. A photo of the test articles mounted to SI test boards is shown below.

Test System Description

The test fixtures are composed of four-layer FR-4 material with 50Ω signal trace and pad configurations designed for the electrical characterization of Samtec high speed connector products. A PCB mount SMA connector is used to interface the test cables to test fixtures. Optimization of the SMA launch was performed using full wave simulation tools to minimize reflections. Six test fixtures are specific to the MEC8-RA series connector set and identified by part numbers PCB-105901-SIG-05A and B through PCB-105901-SIG-07A and B. Calibration standards specific to the MEC8-RA series are located on the calibration boards PCB-105901-SIG-9. To keep trace lengths short, three different test board sets were required to access the necessary signal pins.

PCB-105901-SIG-XX Test Fixtures

Shown below is a photograph of the one of the three test board sets.

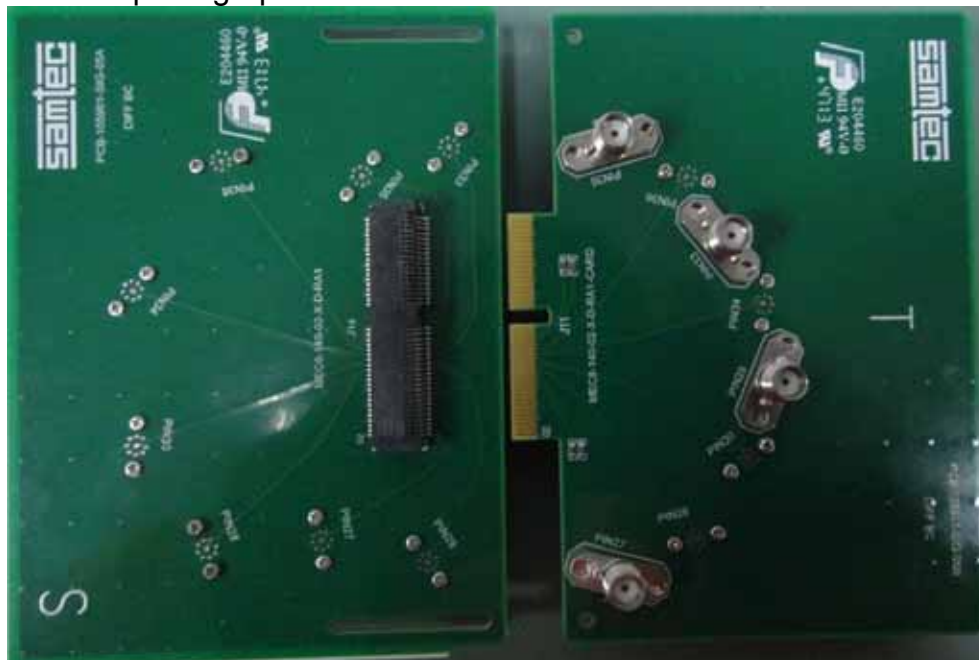

Series: MEC8-RA Series

Description: Mini Edge Card Right Angle, 0.8mm Pitch, mates to 1.6mm thick card

PCB-105901-SIG-XX PCB Layout Panel

Artwork of the PCB design is shown below.

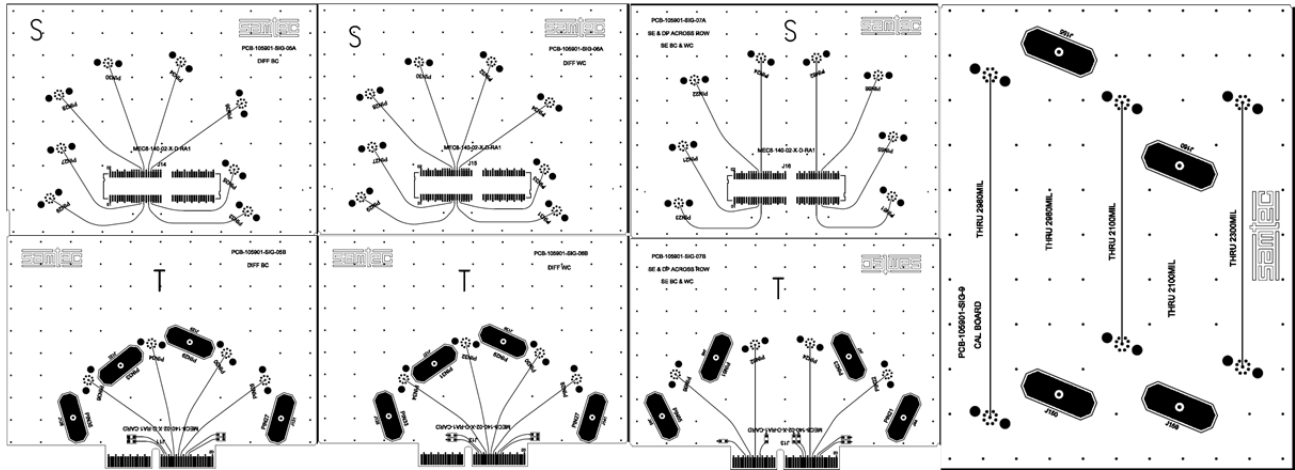

PCB Fixtures

The test fixtures used are as follows:

PCB-105901-SIG-05A – MEC8-RA Series Test Board for differential best-case for long pin and short pin

PCB-105901-SIG-05B – Edge-Card for differential best-case for long pin and short pin

PCB-105901-SIG-06A – MEC8-RA Series Test Board for differential worst-case for long pin and short pin

PCB-105901-SIG-06B – Edge-Card for differential worst-case for long pin and short pin

PCB-105901-SIG-07A – MEC8-RA Series Test Board for single-ended best-case and worst-case for long pin and short pin, single-ended and differential across-row

PCB-105901-SIG-07B – Edge-Card for single-ended best-case and worst-case for long pin and short pin, single-ended and differential across-row

Series: MEC8-RA Series

Description: Mini Edge Card Right Angle, 0.8mm Pitch, mates to 1.6mm thick card

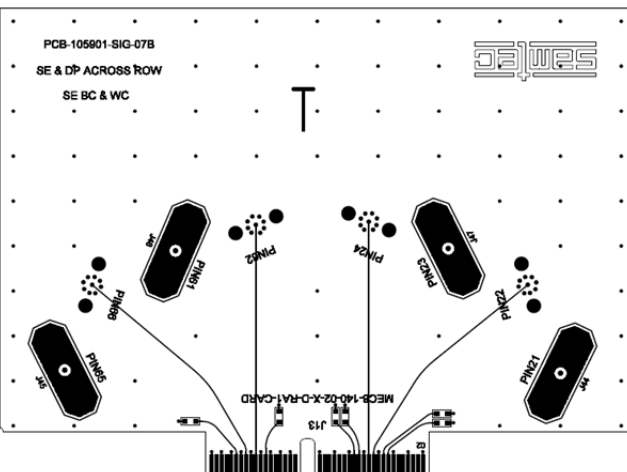
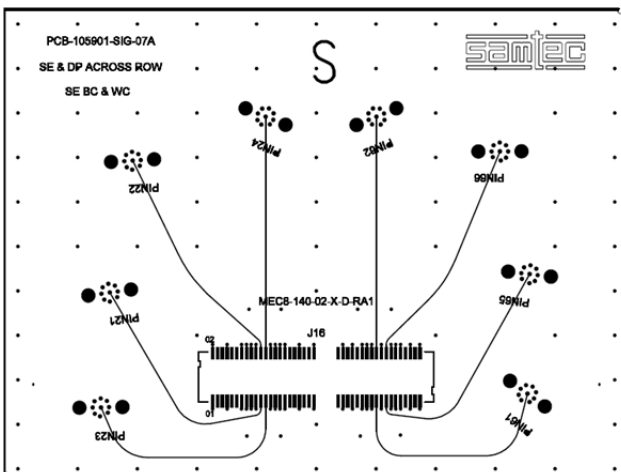
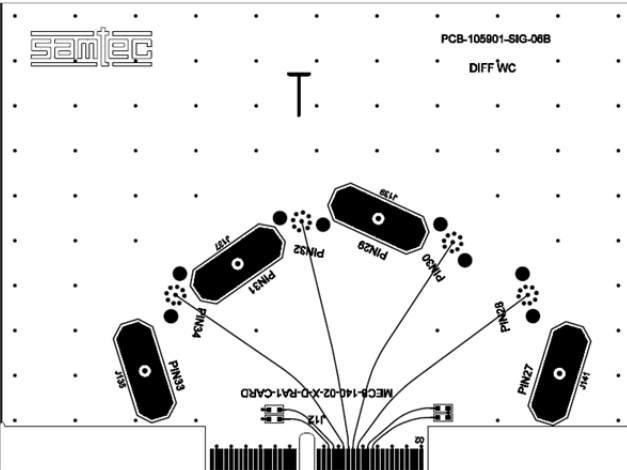
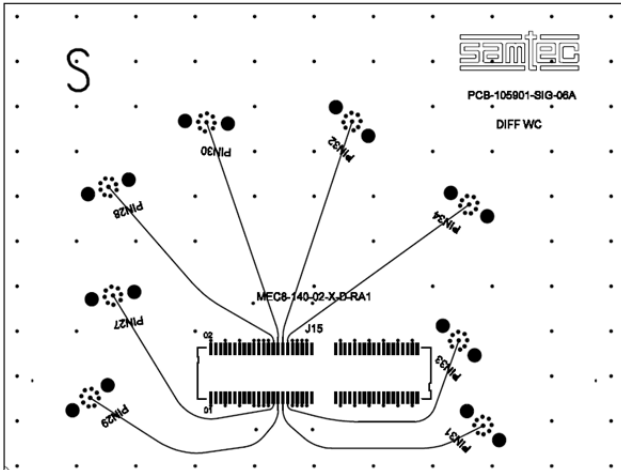
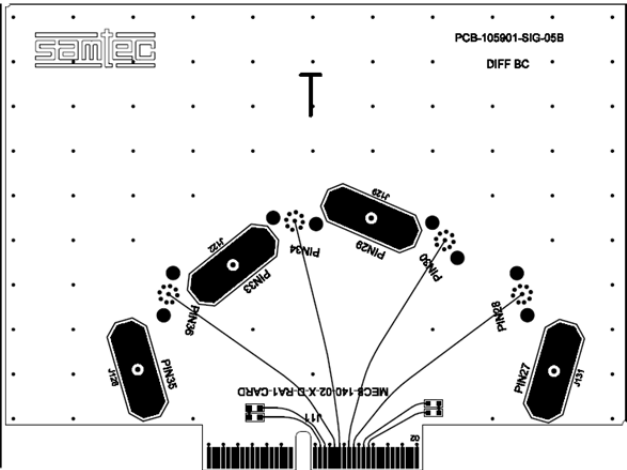
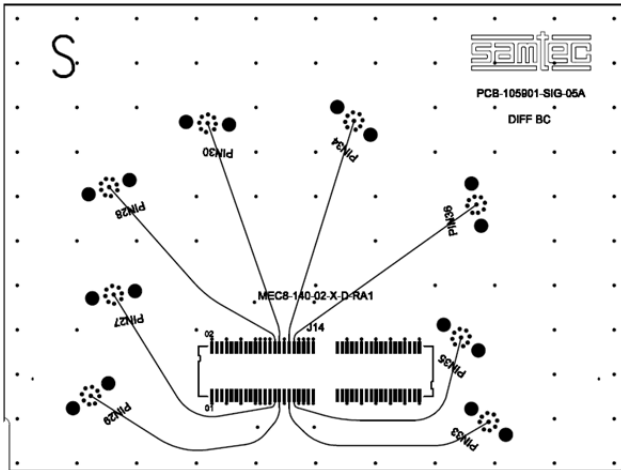

Series: MEC8-RA Series

Description: Mini Edge Card Right Angle, 0.8mm Pitch, mates to 1.6mm thick card

Calibration Board

Test fixture losses and test point reflections were removed from the data by use of Automatic Fixture Removal (AFR) application. The calibration board is shown below. The measurements were performed under SOLT calibration and the test board effects were included in the measurements. AFR application extracts fixture S-parameters from 2X THRU measurement and performs de-embedding on the DUT+Fixture measurement to characterize only the DUT.

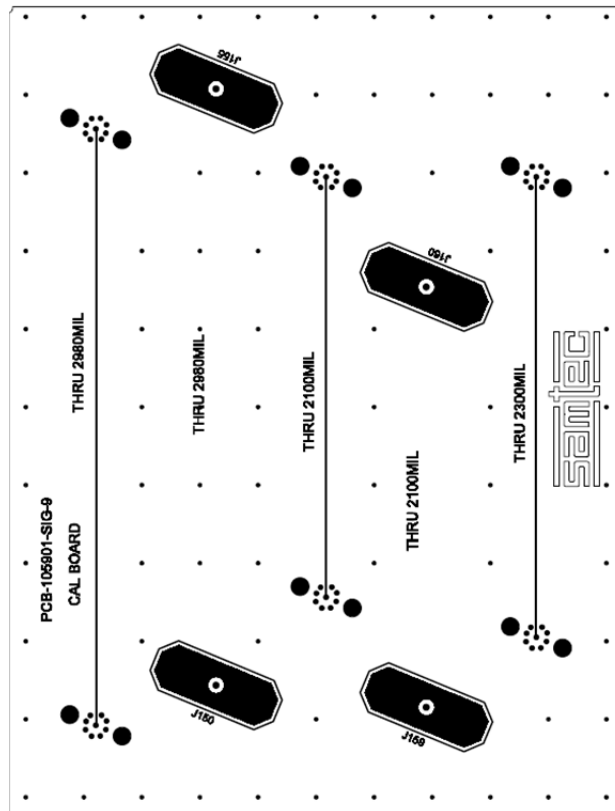

THRU line – 2980 mils

Series: MEC8-RA Series

Description: Mini Edge Card Right Angle, 0.8mm Pitch, mates to 1.6mm thick card

All traces on the test boards are length matched to 1.5" measured from the edge of the pad to the SMA. The AFR application effectively removes 1.49" of test board trace effects. This means that 10 mils of test board trace length effects are included in the both sides of test boards in the measurement. The S-Parameter measurement includes:

- A- The MEC8-RA Series connector set
- B- Test board vias, pads (footprint effects) for the MEC8-RA connector side.
- C- 10 mils of 9.5 mil wide microstrip trace.
- D- Test board vias, pads (footprint effects) for the Edge-Card side.
- E- 10 mils of 9.5 mil wide microstrip trace.

The figure below shows the location of the reference plane performing AFR application.

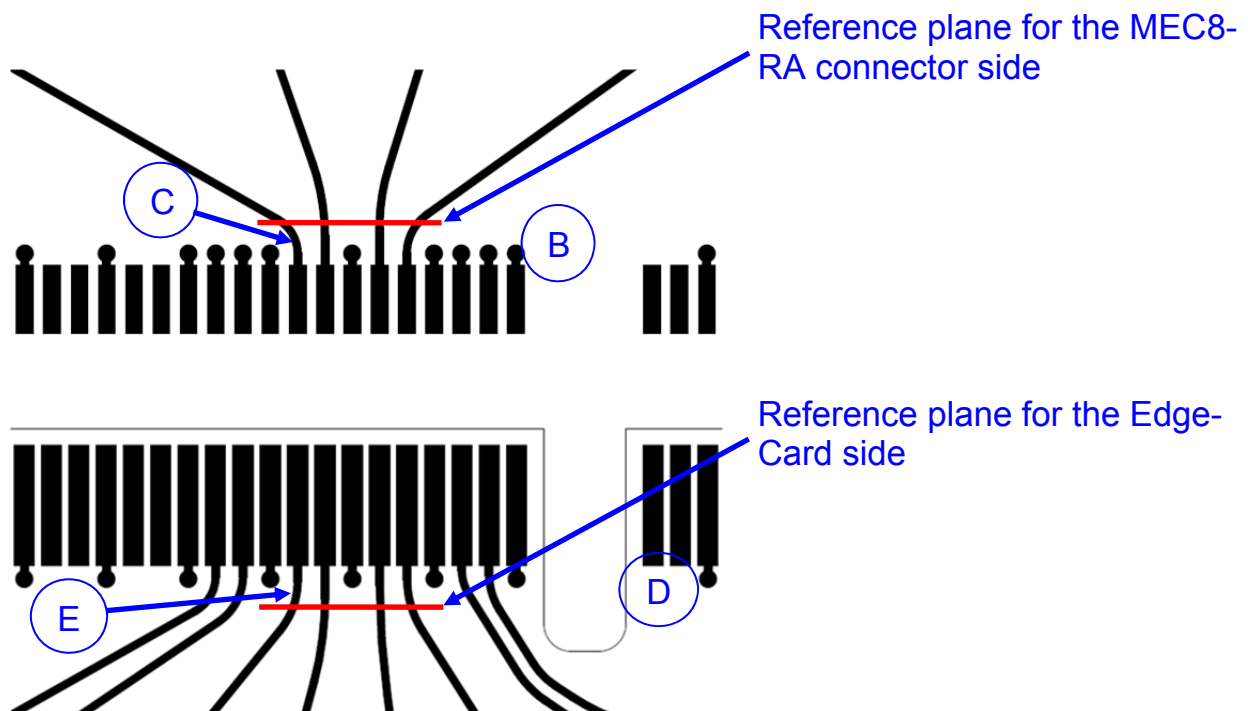

Series: MEC8-RA Series

Description: Mini Edge Card Right Angle, 0.8mm Pitch, mates to 1.6mm thick card

Appendix D – Test and Measurement Setup

For frequency domain measurements, the test instrument is the Agilent N5230C PNA-L network analyzer. Frequency domain data and graphs are extracted from the instrument by AFR application. Post-processed time domain data and graphs are generated using convolution algorithms within Agilent ADS. The network analyzer is configured as follows:

Start Frequency – 300 KHz

Stop Frequency – 20 GHz

Number of points -1601

IFBW – 1 KHz

With these settings, the measurement time is approximately 20 seconds.

N5230C Measurement Setup



Test Instruments

<u>QTY</u>	<u>Description</u>
1	Agilent N5230C PNA-L Network Analyzer (300 KHz to 20 GHz)
1	Agilent N4433A ecal module (300 KHz to 20 GHz)

Test Cables & Adapters

<u>QTY</u>	<u>Description</u>
4	Gore OWD01D02039-4 (DC-50 GHz)

Series: MEC8-RA Series

Description: Mini Edge Card Right Angle, 0.8mm Pitch, mates to 1.6mm thick card

For impedance measurements, the test instrument is the Tektronix DSA8200 Digital Serial Analyzer mainframe and 80E04 sampling module. The impedance data and profiles are obtained directly from the instrument. The Digital Analyzer is configured as follows:

	Single-Ended Signal	Differential Signal
Vertical Scale:	5 ohm / Div:	10 ohm/ Div:
Offset:	Default / Scroll	Default / Scroll
Horizontal Scale:	200ps/ Div	200ps/ Div
Record Length:	4000	4000
Averages:	≥ 16	≥ 16

DSA8200 Measurement Setup



Test Instruments

<u>QTY</u>	<u>Description</u>
1	Tektronix DSA8200 Digital Serial Analyzer
2	Tektronix 80E04 Dual Channel 20 GHz TDR Sampling Module

Test Cables & Adapters

<u>QTY</u>	<u>Description</u>
2	Samtec RF405-01SP1-01SP1-0305 (DC-20 GHz)

Series: MEC8-RA Series

Description: Mini Edge Card Right Angle, 0.8mm Pitch, mates to 1.6mm thick card

Appendix E - Frequency and Time Domain Measurements

Frequency (S-Parameter) Domain Procedures

The quality of any data taken with a network analyzer is directly related to the quality of the calibration standards and the use of proper test procedures. For this reason, extreme care is taken in the design of the through calibration standards, the SI test boards, and the selection of the PCB vendor.

A coaxial SOLT calibration is performed using an N4433A ecal module. Then DUT measurements are performed under SOLT calibration. The measurements include the effect of test fixture. The measurements of the 2X THRU line standards are required in order to remove the test fixture effect.

Time Domain Procedures

Mathematically, Frequency Domain data can be transformed to obtain a Time Domain response. Perfect transformation requires Frequency Domain data from DC to infinity Hz. Fortunately, a very accurate Time Domain response can be obtained with bandwidth-limited data, such as measured with modern network analyzer.

The Time Domain responses were generated using Agilent ADS 2009 update 1. This tool has a transient convolution simulator, which can generate a Time Domain response directly from measured S-Parameters. An example of a similar methodology is provided in the Samtec Technical Note on domain transformation.

[http://www.samtec.com/Technical_Library/reference/articles/pdfs/tech-note_using-PLTS-for-time-domain-data_web.pdf](http://www.samtec.com/Technical_Library/reference/articles/pdfs/tech-note_using_PLTS-for-time-domain-data_web.pdf)

Propagation Delay (TDT)

The Propagation Delay is a measure of the Time Domain delay through the connector and footprint. A step pulse is applied to the touchstone model of the connector and the transmitted voltage is monitored. The same pulse is also applied to a reference channel with zero loss, and the Time Domain pulses are plotted on the same graph. The difference in time, measured at the 50% point of the step voltage is the propagation delay.

Near-End Crosstalk (TDT) & Far End Crosstalk (TDT)

A step pulse is applied to the touchstone model of the connector and the coupled voltage is monitored. The amplitude of the peak-coupled voltage is recorded and reported as a percentage of the input pulse.

Series: MEC8-RA Series

Description: Mini Edge Card Right Angle, 0.8mm Pitch, mates to 1.6mm thick card

Impedance (TDR)

Measurements involving digital pulses are performed using either Time Domain Reflectometer (TDR) or Time Domain Transmission (TDT) methods. The TDR method is used for the impedance measurements in this report.

The signal line(s) of the SUT's is energized with a TDR pulse and the far-end of the energized signal line is terminated in the test systems characteristic impedance (e.g.; 50 Ω or 100 Ω terminations). By terminating the adjacent signal lines in the test systems characteristic impedance, the effects on the resultant impedance shape of the waveform is limited. The "best case" signal mapping was tested and is presented in this report.

Series: MEC8-RA Series

Description: Mini Edge Card Right Angle, 0.8mm Pitch, mates to 1.6mm thick card

Appendix F – Glossary of Terms

ADS – Advanced Design Systems

AFR – Automatic Fixture Removal

BC – Best Case crosstalk configuration

DUT – Device under test, term used for TDA IConnect & Propagation Delay waveforms

FD – Frequency domain

FEXT – Far-End Crosstalk

GSG – Ground–Signal–Ground; geometric configuration

GSSG - Ground–Signal–Signal–Ground; geometric configuration

HDV – High Density Vertical

NEXT – Near-End Crosstalk

OV – Optimal Vertical

OH – Optimal Horizontal

PCB – Printed Circuit Board

PPO – Pin Population Option

SE – Single-Ended

SI – Signal Integrity

SUT – System Under Test

S – Static (independent of PCB ground)

SOLT – acronym used to define Short, Open, Load & Thru Calibration Standards

TD – Time Domain

TDA – Time Domain Analysis

TDR – Time Domain Reflectometry

TDT – Time Domain Transmission

WC – Worst Case crosstalk configuration

Z – Impedance (expressed in ohms)