

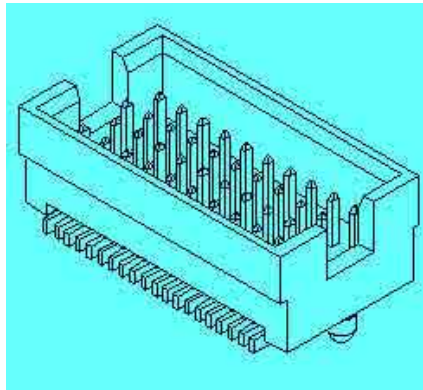

## High Speed Characterization Report

**TOLC-110-02-S-Q-L-C**



**Mated With**

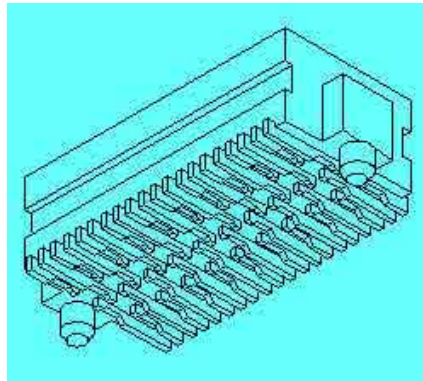

**SOLC-110-02-S-Q-L-C**

### **Description:**

**Quad Row, Surface Mount, Board-to-Board Connector Series,  
1.27mm Pitch, 6.35mm (0.250") Stack Height**

**Series:** TOLC/SOLC, 1.27mm (0.050”) Contact Pitch, 0.64mm (0.025”) Footprint Pitch  
**Description:**, Board-to-Board, Surface Mount, 6.35mm (0.250”) Stack Height

## Table of Contents

Connector Overview .....	1
Connector System Speed Rating .....	1
Frequency Domain Data Summary .....	2
Table 1 - Single-Ended Connector System Performance .....	2
Table 2 - Differential Connector System Performance .....	3
Bandwidth Chart - Single-Ended & Differential Insertion Loss .....	4
Time Domain Data Summary .....	5
Table 3 - Single-Ended Impedance ( $\Omega$ ) .....	5
Table 4 - Differential Impedance ( $\Omega$ ) .....	5
Table 5 - Single-Ended Crosstalk (%) .....	6
Table 6 - Differential Crosstalk (%) .....	7
Table 7 - Propagation Delay (Mated Connector) .....	8
Characterization Details .....	9
Differential and Single-Ended Data .....	9
Connector Signal to Ground Ratio .....	9
Frequency Domain Data .....	12
Time Domain Data .....	12
Appendix A – Frequency Domain Response Graphs .....	14
Single-Ended Application – Insertion Loss .....	14
Single-Ended Application – Return Loss .....	14
Single-Ended Application – NEXT .....	15
Single-Ended Application – FEXT .....	15
Differential Application – Insertion Loss .....	16
Differential Application – Return Loss .....	16
Differential Application – NEXT .....	17
Differential Application – FEXT .....	17
Appendix B – Time Domain Response Graphs .....	18
Single-Ended Application – Input Pulse .....	18
Single-Ended Application – Impedance .....	19
Single-Ended Application – Propagation Delay .....	19
Single-Ended Application – NEXT .....	20
Single-Ended Application – FEXT .....	20
Single-Ended Application – NEXT .....	21
Single-Ended Application – FEXT .....	21
Single-Ended Application – NEXT .....	22
Single-Ended Application – FEXT .....	22
Single-Ended Application – NEXT .....	23
Single-Ended Application – FEXT .....	23
Differential Application – Input Pulse .....	24

**Series:** TOLC/SOLC, 1.27mm (0.050”) Contact Pitch, 0.64mm (0.025”) Footprint Pitch  
**Description:**, Board-to-Board, Surface Mount, 6.35mm (0.250”) Stack Height

Differential Application – Impedance .....	25
Differential Application – Propagation Delay.....	25
Differential Application – NEXT .....	26
Differential Application – FEXT .....	26
Differential Application – NEXT .....	27
Differential Application – FEXT .....	27
Differential Application – NEXT .....	28
Differential Application – FEXT .....	28
Differential Application – NEXT .....	29
Differential Application – FEXT .....	29
Differential Application – NEXT .....	30
Differential Application – FEXT .....	30
Appendix C – Product and Test System Descriptions .....	31
Product Description .....	31
Test System Description.....	31
Signal Launch and Monitoring Map.....	32
SOLC, J1 / TOLC, J2 Connector/Footprint Pinout Map.....	33
SOLC, J8 / TOLC, J3 Connector/Footprint Pinout Map.....	33
SOLC, J15 / TOLC, J4 Connector/Footprint Pinout Map.....	33
SOLC, J22 / TOLC, J5 Connector/Footprint Pinout Map.....	33
Appendix D – Test and Measurement Setup.....	33
Test Instruments & Accessories .....	33
Test Setup Configurations .....	33
Appendix E - Frequency and Time Domain Measurements .....	33
Frequency (S-Parameter) Domain Procedures .....	33
CSA8000 Setup .....	33
Insertion Loss.....	33
Return Loss.....	33
Near-End Crosstalk (NEXT).....	33
Far-End Crosstalk (FEXT).....	33
Time Domain Procedures .....	33
Impedance .....	33
Propagation Delay.....	33
Crosstalk .....	33
Appendix F – Glossary of Terms.....	33

**Series:** TOLC/SOLC, 1.27mm (0.050") Contact Pitch, 0.64mm (0.025") Footprint Pitch  
**Description:**, Board-to-Board, Surface Mount, 6.35mm (0.250") Stack Height

### Connector Overview

SOLC/TOLC Series interfaces are available as a 1.27mm (.050") square pitch quad row connector system. The staggered row system results in a surface mount 0.635mm (.025") terminal pitch. The quad series is available with up to 50 contacts per row and has standard board-to-board spacings of 6.35mm (0.250) and 12mm (0.472). The data in this report is applicable only to the 6.35mm (0.250) board-to-board stack height version.

### Connector System Speed Rating

SOLC/TOLC Series, Quad Row, 1.27mm (.050") pitch, 6.35mm (0.250") Stack Height

<u>Signaling</u>	<u>Speed Rating</u>
Single-Ended:	<b>7 GHz / 14 Gbps</b>
Differential:	<b>6.5 GHz / 13 Gbps</b>

The Speed Rating is based on the -3 dB insertion loss point of the connector system. The -3 dB point can be used to estimate usable system bandwidth in a typical, two-level signaling environment.

To calculate the Speed Rating, the measured -3 dB point is rounded up to the nearest half-GHz level. The up-rounding corrects for a portion of the test board's trace loss, since trace losses are included in the loss data in this report. The resulting loss value is then doubled to determine the approximate maximum data rate in Gigabits per second (Gbps).

For example, a connector with a -3 dB point of 7.8 GHz would have a Speed Rating of 8 GHz/ 16 Gbps. A connector with a -3 dB point of 7.2 GHz would have a Speed Rating of 7.5 GHz/ 15 Gbps.

**Series:** TOLC/SOLC, 1.27mm (0.050") Contact Pitch, 0.64mm (0.025") Footprint Pitch  
**Description:**, Board-to-Board, Surface Mount, 6.35mm (0.250") Stack Height

## Frequency Domain Data Summary

Table 1 - Single-Ended Connector System Performance			
Test Parameter	Source	Victim	
Insertion Loss	port1=J6; port2=J35		<b>-3dB @ 6.72 GHz</b>
Return Loss	port1=J6; port2=J35		≤ -5 dB to 6.72GHz
Near-End Crosstalk	J6 (SE1)	J9 (SE1)	≤ -10dB to 6.72GHz
	J9 (SE1)	J11 (SE1)	≤ -10dB to 6.72 GHz
	J16 (SE2)	J17 (SE2)	≤ -12dB to 6.72 GHz
Far-End Crosstalk	J6 (SE1)	J7 (SE1)	≤ -18dB to 6.72 GHz
	J6 (SE1)	J37 (SE1)	≤ -10dB to 6.72 GHz
	J9 (SE1)	J39 (SE1)	≤ -10dB to 6.72 GHz
	J16 (SE2)	J44 (SE2)	≤ -18dB to 6.72 GHz
	J6 (SE1)	J36 (SE1)	≤ -15dB to 6.72 GHz

Pin Map (reference Appendix C for full description of test boards)

SE1:

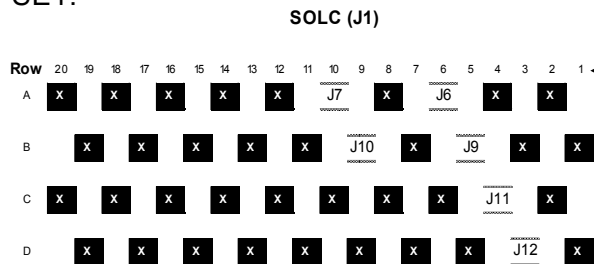

SE2:

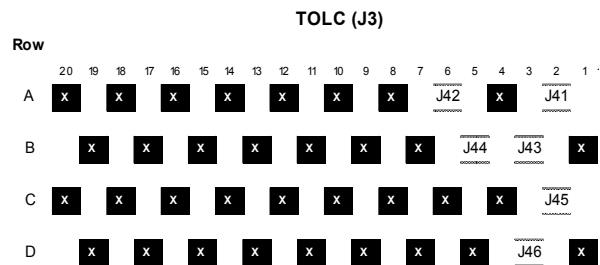
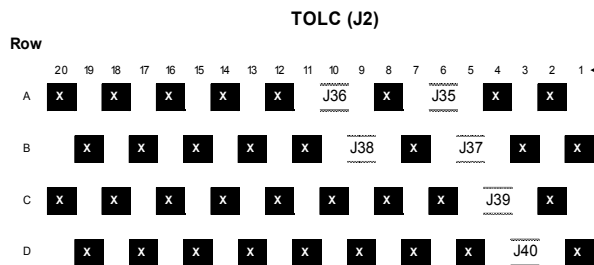
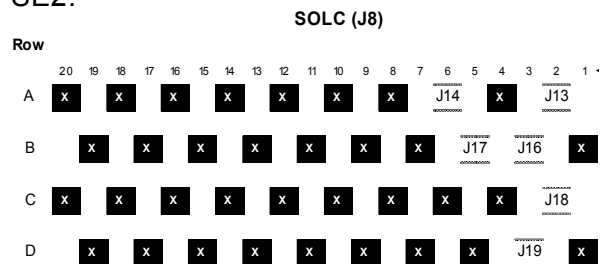

**Series:** TOLC/SOLC, 1.27mm (0.050") Contact Pitch, 0.64mm (0.025") Footprint Pitch  
**Description:**, Board-to-Board, Surface Mount, 6.35mm (0.250") Stack Height

Test Parameter	Source	Victim	
<b>Insertion Loss</b>	Port1= J21-J24		<b>-3dB @ 6.32 GHz</b>
	Port 2 = J48-J50		
<b>Return Loss</b>	Port1= J21-J24		≤ -5dB to 6.32 GHz
	Port 2 = J48-J50		
<b>Near-End Crosstalk</b>	J34-J28 (DP2)	J33-J27 (DP2)	≤ -18dB to 6.32 GHz
	J21-J24 (DP1)	J25-J26 (DP1)	≤ -35dB to 6.32 GHz
	J14-J17 (SE2)	J13-J16 (SE2)	≤ -38dB to 6.32 GHz
	J34-J28 (DP2)	J30-J32 (DP2)	≤ -38dB to 6.32 GHz
	J21-J24 (DP1)	J20-J23 (DP1)	≤ -38dB to 6.32 GHz
<b>Far-End Crosstalk</b>	J34-J28 (DP2)	J53-J55 (DP2)	≤ -22dB to 6.32 GHz
	J21-J24 (DP1)	J51-J52 (DP1)	≤ -32dB to 6.32 GHz
	J14-J17 (SE2)	J41-J43 (SE2)	≤ -40dB to 6.32 GHz
	J34-J28 (DP2)	J58-J60 (DP2)	≤ -38dB to 6.32 GHz
	J21-J24 (DP1)	J47-J49 (DP1)	≤ -38dB to 6.32 GHz

Pin Map (reference Appendix C for full description of test boards)

DP1:

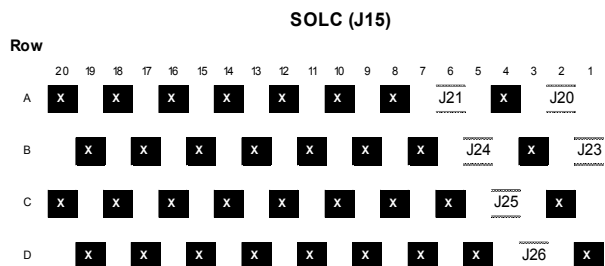

DP2:

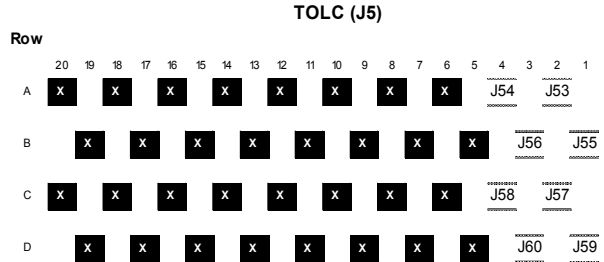
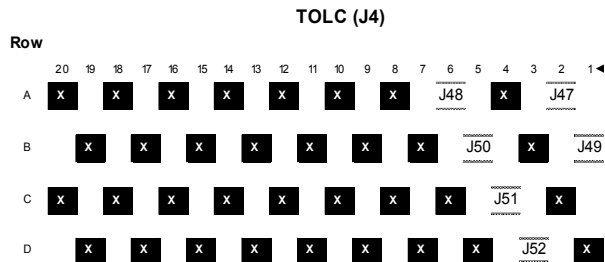
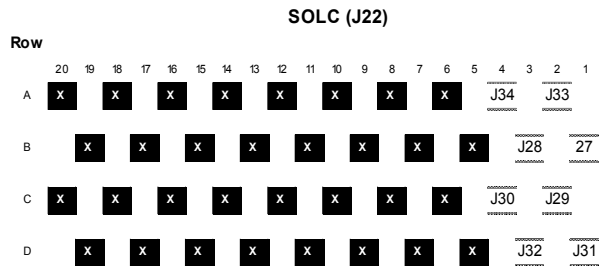

**Series:** TOLC/SOLC, 1.27mm (0.050") Contact Pitch, 0.64mm (0.025") Footprint Pitch  
**Description:**, Board-to-Board, Surface Mount, 6.35mm (0.250") Stack Height

## Bandwidth Chart - Single-Ended & Differential Insertion Loss

**PCB/Connector Test System**  
**Single Ended & Differential Signal Response**  
**SOLC/TOLC Quad Row Series**

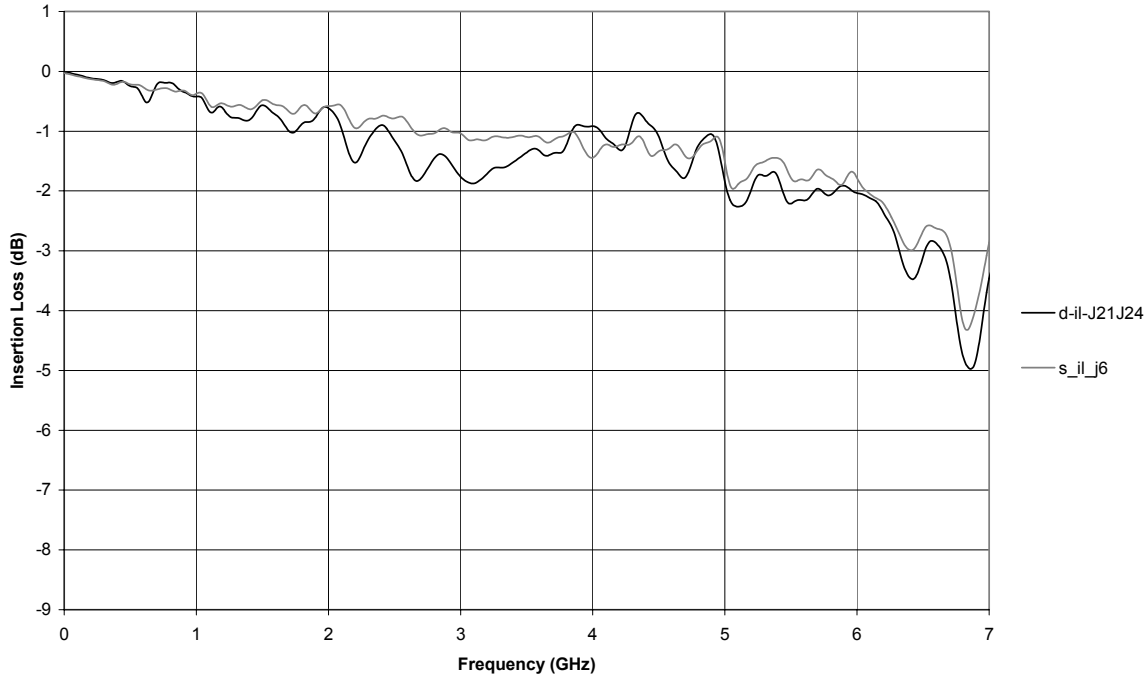

**Series:** TOLC/SOLC, 1.27mm (0.050") Contact Pitch, 0.64mm (0.025") Footprint Pitch  
**Description:**, Board-to-Board, Surface Mount, 6.35mm (0.250") Stack Height

## Time Domain Data Summary

Table 3 - Single-Ended Impedance ( $\Omega$ )							
Signal Risetime	30 $\pm$ 5ps	50 ps	100 ps	250 ps	500 ps	750 ps	1 ns
Maximum Impedance	61.7	54.4	53.4	51.7	50.8	50.4	50.1
Minimum Impedance	35.2	39.3	43.0	45.3	47.4	48.4	48.8

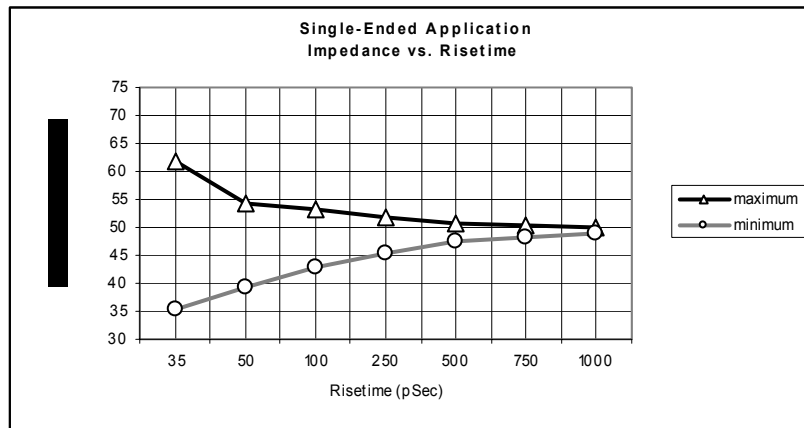
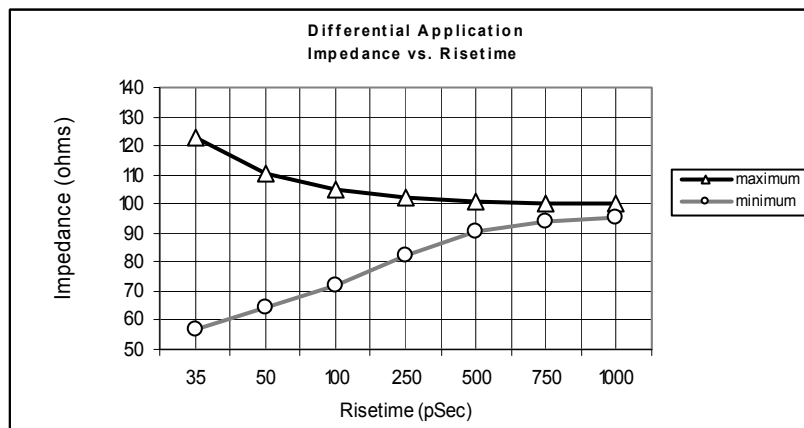

Table 4 - Differential Impedance ( $\Omega$ )							
Signal Risetime	30 $\pm$ 5ps	50 ps	100 ps	250 ps	500 ps	750 ps	1 ns
Maximum Impedance	123.0	110.2	105.0	102.1	100.8	100.2	100.1
Minimum Impedance	56.8	64.6	71.7	82.6	90.7	93.9	95.4



**Series:** TOLC/SOLC, 1.27mm (0.050") Contact Pitch, 0.64mm (0.025") Footprint Pitch  
**Description:**, Board-to-Board, Surface Mount, 6.35mm (0.250") Stack Height

Table 5 - Single-Ended Crosstalk (%)									
Input (t <sub>r</sub> )	Source	Victim	30±5ps	50 ps	100 ps	250 ps	500 ps	750 ps	1 ns
NEXT	J6 (SE1)	J9	10.6	8.3	4.9	2.8	2.8	2.0	1.5
	J9 (SE1)	J11	7.9	6.5	4.8	2.3	1.3	< 1.0%	< 1.0%
	J16 (SE2)	J17	7.5	5.9	4.6	2.6	1.5	1.0	< 1.0%
	J6 (SE1)	J7	2.2	1.7	1.2	< 1.0%	< 1.0%	< 1.0%	< 1.0%
FEXT	J6 (SE1)	J37	4.2	1.3	< 1.0%	< 1.0%	< 1.0%	< 1.0%	< 1.0%
	J9 (SE1)	J39	2.4	1.4	< 1.0%	< 1.0%	< 1.0%	< 1.0%	< 1.0%
	J16 (SE2)	J44	8.8	6.1	3.7	1.4	< 1.0%	< 1.0%	< 1.0%
	J6 (SE1)	J36	2.4	1.7	< 1.0%	< 1.0%	< 1.0%	< 1.0%	< 1.0%

Pin Map (reference Appendix C for full description of test boards)

SE1:

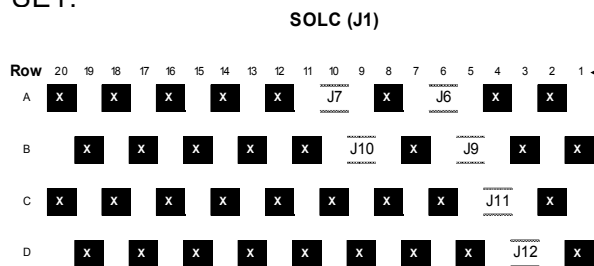

SE2:

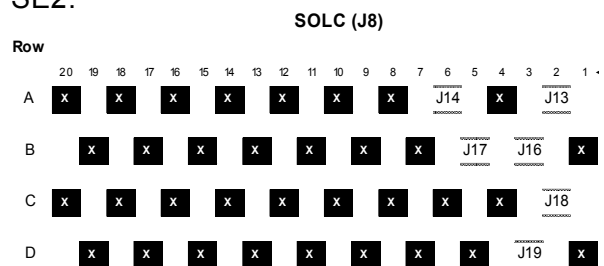

Row

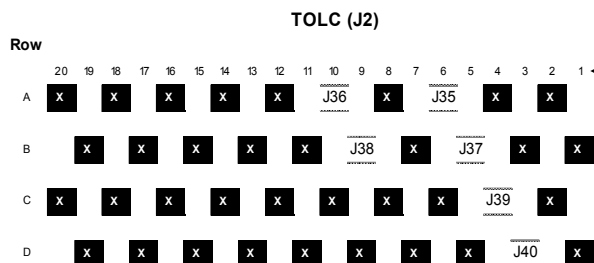

Row

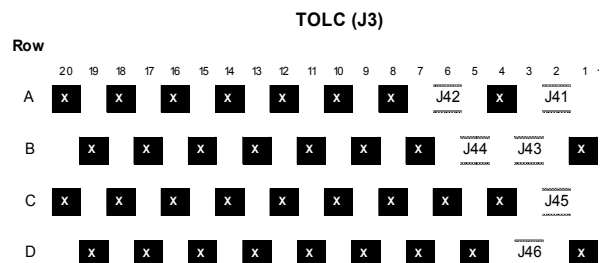

**Series:** TOLC/SOLC, 1.27mm (0.050") Contact Pitch, 0.64mm (0.025") Footprint Pitch  
**Description:**, Board-to-Board, Surface Mount, 6.35mm (0.250") Stack Height

Table 6 - Differential Crosstalk (%)									
Input (t <sub>r</sub> )	Source	Victim	30±5ps	50 ps	100 ps	250 ps	500 ps	750 ps	1 ns
NEXT	J34-J28 (DP2)	J33-J27	4.1	2.9	1.7	< 1.0%	< 1.0%	< 1.0%	< 1.0%
	J21-J24 (DP1)	J25-J26	3.4	2.6	1.9	< 1.0%	< 1.0%	< 1.0%	< 1.0%
	J14-J17 (SE2)	J13-J16	2.6	2.1	1.6	< 1.0%	< 1.0%	< 1.0%	< 1.0%
	J34-J28 (DP2)	J30-J32	3.0	2.1	1.5	< 1.0%	< 1.0%	< 1.0%	< 1.0%
	J21-J24 (DP1)	J20-J23	1.4	< 1.0%	< 1.0%	< 1.0%	< 1.0%	< 1.0%	< 1.0%
FEXT	J34-J28 (DP2)	J53-J55	6.2	3.8	2.2	< 1.0%	< 1.0%	< 1.0%	< 1.0%
	J21-J24 (DP1)	J51-J52	1.7	1.5	< 1.0%	< 1.0%	< 1.0%	< 1.0%	< 1.0%
	J14-J17 (SE2)	J41-J43	2.1	1.0	< 1.0%	< 1.0%	< 1.0%	< 1.0%	< 1.0%
	J34-J28 (DP2)	J58-J60	1.8	1.5	1.0	< 1.0%	< 1.0%	< 1.0%	< 1.0%
	J21-J24 (DP1)	J47-J49	1.4	< 1.0%	< 1.0%	< 1.0%	< 1.0%	< 1.0%	< 1.0%

Pin Map (reference Appendix C for full description of test boards)

DP1:

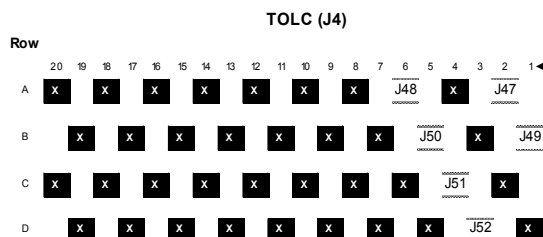
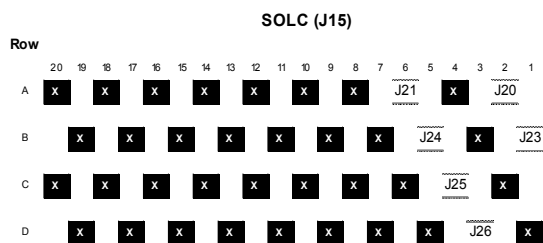

DP2:

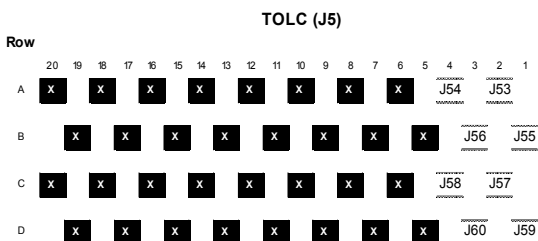
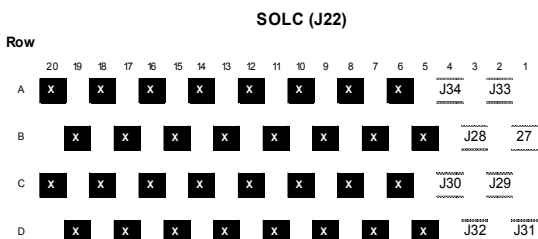

**Series:** TOLC/SOLC, 1.27mm (0.050") Contact Pitch, 0.64mm (0.025") Footprint Pitch  
**Description:**, Board-to-Board, Surface Mount, 6.35mm (0..250") Stack Height

<b>Table 7 - Propagation Delay (Mated Connector)</b>	
<b>Single-Ended</b>	54ps
<b>Differential</b>	50ps

**Series:** TOLC/SOLC, 1.27mm (0.050") Contact Pitch, 0.64mm (0.025") Footprint Pitch  
**Description:**, Board-to-Board, Surface Mount, 6.35mm (0.250") Stack Height

### Characterization Details

This report presents data which characterizes the signal integrity response of a connector pair in a controlled printed circuit board (PCB) environment. All efforts are made to reveal typical best-case responses inherent to the system under test (SUT).

In this report, the SUT includes the test PCB from drive side probe tips to receive side probe tips. PCB effects are not removed or de-embedded from the test data. PCB designs with impedance mismatch, large losses, skew, cross talk, or similar impairments can have a significant impact on observed test data. Therefore, great design effort is put forth to limit these effects in the PCB utilized in these tests. Some board related effects, such as pad-to-ground capacitance and trace loss, are included in the data presented in this report. But other effects, such as via coupling or stub resonance, are not evaluated here. Such effects are addressed and characterized fully by the Samtec [Final Inch®](#) products.

Additionally, intermediate test signal connections can mask the connectors' true performance. Such connection effects are minimized by using high performance test cables, adapters, and microwave probes. Where appropriate, calibration and de-embedding routines are also used to reduce residual effects.

### Differential and Single-Ended Data

Most Samtec connectors can be used successfully in both differential and single-ended applications. However, electrical performance will differ depending on the signal drive type. In this report, data is presented for both differential and single-ended drive scenarios.

### Connector Signal to Ground Ratio

Samtec connectors are most often designed for generic applications, and can be implemented using various signal and ground pin assignments. In high speed systems, provisions must be made in the interconnect for signal return currents. Such paths are often referred to as "ground". In some connectors, a ground plane or blade, or an outer shield is used as the signal return, while in others, connector pins are used as signal returns. Various combinations of signal pins, ground blades, and shields can also be utilized. Electrical performance can vary significantly depending upon the number and location of ground pins.

In general, the more pins dedicated to ground, the better electrical performance will be. But dedicating pins to ground reduces signal density of a connector. So care must be taken when choosing signal/ground ratios in cost- or density-sensitive applications.

**Series:** TOLC/SOLC, 1.27mm (0.050") Contact Pitch, 0.64mm (0.025") Footprint Pitch  
**Description:**, Board-to-Board, Surface Mount, 6.35mm (0.250") Stack Height

For this connector, the following configurations were evaluated (reference Appendix C for full description of test boards):

SE1:

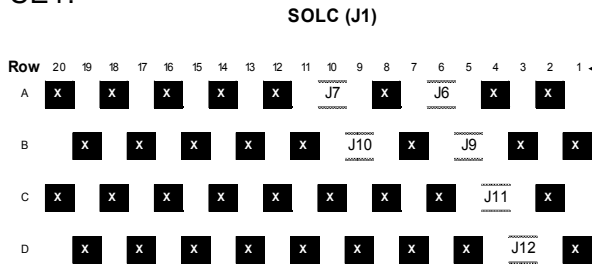

SE2:

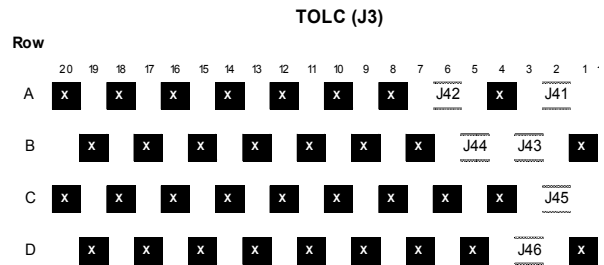
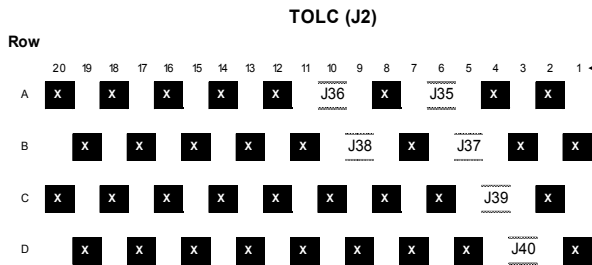
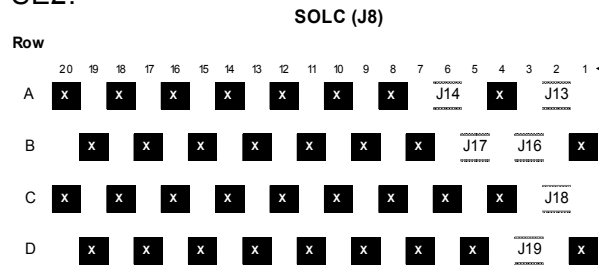

Single-Ended Impedance:

- Well-referenced line (reference SE1)

Single-Ended Crosstalk:

- Well-referenced line; mimics 1:1 S:G ratio (reference SE1)
- 2:1 S:G ratio (reference SE2)

Only one single-ended signal was driven for crosstalk measurements.

**Series:** TOLC/SOLC, 1.27mm (0.050”) Contact Pitch, 0.64mm (0.025”) Footprint Pitch  
**Description:**, Board-to-Board, Surface Mount, 6.35mm (0.250”) Stack Height

DP1:

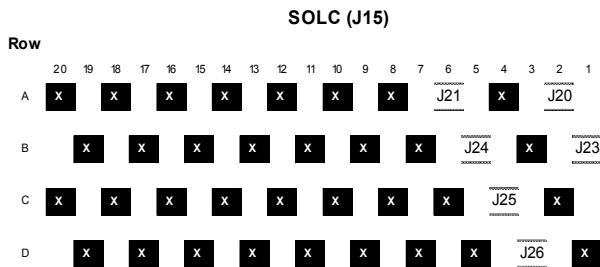

DP2:

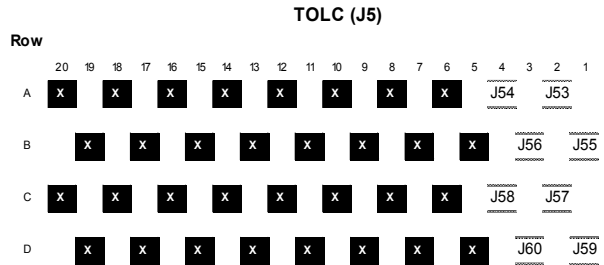
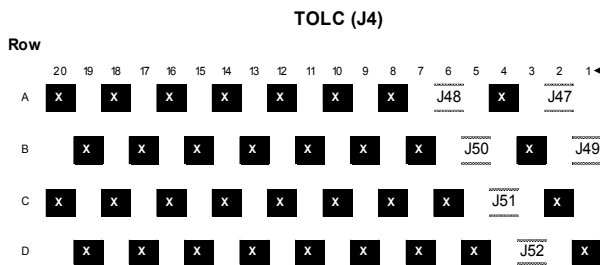
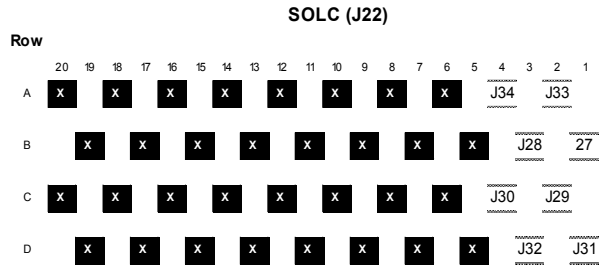

Differential Impedance:

- Well-referenced line (reference DP1)

Differential Crosstalk:

- Well-referenced line; mimics 1:1 S:G ratio (reference DP1)
- Higher Signal Density (reference SE2)
- Full-Column Differential (reference DP2)

Only one differential pair was driven for crosstalk measurements.

Other configurations can be evaluated upon request. Please contact [sig@samtec.com](mailto:sig@samtec.com) for more information.

In a real system environment, active signals might be located at the outer edges of the signal contacts of concern, as opposed to the ground signals utilized in laboratory testing. For example, in a single-ended system, a pin-out of “SSSS”, or four adjacent single ended signals, might be encountered, as opposed to the “GSG” and “GSSG” configurations tested in the laboratory. Electrical characteristics in such applications could vary slightly from laboratory results. But in most applications, performance can safely be considered equivalent.

**Series:** TOLC/SOLC, 1.27mm (0.050") Contact Pitch, 0.64mm (0.025") Footprint Pitch  
**Description:**, Board-to-Board, Surface Mount, 6.35mm (0.250") Stack Height

### Signal Edge Speed (Rise Time):

In pulse signaling applications, the perceived performance of an interconnect can vary significantly depending on the edge rate or rise time of the exciting signal. For this report, the fastest rise time used was 30 +/-5 ps. Generally, this should demonstrate worst case performance.

In many systems, the signal edge rate will be significantly slower at the connector than at the driver launch point. To estimate interconnect performance at other edge rates, data is provided for several rise times between 30 ps and 1.0 ns.

For this report, rise times were measured at 10%-90% signal levels.

### **Frequency Domain Data**

Frequency domain parameters are helpful in evaluating the connector system's signal loss and crosstalk characteristics across a range of sinusoidal frequencies. In this report, parameters presented in the frequency domain are insertion loss, return loss, and near-end and far-end crosstalk. Other parameters or formats, such as VSWR or S-parameters, may be available upon request. Please contact our Signal Integrity Group at [sig@samtec.com](mailto:sig@samtec.com) for more information.

Frequency performance characteristics for the SUT are generated from time domain measurements using Fourier Transform calculations. Procedures and methods used in generating the SUT's frequency domain data are provided in the frequency domain test procedures in [Appendix E](#) of this report.

### **Time Domain Data**

Time Domain parameters indicate impedance mismatch versus length, signal propagation time, and crosstalk in a pulsed signal environment. Time Domain data is provided in [Appendix E](#) of this report. Parameters or formats not included in this report may be available upon request. Please contact our Signal Integrity Group at [sig@samtec.com](mailto:sig@samtec.com) for more information.

Reference plane impedance is 50 ohms for single-ended measurements and 100 ohms for differential measurements. The fastest risetime signal exciting the SUT is 30 ± 5 picoseconds.

In this report, propagation delay is defined as the signal propagation time through the PCB connector pads and connector pair. It does not include PCB traces. Delay is measured at 30 ± 5 picoseconds signal risetime. Delay is calculated as the difference in time measured between the 50% amplitude levels of the input and output pulses.

**Series:** TOLC/SOLC, 1.27mm (0.050") Contact Pitch, 0.64mm (0.025") Footprint Pitch  
**Description:**, Board-to-Board, Surface Mount, 6.35mm (0.250") Stack Height

Crosstalk or coupled noise data is provided for various signal configurations. All measurements are single disturber. Crosstalk is calculated as a ratio of the input line voltage to the coupled line voltage. The input line is sometimes described as the active or drive line. The coupled line is sometimes described as the quiet or victim line. Crosstalk ratio is tabulated in this report as a percentage. Measurements are made at both the near-end and far-end of the SUT.

Data for other configurations may be available. Please contact our Signal Integrity Group at [sig@samtec.com](mailto:sig@samtec.com) for further information.

As a rule of thumb, 10% crosstalk levels are often used as a general first pass limit for determining acceptable interconnect performance. But modern system crosstalk tolerance can vary greatly. For advice on connector suitability for specific applications, please contact our Signal Integrity Group at [sig@samtec.com](mailto:sig@samtec.com).

Additional information concerning test conditions and procedures is located in the appendices of this report. Further information may be obtained by contacting our Signal Integrity Group at [sig@samtec.com](mailto:sig@samtec.com).

**Series:** TOLC/SOLC, 1.27mm (0.050") Contact Pitch, 0.64mm (0.025") Footprint Pitch  
**Description:**, Board-to-Board, Surface Mount, 6.35mm (0.250") Stack Height

## Appendix A – Frequency Domain Response Graphs

### Single-Ended Application – Insertion Loss

PCB/Connector Test System  
Single Ended Application  
SOLC/TOLC Quad Row Series

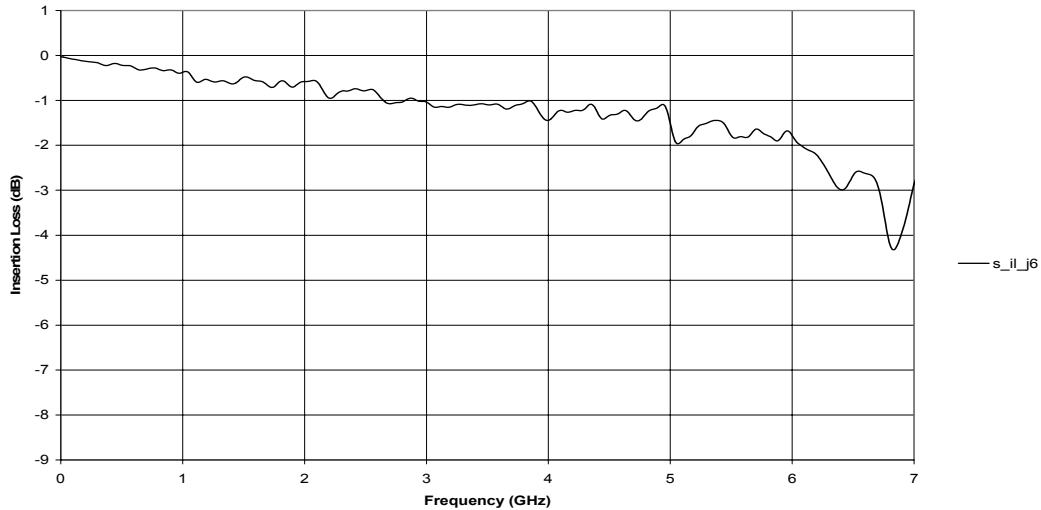

### Single-Ended Application – Return Loss

PCB/Connector Test System  
Single Ended Application  
SOLC/TOLC Quad Row Series

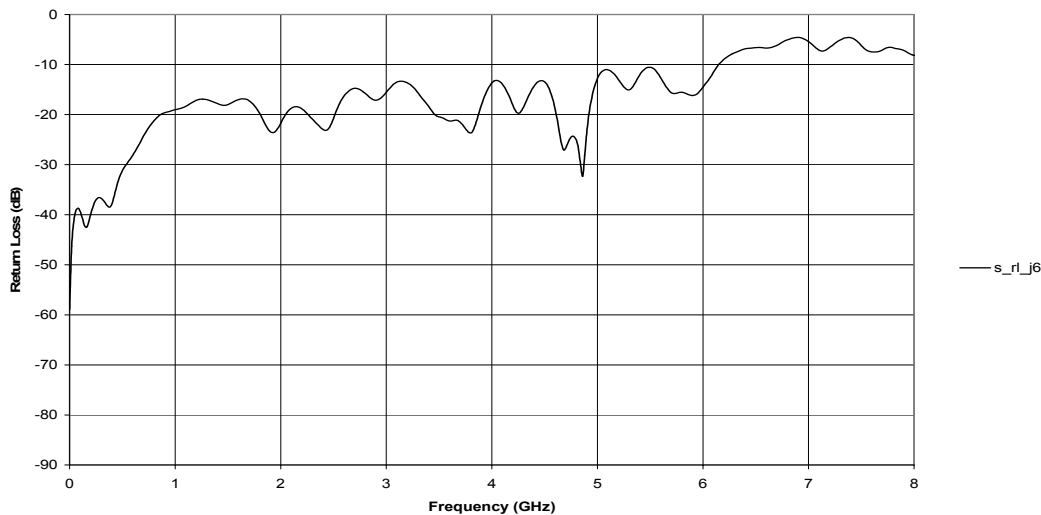

**Series:** TOLC/SOLC, 1.27mm (0.050") Contact Pitch, 0.64mm (0.025") Footprint Pitch  
**Description:**, Board-to-Board, Surface Mount, 6.35mm (0.250") Stack Height

## Single-Ended Application – NEXT

**PCB/Connector Test System  
 Single Ended Application  
 SOLC/TOLC Quad Row Series**

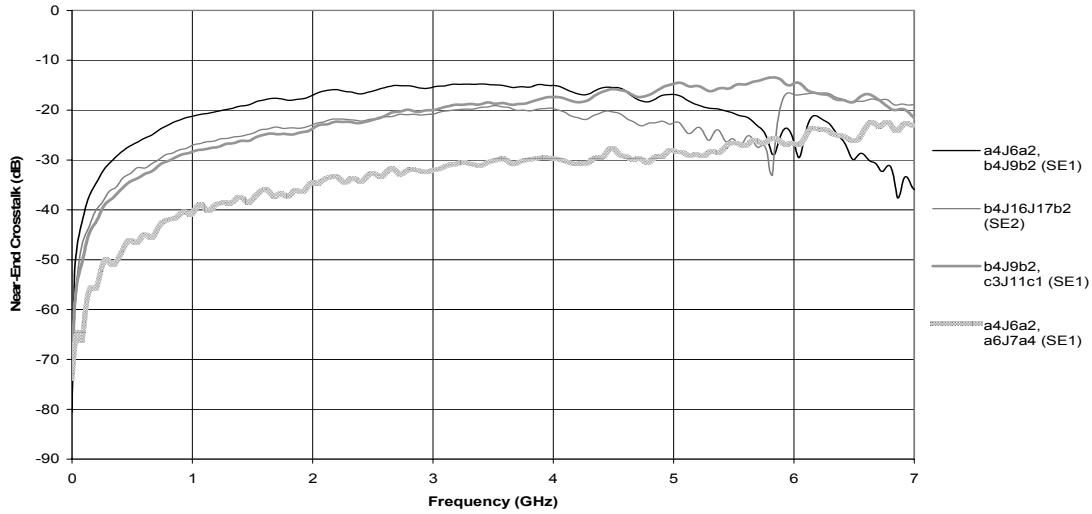

## Single-Ended Application – FEXT

**PCB/Connector Test System  
 Single Ended Application  
 SOLC/TOLC Quad Row Series**

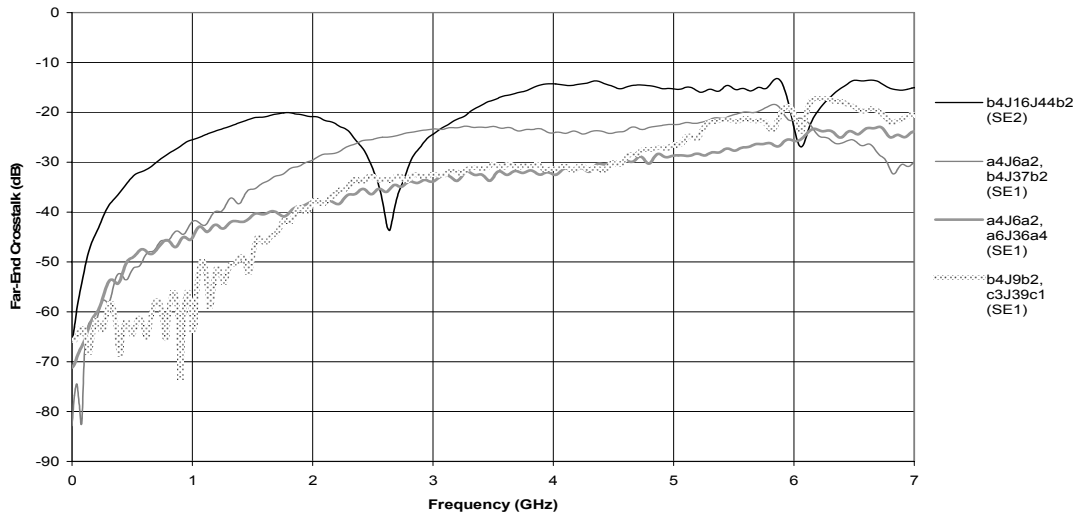

**Series:** TOLC/SOLC, 1.27mm (0.050") Contact Pitch, 0.64mm (0.025") Footprint Pitch  
**Description:**, Board-to-Board, Surface Mount, 6.35mm (0.250") Stack Height

## Differential Application – Insertion Loss

**PCB/Connector Test System  
Differential Application  
SOLC/TOLC Quad Row Series**

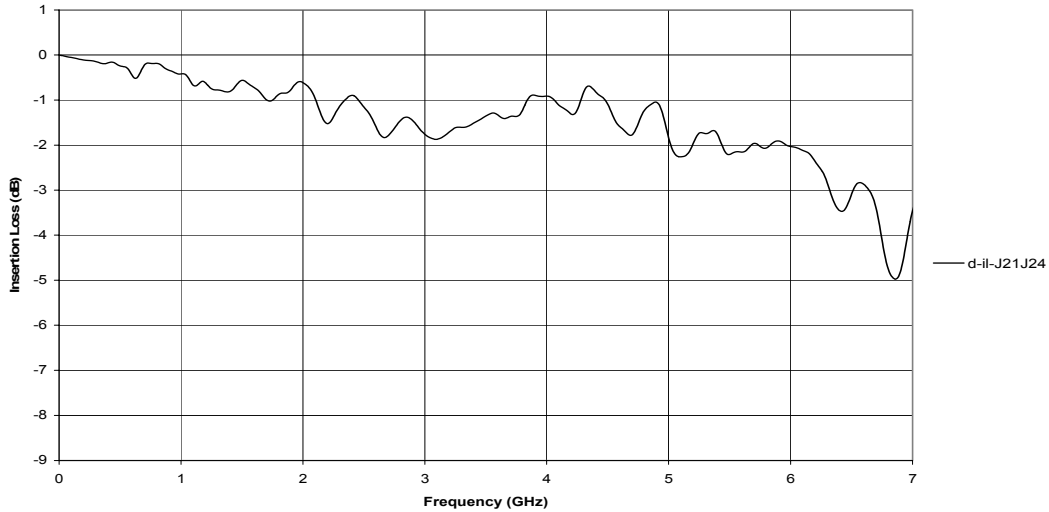

## Differential Application – Return Loss

**PCB/Connector Test System  
Differential Application  
SOLC/TOLC Quad Row Series**

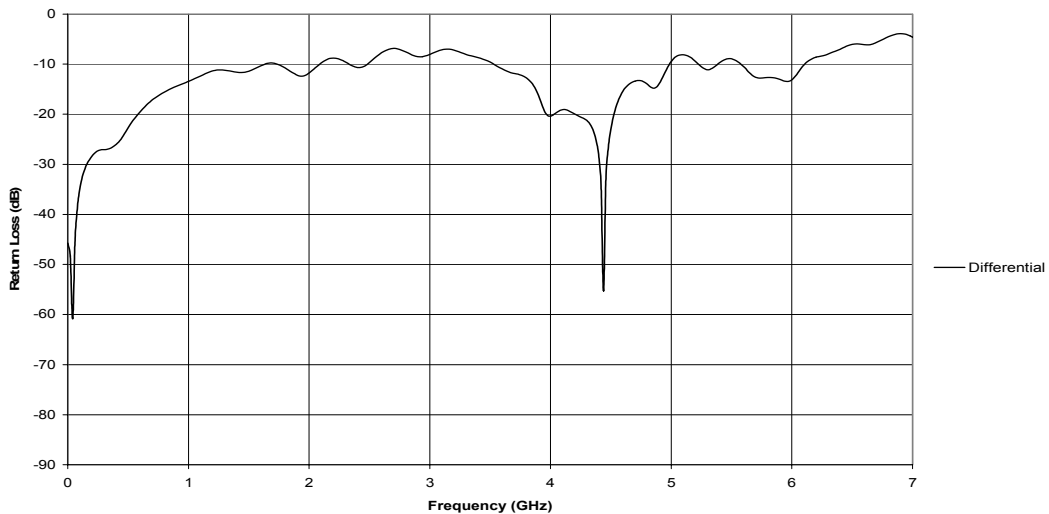

**Series:** TOLC/SOLC, 1.27mm (0.050") Contact Pitch, 0.64mm (0.025") Footprint Pitch  
**Description:**, Board-to-Board, Surface Mount, 6.35mm (0.250") Stack Height

## Differential Application – NEXT

**PCB/Connector Test System  
 Differential Application  
 SOLC/TOLC Quad Row Series**

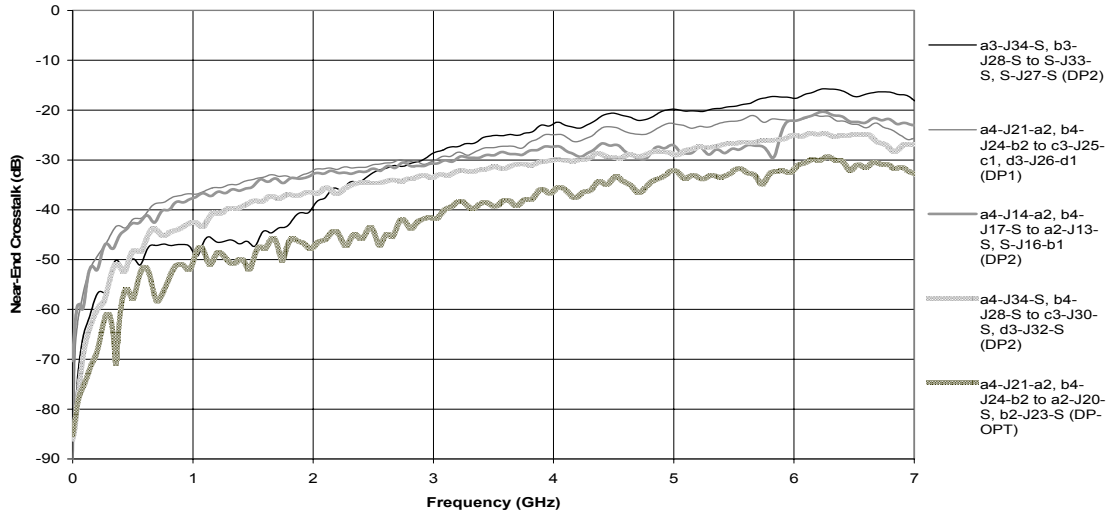

## Differential Application – FEXT

**PCB/Connector Test System  
 Differential Application  
 SOLC/TOLC Quad Row Series**

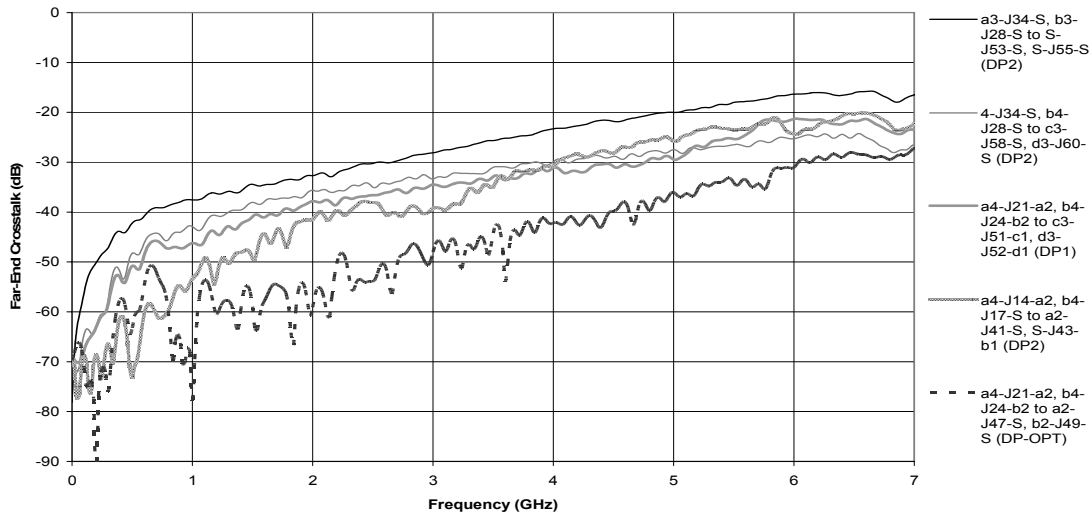

**Series:** TOLC/SOLC, 1.27mm (0.050") Contact Pitch, 0.64mm (0.025") Footprint Pitch  
**Description:**, Board-to-Board, Surface Mount, 6.35mm (0.250") Stack Height

## Appendix B – Time Domain Response Graphs

### Single-Ended Application – Input Pulse

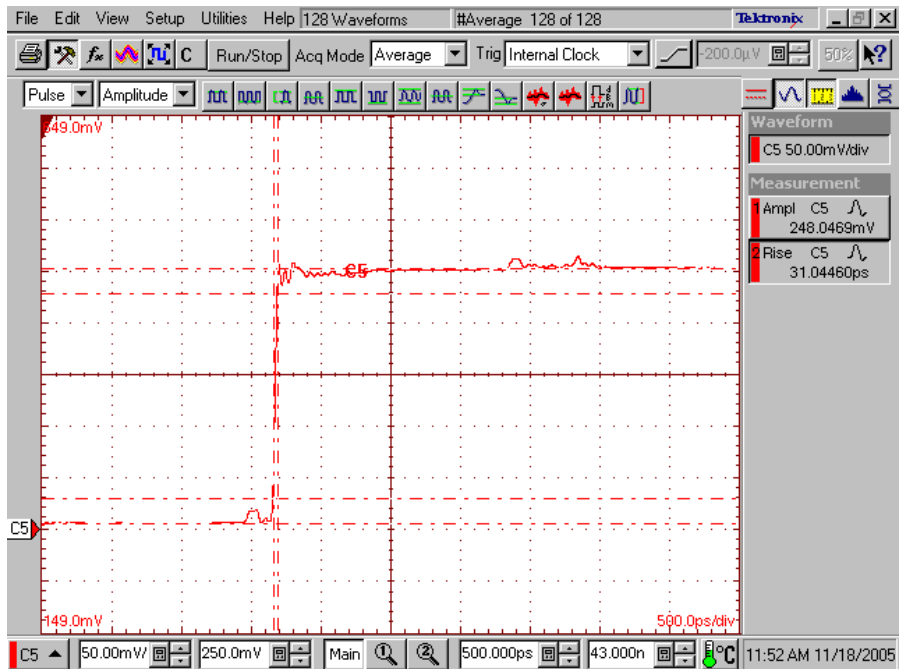

**Series:** TOLC/SOLC, 1.27mm (0.050") Contact Pitch, 0.64mm (0.025") Footprint Pitch  
**Description:**, Board-to-Board, Surface Mount, 6.35mm (0.250") Stack Height

## Single-Ended Application – Impedance

Configuration: (Source = SOLC J6)



## Single-Ended Application – Propagation Delay

Configuration: (Source – SOLC J6)

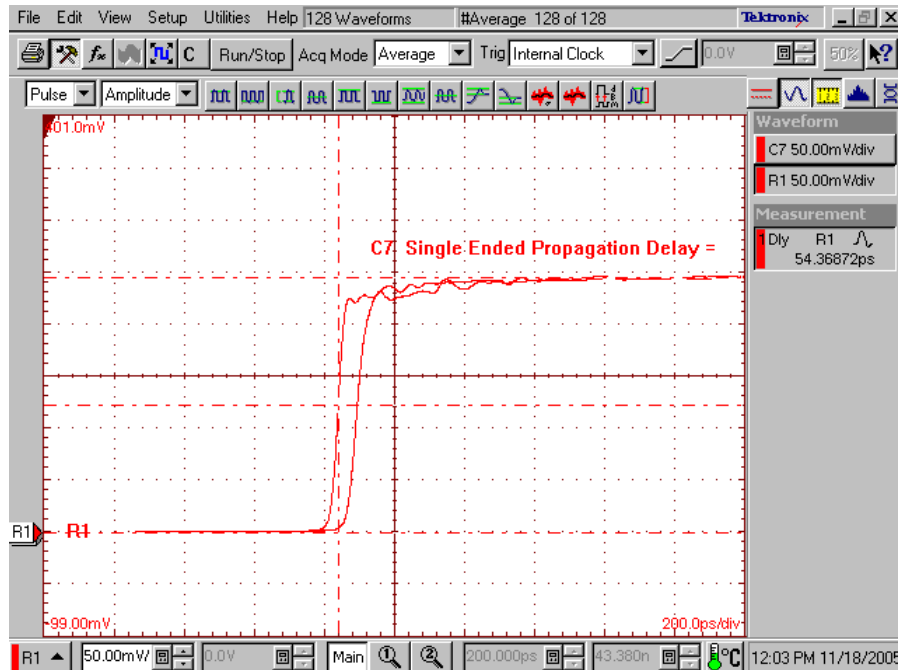

**Series:** TOLC/SOLC, 1.27mm (0.050") Contact Pitch, 0.64mm (0.025") Footprint Pitch  
**Description:**, Board-to-Board, Surface Mount, 6.35mm (0.250") Stack Height

## Single-Ended Application – NEXT

Configuration: (SE1: Source = SOLC J6; Victim = SOLC J9)

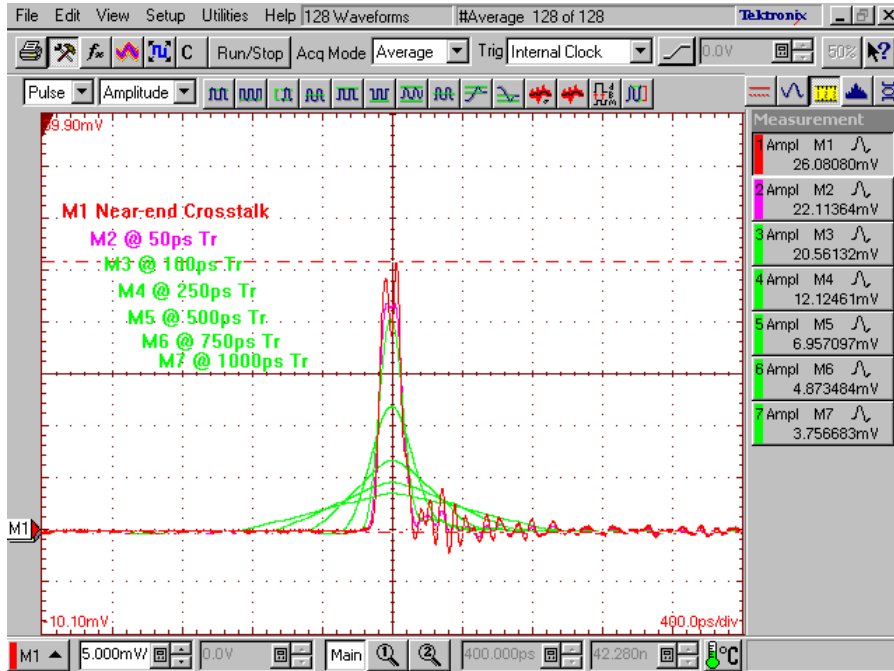

## Single-Ended Application – FEXT

Configuration: (SE1: Source = SOLC J6; Victim = TOLC J37)



**Series:** TOLC/SOLC, 1.27mm (0.050") Contact Pitch, 0.64mm (0.025") Footprint Pitch  
**Description:**, Board-to-Board, Surface Mount, 6.35mm (0.250") Stack Height

## Single-Ended Application – NEXT

Configuration: (SE2: Source = SOLC J16; Victim = SOLC J17)

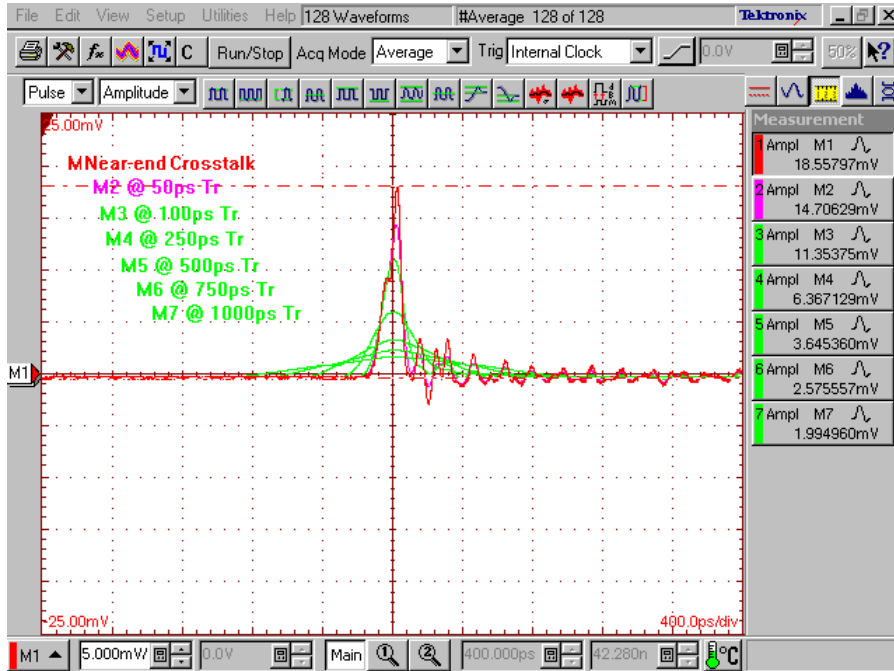

## Single-Ended Application – FEXT

Configuration: (SE2: Source = SOLC J16; Victim = TOLC J44)

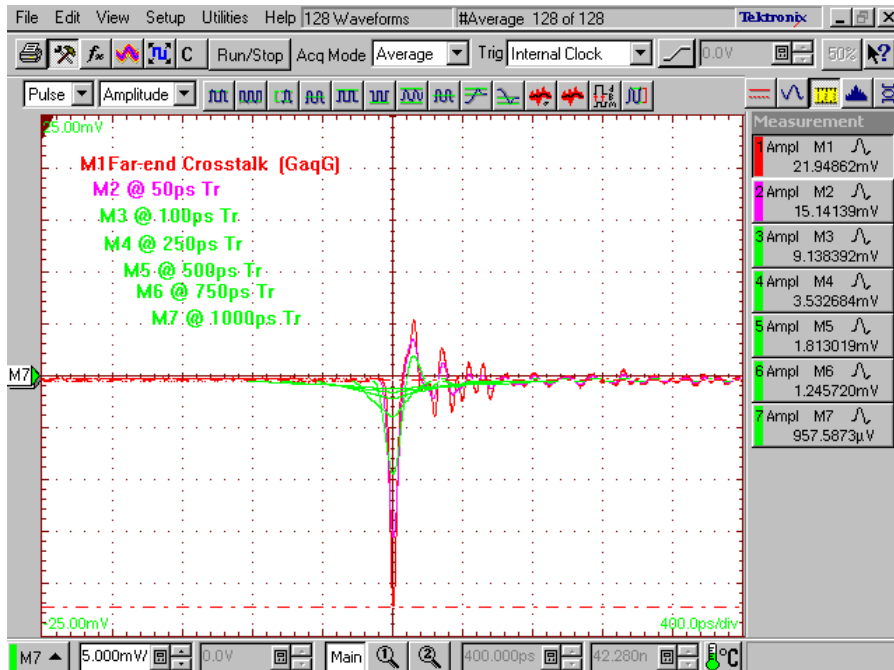

**Series:** TOLC/SOLC, 1.27mm (0.050") Contact Pitch, 0.64mm (0.025") Footprint Pitch  
**Description:**, Board-to-Board, Surface Mount, 6.35mm (0.250") Stack Height

## Single-Ended Application – NEXT

Configuration: (SE1: Source = SOLC J9; Victim = SOLC J11)

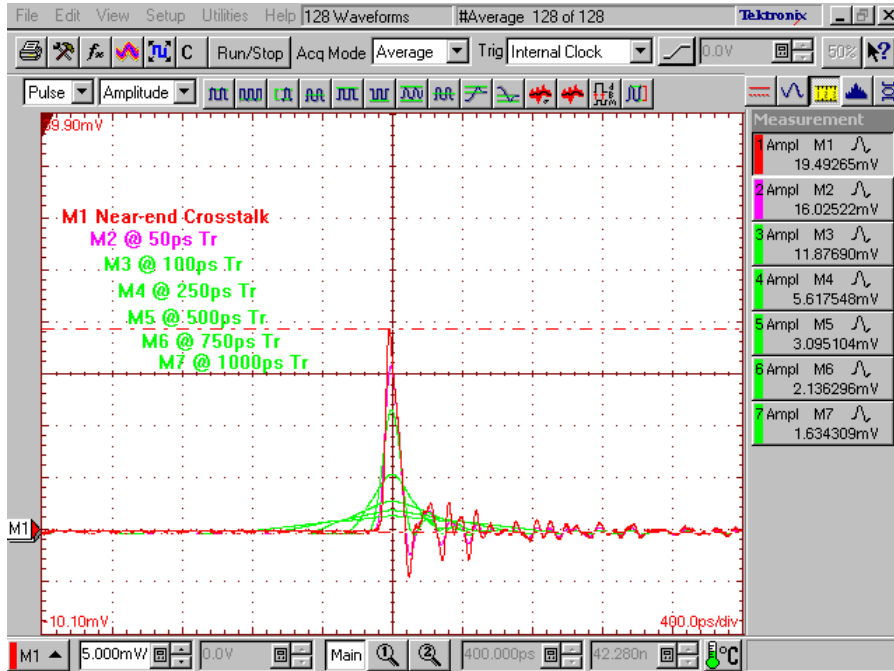

## Single-Ended Application – FEXT

Configuration: (SE1: Source = SOLC J9; Victim = TOLC J39)



**Series:** TOLC/SOLC, 1.27mm (0.050") Contact Pitch, 0.64mm (0.025") Footprint Pitch  
**Description:**, Board-to-Board, Surface Mount, 6.35mm (0.250") Stack Height

## Single-Ended Application – NEXT

Configuration: (SE1: Source = SOLC J6; Victim = SOLC J7)

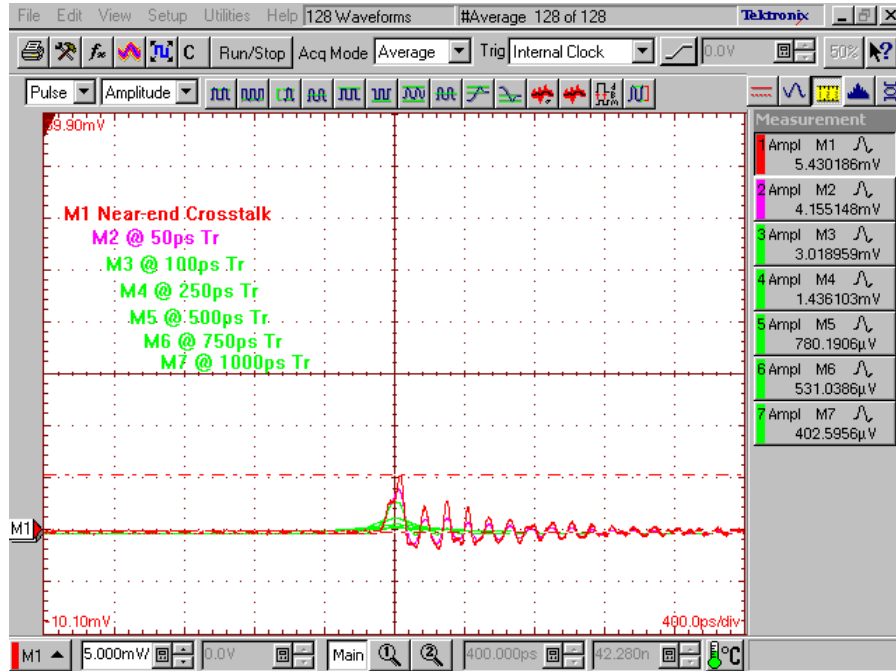

## Single-Ended Application – FEXT

Configuration: (SE1: Source = SOLC J6; Victim = SOLC J36)

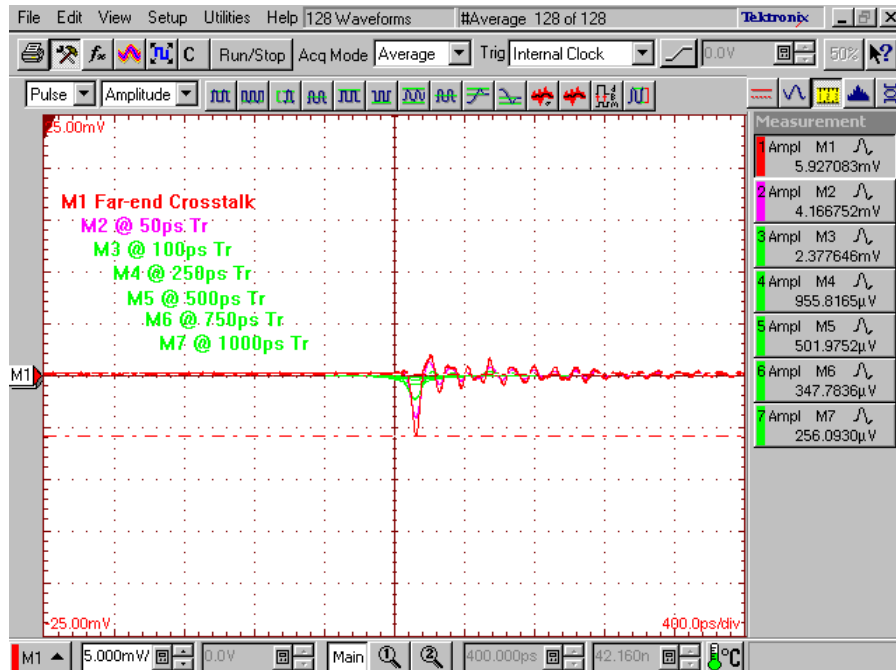

**Series:** TOLC/SOLC, 1.27mm (0.050") Contact Pitch, 0.64mm (0.025") Footprint Pitch  
**Description:**, Board-to-Board, Surface Mount, 6.35mm (0.250") Stack Height

## Differential Application – Input Pulse

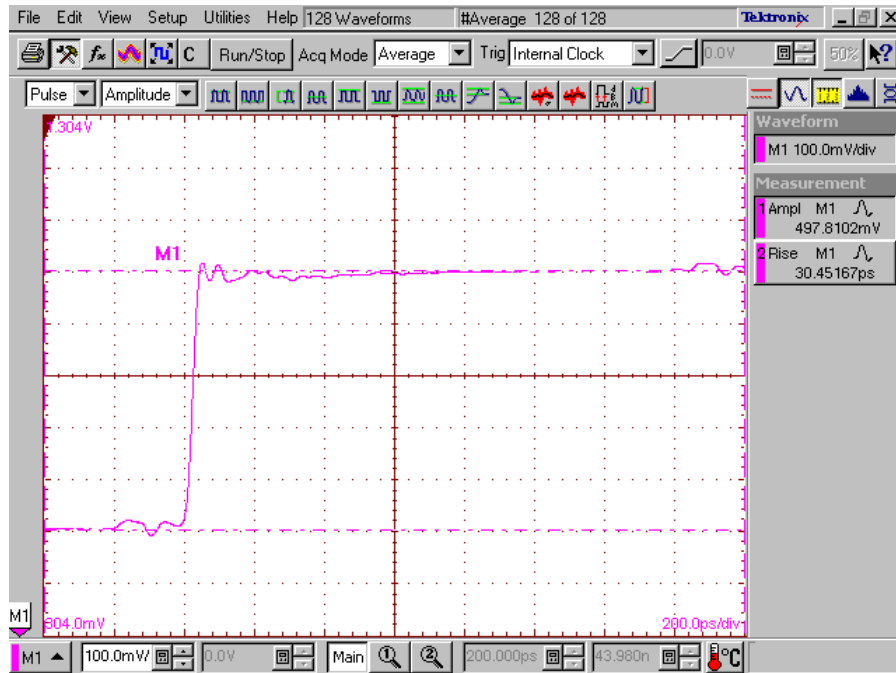

**Series:** TOLC/SOLC, 1.27mm (0.050") Contact Pitch, 0.64mm (0.025") Footprint Pitch  
**Description:**, Board-to-Board, Surface Mount, 6.35mm (0.250") Stack Height

## Differential Application – Impedance

Configuration: (DP1: Source = SOLC J21-J24)

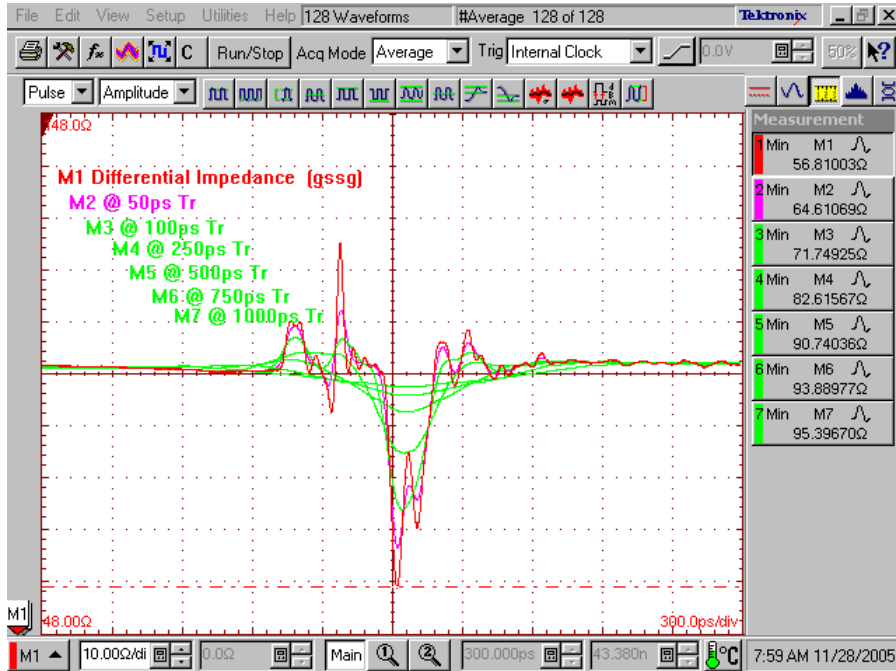

## Differential Application – Propagation Delay

Configuration: (SE2: Source = SOLC J14-J17)

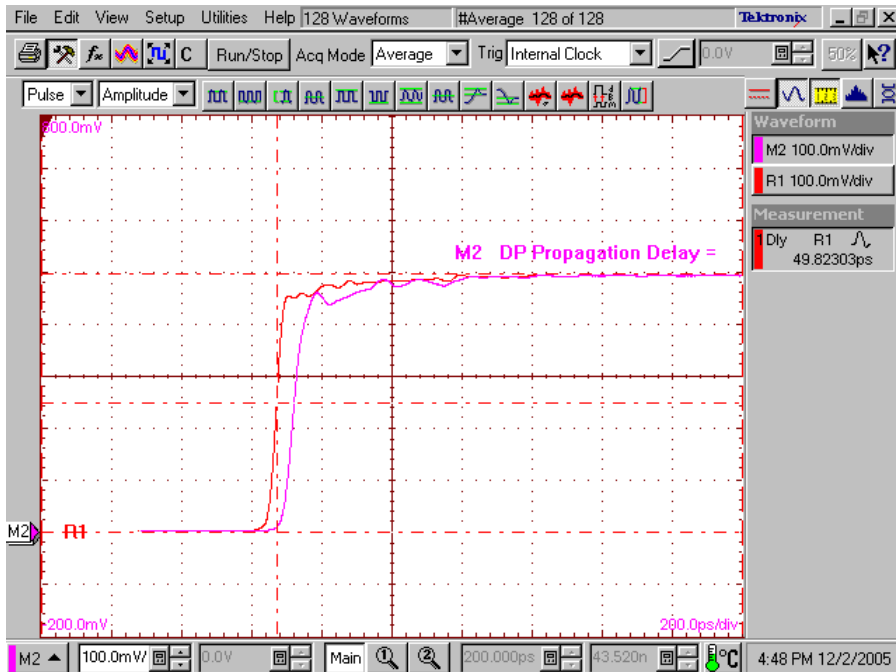

**Series:** TOLC/SOLC, 1.27mm (0.050") Contact Pitch, 0.64mm (0.025") Footprint Pitch  
**Description:**, Board-to-Board, Surface Mount, 6.35mm (0.250") Stack Height

## Differential Application – NEXT

Configuration: (DP2: Source = SOLC J34-J28; Victim = SOLC J33-J27)

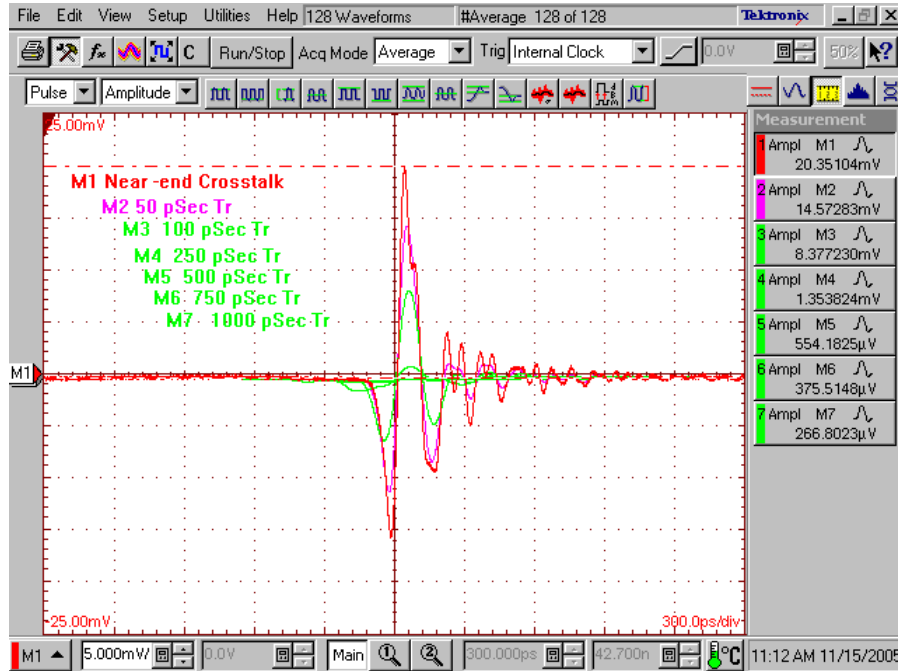

## Differential Application – FEXT

Configuration: (DP2: Source = SOLC J34-J28; Victim = TOLC J53-J55)



**Series:** TOLC/SOLC, 1.27mm (0.050") Contact Pitch, 0.64mm (0.025") Footprint Pitch  
**Description:**, Board-to-Board, Surface Mount, 6.35mm (0.250") Stack Height

## Differential Application – NEXT

Configuration: (DP2: Source = SOLC J34-J28; Victim = SOLC J30-J32)

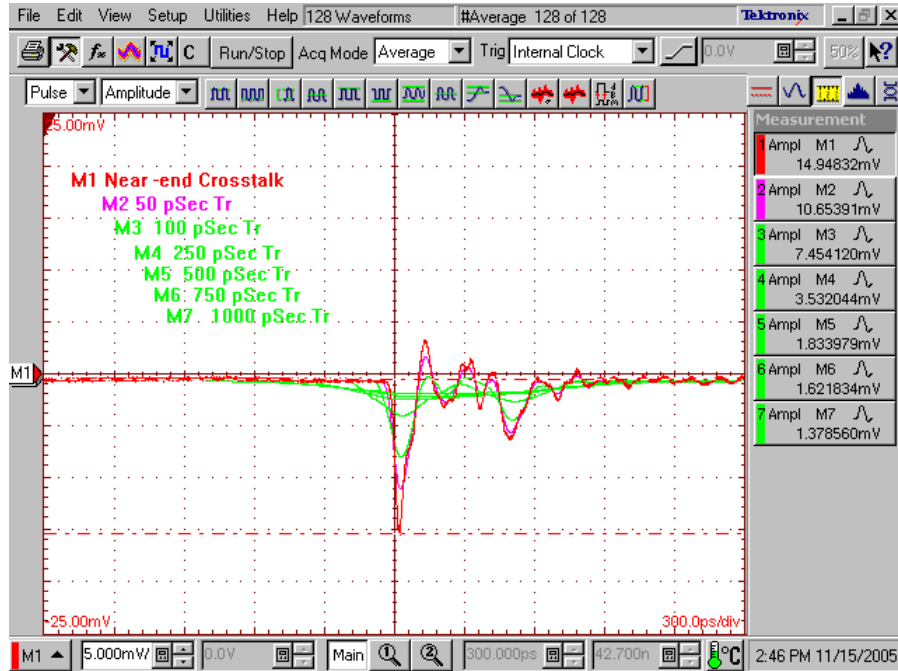

## Differential Application – FEXT

Configuration: (DP2: Source = SOLC J34-J28; Victim = TOLC J58-J60)

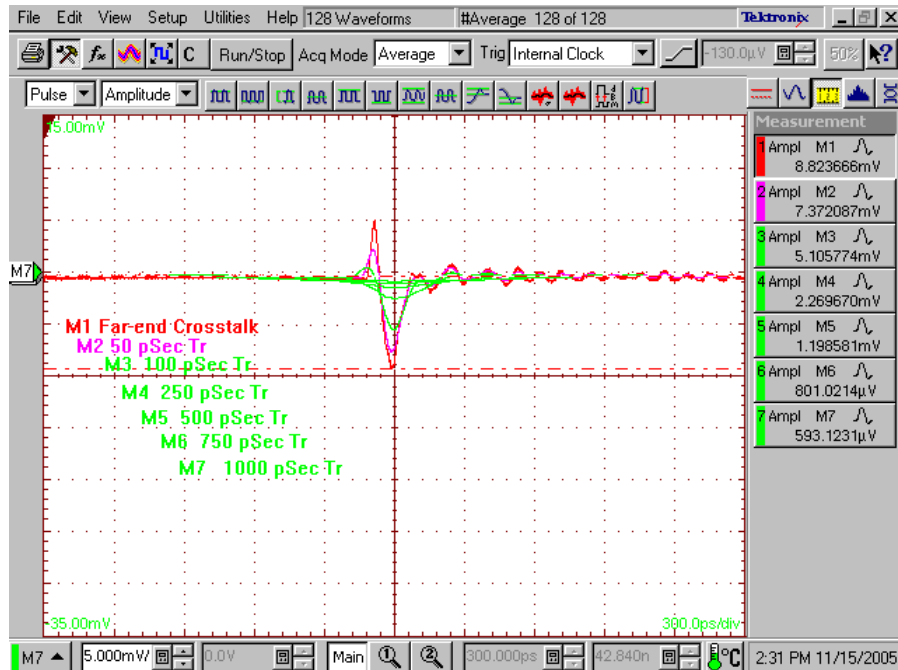

**Series:** TOLC/SOLC, 1.27mm (0.050") Contact Pitch, 0.64mm (0.025") Footprint Pitch  
**Description:**, Board-to-Board, Surface Mount, 6.35mm (0.250") Stack Height

## Differential Application – NEXT

Configuration: (DP1: Source = SOLC J21-J24; Victim = SOLC J25-J26)

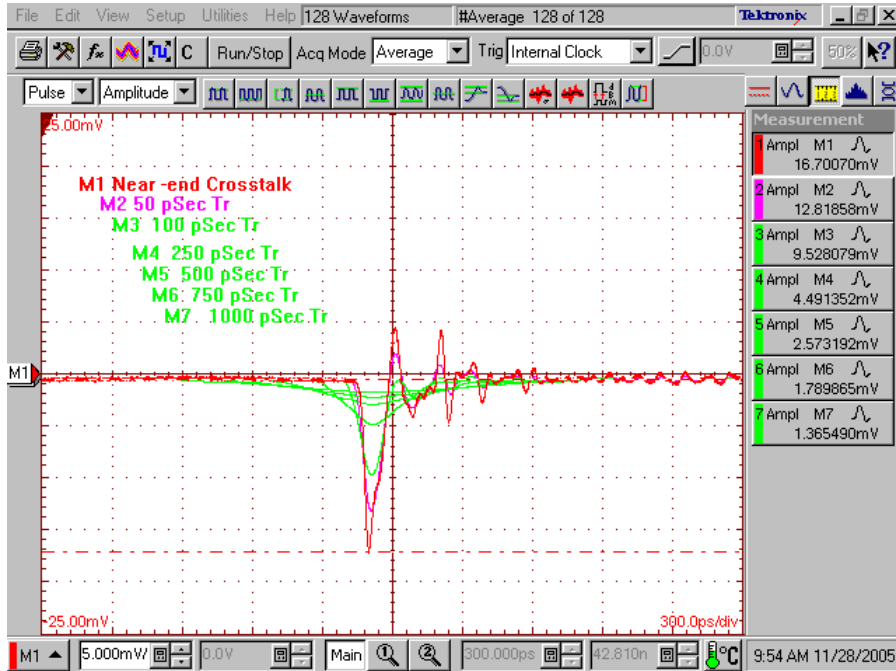

## Differential Application – FEXT

Configuration: (DP1: Source = SOLC J21-J24; Victim = TOLC J51-J52)

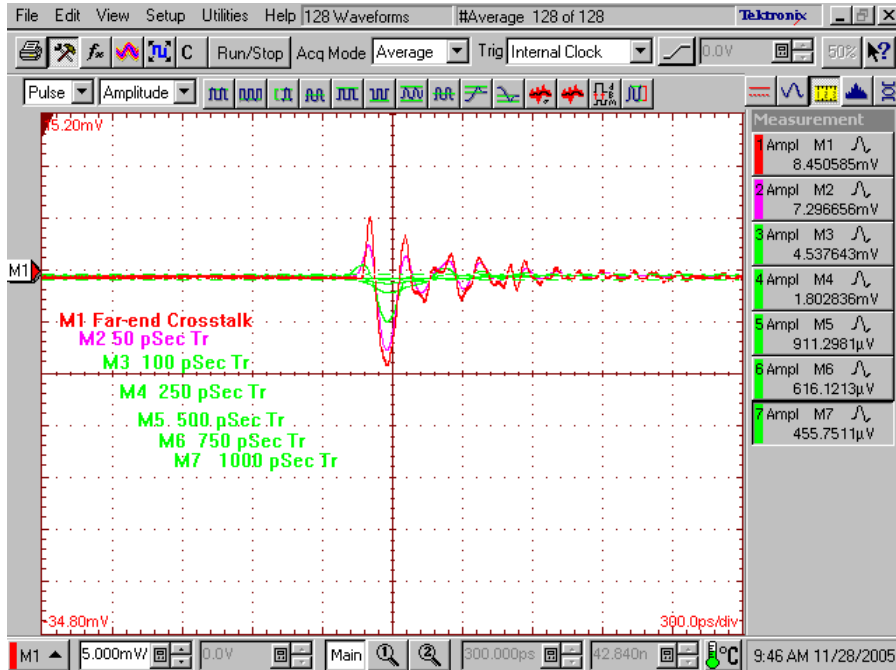

**Series:** TOLC/SOLC, 1.27mm (0.050") Contact Pitch, 0.64mm (0.025") Footprint Pitch  
**Description:**, Board-to-Board, Surface Mount, 6.35mm (0.250") Stack Height

## Differential Application – NEXT

Configuration: (SE2: Source = SOLC J14-J17; Victim = SOLC J13-J16)

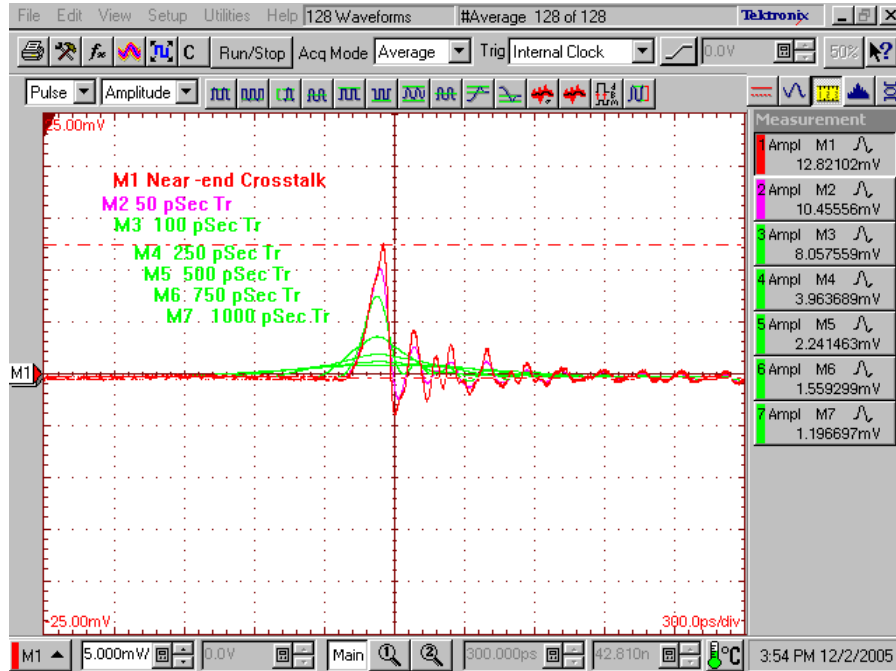

## Differential Application – FEXT

Configuration: (SE2: Source = SOLC J14-J17; Victim = TOLC J41-J43)

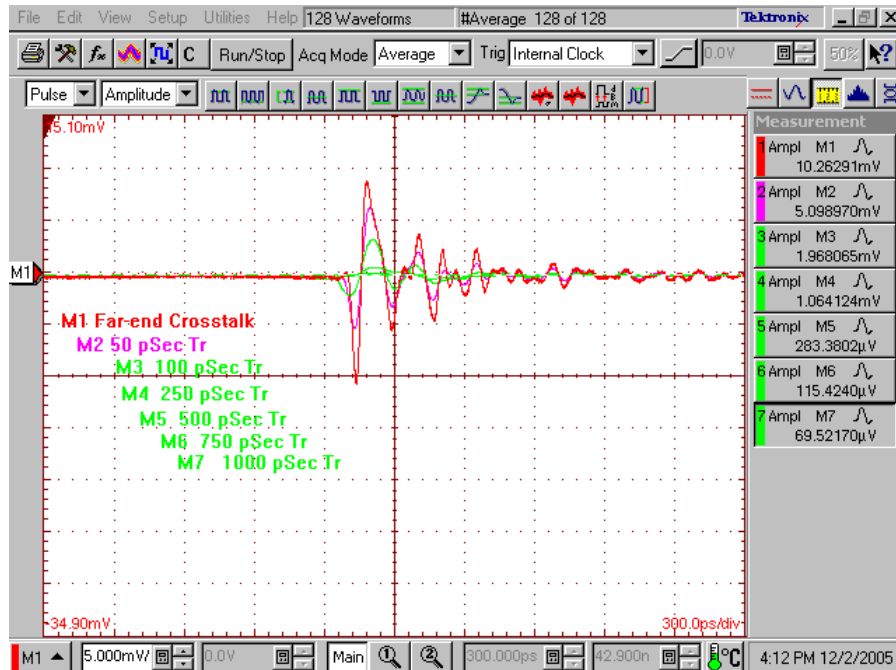

**Series:** TOLC/SOLC, 1.27mm (0.050") Contact Pitch, 0.64mm (0.025") Footprint Pitch  
**Description:**, Board-to-Board, Surface Mount, 6.35mm (0.250") Stack Height

## Differential Application – NEXT

Configuration: (DP1: Source = SOLC J21-J24; Victim = SOLC J20-J23)

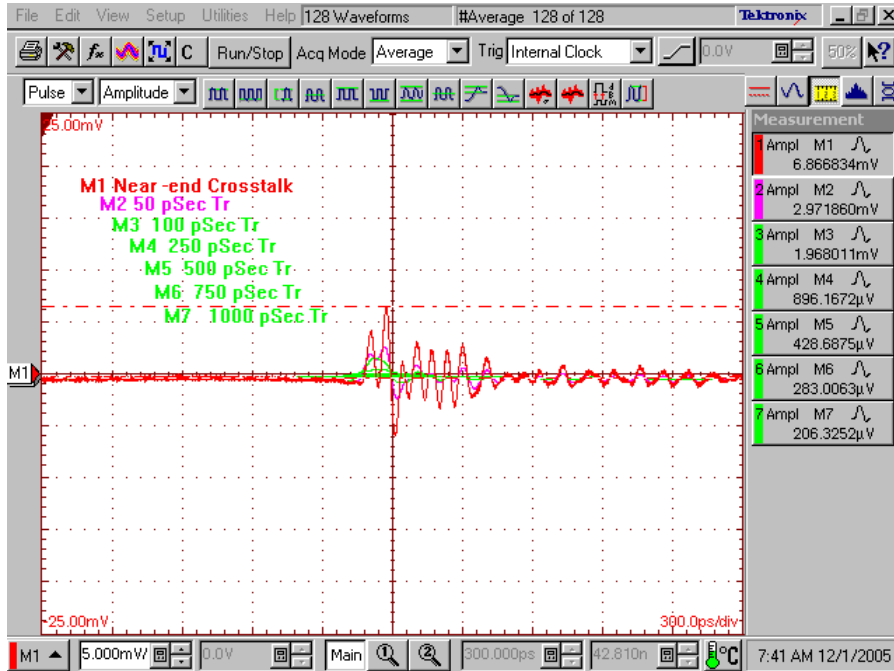

## Differential Application – FEXT

Configuration: (DP1: Source = SOLC J21-J24; Victim = TOLC J47-J49)

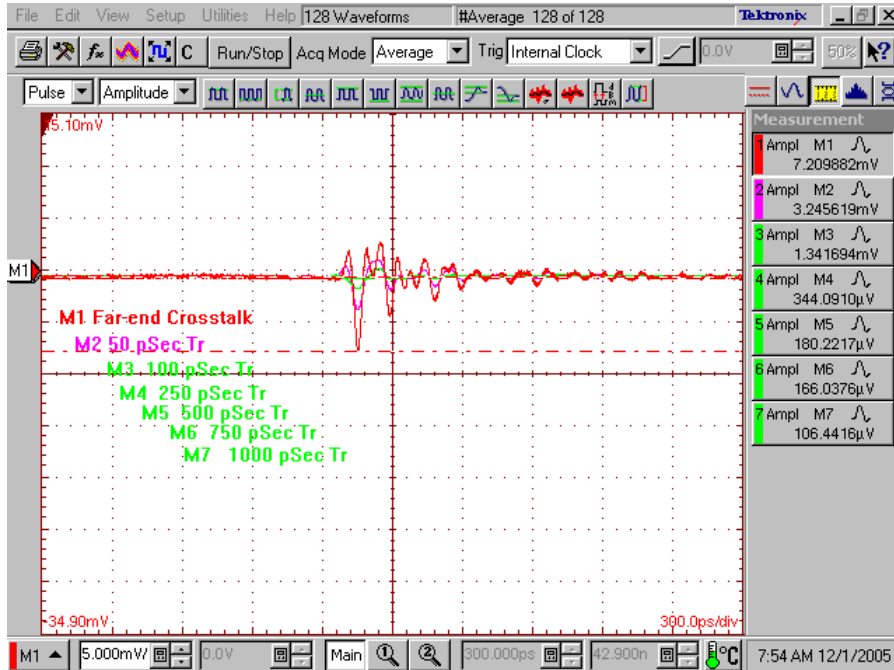

**Series:** TOLC/SOLC, 1.27mm (0.050") Contact Pitch, 0.64mm (0.025") Footprint Pitch  
**Description:**, Board-to-Board, Surface Mount, 6.35mm (0.250") Stack Height

## Appendix C – Product and Test System Descriptions

### Product Description

Product samples are a staggered quad row connector system. The SOLC socket and TOLC terminal mating system is described by P/N SOLC-110-02-S-Q-LC and P/N TOLC-110-02-S-Q-LC respectively. When mated a board-to-board stack height of 6.35mm (0.250") exists between boards. Connector structures consist of 4 rows of 10 contact positions mounted into a plastic housing in a surface mount design. Staggered mating contacts are on a 1.27mm center (.050") pitch. Surface mount terminals lay 20 to a row on a 0.64mm (.025") pitch.

### Test System Description

The test fixtures are composed of a 4-layer FR-4 material with 50Ω and 100Ω signal traces launched from a board mount vertical RF SMA(f) coaxial connector used for the electrical characterization of Samtec hi-speed connector products. The pictured fixtures are specific to the SOLC/TOLC series connector and are identified by Samtec P/N PCB-100364-TST-01 and P/N PCB-100364-TST-02 (Figure 1)

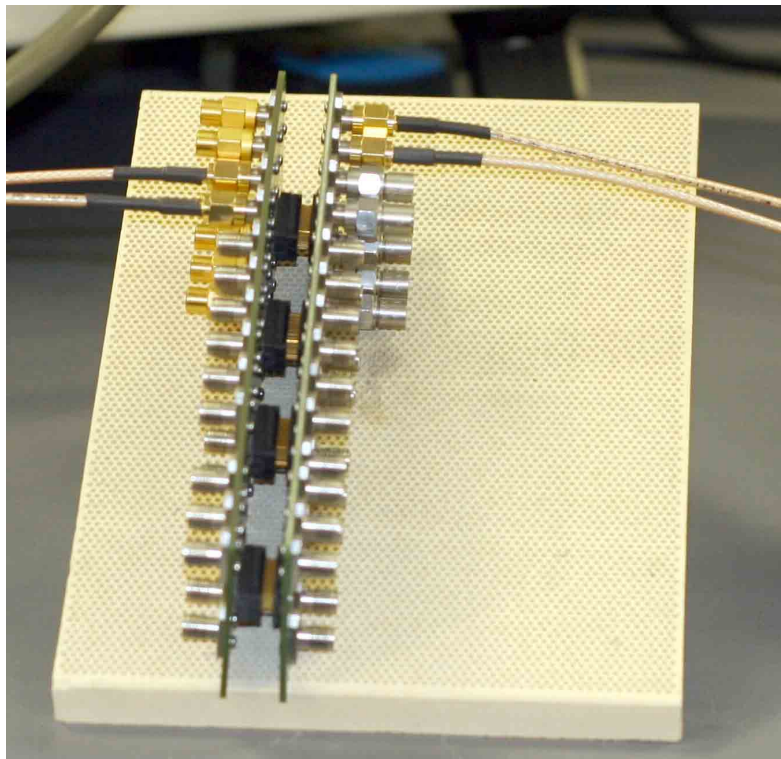
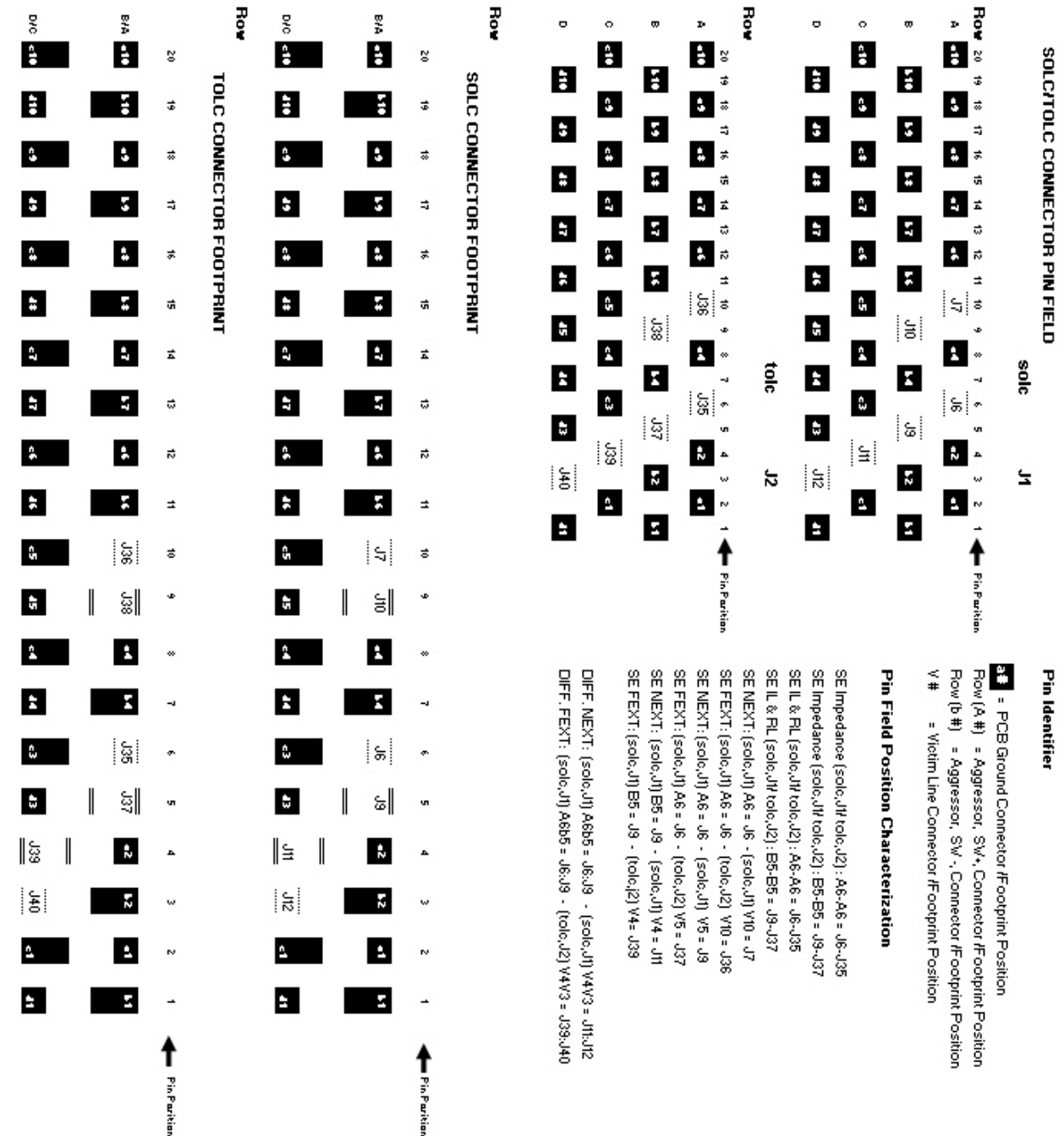

**Figure 1 Mated PCB Test Fixtures with Mounted Test Connectors**



**Series:** TOLC/SOLC, 1.27mm (0.050") Contact Pitch, 0.64mm (0.025") Footprint Pitch  
**Description:**, Board-to-Board, Surface Mount, 6.35mm (0.250") Stack Height

## SOLC, J1 / TOLC, J2 Connector/Footprint Pinout Map (SE1)



**Series:** TOLC/SOLC, 1.27mm (0.050") Contact Pitch, 0.64mm (0.025") Footprint Pitch  
**Description:**, Board-to-Board, Surface Mount, 6.35mm (0.250") Stack Height

## SOLC, J8 / TOLC, J3 Connector/Footprint Pinout Map (SE2)

Fixture Description: Mate single SOLC connector J8 to J3 on multiple TOLC connector PCB-100364-TST-02

### SOLC/TOLC CONNECTOR PIN FIELD

#### SOLC J8

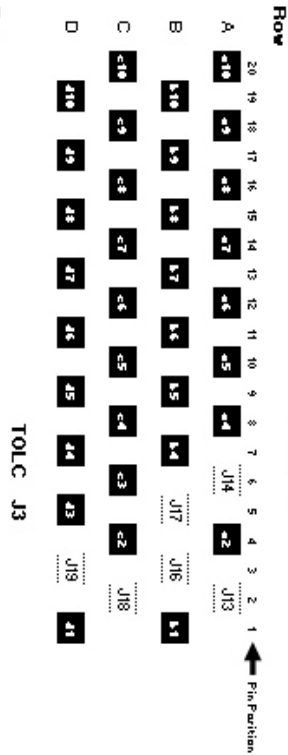

#### TOLC J3

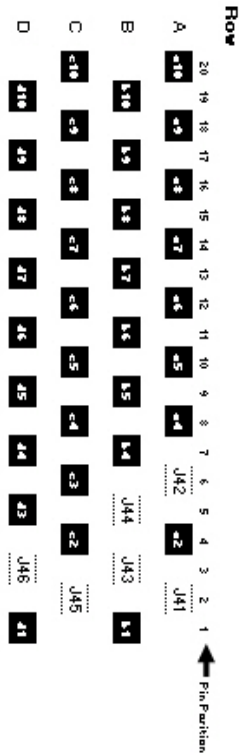

### Pin Identifier

- A#** = PCB Ground Connector /Footprint Position
- Row (A #) = Aggressor, SW+, Connector /Footprint Position
- Row (b #) = Aggressor, SW-, Connector /Footprint Position
- V # = Victim Line Connector /Footprint Position

### Pin Field Position Characterization

- SE Impedance (solc,J8 /tolc,J3) : A2-A2 = J13-J41
- SE Impedance (solc,J8 /tolc,J3) : A6-A6 = J14-J42
- SE NEXT: (solc,J8) B3 = J16 - (solc,J8) V5 = J17
- SE FEXT: (solc,J8) B3 = J16 - (solc,J3) V5 = J44
- DIFF: Impedance (solc,J8 /tolc,J3) : A3b5 = J16-J17
- DIFF: NEXT: (solc,J8) A8b5 = J14-J17 - (solc,J8) V2V3 = J13-J16
- DIFF: FEXT: (solc,J8) A8b5 = J14-J17 - (tolc,J3) V4V3 = J41-J43

### SOLC CONNECTOR FOOTPRINT

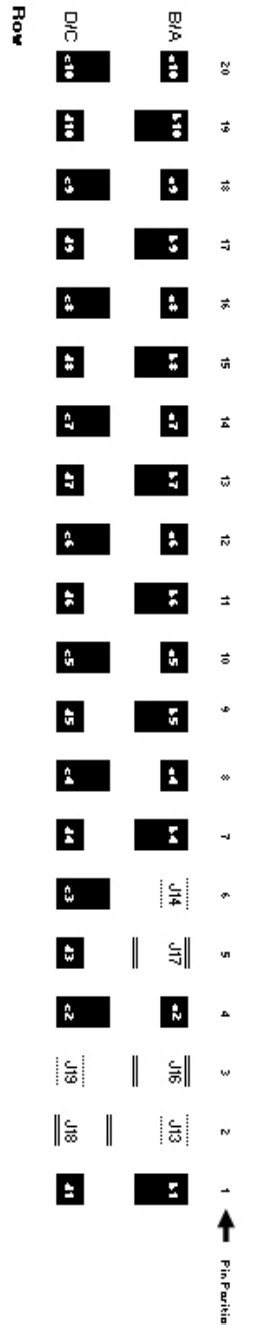

### TOLC CONNECTOR FOOTPRINT

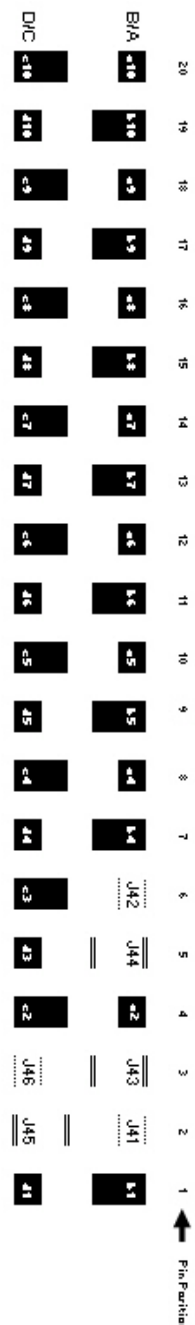

**Series:** TOLC/SOLC, 1.27mm (0.050") Contact Pitch, 0.64mm (0.025") Footprint Pitch  
**Description:**, Board-to-Board, Surface Mount, 6.35mm (0.250") Stack Height

## SOLC, J15 / TOLC, J4 Connector/Footprint Pinout Map (DP1)

Fixture Description: Mate single SOLC connector J15 to J4 on multiple TOLC connector PCB-100364-TST-02

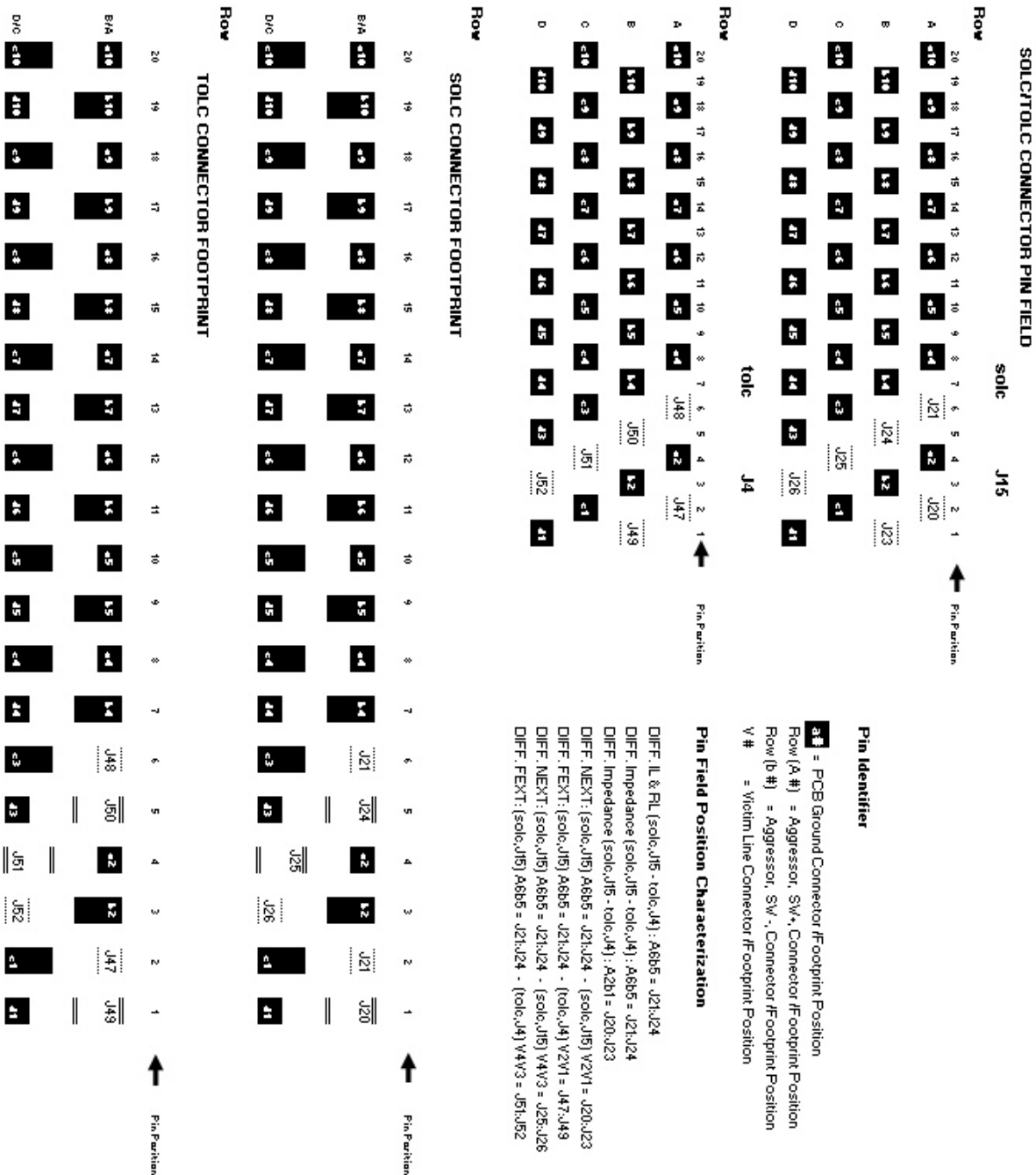

**Series:** TOLC/SOLC, 1.27mm (0.050") Contact Pitch, 0.64mm (0.025") Footprint Pitch  
**Description:**, Board-to-Board, Surface Mount, 6.35mm (0.250") Stack Height

## SOLC, J22 / TOLC, J5 Connector/Footprint Pinout Map (DP2)

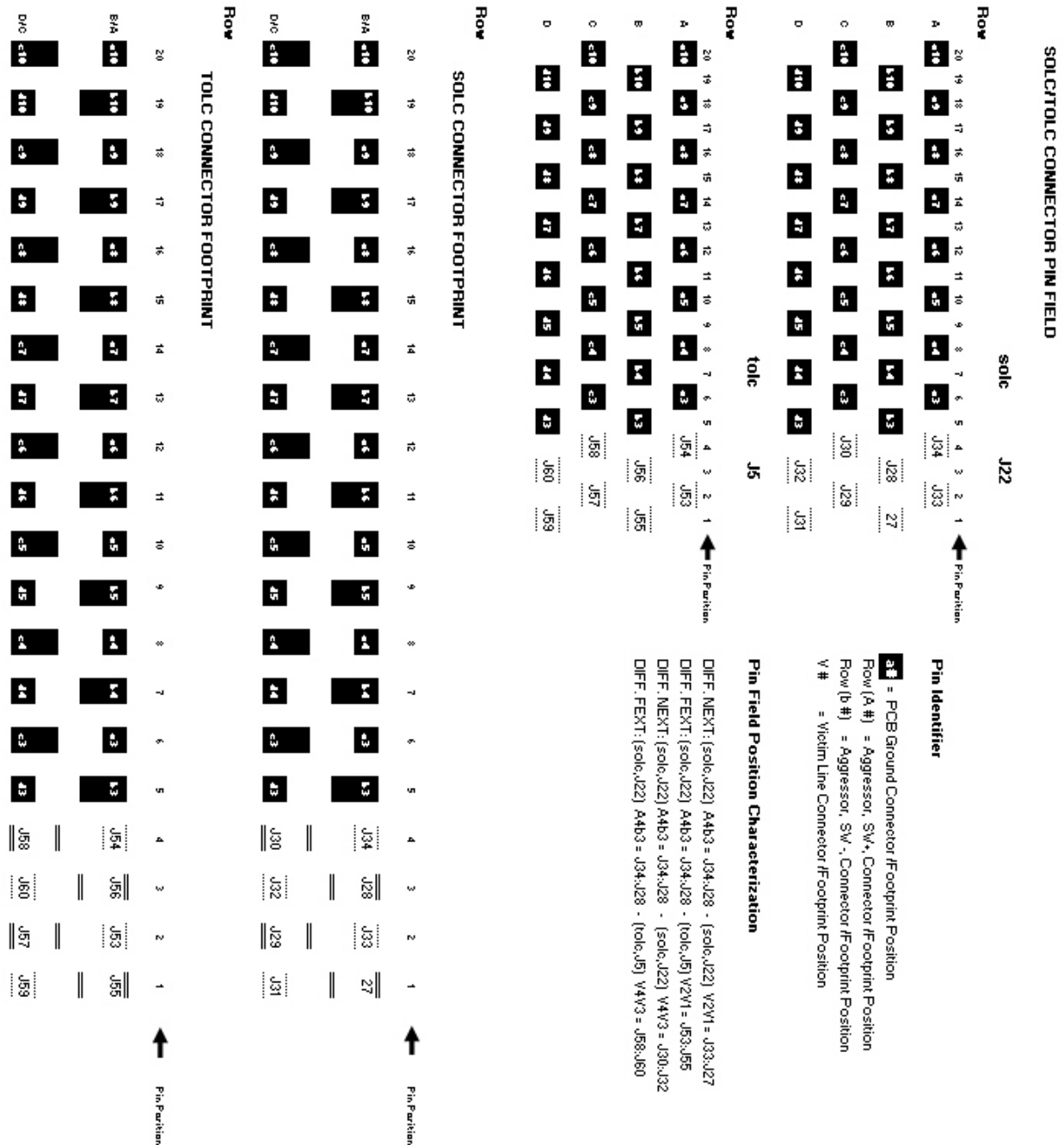

**Series:** TOLC/SOLC, 1.27mm (0.050") Contact Pitch, 0.64mm (0.025") Footprint Pitch  
**Description:**, Board-to-Board, Surface Mount, 6.35mm (0.250") Stack Height

## Appendix D – Test and Measurement Setup

Test instrument is the Tektronix CSA8000 Communication Signal Analyzer Mainframe. Four bays of the CSA8000 are occupied with three Tektronix 80E04 TDR/Sampling Heads and one Tektronix 80E03 Sampling Head. For this series of tests, four of the eight TDR/Sampling Head capability is used (*Figure 2*). Scattering parameters presented in this report are generated by TDA Systems IConnect. IConnect is a TDR based measurement software tool used in generating frequency domain related responses from high speed interconnects.

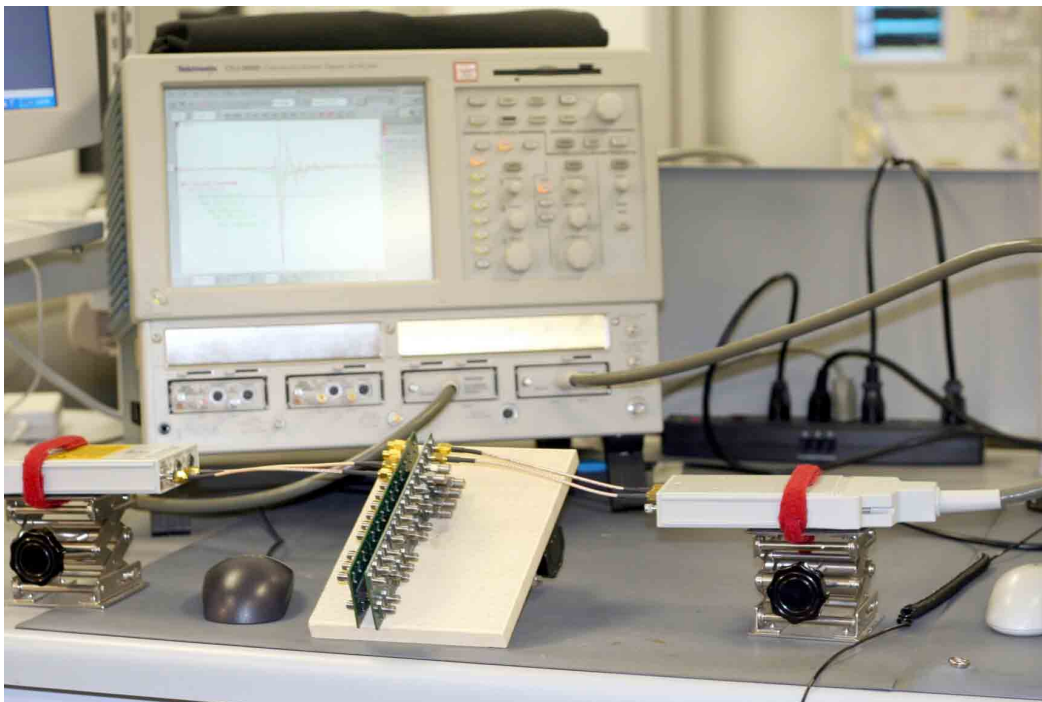

**Figure 2 Measurement Setup**

### Test Instruments & Accessories

<u>QTY</u>	<u>Description</u>
1	Tektronix CSA8000 Communication Signal Analyzer
3	Tektronix 80E04 Dual Channel 20 GHz TDR Sampling Module
4	6 inch RG316 Cable Assemblies (6 GHz)
10	Pasternack SMA 50 $\Omega$ Terminations (12 GHz)

**Series:** TOLC/SOLC, 1.27mm (0.050") Contact Pitch, 0.64mm (0.025") Footprint Pitch  
**Description:**, Board-to-Board, Surface Mount, 6.35mm (0.250") Stack Height

## Test Setup Configurations

The schematics below indicate the Single Ended signal configurations setup for each of the parameters characterized. To setup for differential signal parameters duplicate on the second line the same SE configuration for the parameter of interest.

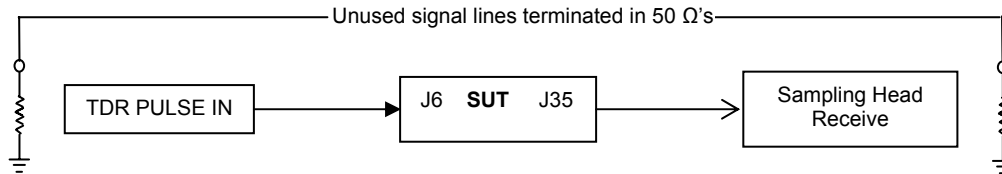

**Figure 3 - Insertion Loss, Impedance, Propagation Delay**

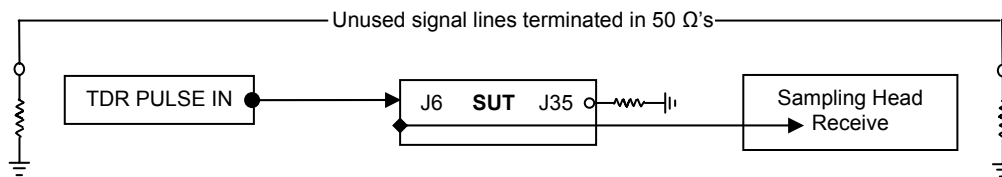

**Figure 4 - Return Loss, Impedance**

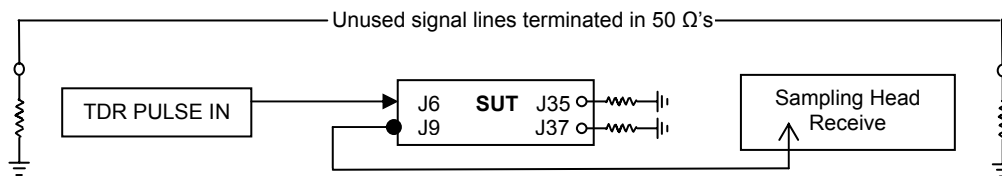

**Figure 5 - Near End Crosstalk**

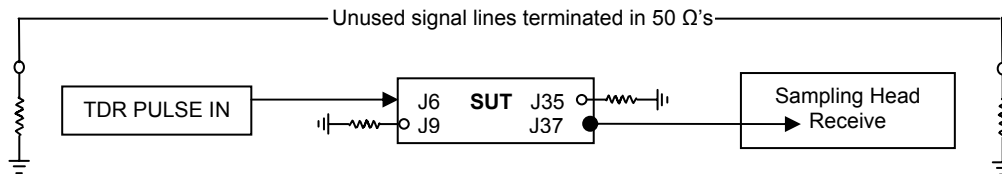

**Figure 6 - Far End Crosstalk**

**Series:** TOLC/SOLC, 1.27mm (0.050") Contact Pitch, 0.64mm (0.025") Footprint Pitch  
**Description:**, Board-to-Board, Surface Mount, 6.35mm (0.250") Stack Height

## Appendix E - Frequency and Time Domain Measurements

It is important to note before gathering measurement data that TDA Systems IConnect measurements and CSA8000 measurements are virtually the same measurements with diverse formats. This means that the operator, being extremely aware, can obtain SI time and frequency characteristics in an almost simultaneous fashion.

Since IConnect setup procedures are specific to the frequency information sought, it is mandatory that the sample preparation and CSA8000 functional setups be consistent throughout the waveform gathering process. If the operators test equipment permits recall sequencing between the various test parameter setups, it insures IConnect functional setups remain consistent with the TDR/TDT waveforms previously recorded. Related time and frequency test parameter data recorded for this report were gathered simultaneously.

### Frequency (S-Parameter) Domain Procedures

Frequency data extraction involves two steps that first measure the frequency related time domain waveform followed by post-processing of the time domain waveforms into loss and crosstalk response parameters versus frequency. The first step utilizes the Tektronix CSA8000 time based instrument to capture frequency related single-ended or differential signal types propagating through an appropriately prepared SUT. The second step involves a correlation of the time based waveforms using the TDA Systems IConnect software tool to post-process these waveforms into frequency response parameters. TDA Systems labels these frequency related waveform relationships as the *Step* and *DUT* reference. This report establishes the setup procedures for defining the *Step* and *DUT* reference for frequency parameters of interest. Once established, the *Step* and *DUT* references are post-processed in IConnect's S-parameter computations window.

### CSA8000 Setup

Listed below are the CSA 8000 functional menu setups used for single-ended and differential frequency response extractions. Both signal types utilize I-Connect software tools to generate S-parameter upper and lower frequency boundaries along with the step frequency. These frequency boundaries are determined by a time domain instruments functional settings such as window length, number of points and averaging capability. Once window length, number of points and averaging functions are set, maintain the same instrument settings throughout the extraction process.

**Series:** TOLC/SOLC, 1.27mm (0.050") Contact Pitch, 0.64mm (0.025") Footprint Pitch  
**Description:**, Board-to-Board, Surface Mount, 6.35mm (0.250") Stack Height

	<u>Single-Ended Signal</u>	<u>Differential Signal</u>
Vertical Scale:	100 mV/ Div:	100 mV/ Div:
Offset:	Default / Scroll	Default / Scroll
Horizontal Scale:	1nSec/ Div = 20 MHz step frequency	1nSec/ Div = 20 MHz step frequency
Max. Record Length:	4000 = Min. Resolution	4000 = Min. Resolution
Averages:	≥ 128	≥ 128

### Insertion Loss

*SUT Preparation (figure 3)* –The signal path for single ended transmission measurements was characterized using connector/pcb fixture SOLC, J1 / TOLC, J2 (ie. J6, J35). The differential transmission path measured is located on connector/pcb fixture SOLC, J15 / TOLC (ie. J21-J24, J48-J50). Terminate all unused transmission paths in the connector/pcb fixture bank using 50Ω high frequency (HF) terminations. Reference correct connector/footprint pinout map for insertion loss configuration detail.

*Step Reference* - Establish waveform by making a TDT transmission measurement that includes all cables, adapters, and/or probes connected in the test systems transmission path. Complete the transmission path by inserting a piggybacked SMA coaxial launch connector (*pictured on right*). Insert 2 piggybacked SMA launches for differential measurements.

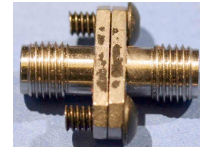

*DUT Reference* - Establish waveform by making an active TDT transmission measurement that includes all cables, adapters, and/or probes connected in the test systems transmission path. Insert the SUT between the test cables and record measurement.

### Return Loss

*SUT Preparation (figure 4)* – Measure the same signal paths used for the insertion loss characterizations. Terminate the excited paths at the far-end of the connector/pcb fixture. Terminate all unused transmission paths within the connector/pcb fixture bank in 50Ω's with HF terminations (*Reference Signal Launch and Monitoring Map*).

*Step Reference* - Establish waveform by making an active TDR reflection measurement that includes all cables, adapters, and/or probes connected in the test systems electrical path up to and including the open standard. Use un-terminated SMA (J) coaxial launches for single end and differential open standards. (**Note:** (see picture at right).

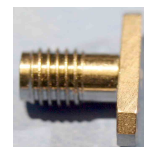

**Series:** TOLC/SOLC, 1.27mm (0.050") Contact Pitch, 0.64mm (0.025") Footprint Pitch  
**Description:**, Board-to-Board, Surface Mount, 6.35mm (0.250") Stack Height

*DUT Reference* - Establish waveform by making a TDR (matched) reflection measurement that includes all cables, adapters, and/or probes connected in the test systems signal path. A portion of the energy passing through the DUT is absorbed by the HF terminations and portion of the signal is reflected. The portions absorbed form a flat 50Ω single-ended or 100Ω differential impedance waveform response following the reflected response through the DUT.

#### Near-End Crosstalk (NEXT)

*SUT Preparation (figure 5)* – Four single-ended near end crosstalk configurations were monitored using connector/pcb fixtures SOLC, J1 / TOLC, J2 and SOLC, J8 /TOLC, J3. Five differential near-end crosstalk configurations were monitored using all four fixture convections. They were SOLC, J1/TOLC, J2, SOLC, J8 /TOLC, J3, SOLC, J15 /TOLC, J4 and SOLC, J22 / TOLC, J5. Terminate far end aggressor and victim lines using 50 Ω high frequency (HF) terminations. Also terminate all the unused transmission paths within the connector/pcb fixture bank. Reference connector/footprint pinout map for crosstalk configuration detail.

*Step Reference* - Establish waveform by making a TDR open measurement that includes all cables, adapters, and/or probes connected in the test systems electrical path up to and including an open standard. (**Note:** *The same step reference waveform generated for return loss is used in conjunction with the FEXT waveforms to post-process crosstalk s-parameters in IConnect . If testing equipment or the DUT is subject to a constant change in environmental conditions, it is recommended a new step reference be generated. Use the Return Loss Step Reference procedure.*

*DUT Reference* - Establish waveform by driving an aggressor signal line (i.e.; J6) and recording the TDR coupled energy at the adjacent near-end victim line (i.e.; J9). Repeat measurement procedures to establish the waveforms for the remaining single-ended and differential configurations. Reference correct connector/ footprint pinout map for crosstalk configuration detail.

#### Far-End Crosstalk (FEXT)

*SUT Preparation (figure 6)* - Four single-ended far end crosstalk configurations were monitored using connector/pcb fixtures SOLC, J1 / TOLC, J2 and SOLC, J8 /TOLC, J3. Five differential far end crosstalk configurations were monitored using all four fixture convections. They were SOLC, J1/TOLC, J2, SOLC, J8 /TOLC, J3, SOLC, J15 /TOLC, J4 and SOLC, J22 / TOLC, J5. Reference connector footprint pinout maps for crosstalk configuration details. Terminate the near end victim line and the aggressor line on the

**Series:** TOLC/SOLC, 1.27mm (0.050") Contact Pitch, 0.64mm (0.025") Footprint Pitch  
**Description:**, Board-to-Board, Surface Mount, 6.35mm (0.250") Stack Height

far end using 50  $\Omega$  high frequency (HF) terminations. Also terminate all unused transmission paths within the connector/pcb fixture bank.

*Step Reference* - Establish waveform by making a TDT transmission measurement that includes all cables, adapters, and probes connected in the test systems transmission path. Complete the transmission path by inserting a piggybacked SMA coaxial launch connector. Insert 2 SMA launches for differential measurements. **(Note: The same step reference waveform generated for insertion loss is used in conjunction with the FEXT waveforms to post-process crosstalk s-parameters in IConnect . If testing equipment or the DUT is subject to a constant change in environmental conditions, it is recommended a new step reference be generated. Use the Insertion Loss Step Reference procedure.**

*DUT Reference* - Establish waveform by driving an aggressor signal line (i.e.; J6) and recording the TDR coupled energy at the adjacent far-end victim line (i.e.; J37). Repeat measurement procedures to establish the waveforms for the remaining single-ended and differential configurations. Reference correct connector/footprint pinout map for crosstalk configuration detail

**Series:** TOLC/SOLC, 1.27mm (0.050") Contact Pitch, 0.64mm (0.025") Footprint Pitch  
**Description:**, Board-to-Board, Surface Mount, 6.35mm (0.250") Stack Height

## **Time Domain Procedures**

Measurements involving digital type pulses are performed utilizing either Time Domain Reflectometer (TDR) or Time Domain Transmission (TDT) methods. For this series of tests, TDR methods are employed for the impedance and propagation delay measurements. Crosstalk measurements utilize TDT methods. The Tektronix 80E04 TDR/ Sampling Head provide both the signaling type and sampling capability necessary to accurately and fully characterize the SUT.

### Impedance

The signal line(s) of the SUT's signal configuration is energized with a TDR pulse. The far-end of the energized signal line is terminated in the test systems characteristic impedance (e.g.; 50Ω terminations). Terminating the adjacent signal lines in the test systems characteristic impedance limits unwanted changes to the impedance response. (Figure 3).

### Propagation Delay

This connector series uses the fastest edge rate (30ps) of the TDR impedance waveform to measure propagation delay. . Differential or single ended signal delay is the measured difference of propagation between the known signal trace delay and the delay of a mated SUT. The measurement is a one-way propagation result. Termination of the adjacent signal lines into the test systems characteristic impedance eliminate alternate current paths providing for better measurement accuracy (Figure 3). Reference PCB100364-TST-02 boards for PD reference trace delay lines).

### Crosstalk

An active pulsed waveform is transmitted through a selected SUT signal line. The adjacent quiet signal lines are monitored for the coupled energy at the near-end and far-end. Active and quiet lines not being monitored are terminated in the test systems characteristic impedance. Signal lines adjacent to the quiet lines remain terminated on both ends throughout the test sequence. Failing to terminate the active near or far end, quiet lines, or in some cases, signal lines adjacent to the quiet line may have an effect on amplitude and shape of the coupled energy (Figures 5 & 6).

**Series:** TOLC/SOLC, 1.27mm (0.050") Contact Pitch, 0.64mm (0.025") Footprint Pitch

**Description:**, Board-to-Board, Surface Mount, 6.35mm (0..250") Stack Height

## **Appendix F – Glossary of Terms**

**BC** – Best Case crosstalk configuration

**DP** – Differential Pair signal configuration

**DUT** – Device under test; TDA IConnect reference waveform

**FEXT** – Far-End Crosstalk

**GSG** – Ground–Signal–Ground; geometric configuration

**NEXT** – Near-End Crosstalk

**PCB** – Printed Circuit Board

**SE** – Single-Ended

**SI** – Signal Integrity

**SUT** – System under test

**TDR** – Time Domain Reflectometry

**TDT** – Time Domain Transmission

**WC** – Worse Case crosstalk configuration

**Xrow<sup>se</sup>** – Cross ground/ power bar crosstalk, single-ended signal

**Xrow<sup>diff</sup>** – Cross ground/ power bar crosstalk, differential signal

**Z** – Impedance (expressed in ohms)

**Static (S)** = adjacent contact position does not exist, generally the end positions of the connector pin field