

DECEMBER 27, 2001

TEST REPORT #201611

MECHANICAL SHOCK/RANDOM VIBRATION
GAS TIGHT
CURRENT CYCLING

PEC-03-02-T-S

SAMTEC, INC.

(TC0141-0542)

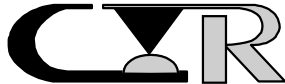


APPROVED BY: THOMAS PEEL
VICE PRESIDENT AND
DIRECTOR OF TEST PROGRAM DEVELOPMENT
CONTECH RESEARCH, INC.



REVISION HISTORY

DATE	REV. NO.	DESCRIPTION	ENG.
12/27/2001	1.0	Initial Issue	TP

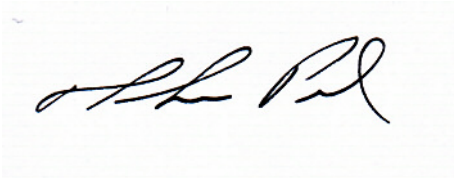


CERTIFICATION

This is to certify that the evaluation described herein was designed and executed by personnel of Contech Research, Inc. It was performed with the concurrence of Samtec, Inc., of New Albany, IN who was the test sponsor.

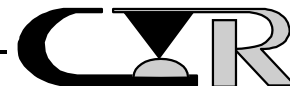
All equipment and measuring instruments used during testing were calibrated and traceable to NIST according to ISO 10012-1 and ANSI/NCSL Z540-1, as applicable.

All data, raw and summarized, analysis and conclusions presented herein are the property of the test sponsor. No copy of this report, except in full, shall be forwarded to any agency, customer, etc., without the written approval of the test sponsor and Contech Research.



Thomas Peel
Vice President And
Director Of Test Program Development
Contech Research, Inc.

TP:js



SCOPE

To perform testing on the PEC series connector as manufactured and submitted by the test sponsor Samtec, Inc.

APPLICABLE DOCUMENTS

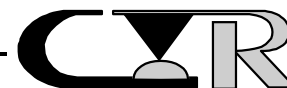
1. Unless otherwise specified, the following documents of issue in effect at the time of testing performed form a part of this report to the extent as specified herein. The requirements of sub-tier specifications and/or standards apply only when specifically referenced in this report.
2. Product Specifications: TC0141-0542 Flow Chart
3. Standards: EIA Publication 364

TEST SAMPLES AND PREPARATION

1. The following test samples were submitted by the test sponsor, Samtec, Inc., for the evaluation to be performed by Contech Research, Inc.

<u>Description</u>	<u>Part Number</u>
PEC Series	PEC-03-02-T-S

2. Test samples were supplied assembled and terminated to test boards by the test sponsor.
3. Test boards for mounting test samples were supplied by the test sponsor.
4. Applicable qualified mating boards (low level circuit resistance and current cycling) were supplied by the test sponsor.
5. Figure #1 illustrates the test board layout used for mounting test samples.
6. The test samples were tested in their 'as received' condition.
7. Unless otherwise specified in the test procedures used, no further preparation was used.



TEST SELECTION

1. See Test Plan Flow Diagram, Figure #2, for test sequences used.
2. Test set ups and/or procedures which are standard or common are not detailed or documented herein provided they are certified as being performed in accordance with the applicable (industry or military) test methods, standards and/or drawings as specified in the detail specification.

SAMPLE CODING

1. All samples were coded. Mated test samples remained with each other throughout the test group/sequences for which they were designated. Coding was performed in a manner which remained legible for the test duration.
2. The test samples were coded in the following manner:

Test Board ID#'s

Group 1 : G1-1,G1-2,G1-3,G1-4,G1-5

Group 2 : G2-1,G2-2,G2-3,G2-4,G2-5

Group 3 : G3-1,G3-2,G3-3,G3-4,G3-5

Position ID#'s: 1 - 1, 2 or 3

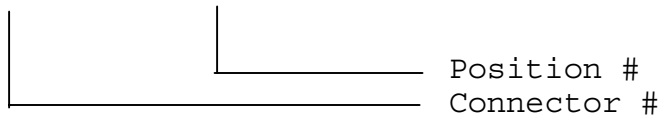


FIGURE #1

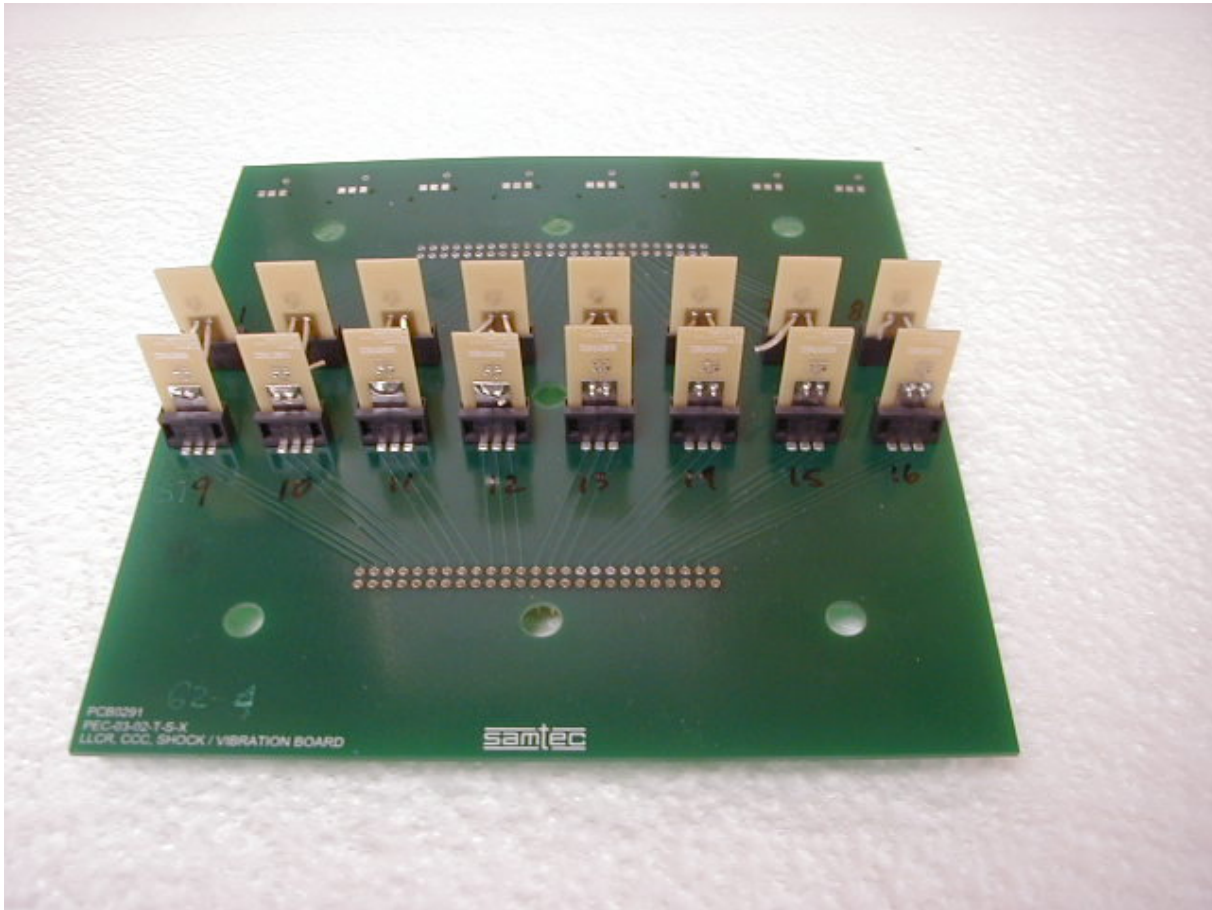
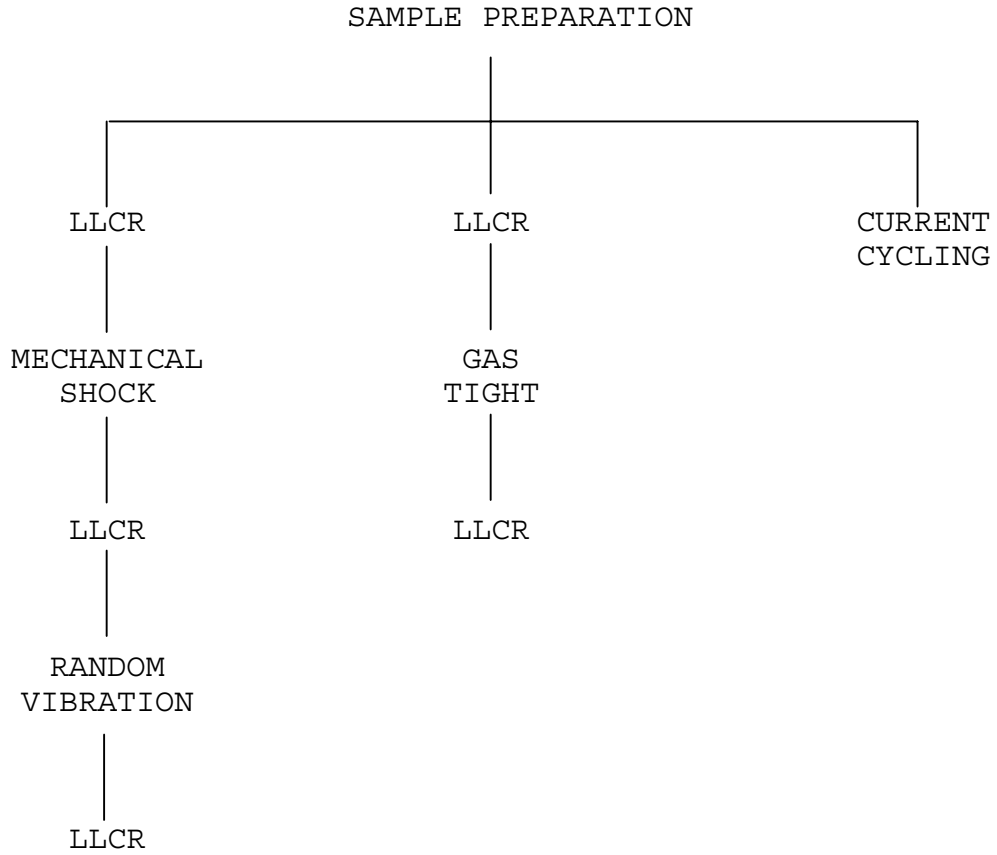


FIGURE #2

TEST PLAN FLOW DIAGRAM



GROUP 1

GROUP 2

GROUP 3



DATA SUMMARY

<u>TEST</u>	<u>REQUIREMENT</u>	<u>RESULTS</u>
<u>GROUP 1</u>		
LLCR MECHANICAL SHOCK	RECORD NO DAMAGE	2.8 mΩ MAX. PASSED
LLCR RANDOM VIBRATION	+10.0 mΩ MAX. CHG. NO DAMAGE	+0.9 mΩ MAX. CHG. PASSED
LLCR	+10.0 mΩ MAX. CHG.	+0.8 mΩ MAX. CHG.
<u>GROUP 2</u>		
LLCR GAS TIGHT	RECORD NO DAMAGE	2.9 mΩ MAX. PASSED
LLCR	+10.0 mΩ MAX. CHG.	+0.5 mΩ MAX. CHG.
<u>GROUP 3</u>		
CURRENT CYCLING VOLTAGE DROP	NO DAMAGE	PASSED
@ 250 HOURS	RECORD	25.8 mV MAX.
@ 500 HOURS	RECORD	24.1 mV MAX.
TEMPERATURE RISE		
@ 250 HOURS	RECORD	+12.4°C ABOVE AMB.
@ 500 HOURS	RECORD	+11.0°C ABOVE AMB.



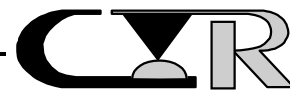
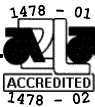
EQUIPMENT LIST

ID#	Next Cal	Last Cal	Equipment Name	Manufacturer	Model #	Serial #	Accuracy	Freq. Cal
14	5/30/02	5/30/01	Accelerometer	PCB Piezotronics	302A	7040	See Cal Cert	12mon
20			Bench Oven	Hot Pack	1303	30364	N/A	Each Test
34			Shock Machine	Avco	SM110-3	1047	See ID# 14 & 117	Each Test
117	6/12/02	6/12/01	Digitizing Scope	Hewlett Packard	54200	2445A 00127	See Cal Cert	12mon.
164	10/16/02	10/16/01	Digital Multimeter	Fluke Mfg.	75	43120894	See Cal Cert	12mon
235			DC Power Supply 100 Amps	Hewlett Packard	6260B	2326A03906	N/A	Each Test
281			Vibration Power Amp	Ling Dynamics	DPA 10K	156	N/A	N/A
282			Vibration Shaker Table	Ling Dynamics	V-730	163	N/A	N/A
410	6/20/02	6/20/01	Current Shunt	Empro Co.	200A-50	05	±1%	12mon
413			Computer	Myriad	386SX	911897	N/A	N/A
440			Scanner Main Frame	Keithley Co.	706	540957	See Manual	Each Test
553	11/28/02	11/28/01	12 channel Power Unit	PCB Co.	483A	1303	See Cal Cert	12mon
580	11/1/02	11/1/01	Digital Multimeter	Hewlett Packard Co.	3478A	2545A22620	See Cal.Cert.	12mon
584	8/15/02	8/15/01	Digital Multimeter	Hewlett Packard Co.	3478A	2911AS4039	See Cal.Cert.	12 mon.
684	6/11/02	6/11/01	Accelerometer	PCB. Co.	353B04	47648	See Cal Cert.	12mon
874			Computer	M&P	Vectra		N/A	N/A
1047	10/23/02	10/23/01	Microohm Meter	Keithley	580	0705731	See Cal Cert	12mon
1136	5/30/02	5/30/01	Signal Condt.	PCB	480EO9	23397	See Cal. Cert.	12mon
1279			Computer	ARC Co.	Pent-450	030175	N/A	N/A
1301	8/13/02	8/13/01	Sine/Rndm Vib Control	Hewlett Packard	35650B	3151A00164	See Manual	12mon



TEST RESULTS

GROUP 1



PROCEDURE: Continued

2. Test Conditions:

- a) Test Current : 10 milliamps
- b) Open Circuit Voltage : 20 millivolts
- c) No. of Positions Tested : 3 positions per connector,
16 connectors per board

3. The points of application are shown in Figure #3.

REQUIREMENTS:

Low level circuit resistance shall be measured and recorded.

RESULTS:

1. The following is a summary of the data observed:

LOW LEVEL CIRCUIT RESISTANCE
(Milliohms)

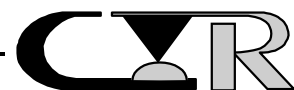
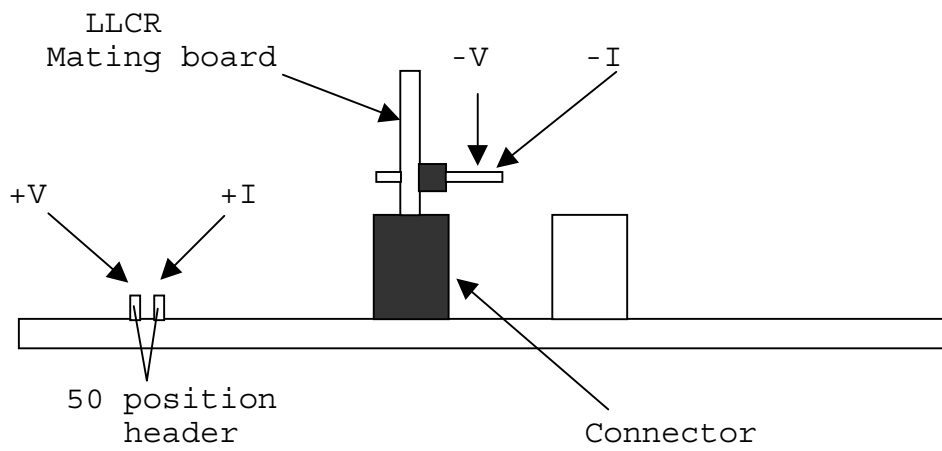
<u>Board ID#</u>	<u>Avg.</u>	<u>Max.</u>	<u>Min.</u>
G1-1	2.3	2.5	2.2
G1-2	2.5	2.8	2.3
G1-3	2.2	2.4	2.1
G1-4	2.5	2.7	2.3
G1-5	2.4	2.8	2.3

2. See data files 20161101 through 20161105 for individual data points.



FIGURE #3

TYPICAL LLCR SET-UP



PROJECT NO.: 201611 SPECIFICATION: N/A

PART NO.: PEC-03-02-T-S PART DESCRIPTION: Edge Card
Connector

SAMPLE SIZE: ID#G1-1,G1-2,G1-3, TECHNICIAN: RO
G1-4,G1-5

START DATE: 12/10/01 COMPLETE DATE: 12/10/01

ROOM AMBIENT: 23°C RELATIVE HUMIDITY: 25%

EQUIPMENT ID#: 14, 34, 117, 413, 1047, 1136

MECHANICAL SHOCK (SPECIFIED PULSE)

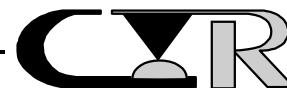
PURPOSE:

To determine the mechanical and electrical integrity of connectors for use with electronic equipment subjected to shocks such as those expected from handling, transportation, etc.

PROCEDURE:

1. The test was performed in accordance with TC0141-0542Flowchart and EIA 364, Test Procedure 27.
2. Test Conditions:
 - a) Peak Value : 100 G
 - b) Duration : 6 Milliseconds
 - c) Wave Form : Sawtooth
 - d) Velocity : 9.7 feet Per Second
 - e) No. of Shocks : 3 Shocks/Direction, 3 Axis (18 Total)
3. The test fixture was so designed as not to apply any force or stress directly to the test samples nor to prevent axial movement of the mating device.
4. All subsequent variable testing was performed in accordance with the procedures previously indicated.
5. Figure #4 illustrates the test sample fixturing utilized during the test.

REQUIREMENTS: See next page.



REQUIREMENTS:

1. There shall be no evidence of axial movement of the test samples relative to each other.
2. There shall be no evidence of physical damage to the test samples as tested.
3. The change in low level circuit resistance shall not exceed +10.0 milliohms.

RESULTS:

1. There was no evidence of axial movement of the mating card relative to the connectors.
2. There was no evidence of physical damage to the test samples as tested.
3. The following is a summary of the data observed:

CHANGE IN
LOW LEVEL CIRCUIT RESISTANCE
(Milliohms)

<u>Board ID#</u>	<u>Avg. Change</u>	<u>Max. Change</u>
G1-1	+0.1	+0.9
G1-2	+0.1	+0.3
G1-3	+0.0	+0.1
G1-4*	+0.0	+0.1
G1-5	+0.0	+0.5

* Damage occurred to connector ID#8 while changing axis during Mechanical Shock. LLCR was not performed as a result of the damage.

4. See data files 20161101 through 20161105 for individual data points.
5. The Mechanical Shock characteristics are shown in Figures #5 (Calibration Pulse) and #6 (Test Pulse). Each figure displays the shock pulse contained within the upper and lower limits as defined by the appropriate test specification.

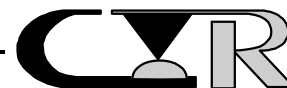


FIGURE #4

MECHANICAL SHOCK FIXTURING

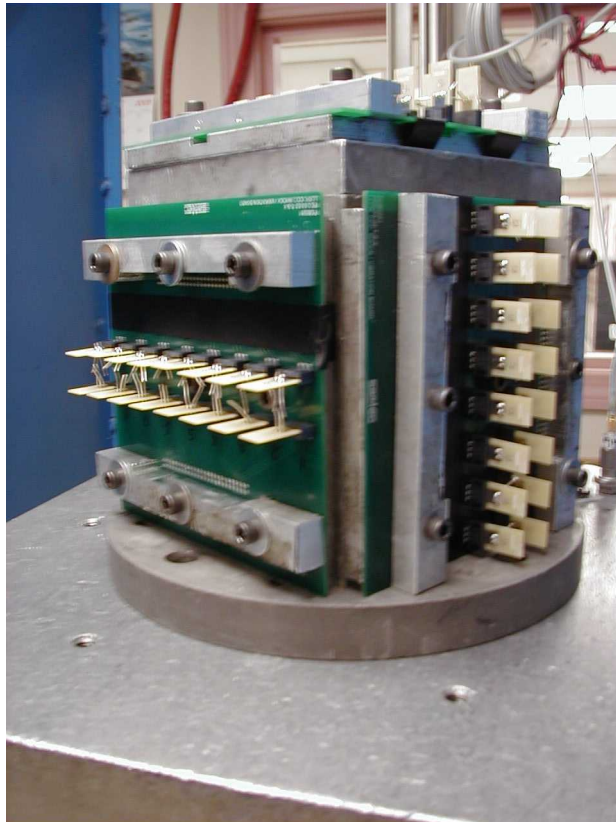
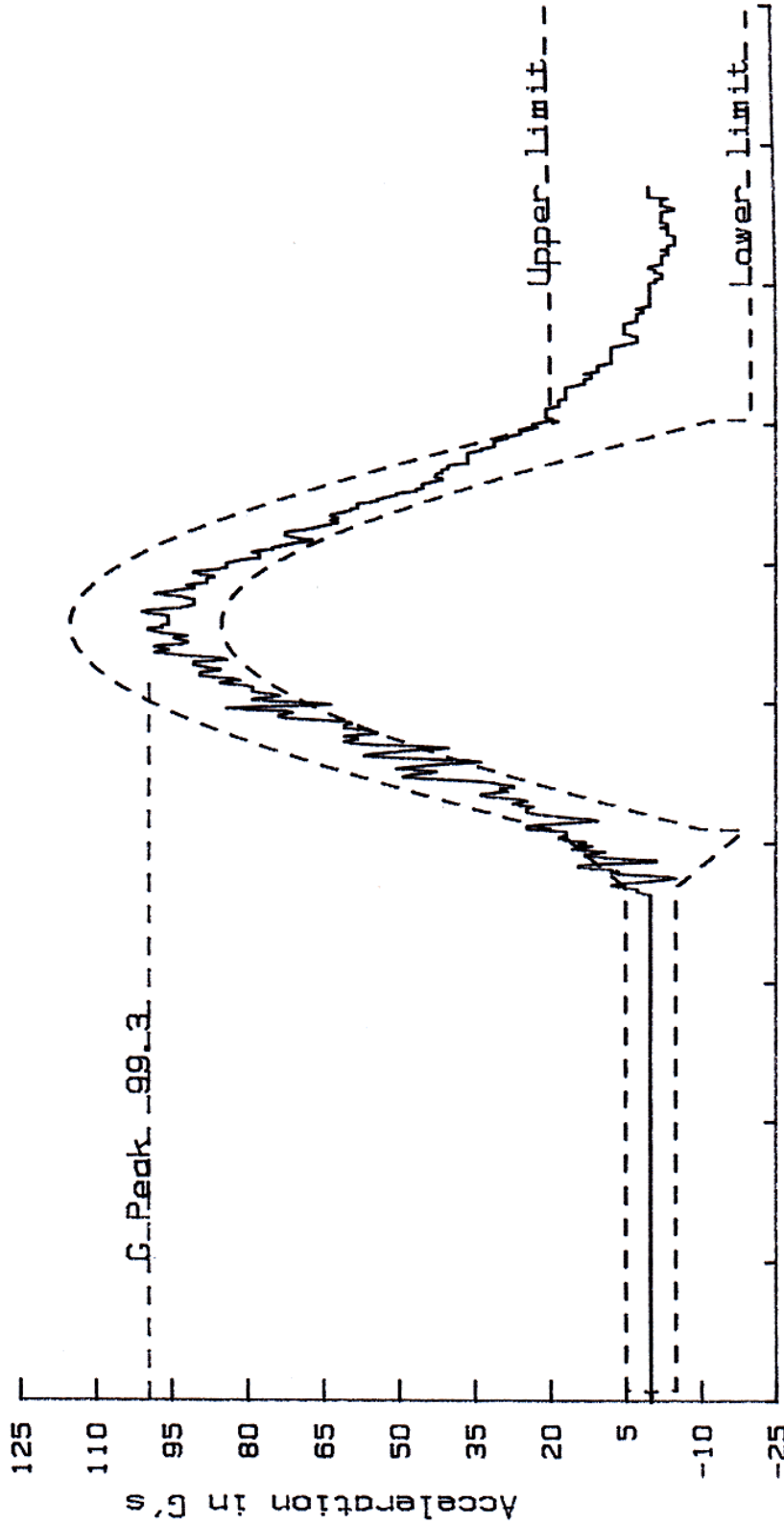


FIGURE #5

Samtec
Seq 1
EIA-Std 364 TC C



Duration 2 milliseconds/div
 Project #: 201611 CAL.
 File #: 02
 Tech: R.O.
 Date: 10-DEC-01
 Contech Research Inc

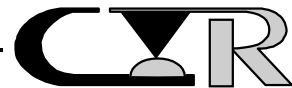
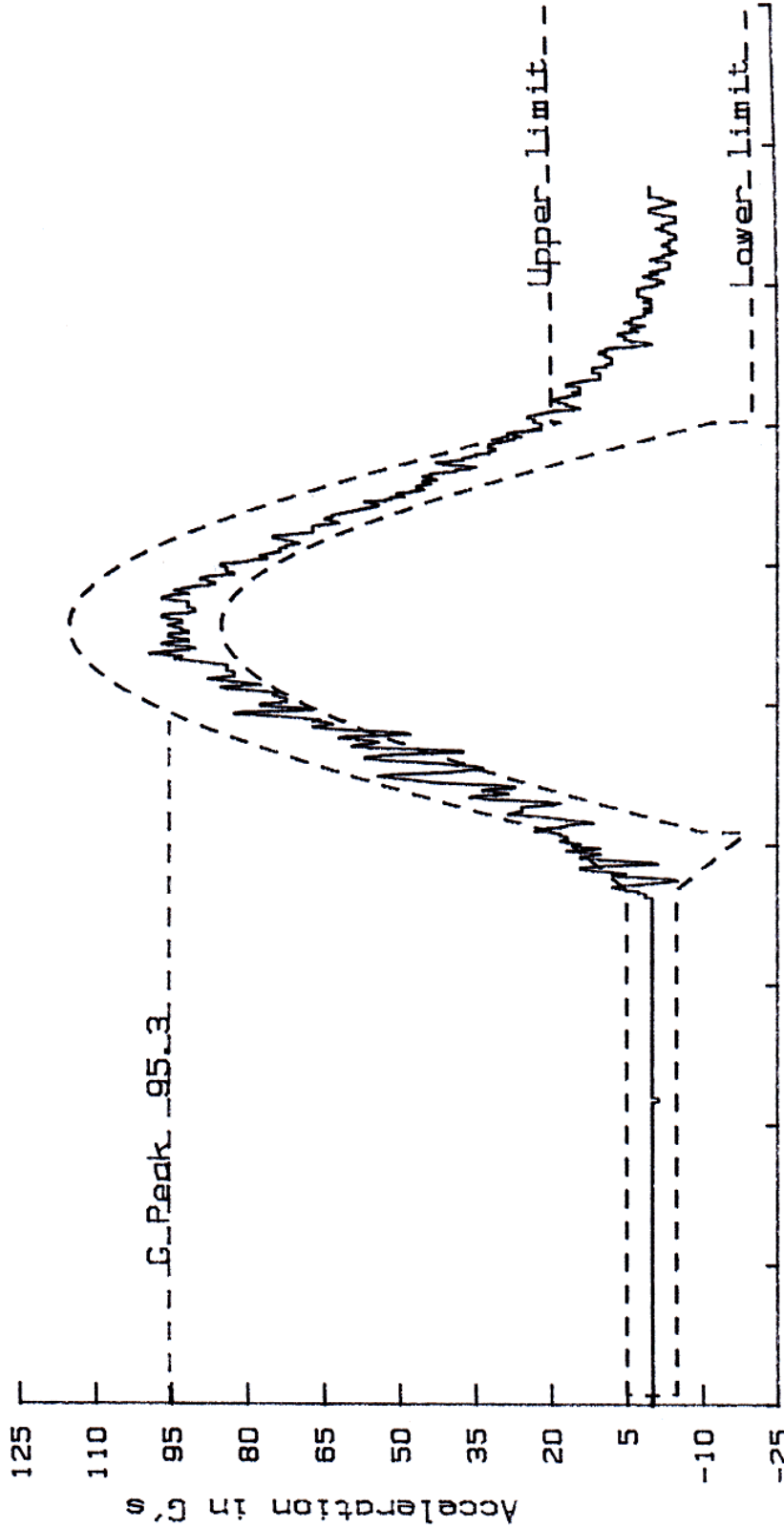


FIGURE #6

Samtec
Seq 1
EIA-Std 364 TC C



Duration 2 milliseconds/div

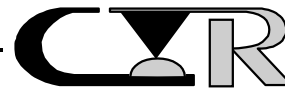
Project #: 201611 ACT.

File #: 03

Contech Research Inc

Tech: R.O.

Date: 10-DEC-01



PROJECT NO.: 201611 SPECIFICATION: N/A

PART NO.: PEC-03-02-T-S PART DESCRIPTION: Edge Card Connector

SAMPLE SIZE: ID#G1-1,G1-2,G1-3, TECHNICIAN: RO
G1-4,G1-5

START DATE: 12/11/01 COMPLETE DATE: 12/13/01

ROOM AMBIENT: 23°C RELATIVE HUMIDITY: 28%

EQUIPMENT ID#: 281, 282, 413, 553, 684, 874, 1047, 1301

VIBRATION, RANDOM

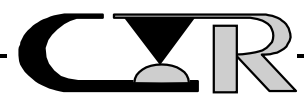
PURPOSE:

1. To determine if the contact system is susceptible to fretting corrosion.
2. To determine if the electrical stability of the system has degraded when exposed to a vibratory environment.

PROCEDURE:

1. The test was performed in accordance with Samtec's TC)141-0542flowchart EIA 364, Test Procedure 28.
2. Test Conditions:
 - a) Power Spectral Density : 0.04
 - b) G 'RMS' : 7.56
 - c) Frequency : 50 to 2000 Hertz
 - d) Duration : 2 hours/axis, 3 axis total
3. The test fixture was so designed as not to apply any force or stress directly to the test samples nor to prevent axial movement of the mating device.
4. Figure #7 illustrates the test sample fixturing utilized during the test.
5. All subsequent variable testing was performed in accordance with procedures previously indicated.

REQUIREMENTS: See next page.



REQUIREMENTS:

1. There shall be no evidence of physical damage to the test samples as tested.
2. There shall be no evidence of axial movement of the test samples relative to each other.
3. The change in low level circuit shall not exceed +10.0 milliohms.

RESULTS:

1. There was no evidence of physical damage to the test samples as tested.
2. There was no evidence of axial movement of the mating boards relative to the connectors.
3. The following is a summary of the observed data:

CHANGE IN
LOW LEVEL CIRCUIT RESISTANCE
(Milliohms)

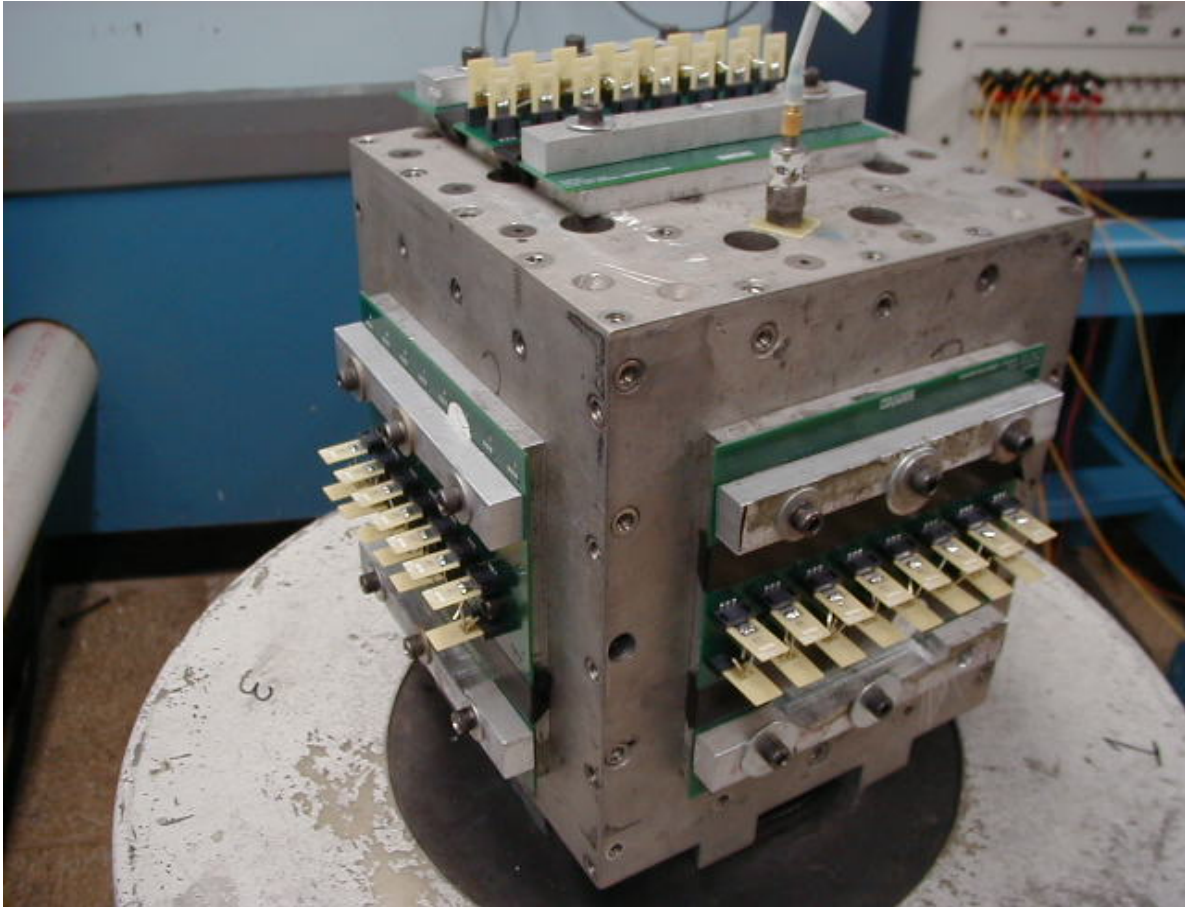
<u>Board ID#</u>	<u>Avg. Change</u>	<u>Max. Change</u>
G1-1	+0.1	+0.3
G1-2	+0.1	+0.3
G1-3	+0.0	+0.2
G1-4	+0.1	+0.4
G1-5	+0.1	+0.8

4. See data files 20161101 through 20161105 for individual data points.

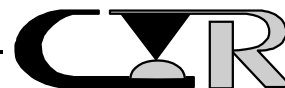


FIGURE #7

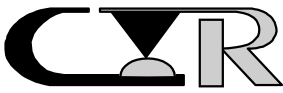
RANDOM VIBRATION FIXTURING



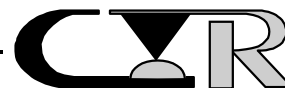
Low Level Contact Resistance					
Project:	201611			Spec:	EIA 364, Tp 23
Customer:	Samtec			Subgroup:	Seq 1 (Brd # G1-1)
Product:	Series PEC connector			File #:	20161101
Description:	PN: PEC-03-02-T-S				
Open circuit voltage:	20mv			Current:	10 ma
Delta values units: milliohms					
Temp °C	22	23	23		
R.H. %	30	25	28		
Date:	03Dec01	10Dec01	13Dec01		
Pos. ID	Initial	M. Shock	Vibration		
1-1	2.5	0.9	0.1		
1-2	2.4	0.3	0.1		
1-3	2.5	0.3	0.1		
2-1	2.4	0.0	0.0		
2-2	2.3	0.0	0.0		
2-3	2.4	0.0	0.0		
3-1	2.4	0.1	0.1		
3-2	2.3	0.1	0.1		
3-3	2.4	0.0	0.0		
4-1	2.3	0.1	0.1		
4-2	2.3	0.0	0.0		
4-3	2.3	0.0	0.0		
5-1	2.4	0.0	0.0		
5-2	2.3	0.0	0.1		
5-3	2.4	0.0	0.1		
6-1	2.3	0.0	0.1		
6-2	2.2	0.1	0.2		
6-3	2.3	0.1	0.3		
7-1	2.4	0.0	0.0		
7-2	2.4	0.0	0.0		
7-3	2.4	0.0	0.0		
8-1	2.3	0.0	0.1		
8-2	2.2	0.0	0.1		
8-3	2.3	0.0	0.2		
9-1	2.4	0.1	0.1		
9-2	2.4	0.0	0.0		
9-3	2.4	0.1	0.1		
10-1	2.3	0.1	0.1		
10-2	2.3	0.0	0.1		
10-3	2.3	0.2	0.1		
11-1	2.3	0.1	0.1		
11-2	2.2	0.1	0.1		
11-3	2.3	0.1	0.1		
12-1	2.3	0.2	0.2		
12-2	2.2	0.0	0.0		



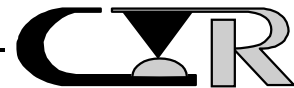
	Temp °C	22	23	23			
	R.H. %	30	25	28			
	Date:	03Dec01	10Dec01	13Dec01			
	Pos. ID	Initial	M. Shock	Vibration			
	12-3	2.3	0.0	0.1			
	13-1	2.4	0.1	0.2			
	13-2	2.2	0.1	0.2			
	13-3	2.4	0.1	0.1			
	14-1	2.4	0.0	0.0			
	14-2	2.2	0.0	0.0			
	14-3	2.3	0.0	0.0			
	15-1	2.3	0.0	0.1			
	15-2	2.2	0.0	0.1			
	15-3	2.3	0.1	0.0			
	16-1	2.4	0.1	0.1			
	16-2	2.3	0.0	0.0			
	16-3	2.4	0.1	0.1			
	MAX	2.5	0.9	0.3			
	MIN	2.2	0.0	0.0			
	AVG	2.3	0.1	0.1			
	STD	0.1	0.1	0.1			
	Open	0	0	0			
	Tech	RO	RO	RO			
	Equip ID	413	413	413			
		1047	1047	1047			



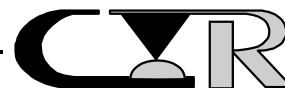
Low Level Contact Resistance					
Project:	201611			Spec:	EIA 364, Tp 23
Customer:	Samtec			Subgroup:	Seq 1 (Brd # G1-2)
Product:	Series PEC connector			File #:	20161102
Description:	PN: PEC-03-02-T-S				
Open circuit voltage:	20mv			Current:	10 ma
Delta values units: milliohms					
Temp °C	23	23	23		
R.H. %	30	25	28		
Date:	04Dec01	10Dec01	13Dec01		
Pos. ID	Initial	M. Shock	Vibration		
1-1	2.8	0.1	0.1		
1-2	2.6	0.2	0.2		
1-3	2.7	0.1	0.1		
2-1	2.5	0.1	0.1		
2-2	2.4	0.1	0.0		
2-3	2.5	0.1	0.0		
3-1	2.7	0.0	0.0		
3-2	2.6	-0.1	-0.1		
3-3	2.7	0.0	0.1		
4-1	2.4	0.0	0.0		
4-2	2.4	0.1	0.0		
4-3	2.5	0.0	-0.1		
5-1	2.6	0.1	0.1		
5-2	2.5	0.2	0.0		
5-3	2.6	0.0	0.3		
6-1	2.3	0.0	0.0		
6-2	2.3	0.0	0.0		
6-3	2.3	0.0	0.0		
7-1	2.5	0.2	0.3		
7-2	2.3	0.0	0.0		
7-3	2.4	0.1	0.1		
8-1	2.4	0.1	0.2		
8-2	2.3	0.0	0.1		
8-3	2.4	0.0	0.1		
9-1	2.6	0.1	0.2		
9-2	2.5	0.1	0.3		
9-3	2.6	0.0	-0.1		
10-1	2.5	0.0	0.1		
10-2	2.5	0.0	0.0		
10-3	2.5	0.0	0.0		
11-1	2.5	0.0	0.0		
11-2	2.4	0.0	0.0		
11-3	2.5	0.1	0.1		
12-1	2.7	0.1	0.1		
12-2	2.6	0.1	0.1		



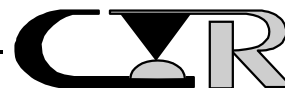
	Temp °C	23	23	23			
	R.H. %	30	25	28			
	Date:	04Dec01	10Dec01	13Dec01			
	Pos. ID	Initial	M. Shock	Vibration			
	12-3	2.7	0.1	0.1			
	13-1	2.5	0.0	0.1			
	13-2	2.4	0.1	0.1			
	13-3	2.5	0.0	0.2			
	14-1	2.5	0.1	0.1			
	14-2	2.3	0.3	0.1			
	14-3	2.4	0.0	0.1			
	15-1	2.4	0.0	0.1			
	15-2	2.4	0.0	0.1			
	15-3	2.5	0.0	0.0			
	16-1	2.6	0.0	0.1			
	16-2	2.4	0.1	0.0			
	16-3	2.6	0.1	0.1			
	MAX	2.8	0.3	0.3			
	MIN	2.3	-0.1	-0.1			
	AVG	2.5	0.1	0.1			
	STD	0.1	0.1	0.1			
	Open	0	0	0			
	Tech	RO	RO	RO			
	Equip ID	413	413	413			
		1047	1047	1047			



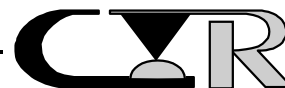
Low Level Contact Resistance					
Project:	201611			Spec:	EIA 364, Tp 23
Customer:	Samtec			Subgroup:	Seq 1 (Brd # G1-3)
Product:	Series PEC connector			File #:	20161103
Description:	PN: PEC-03-02-T-S				
Open circuit voltage:	20mv			Current:	10 ma
Delta values units: milliohms					
Temp °C	23	23	23		
R.H. %	30	25	28		
Date:	04Dec01	10Dec01	13Dec01		
Pos. ID	Initial	M. Shock	Vibration		
1-1	2.2	0.1	0.1		
1-2	2.2	0.0	0.1		
1-3	2.3	0.0	0.0		
2-1	2.3	0.0	0.1		
2-2	2.2	0.0	0.1		
2-3	2.2	0.0	0.1		
3-1	2.2	0.0	0.0		
3-2	2.2	0.0	0.0		
3-3	2.2	0.0	0.0		
4-1	2.3	0.0	0.0		
4-2	2.3	-0.1	0.0		
4-3	2.3	0.0	0.0		
5-1	2.2	0.0	0.0		
5-2	2.2	0.0	0.1		
5-3	2.2	0.1	0.1		
6-1	2.2	0.0	0.0		
6-2	2.1	0.0	0.0		
6-3	2.2	0.0	0.0		
7-1	2.2	0.1	0.1		
7-2	2.1	0.0	0.0		
7-3	2.2	0.0	0.0		
8-1	2.3	0.0	0.0		
8-2	2.1	0.0	0.0		
8-3	2.2	-0.1	0.1		
9-1	2.4	0.0	0.0		
9-2	2.3	0.0	0.0		
9-3	2.3	0.0	0.0		
10-1	2.3	0.1	0.1		
10-2	2.2	0.1	0.2		
10-3	2.2	0.0	0.1		
11-1	2.3	0.0	0.1		
11-2	2.2	0.0	0.0		
11-3	2.3	0.0	0.0		
12-1	2.3	0.0	0.0		
12-2	2.2	0.0	0.1		



	Temp °C	23	23	23			
	R.H. %	30	25	28			
	Date:	04Dec01	10Dec01	13Dec01			
	Pos. ID	Initial	M. Shock	Vibration			
	12-3	2.3	0.0	0.1			
	13-1	2.3	0.0	0.0			
	13-2	2.2	0.0	0.0			
	13-3	2.3	0.0	0.0			
	14-1	2.4	0.0	0.0			
	14-2	2.2	0.0	0.0			
	14-3	2.3	0.0	0.0			
	15-1	2.3	0.0	0.0			
	15-2	2.2	0.0	0.0			
	15-3	2.3	0.0	0.0			
	16-1	2.3	0.0	0.0			
	16-2	2.2	0.0	0.0			
	16-3	2.2	0.0	0.0			
	MAX	2.4	0.1	0.2			
	MIN	2.1	-0.1	0.0			
	AVG	2.2	0.0	0.0			
	STD	0.1	0.0	0.0			
	Open	0	0	0			
	Tech	RO	RO	RO			
	Equip ID	413	413	413			
		1047	1047	1047			



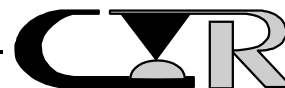
Low Level Contact Resistance					
Project:	201611			Spec:	EIA 364, Tp 23
Customer:	Samtec			Subgroup:	Seq 1 (Brd # G1-4)
Product:	Series PEC connector			File #:	20161104
Description:	PN: PEC-03-02-T-S				
Open circuit voltage:	20mv			Current:	10 ma
Delta values units: milliohms					
Temp °C	23	23	23		
R.H. %	30	25	28		
Date:	04Dec01	10Dec01	13Dec01		
Pos. ID	Initial	M. Shock	Vibration		
1-1	2.5	0.0	0.1		
1-2	2.4	0.0	0.0		
1-3	2.5	0.0	0.1		
2-1	2.7	0.0	0.2		
2-2	2.5	0.0	0.2		
2-3	2.7	0.0	0.4		
3-1	2.6	0.0	0.0		
3-2	2.4	0.0	0.0		
3-3	2.5	0.0	0.0		
4-1	2.5	0.0	0.1		
4-2	2.4	0.0	0.1		
4-3	2.5	0.0	0.1		
5-1	2.5	0.0	0.1		
5-2	2.5	0.0	0.2		
5-3	2.5	0.0	0.2		
6-1	2.5	0.0	0.0		
6-2	2.4	0.0	0.1		
6-3	2.5	0.0	0.0		
7-1	2.5	0.0	0.1		
7-2	2.5	0.0	0.0		
7-3	2.6	0.0	0.1		
8-1	2.4	Open	Open		
8-2	2.4	Open	Open		
8-3	2.5	Open	Open		
9-1	2.5	0.0	0.1		
9-3	2.3	0.0	0.1		
9-4	2.5	0.0	0.1		
10-1	2.4	0.1	0.2		
10-2	2.5	0.0	0.0		
10-3	2.5	0.1	0.1		
11-1	2.5	0.0	0.1		
11-2	2.5	0.0	0.0		
11-3	2.5	0.0	0.0		
12-1	2.5	0.0	0.0		
12-2	2.5	0.0	0.0		



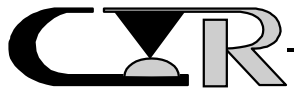
	Temp °C	23	23	23			
	R.H. %	30	25	28			
	Date:	04Dec01	10Dec01	13Dec01			
	Pos. ID	Initial	M. Shock	Vibration			
	12-3	2.6	0.0	0.0			
	13-1	2.5	0.0	0.0			
	13-2	2.4	0.0	0.0			
	13-3	2.5	0.0	0.0			
	14-1	Open	Open	Open			
	14-2	Open	Open	Open			
	14-3	Open	Open	Open			
	15-1	2.4	0.1	0.2			
	15-2	2.5	0.1	0.4			
	15-3	2.5	0.0	0.1			
	16-1	Open	Open	Open			
	16-2	Open	Open	Open			
	16-3	Open	Open	Open			
	MAX	2.7	0.1	0.4			
	MIN	2.3	0.0	0.0			
	AVG	2.5	0.0	0.1			
	STD	0.1	0.0	0.1			
	Open	6	9	9			
	Tech	RO	RO	RO			
	Equip ID	413	413	413			
		1047	1047	1047			



			Low Level Contact Resistance				
Project:	201611				Spec:	EIA 364, Tp 23	
Customer:	Samtec				Subgroup:	Seq 1 (Brd # G1-5)	
Product:	Series PEC connector				File #:	20161105	
Description:	PN: PEC-03-02-T-S						
Open circuit voltage:	20mv				Current:	10 ma	
			Delta values				
			units: milliohms				
Temp °C	23	23	23				
R.H. %	30	25	28				
Date:	04Dec01	10Dec01	13Dec01				
Pos. ID	Initial	M. Shock	Vibration				
	1-1	2.7	0.1	0.2			
	1-2	2.6	0.1	0.1			
	1-3	2.8	0.0	0.1			
	2-1	2.5	0.4	0.5			
	2-2	2.4	0.1	0.2			
	2-3	2.5	0.1	0.2			
	3-1	2.3	0.0	0.0			
	3-2	2.3	0.0	0.0			
	3-3	2.4	0.0	0.0			
	4-1	2.4	0.0	0.3			
	4-2	2.3	0.0	0.1			
	4-3	2.4	0.0	0.1			
	5-1	2.5	0.0	0.0			
	5-2	2.4	0.0	0.0			
	5-3	2.6	0.0	0.0			
	6-1	2.4	0.0	0.1			
	6-2	2.3	0.0	0.0			
	6-3	2.4	0.0	0.0			
	7-1	2.4	0.0	0.1			
	7-2	2.3	0.0	0.1			
	7-3	2.4	0.1	0.2			
	8-1	2.3	0.0	0.0			
	8-2	2.3	0.0	0.1			
	8-3	2.3	0.0	0.1			
	9-1	2.4	0.1	0.2			
	9-2	2.3	0.1	0.2			
	9-3	2.4	0.1	0.1			
	10-1	2.4	0.5	0.8			
	10-2	2.3	0.1	0.1			
	10-3	2.4	0.0	0.2			
	11-1	2.5	0.0	0.0			
	11-2	2.4	0.0	0.0			
	11-3	2.4	0.0	0.0			
	12-1	2.4	0.0	0.0			
	12-2	2.3	0.0	0.0			

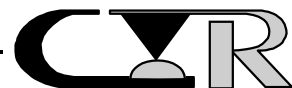


	Temp °C	23	23	23			
	R.H. %	30	25	28			
	Date:	04Dec01	10Dec01	13Dec01			
	Pos. ID	Initial	M. Shock	Vibration			
	12-3	2.4	-0.1	0.0			
	13-1	2.5	0.0	0.0			
	13-2	2.6	-0.3	-0.3			
	13-3	2.4	0.0	0.1			
	14-1	2.4	0.0	0.0			
	14-2	2.3	0.0	0.0			
	14-3	2.4	-0.1	0.0			
	15-1	2.5	-0.2	-0.2			
	15-2	2.6	-0.3	-0.3			
	15-3	2.4	-0.1	0.0			
	16-1	2.4	0.1	0.2			
	16-2	2.4	0.2	0.1			
	16-3	2.3	0.2	0.3			
	MAX	2.8	0.5	0.8			
	MIN	2.3	-0.3	-0.3			
	AVG	2.4	0.0	0.1			
	STD	0.1	0.1	0.2			
	Open	0	0	0			
	Tech	RO	RO	RO			
	Equip	413	413	413			
		1047	1047	1047			



TEST RESULTS

GROUP 2



PROJECT NO.: 201611

SPECIFICATION: N/A

PART NO.: PEC-03-02-T-S

PART DESCRIPTION: Edge Card
Connector

SAMPLE SIZE: ID#G2-1,G2-2,G2-3,
G2-4,G2-5

TECHNICIAN: RO

START DATE: 12/7/01

COMPLETE DATE: 12/7/01

ROOM AMBIENT: 24°C

RELATIVE HUMIDITY: 34%

EQUIPMENT ID#: 413, 1047

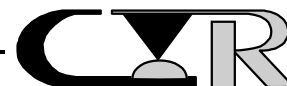
LOW LEVEL CIRCUIT RESISTANCE (LLCR)

PURPOSE:

1. To evaluate contact resistance characteristics of the contact systems under conditions where applied voltages and currents do not alter the physical contact interface and will detect oxides and films which degrade electrical stability. It is also sensitive to and may detect the presence of fretting corrosion induced by mechanical or thermal environments as well as any significant loss of contact pressure.
2. This attribute was monitored after each preconditioning and/or test exposure in order to determine said stability of the contact systems as they progress through the applicable test sequences.
3. The electrical stability of the system is determined by comparing the initial resistance value to that observed after a given test exposure. The difference is the change in resistance occurring whose magnitude establishes the stability of the interface being evaluated.

PROCEDURE:

1. The test was performed in accordance with Samtec's TC0141-0542Flowchart and EIA 364, Test Procedure 23 with the following conditions:



PROCEDURE: Continued

2. Test Conditions:

- a) Test Current : 10 milliamps
- b) Open Circuit Voltage : 20 millivolts
- c) No. of Positions Tested : 3 positions per connector,
16 connectors per board

3. The points of application are shown in Figure #3.

REQUIREMENTS:

Low level circuit resistance shall be measured and recorded.

RESULTS:

1. The following is a summary of the data observed:

LOW LEVEL CIRCUIT RESISTANCE
(Milliohms)

<u>Board ID#</u>	<u>Avg.</u>	<u>Max.</u>	<u>Min.</u>
G2-1	2.6	2.8	2.4
G2-2	2.4	2.7	2.3
G2-3	2.4	2.6	2.2
G2-4	2.5	2.8	2.4
G2-5	2.4	2.9	2.2

2. See data files 20161106 through 20161110 for individual data points.



PROJECT NO.: 201611

SPECIFICATION: N/A

PART NO.: PEC-03-02-T-S

PART DESCRIPTION: Edge Card
Connector

SAMPLE SIZE: ID#G2-1,G2-2,G2-3,
G2-4,G2-5

TECHNICIAN: RO

START DATE: 12/11/01

COMPLETE DATE: 12/11/01

ROOM AMBIENT: 23°C

RELATIVE HUMIDITY: 28%

EQUIPMENT ID#: 20, 413, 1047

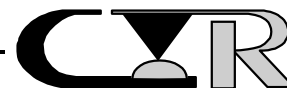
GAS TIGHT

PURPOSE:

To evaluate the integrity of the contact interface by assessment of the gas tight characteristics of the contacting surfaces. The gas tight characteristic is the ability of contacting surfaces to prevent harsh environment from penetrating between them and forming oxides and/or films which will degrade electrical performance.

PROCEDURE:

1. The test environment was performed in accordance with Samtec's TC0141-0542Flowchart and EIA 364, Test Procedure 36.
2. Nitric acid was placed in the test chamber of a sufficient volume to result in saturation of the test chamber. The conditions were room ambient.
3. The solution was allowed to saturate the test chamber for a minimum of 15 minutes.
4. The test samples were placed in the test chamber and exposed for one hour \pm 5.0 minutes.
5. The test samples were placed in such a manner as not to be closer than 1" (25mm) from the wall of the test chamber and not closer than 3" (76mm) from the solution surfaces.



PROCEDURE: Continued

6. After exposure, the samples were removed from the test chamber and oven dried at 50°C for a minimum of one hour.
7. Within 60 minutes of drying, the final low level circuit resistance was measured and recorded. Measurements were performed with the test sample at room ambient.
8. All subsequent variable testing was performed in accordance with the procedures previously indicated.

REQUIREMENTS:

The change in low level circuit resistance shall not exceed +10.0 milliohms.

RESULTS:

1. The following is a summary of the data observed:

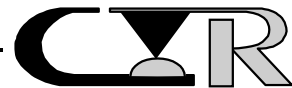
CHANGE IN
LOW LEVEL CIRCUIT RESISTANCE
(Milliohms)

<u>Board ID#</u>	<u>Avg. Change</u>	<u>Max. Change</u>
G2-1	+0.0	+0.1
G2-2	+0.0	+0.1
G2-3	+0.0	+0.1
G2-4	+0.0	+0.2
G2-5	+0.0	+0.5

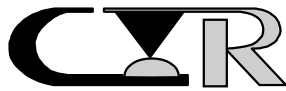
4. See data files 20161106 through 20161110 for individual data points.



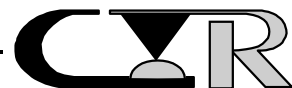
	Temp °C	24	23				
	R.H. %	34	28				
	Date:	07Dec01	11Dec01				
	Pos. ID	Initial	Gas Tight				
	13-3	2.7	0.0				
	14-1	2.8	0.0				
	14-2	2.7	0.0				
	14-3	2.8	0.0				
	15-1	2.7	0.0				
	15-2	2.7	0.0				
	15-3	2.7	0.0				
	16-1	2.7	0.0				
	16-2	2.7	0.1				
	16-3	2.8	0.0				
	MAX	2.8	0.1				
	MIN	2.4	0.0				
	AVG	2.6	0.0				
	STD	0.1	0.0				
	Open	0	0				
	Tech	RO	RO				
	Equip ID	413	413				
		1047	1047				



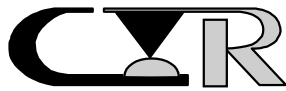
	Temp °C	24	23				
	R.H. %	34	28				
	Date:	07Dec01	11Dec01				
	Pos. ID	Initial	Gas Tight				
	12-3	2.4	0.0				
	13-1	2.3	0.0				
	13-2	2.3	0.0				
	13-3	2.3	0.0				
	14-1	2.5	0.0				
	14-2	2.3	0.0				
	14-3	2.4	0.0				
	15-1	2.3	0.0				
	15-2	2.3	0.0				
	15-3	2.3	0.0				
	16-1	2.6	0.0				
	16-2	2.5	0.0				
	16-3	2.5	0.0				
	MAX	2.7	0.1				
	MIN	2.3	0.0				
	AVG	2.4	0.0				
	STD	0.1	0.0				
	Open	0	0				
	Tech	RO	RO				
	Equip ID	413	413				
		1047	1047				



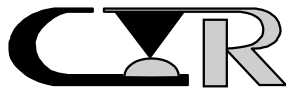
	Temp °C	24	23				
	R.H. %	34	28				
	Date:	07Dec01	11Dec01				
	Pos. ID	Initial	Gas Tight				
	12-3	2.4	0.0				
	13-1	2.4	0.0				
	13-2	2.3	0.0				
	13-3	2.4	0.0				
	14-1	2.5	-0.2				
	14-2	2.4	0.0				
	14-3	2.5	0.1				
	15-1	2.3	0.0				
	15-2	2.3	0.0				
	15-3	2.4	0.1				
	16-1	2.4	0.1				
	16-2	2.3	0.1				
	16-3	2.3	0.1				
	MAX	2.6	0.1				
	MIN	2.2	-0.2				
	AVG	2.4	0.0				
	STD	0.1	0.0				
	Open	0	0				
	Tech	RO	RO				
	Equip ID	413	413				
		1047	1047				



	Temp °C	24	23				
	R.H. %	34	28				
	Date:	07Dec01	11Dec01				
	Pos. ID	Initial	Gas Tight				
	12-3	2.6	0.1				
	13-1	2.6	0.0				
	13-2	2.5	0.0				
	13-3	2.5	0.0				
	14-1	2.6	0.0				
	14-2	2.5	0.0				
	14-3	2.6	0.0				
	15-1	2.5	0.0				
	15-2	2.5	0.0				
	15-3	2.5	0.0				
	16-1	2.5	0.0				
	16-2	2.4	0.1				
	16-3	2.5	0.0				
	MAX	2.8	0.2				
	MIN	2.4	0.0				
	AVG	2.5	0.0				
	STD	0.1	0.0				
	Open	0	0				
	Tech	RO	RO				
	Equip ID	413	413				
		1047	1047				

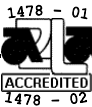


	Temp °C	24	23				
	R.H. %	34	28				
	Date:	07Dec01	11Dec01				
	Pos. ID	Initial	Gas Tight				
	12-3	2.4	0.0				
	13-1	2.5	0.0				
	13-2	2.4	0.0				
	13-3	2.5	0.0				
	14-1	2.4	0.1				
	14-2	2.3	0.0				
	14-3	2.3	0.0				
	15-1	2.6	0.2				
	15-2	2.6	0.0				
	15-3	2.9	-0.4				
	16-1	2.2	0.5				
	16-2	2.2	0.4				
	16-3	2.4	-0.1				
	MAX	2.9	0.5				
	MIN	2.2	-0.4				
	AVG	2.4	0.0				
	STD	0.1	0.1				
	Open	0	0				
	Tech	RO	RO				
	Equip ID	413	413				
		1047	1047				



TEST RESULTS

GROUP 3



PROJECT NO.: 201611 SPECIFICATION: N/A

PART NO.: PEC-03-02-T-S PART DESCRIPTION: Edge Card Connector

SAMPLE SIZE: ID#G3-1,G3-2,G3-3, TECHNICIAN: RO
G3-4,G3-5

START DATE: 11/20/01 COMPLETE DATE: 12/11/01

ROOM AMBIENT: 24°C RELATIVE HUMIDITY: 36%

EQUIPMENT ID#: 164, 235, 410, 440, 580, 584, 1279

CURRENT CYCLING

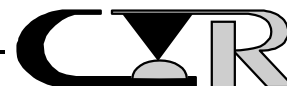
PURPOSE:

To determine the impact of cycling a given current ('on' and 'off') relative to the electrical performance of the connector.

PROCEDURE:

1. The test was performed in accordance with Samtec's TC0141-0542Flowchart and EIA 364, Test Procedure 55, Test Condition B, Method 4.
2. Test Conditions:
 - a) Current Level : 3.75 amps
 - b) 'ON' Cycle : 45 minutes
 - c) 'OFF' Cycle : 15 minutes
 - d) Duration : 500 Hours
3. The test samples were prepared to accept thermocouples at the appropriate locations.
4. The test samples were wired in a series circuit as illustrated in Figure #8.
5. To ensure the samples would not experience an electrical or thermo "runaway" during the current cycle test, the voltage drop across the samples and the temperature rise was recorded twice a day throughout the test.

REQUIREMENTS: See next page.



REQUIREMENTS:

1. There shall be no evidence of physical damage to the test samples as tested.
2. The Voltage Drop and Temperature Rise shall be measured and recorded.

RESULTS:

1. There was no evidence of physical damage to the test samples as tested.
2. The following is a summary of the Temperature Rise data observed recorded during the 500 hour test:

TEMPERATURE RISE
(Degree C)

<u>Board ID#</u>	<u>Avg.</u>	<u>Max.</u>	<u>Min.</u>
G3-1	+12.2°C	+13.6°C	+11.0°C
G3-2	+10.2°C	+13.9°C	+8.8°C

3. See data file 20161101T for individual data points.
4. The following is a summary of the observed Voltage Drop data recorded during the 500 hour test:

VOLTAGE DROP
(Millivolts)

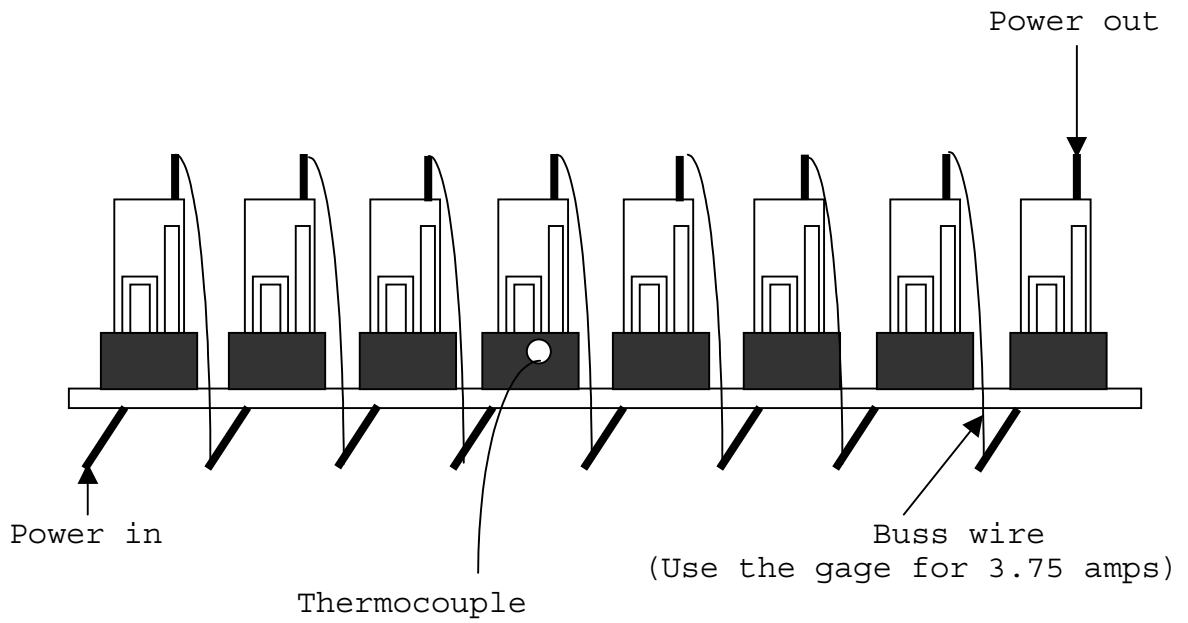
<u>Board ID#</u>	<u>Avg.</u>	<u>Max.</u>	<u>Min.</u>
G3-1, G3-2	20.2	25.8	18.2

5. See data file 20161101V for individual data points.

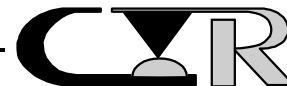


FIGURE #8

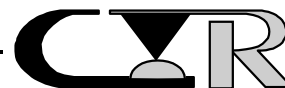
CURRENT CYCLING SET-UP



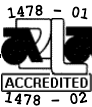
CURRENT CYCLING TEST				
Project #:	201611			
Customer:	Samtec			
Product:	Series PEC Connector			
Description:	PEC-03-02-T-S			
Technician:	RO			
Spec:	EIA 364 TP 55			
Subgroup:	3			
File#:	20161101.CCP			
TC Type:	J			
Current:	3.75 AMPS			
Temperature Rise Data (C) ambient				
TIME	AMB	ID# G3-1	ID# G3-2	
13:10:45	22.5	13.6	13.7	
14:10:45	22.6	13.6	13.9	
15:10:45	22.8	13.2	13.8	
16:10:45	23.0	13.5	13.1	
17:10:45	22.9	13.3	12.9	
18:10:45	22.8	13.3	13.1	
19:10:45	22.6	13.2	12.7	
20:10:45	22.4	12.9	12.0	
21:10:45	22.3	13.1	12.8	
22:10:45	22.2	12.8	10.3	
23:10:45	22.3	12.6	10.5	
0:10:45	22.0	13.1	10.3	
1:10:45	21.9	12.8	10.5	
2:10:45	21.9	12.6	10.5	
3:10:45	21.8	12.6	10.6	
4:10:45	21.9	12.5	10.6	
5:10:45	21.7	12.7	10.4	
6:10:45	21.8	12.4	10.2	
7:10:45	21.7	12.5	10.4	
8:10:45	21.5	12.7	10.9	
9:10:45	21.6	12.7	10.3	
10:10:45	21.9	12.8	10.5	
11:10:45	22.4	13.6	10.4	
12:10:45	22.7	13.3	10.6	
13:10:45	22.8	13.2	10.4	
14:10:45	22.9	13.3	10.6	
15:10:45	22.9	13.2	10.5	
16:10:45	22.9	13.0	10.3	
17:10:45	22.4	13.3	9.9	
18:10:45	22.3	13.1	10.0	
19:10:45	22.3	13.0	10.0	
20:10:45	22.0	13.2	10.2	
21:10:45	22.1	13.0	10.6	
22:10:45	22.1	13.1	10.0	
23:10:45	21.9	13.3	10.0	
0:10:45	21.9	12.8	10.5	
1:10:45	21.6	13.2	10.1	
2:10:45	21.7	13.0	10.3	
3:10:45	21.8	12.9	10.2	



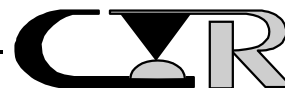
	TIME	AMB	ID# G3-1	ID# G3-2				
	4:10:45	21.5	13.1	10.3				
	5:10:45	21.5	13.0	10.4				
	6:10:45	21.4	12.9	10.3				
	7:10:45	21.2	13.2	10.4				
	8:10:45	21.2	13.1	10.5				
	9:10:45	21.4	12.7	10.6				
	10:10:45	21.5	13.1	10.1				
	11:10:45	21.6	13.1	10.6				
	12:10:45	21.8	13.2	10.1				
	13:10:45	21.9	13.2	10.1				
	14:10:45	22.2	13.0	10.0				
	15:10:45	22.2	13.1	9.7				
	16:10:45	22.2	12.9	10.0				
	17:10:45	22.1	12.9	9.6				
	18:10:45	21.8	12.8	9.9				
	19:10:45	21.7	13.0	9.9				
	20:10:45	21.8	12.8	10.2				
	21:10:45	21.5	12.8	10.3				
	22:10:45	21.5	13.1	10.4				
	23:10:45	21.6	12.8	10.1				
	0:10:45	21.4	12.9	9.8				
	1:10:45	21.3	13.0	10.3				
	2:10:45	21.3	13.0	10.4				
	3:10:45	21.2	12.9	10.3				
	4:10:45	21.1	12.9	10.2				
	5:10:45	21.1	12.9	10.0				
	6:10:45	21.3	12.8	9.8				
	7:10:45	21.5	12.6	10.0				
	8:10:45	21.5	12.6	10.4				
	9:10:45	21.4	13.0	10.4				
	10:10:45	21.6	13.1	10.0				
	11:10:45	21.8	12.9	10.4				
	12:10:45	22.1	12.6	10.2				
	13:10:45	22.3	12.8	10.0				
	14:10:45	22.5	12.7	10.2				
	15:10:45	22.5	13.0	10.3				
	16:10:45	22.5	12.9	10.2				
	17:10:45	22.4	12.4	10.2				
	18:10:45	22.3	12.5	10.0				
	19:10:45	22.1	12.7	10.8				
	20:10:45	21.9	12.9	10.0				
	21:10:45	21.9	12.6	10.2				
	22:10:45	21.9	12.4	10.4				
	23:10:45	21.9	12.5	10.1				
	0:10:45	21.8	12.5	10.5				
	1:10:45	21.7	12.2	10.2				
	2:10:45	21.7	12.1	10.0				
	3:10:45	21.7	11.9	10.2				
	4:10:45	21.7	11.9	10.2				



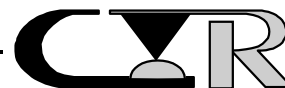
	TIME	AMB	ID# G3-1	ID# G3-2				
	5:10:45	21.6	11.5	9.9				
	6:10:45	21.6	11.6	10.1				
	7:10:45	21.6	11.9	9.9				
	8:10:45	21.6	11.8	10.2				
	9:10:45	21.8	11.7	10.3				
	10:10:45	21.8	11.6	10.3				
	11:10:45	21.9	11.9	9.7				
	12:10:45	22.0	12.0	10.3				
	13:10:45	21.9	11.7	9.8				
	14:10:45	21.8	11.9	10.1				
	15:10:45	22.0	11.6	10.1				
	16:10:45	21.8	11.9	10.5				
	17:10:45	21.8	11.8	9.8				
	18:10:45	21.8	11.4	10.6				
	19:10:45	21.8	11.5	10.5				
	20:10:45	21.9	11.7	10.3				
	21:10:45	21.8	11.6	10.5				
	22:10:45	22.0	11.6	9.7				
	23:10:45	21.8	11.5	10.5				
	0:10:45	21.7	11.6	10.4				
	1:10:45	21.7	11.7	10.2				
	2:10:45	21.7	11.8	10.3				
	3:10:45	21.7	11.5	10.1				
	4:10:45	21.5	12.1	10.1				
	5:10:45	21.6	11.7	10.2				
	6:10:45	21.6	11.7	10.1				
	7:10:45	21.5	11.8	10.0				
	8:10:45	21.5	11.8	10.5				
	9:10:45	21.7	11.7	10.4				
	10:10:45	21.9	11.8	10.1				
	11:10:45	22.3	11.6	9.8				
	12:10:45	22.4	12.1	10.4				
	13:10:45	22.5	11.9	9.8				
	14:10:45	22.5	11.6	10.0				
	15:10:45	22.3	12.2	10.3				
	16:10:45	22.3	11.3	10.1				
	17:10:45	22.1	11.4	10.1				
	18:10:45	22.1	11.4	10.2				
	19:10:45	22.2	11.4	9.9				
	20:10:45	22.0	11.7	10.0				
	21:10:45	22.0	11.4	10.3				
	22:10:45	22.0	11.9	10.3				
	23:10:45	22.0	11.6	10.5				
	0:10:45	22.0	11.8	10.6				
	1:10:45	22.0	11.9	10.1				
	2:10:45	22.0	11.7	10.4				
	3:10:45	22.0	11.4	10.4				
	4:10:45	22.0	11.9	10.3				
	5:10:45	22.1	11.5	10.6				



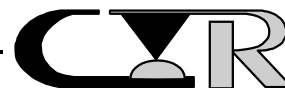
	TIME	AMB	ID# G3-1	ID# G3-2				
	6:10:45	22.1	12.0	10.5				
	7:10:45	22.2	12.0	10.5				
	8:10:45	22.2	11.9	10.3				
	9:10:45	22.1	12.2	10.7				
	10:10:45	22.3	11.9	10.2				
	11:10:45	22.3	11.3	10.7				
	12:10:45	22.6	11.4	10.9				
	13:10:45	22.8	11.7	10.0				
	14:10:45	23.1	11.8	9.7				
	15:10:45	23.2	11.7	9.7				
	16:10:45	23.0	11.9	10.2				
	17:10:45	23.1	12.1	10.3				
	18:10:45	22.9	11.6	10.1				
	19:10:45	22.7	11.3	10.3				
	20:10:45	22.6	11.9	10.3				
	21:10:45	22.4	11.7	10.4				
	22:10:45	22.4	11.9	10.6				
	23:10:45	22.3	11.3	10.3				
	0:10:45	22.3	11.8	10.3				
	1:10:45	22.2	11.3	10.6				
	2:10:45	22.2	11.8	10.4				
	3:10:45	22.3	11.8	10.1				
	4:10:45	22.2	11.6	10.8				
	5:10:45	22.1	11.5	10.5				
	6:10:45	22.1	11.3	10.7				
	7:10:45	22.1	11.5	10.2				
	8:10:45	22.0	11.8	10.0				
	9:10:45	22.3	11.4	10.1				
	10:10:45	22.8	11.8	10.5				
	11:10:45	23.0	12.1	10.0				
	12:10:45	23.1	11.5	10.3				
	13:10:45	23.1	11.5	10.5				
	14:10:45	23.1	11.5	10.3				
	15:10:45	23.2	11.9	10.4				
	16:10:45	23.1	11.6	10.4				
	17:10:45	23.2	11.7	9.8				
	18:10:45	23.1	11.8	10.1				
	19:10:45	22.8	12.1	10.1				
	20:10:45	22.7	12.2	10.2				
	21:10:45	22.6	11.9	10.1				
	22:10:45	22.4	11.9	10.1				
	23:10:45	22.4	12.0	10.3				
	0:10:45	22.4	11.9	10.5				
	1:10:45	22.3	12.0	10.8				
	2:10:45	22.3	12.1	11.0				
	3:10:45	22.2	12.2	11.0				
	4:10:45	22.3	11.9	10.6				
	5:10:45	22.1	12.1	11.0				
	6:10:45	22.3	11.9	10.7				



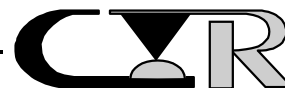
	TIME	AMB	ID# G3-1	ID# G3-2				
	7:10:45	22.1	12.3	10.3				
	8:10:45	22.2	12.0	10.6				
	9:10:45	22.2	12.4	10.2				
	10:10:45	22.7	12.3	10.4				
	11:10:45	23.1	12.1	10.2				
	12:10:45	23.4	12.1	9.9				
	13:10:45	23.6	12.3	10.1				
	14:10:45	23.8	12.2	10.4				
	15:10:45	23.8	12.2	9.8				
	16:10:45	23.8	12.1	9.9				
	17:10:45	23.7	12.2	10.1				
	18:10:45	23.5	12.1	9.8				
	19:10:45	23.1	12.2	10.1				
	20:10:45	23.0	12.2	10.0				
	21:10:45	22.8	12.2	10.7				
	22:10:45	22.8	11.9	10.6				
	23:10:45	22.6	11.9	10.6				
	0:10:45	22.5	12.1	10.7				
	1:10:45	22.4	11.7	10.3				
	2:10:45	22.5	12.0	9.9				
	3:10:45	22.5	12.1	9.9				
	4:10:45	22.4	12.1	9.7				
	5:10:45	22.3	11.8	10.2				
	6:10:45	22.2	11.7	10.3				
	7:10:45	22.1	11.9	10.5				
	8:10:45	22.1	11.9	10.3				
	9:10:45	22.2	11.7	10.3				
	10:10:45	22.1	12.3	9.7				
	11:10:45	22.3	12.0	9.9				
	12:10:45	22.3	12.1	10.5				
	13:10:45	22.5	11.8	10.5				
	14:10:45	22.5	11.9	10.4				
	15:10:45	22.8	12.1	9.8				
	16:10:45	22.8	11.9	9.9				
	17:10:45	22.7	12.3	10.0				
	18:10:45	22.8	12.0	9.9				
	19:10:45	22.7	11.8	10.3				
	20:10:45	22.6	12.0	10.2				
	21:10:45	22.4	12.0	10.0				
	22:10:45	22.4	12.0	9.9				
	23:10:45	22.4	11.6	10.0				
	0:10:45	22.3	11.6	10.0				
	1:10:45	22.3	11.7	9.7				
	2:10:45	22.3	12.1	10.0				
	3:10:45	22.3	12.0	10.0				
	4:10:45	22.2	11.8	10.3				
	5:10:45	22.3	11.9	10.0				
	6:10:45	22.3	11.8	10.0				
	7:10:45	22.3	11.8	10.2				



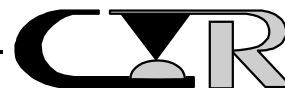
	TIME	AMB	ID# G3-1	ID# G3-2				
	8:10:45	22.4	12.0	10.5				
	9:10:45	22.3	12.0	10.4				
	10:10:45	22.2	12.1	10.1				
	11:10:45	22.3	12.3	10.1				
	12:10:45	22.5	12.4	10.2				
	13:10:45	22.6	12.4	10.6				
	14:10:45	22.8	12.2	10.1				
	15:10:45	22.9	12.4	9.9				
	16:10:45	22.9	12.2	9.5				
	17:10:45	23.0	12.4	10.4				
	18:10:45	22.7	12.2	10.6				
	19:10:45	22.6	12.4	9.9				
	20:10:45	22.5	12.4	10.5				
	21:10:45	22.5	12.0	10.7				
	22:10:45	22.4	12.5	10.6				
	23:10:45	22.4	12.5	10.1				
	0:10:45	22.4	12.3	10.6				
	1:10:45	22.5	12.3	10.6				
	2:10:45	22.4	12.3	10.3				
	3:10:45	22.4	12.5	10.2				
	4:10:45	22.4	12.5	10.7				
	5:10:45	22.4	12.2	10.4				
	6:10:45	22.4	12.3	10.2				
	7:10:45	22.4	12.5	10.2				
	8:10:45	22.3	12.5	10.6				
	9:10:45	22.4	12.1	10.2				
	10:10:45	22.5	12.0	10.2				
	11:10:45	22.7	12.3	10.0				
	12:10:45	22.9	12.3	9.8				
	13:10:45	23.1	12.4	10.3				
	14:10:45	23.2	12.5	10.0				
	15:10:45	23.3	12.4	10.0				
	16:10:45	23.3	12.4	10.0				
	17:10:45	23.1	12.4	10.1				
	18:10:45	22.9	12.3	10.4				
	19:10:45	22.8	12.0	9.9				
	20:10:45	22.7	11.9	10.0				
	21:10:45	22.6	11.9	10.7				
	22:10:45	22.6	12.5	10.7				
	23:10:45	22.5	12.0	10.3				
	0:10:45	22.5	12.4	10.8				
	1:10:45	22.5	12.5	10.2				
	2:10:45	22.5	12.3	10.9				
	3:10:45	22.4	12.3	10.3				
	4:10:45	22.3	12.5	11.1				
	5:10:45	22.3	12.3	11.0				
	6:10:45	22.1	12.6	10.3				
	7:10:45	22.4	12.1	10.8				
	8:10:45	22.3	12.0	10.5				



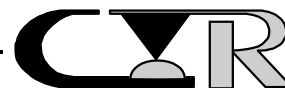
	TIME	AMB	ID# G3-1	ID# G3-2				
	9:10:45	22.1	12.5	10.4				
	10:10:45	22.2	12.4	10.4				
	11:10:45	22.4	11.8	10.5				
	12:10:45	22.3	12.3	10.3				
	13:10:45	22.3	12.6	10.6				
	14:10:45	22.2	12.8	10.9				
	15:10:45	22.2	12.4	10.5				
	16:10:45	22.1	12.5	10.5				
	17:10:45	22.2	12.3	10.6				
	18:10:45	22.0	12.4	10.6				
	19:10:45	22.0	11.9	10.3				
	20:10:45	22.1	12.2	10.7				
	21:10:45	21.9	12.1	10.4				
	22:10:45	22.1	12.1	10.9				
	23:10:45	21.9	12.3	10.5				
	0:10:45	21.7	12.3	11.0				
	1:10:45	21.9	12.1	10.7				
	2:10:45	21.8	12.2	10.5				
	3:10:45	21.9	11.8	10.5				
	4:10:45	21.5	12.1	10.9				
	5:10:45	21.6	12.2	11.0				
	6:10:45	21.8	12.0	10.7				
	7:10:45	21.5	12.0	10.8				
	8:10:45	21.4	12.1	11.1				
	9:10:45	21.8	12.3	10.6				
	10:10:45	22.4	12.3	10.6				
	11:10:45	22.7	12.6	10.0				
	12:10:45	23.0	12.6	10.9				
	13:10:45	23.3	12.4	10.6				
	14:10:45	23.5	12.4	10.2				
	15:10:45	23.4	12.7	10.1				
	16:10:45	23.4	12.0	10.2				
	17:10:45	23.4	12.0	9.5				
	18:10:45	22.9	12.0	9.9				
	19:10:45	22.6	12.4	9.9				
	20:10:45	22.5	12.5	10.7				
	21:10:45	22.6	12.3	10.6				
	22:10:45	22.4	12.3	10.3				
	23:10:45	22.1	12.7	11.0				
	0:10:45	22.1	12.7	10.9				
	1:10:45	22.0	12.6	11.0				
	2:10:45	22.0	12.6	10.7				
	3:10:45	22.2	12.2	10.7				
	4:10:45	21.9	12.5	10.7				
	5:10:45	21.8	12.3	10.5				
	6:10:45	21.8	12.5	10.5				
	7:10:45	21.7	12.5	10.4				
	8:10:45	21.6	12.6	11.0				
	9:10:45	22.0	12.4	11.0				



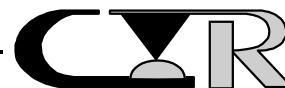
	TIME	AMB	ID# G3-1	ID# G3-2				
	10:10:45	22.4	12.2	10.2				
	11:10:45	22.9	12.5	10.1				
	12:10:45	23.2	12.1	9.7				
	13:10:45	23.5	12.4	9.5				
	14:10:45	23.6	12.3	10.5				
	15:10:45	23.7	12.4	10.0				
	16:10:45	23.7	12.4	10.0				
	17:10:45	23.7	12.4	10.1				
	18:10:45	23.4	12.3	9.9				
	19:10:45	23.2	12.5	10.3				
	20:10:45	23.0	12.2	9.7				
	21:10:45	22.7	12.4	10.2				
	22:10:45	22.6	12.3	9.9				
	23:10:45	22.5	12.4	10.4				
	0:10:45	22.6	12.2	10.5				
	1:10:45	22.5	12.3	10.3				
	2:10:45	22.7	12.3	10.6				
	3:10:45	22.3	12.4	10.1				
	4:10:45	22.5	12.1	10.7				
	5:10:45	22.5	12.0	10.7				
	6:10:45	22.3	12.4	10.2				
	7:10:45	22.3	12.2	10.5				
	8:10:45	22.3	12.4	11.1				
	9:10:45	22.3	12.3	10.5				
	10:10:45	22.7	11.9	9.8				
	11:10:45	22.9	12.4	9.8				
	12:10:45	23.1	12.5	9.7				
	13:10:45	23.3	12.5	9.8				
	14:10:45	23.6	12.6	9.7				
	15:10:45	23.6	12.5	9.5				
	16:10:45	23.7	12.5	9.6				
	17:10:45	23.8	12.5	9.7				
	18:10:45	23.6	12.5	10.7				
	19:10:45	23.3	12.5	9.9				
	20:10:45	23.1	12.5	10.3				
	21:10:45	23.0	12.6	9.8				
	22:10:45	23.0	12.4	10.4				
	23:10:45	22.9	12.4	9.5				
	0:10:45	22.8	12.7	10.0				
	1:10:45	22.8	12.5	9.7				
	2:10:45	22.8	12.5	10.2				
	3:10:45	22.7	12.5	9.6				
	4:10:45	22.6	12.7	9.8				
	5:10:45	22.7	12.6	9.6				
	6:10:45	22.6	12.7	9.8				
	7:10:45	22.6	12.6	9.8				
	8:10:45	22.5	12.2	9.9				
	9:10:45	22.5	12.7	10.0				
	10:10:45	23.2	12.4	9.3				



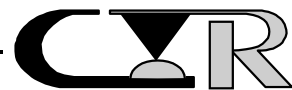
	TIME	AMB	ID# G3-1	ID# G3-2				
	11:10:45	23.5	12.5	9.4				
	12:10:45	23.8	12.5	9.4				
	13:10:45	23.9	12.6	9.4				
	14:10:45	24.0	12.6	9.4				
	15:10:45	24.2	12.3	9.3				
	16:10:45	24.0	12.4	9.4				
	17:10:45	23.8	12.1	10.0				
	18:10:45	23.8	12.3	9.3				
	19:10:45	23.5	12.5	9.5				
	20:10:45	23.4	12.4	9.4				
	21:10:45	23.2	12.5	9.5				
	22:10:45	23.2	12.4	9.0				
	23:10:45	23.1	12.4	9.1				
	0:10:45	23.0	12.4	9.2				
	1:10:45	23.0	12.3	9.4				
	2:10:45	22.9	12.2	9.4				
	3:10:45	22.9	12.0	9.4				
	4:10:45	22.8	12.0	9.8				
	5:10:45	22.8	12.5	9.6				
	6:10:45	22.8	12.5	10.4				
	7:10:45	22.8	12.5	9.8				
	8:10:45	22.8	12.5	10.4				
	9:10:45	22.6	12.5	9.9				
	10:10:45	23.1	12.6	9.6				
	11:10:45	23.3	12.5	9.4				
	12:10:45	23.5	12.7	9.4				
	13:10:45	23.6	12.6	9.7				
	14:10:45	23.8	12.6	9.3				
	15:10:45	23.8	12.3	9.8				
	16:10:45	23.7	12.6	9.6				
	17:10:45	23.6	12.4	9.2				
	18:10:45	23.3	12.4	9.0				
	19:10:45	23.1	12.5	9.4				
	20:10:45	23.0	12.6	9.5				
	21:10:45	23.0	12.7	10.1				
	22:10:45	23.0	12.4	10.4				
	23:10:45	22.9	12.6	10.1				
	0:10:45	22.7	12.8	9.9				
	1:10:45	22.6	12.8	10.0				
	2:10:45	22.5	12.5	10.6				
	3:10:45	22.6	12.8	10.2				
	4:10:45	22.6	12.3	9.8				
	5:10:45	22.3	12.4	10.5				
	6:10:45	22.2	12.7	10.4				
	7:10:45	22.4	12.2	10.4				
	8:10:45	22.5	12.3	9.5				
	9:10:45	22.3	12.6	10.4				
	10:10:45	22.5	12.9	10.6				
	11:10:45	22.8	12.2	9.4				



	TIME	AMB	ID# G3-1	ID# G3-2				
	12:10:45	22.7	12.5	9.5				
	13:10:45	22.6	12.6	10.0				
	14:10:45	22.6	12.4	9.6				
	15:10:45	22.4	12.6	9.7				
	16:10:45	22.2	12.7	9.8				
	17:10:45	22.5	12.2	10.3				
	18:10:45	22.3	12.4	9.8				
	19:10:45	22.2	12.6	10.1				
	20:10:45	22.1	12.6	10.4				
	21:10:45	22.2	12.3	10.3				
	22:10:45	22.0	12.7	10.0				
	23:10:45	22.0	12.5	9.9				
	0:10:45	21.8	12.3	10.2				
	1:10:45	22.0	11.9	10.0				
	2:10:45	21.7	12.5	10.2				
	3:10:45	21.7	12.4	10.1				
	4:10:45	21.7	11.7	9.4				
	5:10:45	21.7	12.2	9.7				
	6:10:45	21.5	11.7	9.7				
	7:10:45	21.7	11.9	10.1				
	8:10:45	21.8	11.8	9.5				
	9:10:45	21.9	11.7	10.0				
	10:10:45	21.7	12.0	10.1				
	11:10:45	22.1	11.9	9.7				
	12:10:45	21.7	12.0	10.2				
	13:10:45	21.9	11.8	10.1				
	14:10:45	21.6	12.1	9.4				
	15:10:45	21.7	11.9	9.5				
	16:10:45	21.6	12.0	10.1				
	17:10:45	21.5	11.8	9.9				
	18:10:45	21.3	11.8	10.0				
	19:10:45	21.5	11.5	10.1				
	20:10:45	21.3	11.9	9.7				
	21:10:45	21.2	11.8	9.9				
	22:10:45	21.0	11.8	9.9				
	23:10:45	21.0	11.7	9.6				
	0:10:45	20.9	11.8	9.8				
	1:10:45	21.1	12.0	9.3				
	2:10:45	21.0	11.2	9.2				
	3:10:45	20.6	11.9	10.0				
	4:10:45	20.7	11.6	9.8				
	5:10:45	20.6	11.6	9.5				
	6:10:45	20.5	11.7	9.7				
	7:10:45	20.4	11.8	9.8				
	8:10:45	20.3	11.9	9.9				
	9:10:45	20.6	11.8	10.0				
	10:10:45	21.3	11.7	9.3				
	11:10:45	21.5	11.8	9.5				
	12:10:45	22.2	11.5	8.8				



	TIME	AMB	ID# G3-1	ID# G3-2				
	13:10:45	22.2	11.9	9.1				
	14:10:45	22.5	11.9	9.9				
	15:10:45	22.5	11.9	9.5				
	16:10:45	22.5	11.8	9.5				
	17:10:45	22.3	11.9	9.7				
	18:10:45	22.0	11.7	9.6				
	19:10:45	21.8	11.8	9.2				
	20:10:45	21.8	11.9	10.1				
	21:10:45	21.8	11.8	9.2				
	22:10:45	21.8	11.9	9.8				
	23:10:45	21.9	11.7	9.3				
	0:10:45	21.9	11.6	9.9				
	1:10:45	21.7	11.7	9.9				
	2:10:45	21.7	11.7	9.6				
	3:10:45	21.6	11.7	9.8				
	4:10:45	21.6	11.8	9.5				
	5:10:45	21.6	11.9	9.6				
	6:10:45	21.6	11.6	9.1				
	7:10:45	21.7	11.6	10.1				
	8:10:45	22.2	11.0	9.0				
	AVERAGE	22.3	12.2	10.2				
	MAXIMUM	24.2	13.6	13.9				
	MINIMUM	20.3	11.0	8.8				



Voltage Drop																								
Project:		201611															Spec:							
Customer:		Samtec															Subgroup:		Seq 3					
Product:		Series PEC connector															File #:		20161101V					
Description:		PN: PEC-03-02-T-S																						
Actual values																								
units: millivolts																								
Temp°C	24	23	23	23	23	23	23	24	24	23	23	23	22	22	23	23	23	23	24	24	24	24	23	23
R.H. %	36	23	23	41	41	34	34	37	37	30	40	40	30	30	30	30	37	37	34	34	38	38	25	25
Date:	20Nov 2001	21Nov 2001	21Nov 2001	26Nov 2001	26Nov 2001	27Nov 2001	27Nov 2001	28Nov 2001	28Nov 2001	29Nov 2001	30Nov 2001	30Nov 2001	03Dec 2001	03Dec 2001	04Dec 2001	04Dec 2001	05Dec 2001	05Dec 2001	06Dec 2001	06Dec 2001	07Dec 2001	07Dec 2001	10Dec 2001	10Dec 2001
Pos. ID	PM	AM	PM	AM	PM	AM	PM	AM	PM	AM	AM	PM	AM	PM	AM	PM	AM	PM	AM	PM	AM	PM	AM	PM
1-1	19.2	19.1	18.9	19.1	19.4	19.5	19.2	19.3	19.4	19.4	19.5	19.5	20.1	19.7	19.5	19.5	19.6	19.8	19.6	19.6	19.3	19.6	19.0	19.0
1-2	18.8	19.2	18.7	18.8	18.8	19.0	18.8	19.0	19.2	19.1	19.3	19.4	19.5	19.6	19.3	19.2	19.3	19.4	19.4	19.3	19.0	19.2	18.7	18.7
1-3	19.5	19.2	19.3	19.2	20.0	19.9	19.4	19.6	19.7	19.6	19.8	19.8	20.3	19.9	20.1	19.8	19.9	19.9	19.8	19.8	19.6	19.9	19.2	19.1
1-4	20.1	19.3	19.4	19.3	19.3	19.5	19.5	19.6	19.8	19.9	19.9	20.0	20.0	20.0	20.0	19.9	19.9	19.9	20.2	19.9	19.7	19.8	19.3	19.5
1-5	19.6	19.0	19.0	19.1	19.1	19.3	19.4	19.5	19.7	18.8	19.9	19.8	20.1	19.9	19.8	19.8	19.8	19.8	19.6	19.5	19.4	19.5	19.2	19.1
1-6	20.3	19.5	19.6	19.7	19.7	20.3	20.0	20.1	20.1	20.1	20.9	20.3	20.3	20.4	20.5	20.4	20.3	20.4	20.2	20.3	20.2	20.3	19.9	19.9
1-7	19.6	18.9	19.1	19.6	19.0	19.2	19.3	19.3	19.4	19.4	19.5	19.6	19.9	19.5	19.3	19.4	19.4	19.4	19.5	19.4	19.4	19.4	19.0	19.2
1-8	21.5	20.8	20.8	20.8	20.7	20.9	19.7	21.2	21.2	21.1	21.9	21.4	21.4	21.4	21.4	21.5	21.3	21.4	21.3	21.2	21.3	21.1	20.7	20.8
2-1	20.8	20.1	20.3	20.2	20.2	20.4	20.6	20.7	20.7	20.6	20.9	20.9	21.1	20.9	20.9	20.8	20.9	20.9	20.9	20.7	21.0	20.7	20.4	20.3
2-2	18.8	18.2	18.5	18.3	18.2	18.4	18.5	19.1	18.7	18.6	18.8	18.8	19.2	18.8	18.9	19.0	18.9	18.5	19.2	18.6	18.8	18.7	18.2	18.5
2-3	20.9	20.1	20.4	20.2	21.5	20.4	20.5	20.7	20.8	20.6	20.9	20.9	21.0	20.9	20.9	20.7	20.8	20.9	20.8	20.8	19.0	20.8	20.4	20.2
2-4	19.5	18.7	18.8	18.8	18.9	19.0	19.2	19.2	19.4	19.2	19.4	19.4	19.6	19.4	19.4	19.5	19.3	19.5	19.3	19.3	20.9	18.3	18.8	18.8
2-5	20.0	19.3	19.4	19.5	19.3	19.6	19.6	19.9	20.0	19.8	20.0	20.1	20.3	19.7	20.0	19.9	19.9	20.0	19.9	19.9	19.9	19.9	19.4	19.5
2-6	20.1	19.8	19.9	19.9	19.7	20.1	20.8	20.4	20.4	20.3	20.5	20.7	20.6	20.6	20.5	20.5	20.4	20.6	20.3	20.4	20.5	20.4	19.8	19.8
2-7	20.6	19.6	19.6	19.6	19.6	19.8	20.1	20.0	20.0	19.9	20.5	20.3	20.4	20.2	20.3	20.3	20.1	20.4	20.1	20.5	20.3	20.2	19.5	19.8
2-8	25.8	24.4	24.6	24.4	24.8	25.0	25.1	25.3	25.7	25.2	25.8	25.3	25.4	25.4	25.5	25.4	25.5	25.4	25.5	25.5	25.7	25.4	24.7	24.1
MAX	25.8	24.4	24.6	24.4	24.8	25.0	25.1	25.3	25.7	25.2	25.8	25.3	25.4	25.4	25.5	25.4	25.5	25.4	25.5	25.5	25.7	25.4	24.7	24.1
MIN	18.8	18.2	18.5	18.3	18.2	18.4	18.5	19.0	18.7	18.6	18.8	18.8	19.2	18.8	18.9	19.0	18.9	18.5	19.2	18.6	18.8	18.3	18.2	18.5
AVG	20.3	19.7	19.8	19.8	19.9	20.0	20.0	20.2	20.3	20.1	20.5	20.4	20.6	20.4	20.5	20.4	20.3	20.4	20.4	20.3	20.3	20.2	19.8	19.8
STD	1.6	1.4	1.4	1.4	1.5	1.5	1.5	1.5	1.6	1.5	1.6	1.5	1.4	1.5	1.5	1.5	1.5	1.5	1.5	1.5	1.6	1.6	1.5	1.3
Tech	RO	RO	RO	RO	RO	RO	RO	RO	RO	RO	RO	RO	RO	RO	RO	RO	RO	RO	RO	RO	RO	RO	RO	RO
Equip ID	184	184	184	184	184	184	184	184	184	184	184	184	184	184	184	184	184	184	184	184	184	184	184	184

