

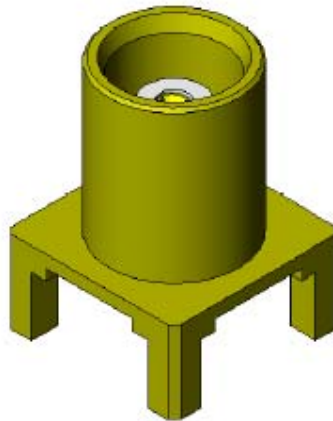

RF Characterization Report

MCX-J-P-H-ST-MT1



Mated with:
RF316-01BJ1-02SP1-0305



Description:
50-Ω MCX Board Mount Jack, Mixed Technology

Series: MCX-MT1

Description: 50-Ω MCX Board Mount Jack, Mixed Technology

Table of Contents

<i>Introduction</i>	1
<i>Product Description</i>	1
<i>Results Summary</i>	3
Frequency Domain Data	3
<i>Test Procedures</i>	5
Fixturing:	5
Return Loss and VSWR Testing	5
Isolation Testing	6
Equipment	7

Series: MCX-MT1**Description:** 50-Ω MCX Board Mount Jack, Mixed Technology

Introduction

This testing was performed to evaluate the electrical performance of the MCX-MT1 50-Ω Board Mount Jack.

Return Loss, VSWR and Isolation measurements were made over the frequency range from 130 MHz to 8.5 GHz for mated pairs of connectors. All measurements were made utilizing a 6-layer test board specifically designed for this project and it is referred to as “test board” in this report. The test board was identified as PCB-102472-TST-02. It had two pairs of MCX-MT1 jacks in a square pattern on 0.39-inch (10 mm) centers. One pair had Layer 3 signal launches, and the other pair had Layer 6 signal launches. The measured results include not only the mated connectors but also the termination and board effects.

Product Description

The test sample was mounted to the test board, which has 50-Ω impedance traces. The connector has an optimized launch (compensation) incorporated into the PCB design to facilitate improved impedance match over the frequency range of interest. The test board traces are approximately one-half inch long and run to field replaceable SMA connectors for connection to the test equipment.

The MCX-MT1 jack was tested by mating it to an MCX plug, which was part of a RF316-01BJ1-02SP1-0305 cable assembly. Two (2) MCX-MT1 jacks were tested. The actual part number that was tested is shown in Table 1. A representative sample picture is shown in Figure 1.

Part Number	Board Mount Connector Type
MCX-J-P-H-ST-MT1	Straight Jack

Table 1: Sample Description

Series: MCX-MT1

Description: 50-Ω MCX Board Mount Jack, Mixed Technology



Figure 1: Test Sample Configuration

Series: MCX-MT1

Description: 50-Ω MCX Board Mount Jack, Mixed Technology

Results Summary

Frequency Domain Data

Return Loss, VSWR and Isolation measurements were performed over the frequency range from 130 MHz to 8.5 GHz. All measurements were performed with the board mount jack mated to a 50-Ω MCX male connector that was part of a 50-Ω flexible cable assembly. The table below lists the worst case Return Loss, VSWR and Isolation of the connector(s) over the frequency range tested.

Board Mount Connector	Launch	Return Loss	VSWR	Isolation
MCX-J-P-H-ST-MT1	Layer 3	-14.5 dB	1.47	-70.1 dB
MCX-J-P-H-ST-MT1	Layer 6	-11.3 dB	1.75	-58.3 dB

Table 2: Return Loss, VSWR & Isolation Worst Case Data

Frequency Domain Data Plots

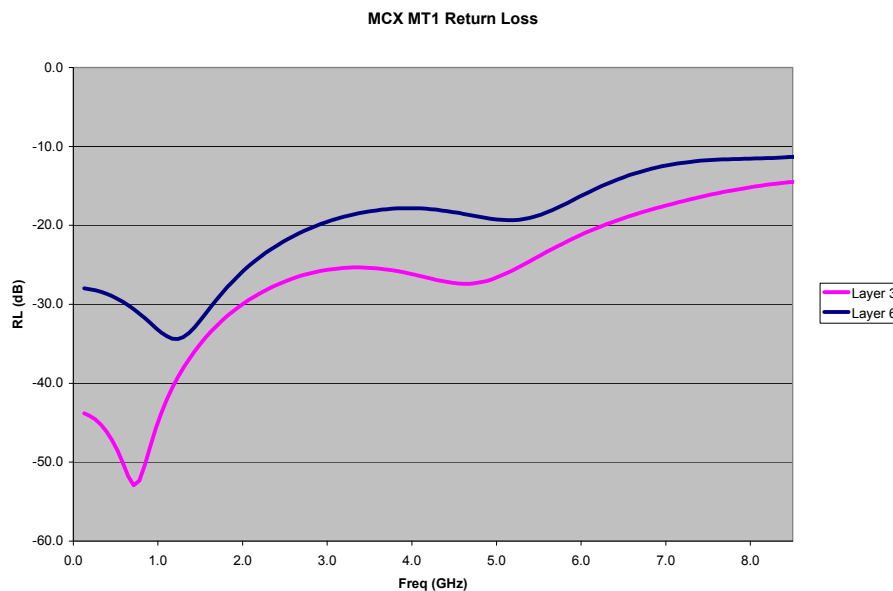

Figure 2: MCX-J-P-H-ST-MT1 Return Loss

Series: MCX-MT1

Description: 50-Ω MCX Board Mount Jack, Mixed Technology

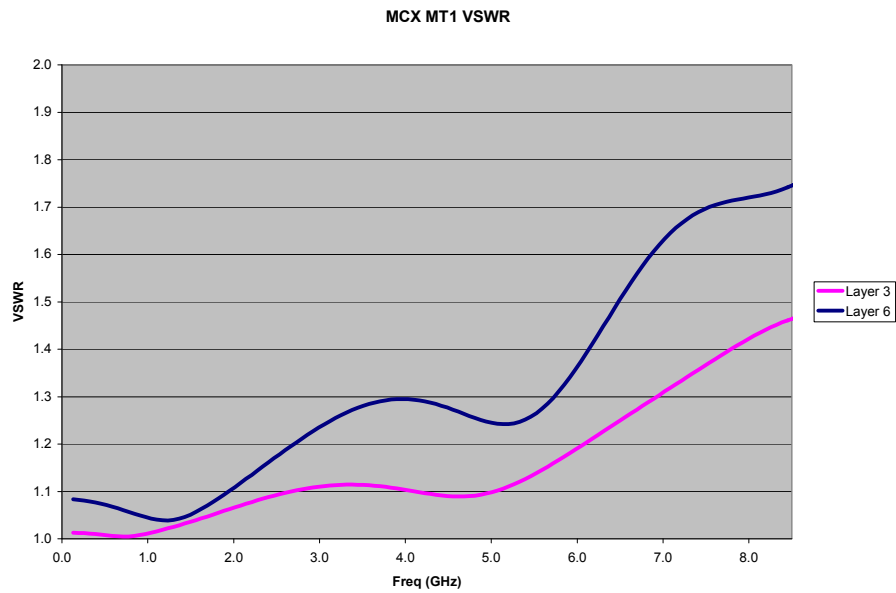

Figure 3: MCX-J-P-H-ST-MT1 VSWR

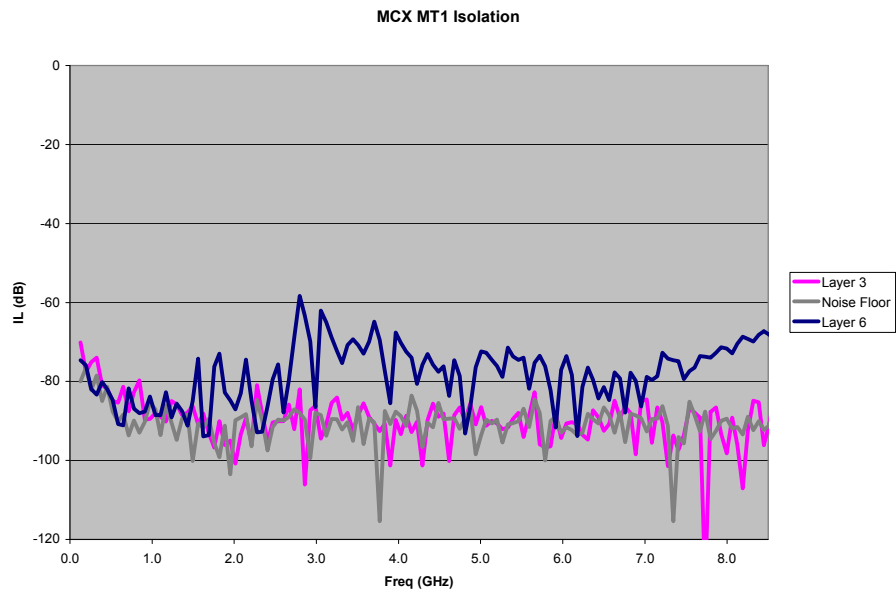

Figure 4: MCX-J-P-H-ST-MT1 Isolation

Series: MCX-MT1

Description: 50-Ω MCX Board Mount Jack, Mixed Technology

Test Procedures

Fixturing:

All measurements were performed using the test board, which has 50-Ω traces (nominal impedance) that connect the MCX-MT1 jacks to field replaceable SMA connectors. During an actual Return Loss or VSWR measurement the MCX-MT1 was mated to a RF316-01BJ1-02SP1-0305 12-inch long 50-Ω flexible cable assembly, which was terminated in a 50-Ω SMA load at its other end.

A vector network analyzer was used to perform the measurements and was connected to the test board field replaceable SMA connector through a 30-inch long 50-Ω SMA (m/m) test cable. The 50-Ω flexible cable MCX (m) connector and the board mount jack comprised the mated connector pair under test.

For the Isolation measurement two RF316-01BJ1-02SP1-0305 12-inch long 50-Ω flexible cable assemblies attached to adjacent (not diagonal) MCX-MT1 jacks. A second 30-inch long 50-Ω SMA (m/m) test cable attached to a second field replaceable SMA.

Return Loss and VSWR Testing

All Return Loss and VSWR measurements were made using an HP 8720A vector network analyzer. It was set for a 201-point measurement response over the frequency range from 130 MHz to 13 GHz to allow use of the low-pass step response time domain transform capability. Response averaging was turned on and set to 8. An S11 1-port measurement calibration was performed at the end of the SMA test cable. The SMA test cable was attached to the test board field replaceable connector, and the MCX-MT1 jack was mated to a RF316-01BJ1-02SP1-0305 12-inch long 50-Ω flexible cable assembly, which was terminated to a 50-Ω SMA load at its other end.

The measured response was viewed in the time domain using the low-pass step transform and the real data format. Gating was turned on. The Gate Start and Stop flags were set around the response of the mated pair of interest. See Figure 5 below. The response format was set to linear magnitude (reflection coefficient), and the time domain transform was turned off (but the gate remained on). In converting back to the frequency domain, the effects of the response outside the Gate are removed. The reflection coefficient data were read by a computer over the GPIB. The data was written in ASCII format to a data

Series: MCX-MT1**Description:** 50-Ω MCX Board Mount Jack, Mixed Technology

file. Data was truncated at 8.5 GHz. The attenuation effects of the 50-Ω test board trace were not taken into account and were a small source of error.

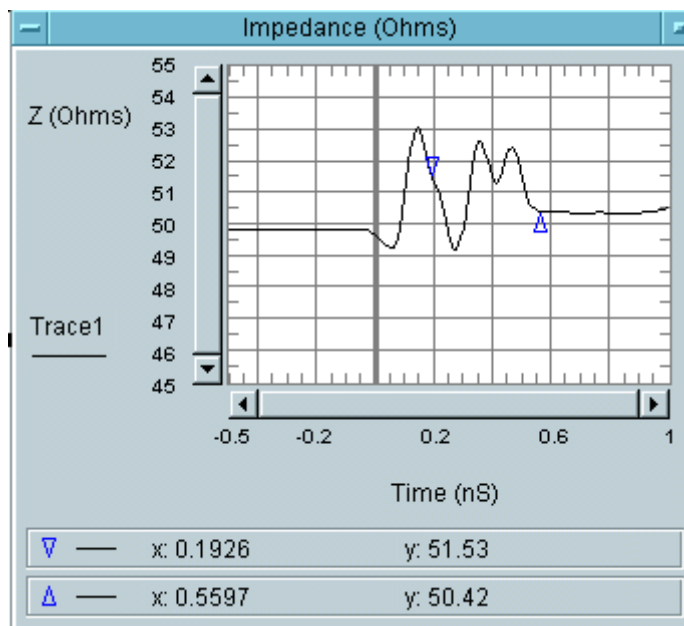

Figure 5. VNA time domain response showing gate placement.

Isolation Testing

The Isolation measurement was made using an HP 8720A vector network analyzer. It was set up the same as for Return Loss and VSWR measurements, except that response averaging was set to 32 and resolution bandwidth was set to 300 Hz to increase dynamic range. An S21 thru response measurement calibration was performed to remove the losses of the two test cables from the measurement. The SMA test cables were attached to the test board field replaceable connectors, and two adjacent MCX-MT1 jacks were mated to RF316-01BJ1-02SP1-0305 12-inch long 50-Ω flexible cable assemblies, which were terminated to 50-Ω SMA loads at their other ends.

The measured response was viewed in log magnitude format. The isolation data were read by a computer over the GPIB, and the data was written in ASCII format to a data file.

Series: MCX-MT1

Description: 50- Ω MCX Board Mount Jack, Mixed Technology

Data was truncated at 8.5 GHz. The attenuation effects of the 50- Ω test board traces were not accounted for and were a small source of error. Also note that coupling effects associated with the test board were included in the measurement.

The test system isolation measurement noise floor was measured by terminating each 30-inch long test cable in a 50- Ω SMA load. The cables were kept apart for this measurement.

Equipment

HP 8720A Network Analyzer