

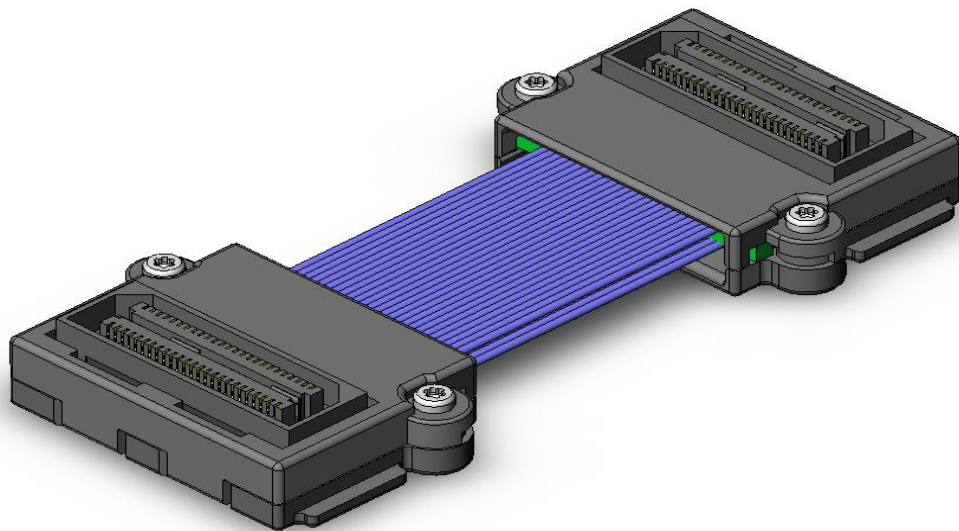

Project Number:		Tracking Code: TC0547--0887				
Requested by: Gary Lewis		Date: 11/17/2005		Product Rev: 1		
Part #: SQCD-025-06.00-STR-TEU-1			Lot #: N/A		Tech: Troy Cook	Eng: Dave Scopelliti
Part description: SQCD					Qty to test: 75	
Test Start: 04/12/2006		Test Completed: 7/27/2006				



**SQCD-0XX-X.XX-XXX-XXX-X
DVT Report**

CERTIFICATION

All instruments and measuring equipment were calibrated to National Institute for Standards and Technology (NIST) traceable standards according to ISO 10012-1 and ANSI/NCSL 2540-1, as applicable.

All contents contained herein are the property of Samtec. No portion of this report, in part or in full shall be reproduced without prior written approval of Samtec.

SCOPE

To perform the following tests: CCC, IR/DWV, FLEX, PULL

APPLICABLE DOCUMENTS

Standards: EIA Publication 364

TEST SAMPLES AND PREPARATION

- 1) All materials were manufactured in accordance with the applicable product specification.
- 2) All test samples were identified and encoded to maintain traceability throughout the test sequences.
- 3) After soldering, the parts to be used for LLCR and DWV/IR testing were cleaned according to TLWI-0001.
- 4) Either an automated cleaning procedure or an ultrasonic cleaning procedure may be used.
- 5) The automated procedure is used with aqueous compatible soldering materials.
- 6) Parts not intended for testing LLCR and DWV/IR are visually inspected and cleaned if necessary.
- 7) Any additional preparation will be noted in the individual test sequences.
- 8) Solder Information: Lead Free
- 9) Re-Flow Time/Temp: See accompanying profile.
- 10) Internal Test PCBs used: PCB-100392-TST-XX

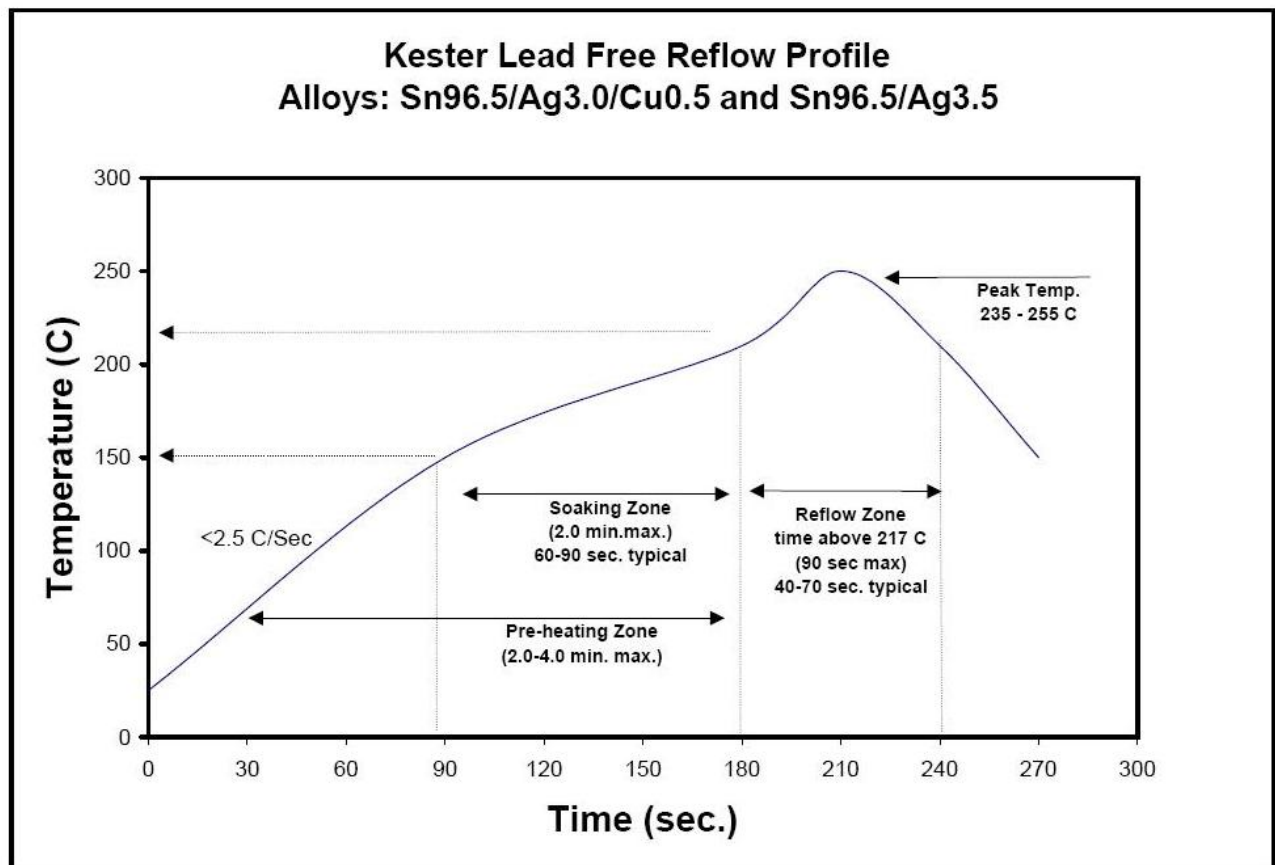
OVEN PROFILE (Soldering Parts to Test Boards)

FLOWCHARTS**Current Carrying Capacity**

TEST STEP	GROUP 1 1 Cable Powered Cable Center	GROUP 2 Both Cables Powered Cable Center
01	CCC	CCC

Tabulate calculated current at RT, 55° C, 65° C and 70° C
after derating 20% and based on 105° C

CCC, Temp rise = EIA-364-70

IR

TEST STEP	GROUP 1A DV Top & Bottom Cable
01	IR
02	Data Review
03	Thermal Aging
04	IR
05	Data Review
06	Humidity
07	IR

Thermal Aging = EIA-364-17, Test Condition 4, 105 deg C;
Time Condition 'B' (250 hours)

Humidity = EIA-364-31, Test Condition B (240 Hours)
and Method III (+25° C to +65° C @ 90%RH to 98% RH)
delete steps 7a and 7b

DWV

TEST STEP	GROUP 1A Top & Bottom Cable Ambient	GROUP 1B Top & Bottom Cable Thermal	GROUP 1C Top & Bottom Cable Humidity
01	DWV/Working Voltage	Thermal Aging	Humidity
02		DWV/Working Voltage	DWV/Working Voltage

Thermal Aging = EIA-364-17, Test Condition 4, 105 deg C;
Time Condition 'B' (250 hours)

Humidity = EIA-364-31, Test Condition B (240 Hours)
and Method III (+25° C to +65° C @ 90%RH to 98% RH)
delete steps 7a and 7b

FLOWCHARTS Continued**Connector Pull**

TEST STEP	GROUP 1A	GROUP 1B
	DV	DV
	GND 0°	GND 90°
01	Pull test, Continuity	Pull test, Continuity

Secure both cables in the center
 Monitor continuity and pull
 record forces when continuity fails.

Resistance, Snaked for 2-Wire Resistance

TEST STEP	Flex Mode	Pendulum Mode
	GROUP 1	GROUP 2
	DV	DV
	GND, ±90° Bend Shroud	GND, ±35° Bend Shroud
01	Resistance	Resistance
02	5000 Cycles	5000 Cycles
03	Data Review	Data Review
04	Resistance	Resistance
05	10000 Cycles	10000 Cycles
06	Data Review	Data Review
07	Resistance	Resistance
08	15000 Cycles	15000 Cycles
09	Data Review	Data Review
10	Resistance	Resistance
11	20000 Cycles	20000 Cycles
12	Data Review	Data Review
13	Resistance	Resistance
14	25000 Cycles	25000 Cycles
15	Resistance	Resistance

Cycling with 8 oz. cable loading at 1500 to 3000 /Hour
 25 to 50 per minute

ATTRIBUTE DEFINITIONS

The following is a brief, simplified description of attributes.

THERMAL:

- 1) EIA-364-17, *Temperature Life with or without Electrical Load Test Procedure for Electrical Connectors*.
- 2) Test Condition 4 at 105° C.
- 3) Test Time Condition B for 250 hours.
- 4) Connectors are sometimes mated and all samples are pre-conditioned at ambient.

HUMIDITY:

- 1) Reference document: EIA-364-31, *Humidity Test Procedure for Electrical Connectors*.
- 2) Test Condition B, 240 Hours.
- 3) Method III, +25° C to + 65° C, 90% to 98% Relative Humidity excluding sub-cycles 7a and 7b.
- 4) Connectors are sometimes mated and all samples are pre-conditioned at ambient.

TEMPERATURE RISE (Current Carrying Capacity, CCC):

- 1) EIA-364-70, *Temperature Rise versus Current Test Procedure for Electrical Connectors and Sockets*.
- 2) When current passes through a contact, the temperature of the contact increases as a result of I^2R (resistive) heating.
- 3) The number of contacts being investigated plays a significant part in power dissipation and therefore temperature rise.
- 4) The size of the temperature probe can affect the measured temperature.
- 5) Copper traces on PC boards will contribute to temperature rise:
 - a. Self heating (resistive)
 - b. Reduction in heat sink capacity affecting the heated contacts
- 6) A de-rating curve, usually 20%, is calculated.
- 7) Calculated de-rated currents at three temperature points are reported:
 - a. Ambient
 - b. 55° C
 - c. 65° C
 - d. 70° C
- 8) Typically, neighboring contacts (in close proximity to maximize heat build up) are energized.
- 9) The thermocouple (or temperature measuring probe) will be positioned at a location to sense the maximum temperature in the vicinity of the heat generation area.
- 10) A computer program, *TR 803.exe*, ensures accurate stability for data acquisition.
- 11) Hook-up wire cross section is larger than the cross section of any connector leads/PC board traces, jumpers, etc.
- 12) Hook-up wire length is longer than the minimum specified in the referencing standard.

INSULATION RESISTANCE (IR):

To determine the resistance of insulation materials to leakage of current through or on the surface of these materials when a DC potential is applied.

- 1) PROCEDURE:
 - a. Reference document: EIA-364-21, *Insulation Resistance Test Procedure for Electrical Connectors*.
 - b. Test Conditions:
 - i. Between Adjacent Contacts
 - ii. Electrification Time 2.0 minutes
 - iii. Test Voltage (500 VDC) corresponds to calibration settings for measuring resistances.
- 2) MEASUREMENTS:
- 3) When the specified test voltage is applied (VDC), the insulation resistance shall not be less than 5000 megohms.

DIELECTRIC WITHSTANDING VOLTAGE (DWV):

To determine if the sockets can operate at its rated voltage and withstand momentary over potentials due to switching, surges, and other similar phenomenon. Separate samples are used to evaluate the effect of environmental stresses so not to influence the readings from arcing that occurs during the measurement process.

- 1) PROCEDURE:
 - a. Reference document: EIA-364-20, *Withstanding Voltage Test Procedure for Electrical Connectors*.
 - b. Test Conditions:
 - i. Between Adjacent Contacts
 - ii. Rate of Application 500 V/Sec
 - iii. Test Voltage (VAC) until breakdown occurs
- 2) MEASUREMENTS/CALCULATIONS
 - a. The breakdown voltage shall be measured and recorded.
 - b. The dielectric withstanding voltage shall be recorded as 75% of the minimum breakdown voltage.
 - c. The working voltage shall be recorded as one-third (1/3) of the dielectric withstanding voltage (one-fourth of the breakdown voltage).

SUPPLEMENTAL TESTS**CONNECTOR PULL:**

- 1) Secure cable near center and pull on connector
 - a. At 90°, right angle to cable
 - b. At 0°, in-line with cable

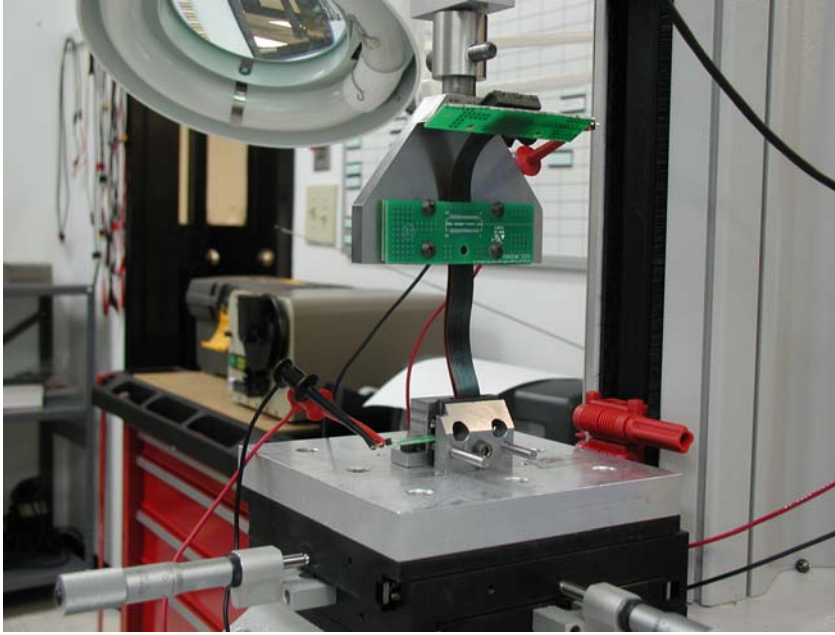

Fig. 1
(Typical set-up, actual part not depicted.)
0° Connector pull, notice the electrical continuity hook-up wires.

CABLE DURABILITY:

- 1) Oscillate and monitor electrical continuity for open circuit indication.
 - a. $\pm 35^\circ$ Pendulum Mode, bend up to 25,000 cycles with 8 oz. load on cable end.

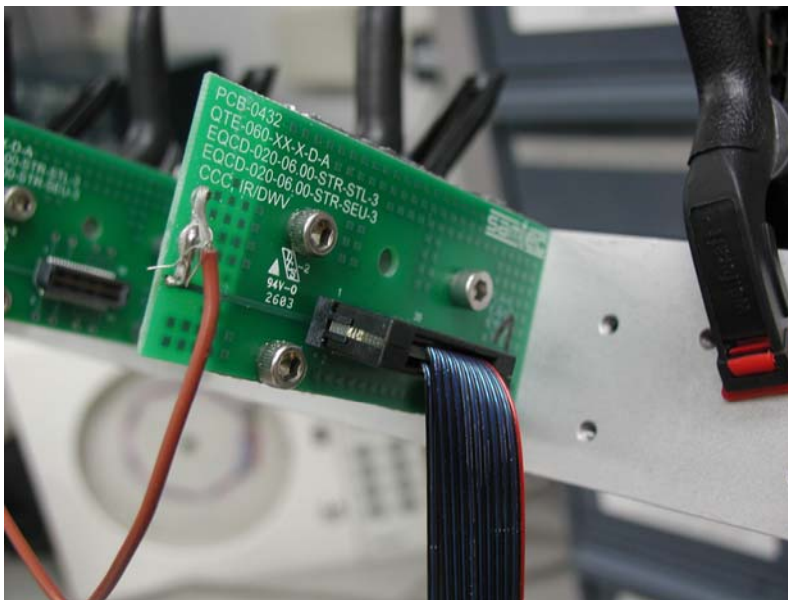

Fig. 2
(Typical set-up, actual part not depicted.)

- b. $\pm 90^\circ$ Flex Mode, bend up to 25,000 cycles with 8 oz. load on cable end.

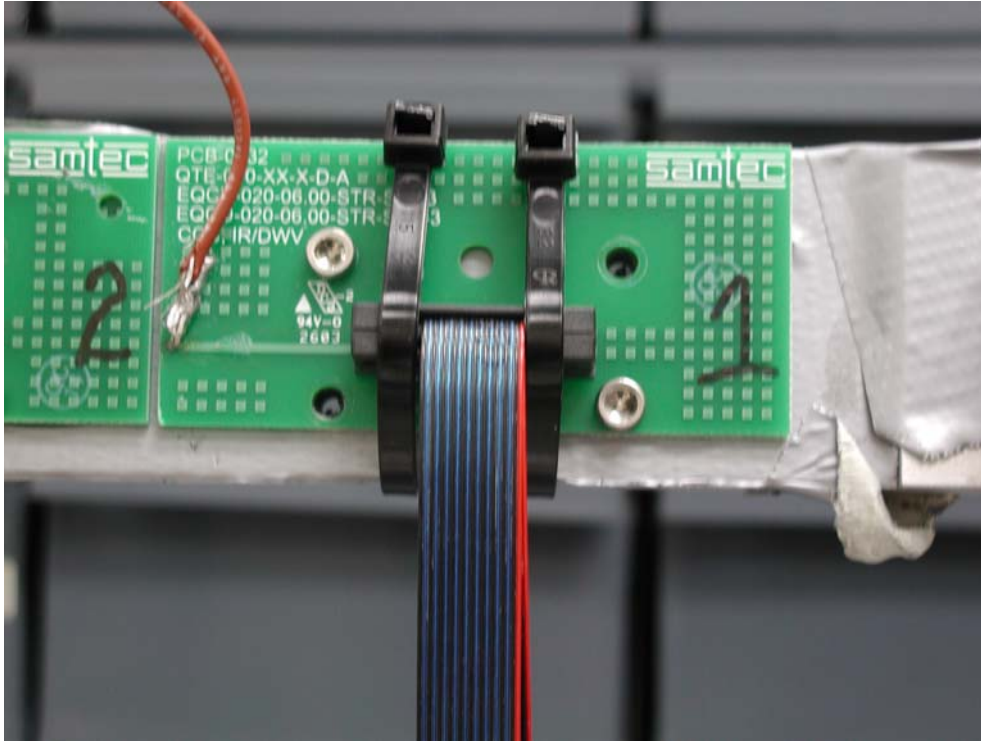

Fig. 3
(Typical set-up, actual part not depicted.)

RESULTS

Temperature Rise, CCC at a 20% de-rating

- CCC for a 30°C Temperature Rise (1 Cable)-----0.6 A per contact with 6 adjacent contacts powered
- CCC for a 30°C Temperature Rise (2 Cables) -----0.4 A per contact with 6 adjacent contacts powered

Insulation Resistance minimums, IR

- Initial
 - Top Cable-----50,000 Meg Ω ----- Pass
 - Bottom Cable -----100,000 Meg Ω
- Thermal
 - Top Cable-----100,000 Meg Ω
 - Bottom Cable -----100,000 Meg Ω
- Humidity
 - Top Cable-----50,000 Meg Ω
 - Bottom Cable -----100,000 Meg Ω

Dielectric Withstanding Voltage minimums, DWV

- Initial
 - Breakdown
 - Top Cable-----800 VAC
 - Bottom Cable-----1,020 VAC
 - DWV
 - Top Cable-----600 VAC
 - Unmated-----765 VAC
 - Working voltage
 - Top Cable-----200 VAC
 - Bottom Cable-----255 VAC
- Thermal
 - Breakdown
 - Top Cable-----1,020 VAC
 - Bottom Cable-----1,120 VAC
 - DWV
 - Top Cable-----765 VAC
 - Unmated-----840 VAC
 - Working voltage
 - Top Cable-----255 VAC
 - Bottom Cable-----280 VAC
- Humidity
 - Breakdown
 - Top Cable-----940 VAC
 - Bottom Cable-----840 VAC
 - DWV
 - Top Cable-----705 VAC
 - Bottom Cable-----630 VAC
 - Working voltage
 - Top Cable-----235 VAC
 - Bottom Cable-----210 VAC

SUPPLEMENTAL TESTING**Supplemental – Connector/Cable Pull**

- 0° ----- 99.18 lbs min
- 90° ----- 57.53 lbs min

Supplemental – Cable Bend 25,000 Cycles

- $\pm 35^{\circ}$ Pendulum Mode ----- No Electrical Failures
- $\pm 90^{\circ}$ Flex Mode ----- Minimum # of 3,746 Cycles to Failure.

DATA SUMMARIES

TEMPERATURE RISE (Current Carrying Capacity, CCC):

- 1) High quality thermocouples whose temperature slopes track one another were used for temperature monitoring.
- 2) The thermocouples were placed at a location to sense the maximum temperature generated during testing.
- 3) Temperature readings recorded are those for which three successive readings, 15 minutes apart, differ less than 1° C (computer controlled data acquisition).
- 4) Adjacent contacts were powered:
 - a. Linear configuration with SIX adjacent conductors/contacts powered

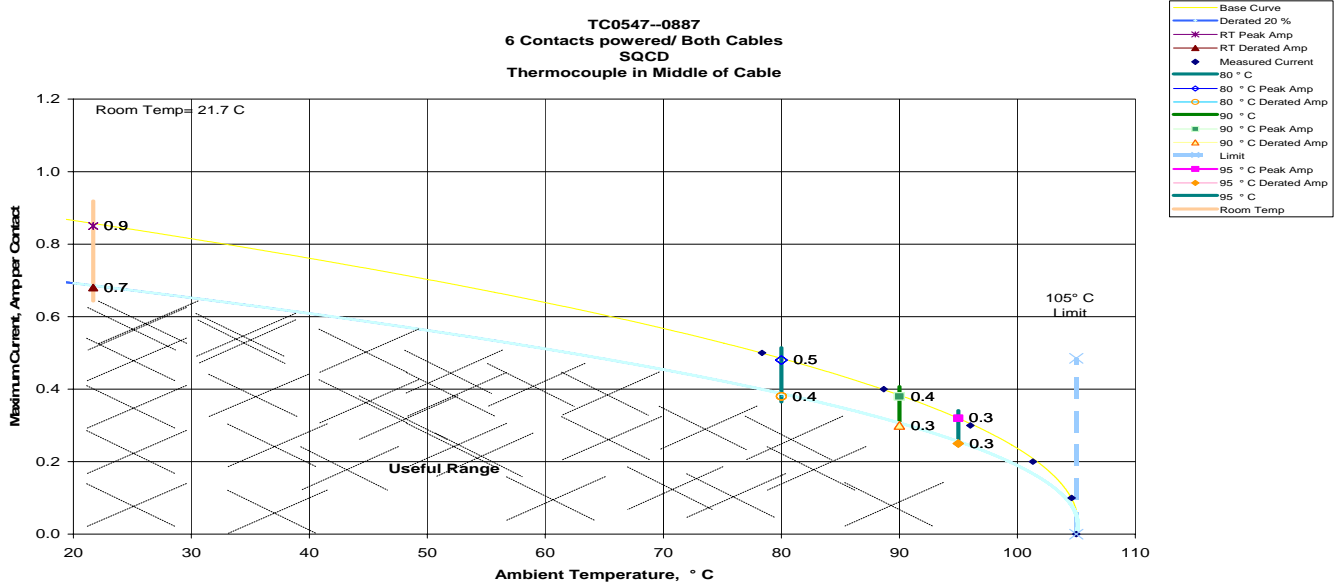
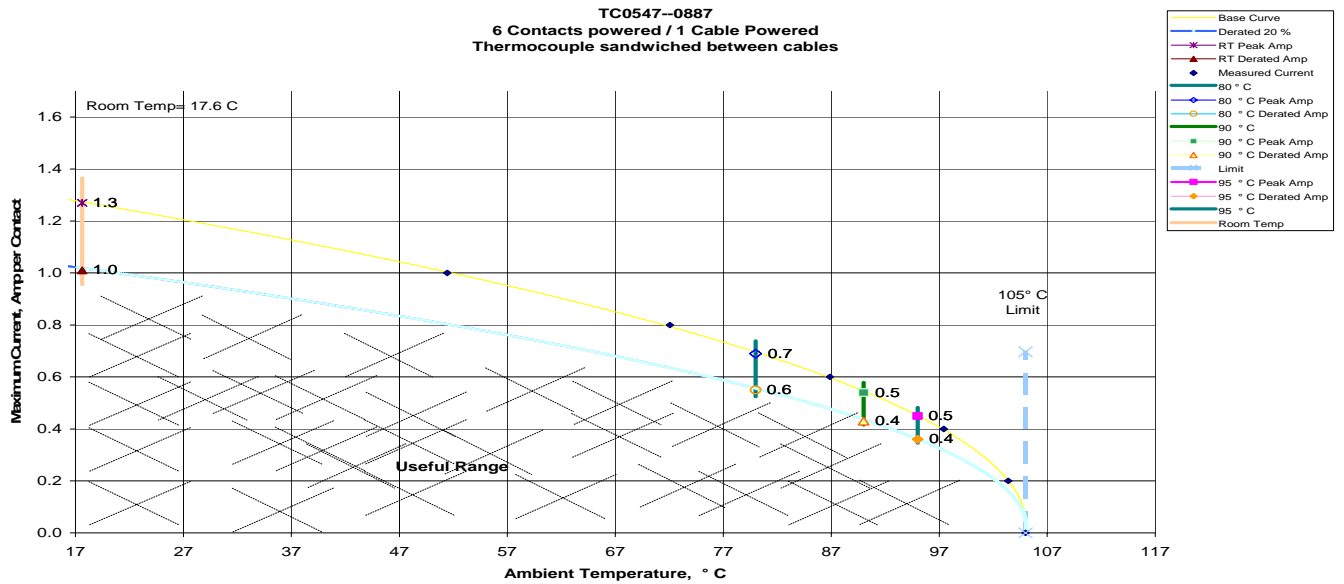

DATA SUMMARIES Continued**INSULATION RESISTANCE (IR):**

	Initial, Meg Ohms		Thermal, Meg Ohms		Humidity, Meg Ohms	
	Top	Bottom	Top	Bottom	Top	Bottom
	<u>Insulation Resistance</u>	<u>Insulation Resistance</u>	<u>Insulation Resistance</u>	<u>Insulation Resistance</u>	<u>Insulation Resistance</u>	<u>Insulation Resistance</u>
Average	50000	100000	100000	100000	75000	100000
Min	50000	100000	100000	100000	50000	100000
Max	50000	100000	100000	100000	100000	100000

DIELECTRIC WITHSTANDING VOLTAGE (DWV):

	Initial, VAC Top			Initial, VAC Bottom		
	<u>Breakdown Voltage</u>	<u>DWV</u>	<u>Working Voltage</u>	<u>Breakdown Voltage</u>	<u>DWV</u>	<u>Working Voltage</u>
	Average	880	660	220	1030	773
Min	800	600	200	1020	765	255
Max	960	720	240	1040	780	260

	Thermal, VAC Top			Thermal, VAC Bottom		
	<u>Breakdown Voltage</u>	<u>DWV</u>	<u>Working Voltage</u>	<u>Breakdown Voltage</u>	<u>DWV</u>	<u>Working Voltage</u>
	Average	1070	803	268	1120	840
Min	1020	765	255	1120	840	280
Max	1120	840	280	1120	840	280

	Humidity, VAC Top			Humidity, VAC Bottom		
	<u>Breakdown Voltage</u>	<u>DWV</u>	<u>Working Voltage</u>	<u>Breakdown Voltage</u>	<u>DWV</u>	<u>Working Voltage</u>
	Average	960	720	240	930	698
Min	940	705	235	840	630	210
Max	980	735	245	1020	765	255

DATA SUMMARIES Continued**SUPPLEMENTAL – CONNECTOR/CABLE PULL**

	0 Deg. Pull	90 Deg. Pull
	<u>Force (Lbs)</u>	<u>Force (Lbs)</u>
Minimum	99.18	57.53
Maximum	164.99	78.44
Average	147.5	69.2

SUPPLEMENTAL – CABLE BEND 25,000 CYCLES**A. 35 Deg. Pendulum**

	Initial	5000Cycles	10000 Cycles	15000 Cycles	20000 Cycles	25000 Cycles
Avg	20.1080	20.0480	20.0100	20.0640	20.0620	20.1120
Min	20.0500	19.9800	19.9300	19.9800	19.9900	20.0400
Max	20.1800	20.1300	20.0900	20.1300	20.1300	20.1800
St. Dev.	0.0545	0.0630	0.0711	0.0627	0.0540	0.0630
Count	5	5	5	5	5	5

B. 90 Deg. Flex

	Initial	5000Cycles	10000 Cycles	15000 Cycles	20000 Cycles	25000 Cycles
Avg	30.4383	25.0100	20.5950	24.1150	20.8400	#DIV/0!
Min	20.1000	20.3500	20.4800	20.6100	20.8400	0.0000
Max	80.9300	36.6100	20.7100	27.6200	20.8400	0.0000
St. Dev.	24.7371	7.7772	0.1626	4.9568	#DIV/0!	#DIV/0!
Count	6	4	2	2	1	0

DATA**INSULATION RESISTANCE (IR):**

<u>Sample #</u>	<u>Initial, Meg Ohms</u>		<u>Thermal, Meg Ohms</u>		<u>Humidity, Meg Ohms</u>	
	<u>Top</u>	<u>Bottom</u>	<u>Top</u>	<u>Bottom</u>	<u>Top</u>	<u>Bottom</u>
	<u>Insulation Resistance</u>	<u>Insulation Resistance</u>	<u>Insulation Resistance</u>	<u>Insulation Resistance</u>	<u>Insulation Resistance</u>	<u>Insulation Resistance</u>
1	50000	100000	100000	100000	100000	100000
2	50000	100000	100000	100000	50000	100000

DIELECTRIC WITHSTANDING VOLTAGE (DWV):

<u>Sample #</u>	<u>Initial, VAC Top</u>			<u>Initial, VAC Bottom</u>		
	<u>Breakdown Voltage</u>	<u>DWV</u>	<u>Working Voltage</u>	<u>Breakdown Voltage</u>	<u>DWV</u>	<u>Working Voltage</u>
1	800	600	200	1020	765	255
2	960	720	240	1040	780	260

<u>Sample #</u>	<u>Thermal, VAC Top</u>			<u>Thermal, VAC Bottom</u>		
	<u>Breakdown Voltage</u>	<u>DWV</u>	<u>Working Voltage</u>	<u>Breakdown Voltage</u>	<u>DWV</u>	<u>Working Voltage</u>
1	1120	840	280	1120	840	280
2	1020	765	255	1120	840	280

<u>Sample #</u>	<u>Humidity, VAC Top</u>			<u>Humidity, VAC Bottom</u>		
	<u>Breakdown Voltage</u>	<u>DWV</u>	<u>Working Voltage</u>	<u>Breakdown Voltage</u>	<u>DWV</u>	<u>Working Voltage</u>
1	940	705	235	840	630	210
2	980	735	245	1020	765	255

SUPPLEMENTAL – CONNECTOR/CABLE PULL

<u>Sample#</u>	<u>0 Deg. Pull</u>	<u>90 Deg. Pull</u>
	<u>Maximum Force (Lbs)</u>	<u>Maximum Force (Lbs)</u>
1	164.99	74.17
2	158.30	78.44
3	156.24	75.93
4	158.58	57.53
5	99.18	60.12

DATA (Continued)**SUPPLEMENTAL – CABLE BEND 25,000 CYCLES****A. 35 Deg. Pendulum**

Cable	Resistance, Ohms					
	Initial	5000Cycles	10000 Cycles	15000 Cycles	20000 Cycles	25000 Cycles
1	20.05	19.98	19.93	20.02	20.03	20.06
2	20.18	20.13	20.09	20.13	20.13	20.18
3	20.14	20.08	20.05	20.11	20.09	20.17
4	20.11	19.99	19.94	19.98	19.99	20.04
5	20.06	20.06	20.04	20.08	20.07	20.11

B. 90 Deg. Flex

Cable	Resistance, Ohms					
	Initial	5000Cycles	10000 Cycles	15000 Cycles	20000 Cycles	25000 Cycles
1	20.10	20.80	Failed @ 7329 Cycles	N/A	N/A	N/A
2	20.24	36.61	Failed @ 7590 Cycles	N/A	N/A	N/A
3	20.29	20.35	20.71	27.62	20.84	Failed @ 22448 Cycles
4	20.23	22.28	20.48	20.61	Failed @ 18372 Cycles	
5	20.84	Failed @ 3746 Cycles	N/A	N/A	N/A	N/A

EQUIPMENT AND CALIBRATION SCHEDULES**Equipment #:** THL-02**Description:** Temperature/Humidity Chart Recorder**Manufacturer:** Dickson**Model:** THDX**Serial #:** 00120351**Accuracy:** Temp: +/- 1C; Humidity: +/-2% RH (0 - 60%) +/- 3% RH (61 - 95%).

... Last Cal: 06/16/06, Next Cal: 06/16/07

Equipment #: MO-02**Description:** Multimeter /Data Acquisition System**Manufacturer:** Keithley**Model:** 2700**Serial #:** 0780546**Accuracy:** See Manual

... Last Cal: 05/12/06, Next Cal: 05/12/07

Equipment #: MO-04**Description:** Multimeter /Data Acquisition System**Manufacturer:** Keithley**Model:** 2700**Serial #:** 0798688**Accuracy:** See Manual

... Last Cal: 01/31/06, Next Cal: 01/31/07

Equipment #: PS-01**Description:** System Power Supply**Manufacturer:** Hewlett Packard**Model:** HP 6033A**Serial #:** (HP) 3329A-07330**Accuracy:** See Manual

... Last Cal: 05/12/06, Next Cal: 05/12/07

Equipment #: TC090601-103/105**Description:** IC Thermocouple-103/105**Manufacturer:** Samtec**Model:****Serial #:** TC090601-103/105**Accuracy:** +/- 1 degree C

... Last Cal: , Next Cal:

Equipment #: HPM-01**Description:** Hipot Megommeter**Manufacturer:** Hipotronics**Model:** H306B-A**Serial #:** M9905004**Accuracy:** 2 % Full Scale Accuracy

... Last Cal: 5/12/06, Next Cal: 05/12/07

Equipment #: OV-03**Description:** Cascade Tek Forced Air Oven**Manufacturer:** Cascade Tek**Model:** TFO-5**Serial #:** 0500100**Accuracy:** Temp. Stability: +/- .1C/C change in ambient Temp. Stability: +/- .1C/C change in ambient
... Last Cal: 05/12/06, Next Cal: 05/12/07**Equipment #:** THC-01**Description:** Temperature/Humidity Chamber**Manufacturer:** Thermotron**Model:** SM-8-7800**Serial #:** 30676**Accuracy:** See Manual

... Last Cal: 8/18/2006, Next Cal: 8/18/2007

Equipment #: TCT-03**Description:** Dillon Quantrol TC2 Test Stand**Manufacturer:** Dillon Quantrol**Model:** TC2**Serial #:** 02-1033-03**Accuracy:** Speed Accuracy: +/- 5% of indicated speed; Displacement: +/- 5 micrometers.
... Last Cal: 5/12/06, Next Cal: 5/12/07**Equipment #:** LC-2500N(icell)**Description:** 2500 N Load Cell for Dillon Quantrol**Manufacturer:** Dillon Quantrol**Model:** icell**Serial #:** 01-0132-01**Accuracy:** .10% of capacity

... Last Cal: 6/13/06, Next Cal: 6/13/07

Equipment #: HDR - 01**Description:** HDR Flex Tester**Manufacturer:** Samtec Inc.**Model:** AT-1440-000**Serial #:** 00120351**Accuracy:** N/A

... Last Cal: No Calibration Required, Next Cal:

...