

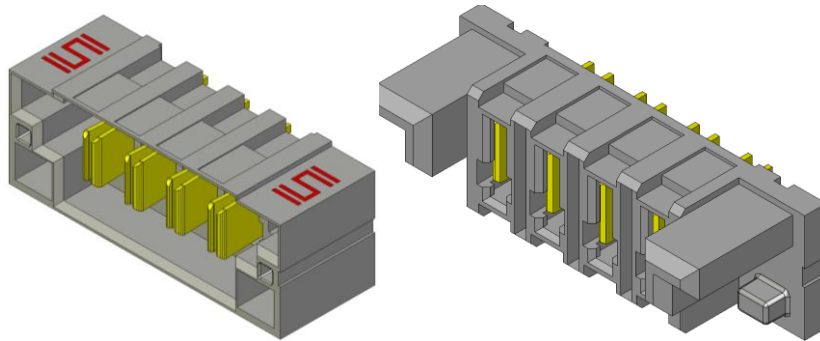

Project Number:		Tracking Code: TC0745-1489_REV3				
Requested by: Joel Keinath		Date: 01/10/2008		Product Rev:		
Part #: MPS-08-7.70-01-T-V/MPT-08-6.30-T-V			Lot #:		Tech:	Eng: Joel Keinath
Part description: Mini Power Strip System					Qty to test: 20	
Test Start: 12/04/2007		Test Completed: 01/02/2008				

SAMTEC POWER CHARACTERIZATION



PART DESCRIPTION

MINI POWER STRIP SYSTEM

MPS-08-7.70-01-T-V/MPT-08-6.30-01-T-V

CERTIFICATION

All instruments and measuring equipment were calibrated to National Institute for Standards and Technology (NIST) traceable standards according to ISO 10012-1 and ANSI/NCSL 2540-1, as applicable.

All contents contained herein are the property of Samtec. No portion of this report, in part or in full shall be reproduced without prior written approval of Samtec.

SCOPE

1. Temperature Rise/Current Carrying Capacity
 - 1.1. To determine the amount of current the device under test (DUT) can safely carry over the operating temperature range of the DUT.
 - 1.2. Contact loading will also be addressed in this document which will determine how much current can be carried as the number of energized contacts is varied.
2. Current Cycling
 - 2.1. To determine the performance of the device under test (DUT) when subjected to the power-on/power-off cycling that heats and cools the DUT in normal everyday use.
 - 2.2. Contact loading will set to 100% throughout the test.

APPLICABLE DOCUMENTS

Standards: EIA Publication 364-70 Temperature Rise
EIA Publication 364-06 Contact Resistance
EIA Publication 364-55 Current Cycling
TLPM-032 Current Carrying Capacity
TLPM-084 Current Cycling
IEC 512-3 Electromechanical Components for Electronic Equipment: Basic Testing Procedures and Measuring Methods, Part 3: Current Carrying Capacity Tests

TEST SAMPLES AND PREPARATION

1. All materials shall be manufactured in accordance with the applicable product specification.
2. All test samples shall be identified and encoded to maintain traceability throughout the test sequences.
3. After soldering, the parts to be used shall be cleaned according to TLWI-0001.
4. All samples shall be visually inspected and cleaned as necessary.
5. Any additional preparation shall be noted in the individual test sequences.
6. Solder Information: Lead Free
7. Re-Flow Time/Temp: See accompanying profile.
8. All products designed to operate mounted on a printed circuits board shall be tested mounted to test boards in accordance with EIA-364-70.

PREPARED TEST SAMPLE

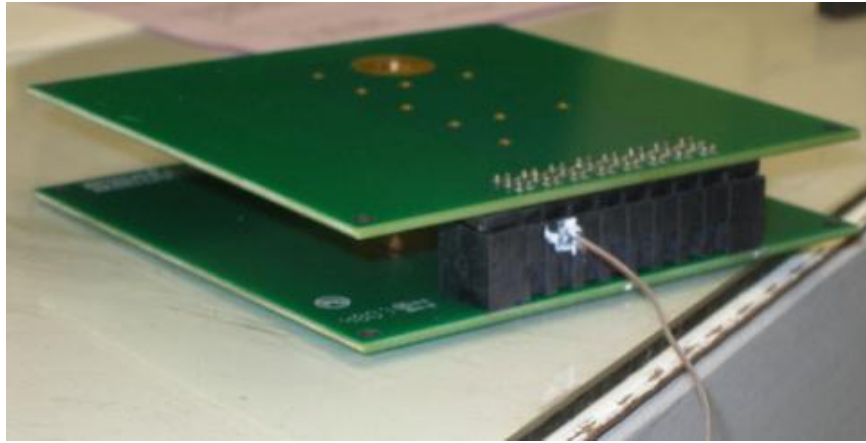

9. The following loading configurations shall be tested for Temperature Rise/Current Carrying Capacity testing of single row connector systems:
- 9.1. One contact energized only
 - 9.2. Two contacts energized adjacent to each other
 - 9.3. Three contacts energized adjacent to each other
 - 9.4. Four contacts energized adjacent to each other
 - 9.5. All contacts energized

Test Condition as in 9.1 above

✦ Indicates energized contacts

✦ Indicates thermocouple monitored, energized contacts

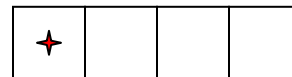

10. The following loading configurations shall be tested for Temperature Rise/Current Carrying Capacity testing of two row connector systems:
- 10.1. Two by One contact energized
 - 10.2. Two by Two contacts energized adjacent to each other
 - 10.3. Two by Three contacts energized adjacent to each other
 - 10.4. Two by Four contacts energized adjacent to each other
 - 10.5. All contacts energized

Test Condition as in 10.1 above

✦ Indicates energized contacts

✦ Indicates thermocouple monitored, energized contacts

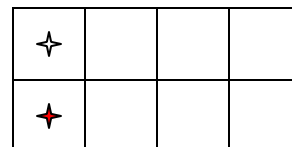

11. For Current Cycling, only 100 % loading will be tested.

OVEN PROFILE (Soldering Parts to Test Boards)

**Standard Solder Paste Reflow Profile
for Kester Paste Containing
Alloys: Sn63Pb37 or Sn62Pb36Ag02**

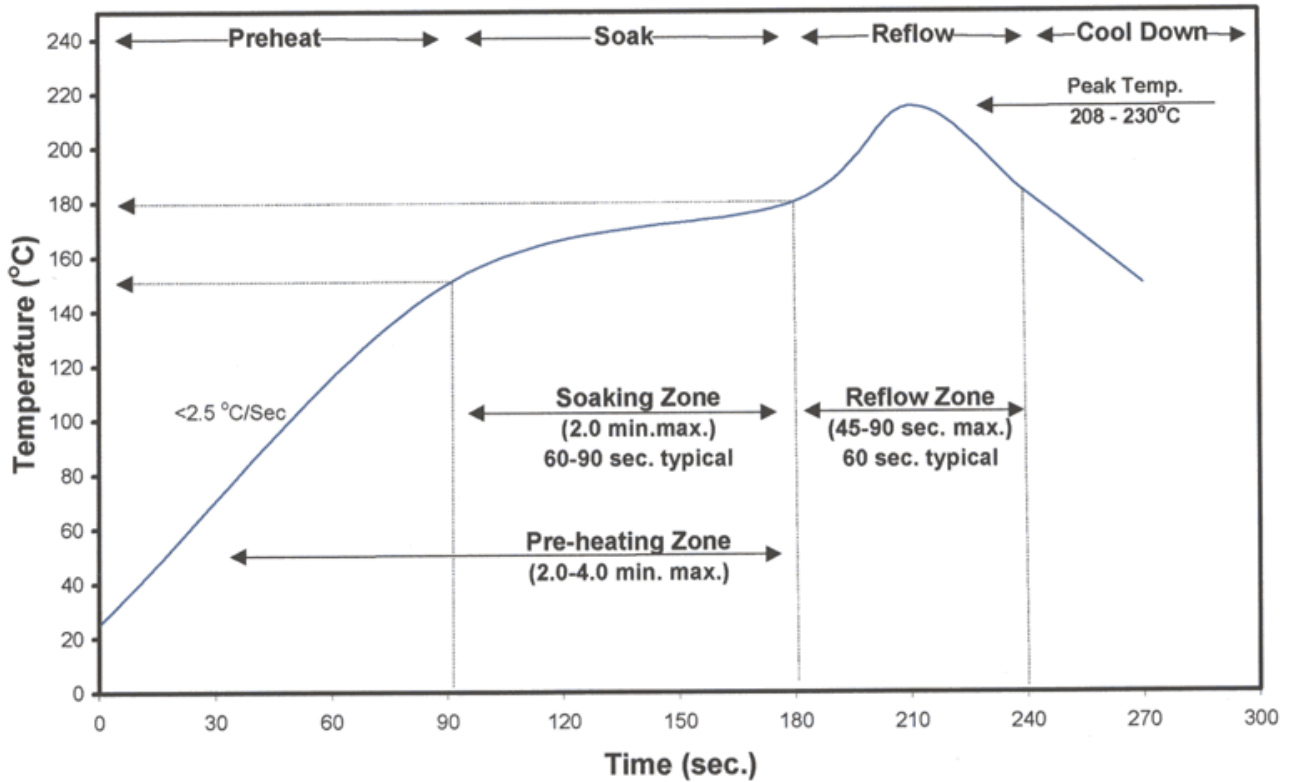

FLOWCHARTS

Current Carrying Capacity

3 Mated Assemblies Each

TEST STEP	GROUP A 3 Mated Assemblies 1 CONTACT POWERED	GROUP B 3 Mated Assemblies 2 CONTACTS POWERED	GROUP C 3 Mated Assemblies 3 CONTACTS POWERED	GROUP D 3 Mated Assemblies 4 CONTACTS POWERED	GROUP E 3 Mated Assemblies ALL CONTACTS POWERED
01	CCC	CCC	CCC	CCC	CCC

(TIN PLATING) - Tabulate calculated current at RT, 65° C, 75° C and 95° C
after derating 20% and based on 105° C

(GOLD PLATING) - Tabulate calculated current at RT, 85° C, 95° C and 115° C
after derating 20% and based on 125° C

CCC, Temp rise = EIA-364-70

Current Cycling

8 Mated Assemblies Each

TEST STEP	GROUP A 8 Mated Assemblies ALL CONTACTS POWERED
01	Current Cycle, 500 cycles at 125% of Rated current

Current Cycle = EIA 364-55, Condition "B", Method #4

Test at Current 125% of Rated Current

Measure at 30 minutes into 45 minute cycle

Measure Voltage Drop on 5 random contacts

<u>MPS-08-7.70-01-T-V/</u> <u>MPT-08-6.30-T-V</u>	POWER INTEGRITY TEST REPORT	TC0745--1489
		Revision 4

TEST PROCEDURES

Part No.	MPS-08-7.70-01-T-V	Mating Part No.	MPT-08-6.30-T-V
Sample Size	15	Technician	Troy Cook
Start Date	12/4/2007	Complete Date	12/4/2007
Room Ambient °C	26	Relative Humidity	35
Equipment ID#: MO-04, PS-07, TC111307-(001-017)			

TEMPERATURE RISE (Current Carrying Capacity, CCC):

12. Thermocouples shall be calibrated in accordance with Samtec documents; TLWI 0003, Thermocouple Welding Procedure and TLWI 0005, Thermocouple Calibration
13. The thermocouples shall be placed at a location to sense the maximum temperature generated during testing.
14. Temperature stability shall be defined as the temperature at which three successive readings, 5 minutes apart, differ less than 1° C (computer controlled data acquisition). This is the Temperature Rise that the Current Carrying Capacity and De-rating curves are based on.
15. The following loading configurations shall be tested (double for two row systems):
 - 15.1. One contact energized only
 - 15.2. Two contacts energized adjacent to each other
 - 15.3. Three contacts energized adjacent to each other
 - 15.4. Four contacts energized adjacent to each other
 - 15.5. All contacts energized
16. The following loading configurations shall be tested for Temperature Rise/Current Carrying Capacity testing of two row connector systems:
 - 16.1. Two by One contact energized
 - 16.2. Two by Two contacts energized adjacent to each other
 - 16.3. Two by Three contacts energized adjacent to each other
 - 16.4. Two by Four contacts energized adjacent to each other
 - 16.5. All contacts energized
17. Three samples shall be tested for each of the above configurations for a total of eighteen assemblies.
18. Temperature Rise measurements shall be made at 5 different current levels yielding temperature rises in the 10 to 70°C range.
19. The base curve for the Current Rating chart will be derived from the average (maximum) value of three test specimens in accordance with IEC 512-3, Test 5b.

<u>MPS-08-7.70-01-T-V/</u> <u>MPT-08-6.30-T-V</u>	POWER INTEGRITY TEST REPORT	TC0745--1489
		Revision 4

Part No.	MPS-08-7.70-01-T-V	Mating Part No.	MPT-08-6.30-T-V
Sample Size	8	Technician	Troy Cook
Start Date	12/7/2007	Complete Date	12/28/2007
Room Ambient °C	28.5	Relative Humidity	35
Equipment ID#: MO-09, PS-05, 126-133, TC111307-(126-133)			

CURRENT CYCLING

1. Samples shall be prepared and tested as above (paragraph 14.5).
2. Current Cycling shall be performed in accordance with EIA-364-55a, Test Condition
3. Testing shall be as follows:
 - 3.1. Test Current: 24.8 (125% of 30°C Rating)
 - 3.2. "ON" Time: 45 Minutes
 - 3.3. "OFF" Time: 15 Minutes
 - 3.4. Number of Cycles: 500
 - 3.5. Measurements: 40 minutes into ON cycle
 - 3.5.1. Temperature
 - 3.5.2. Voltage Drop/Contact Resistance
4. Temperature vs. Number of Cycles and Voltage Drop vs. Number of Cycles shall be measured and recorded.

TEST RESULTS

CURRENT CARRYING CAPACITY (CCC) RESULTS

- There was no evidence of physical damage to the test samples as tested.
- The following is a summary of the observed data:

Temperature Rise, CCC at a 20% de-rating

- CCC for a 30°C Temperature Rise----- 28.8A per contact with 1 contact powered
- CCC for a 30°C Temperature Rise----- 24.7A per contact with 2 contacts powered
- CCC for a 30°C Temperature Rise----- 24.1A per contact with 3 contacts powered
- CCC for a 30°C Temperature Rise----- 22.3A per contact with 4 contacts powered
- CCC for a 30°C Temperature Rise----- 18.5A per contact with 8 contacts powered

CURRENT CYCLING RESULTS

Test Condition: 500 Cycles, 45 minutes ON and 15 minutes OFF

- Test Current ----- 24.8 Amps
- Contact Resistances, Measured 40 minutes into the FIRST and LAST ON cycle
 - Initial
 - Min----- 0.15 mOhms
 - Max ----- 0.27 mOhms
 - Final
 - Min----- 0.15 mOhms
 - Max ----- 0.28 mOhms
- Temperature Change, Measured 40 minutes into the FIRST and LAST ON cycle
 - Initial Temperature Change----- 27.2 °C
 - Final Temperature Change ----- 28.3 °C

TEST DATA

CONTACT RESISTANCE @ RATED CURRENT

The following data represents the Voltage drop and Contact Resistance at Rated Current for the **100% ENERGIZED SAMPLES**:

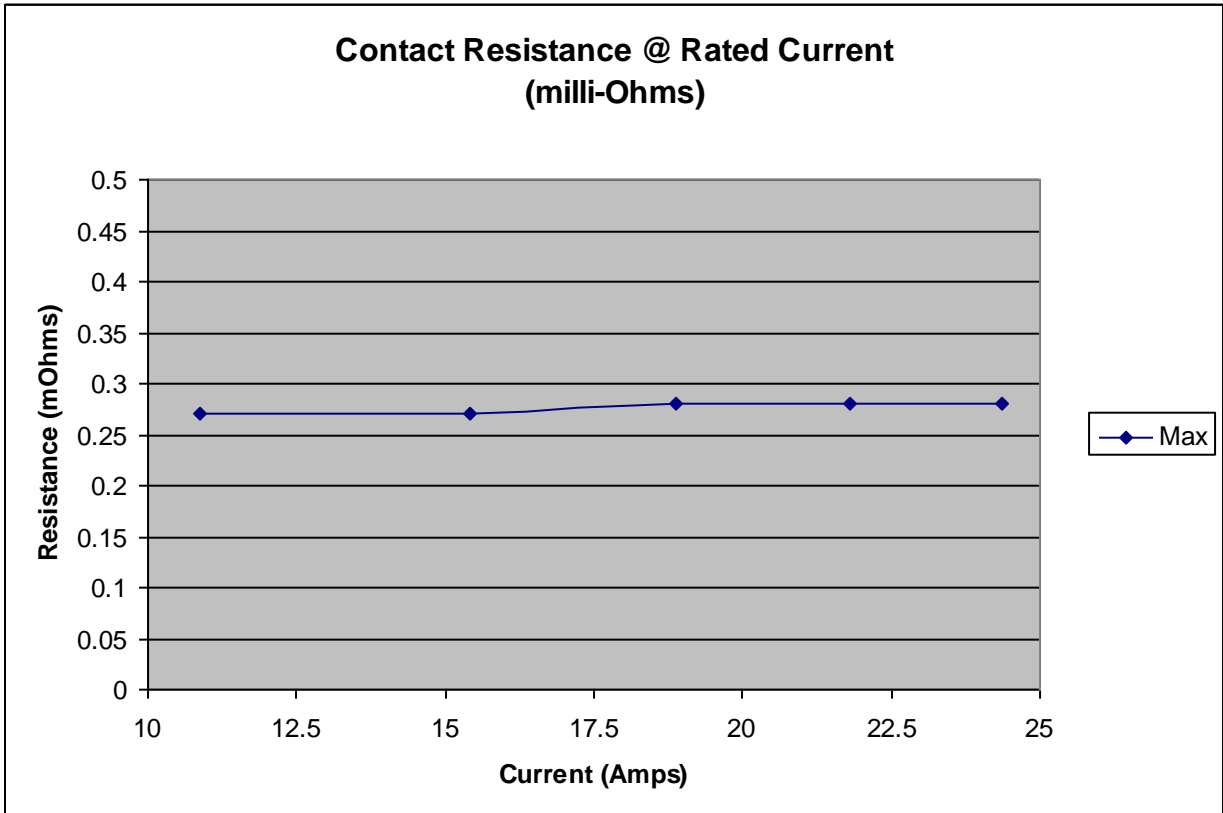

**CONTACT RESISTANCE DATA
ALL CONTACTS ENERGIZED
(mΩ)**

TEST CURRENT AMPS	10.89	15.4	18.87	21.79	24.36
Min	0.15	0.15	0.15	0.15	0.15
Max	0.27	0.27	0.28	0.28	0.28
Avg	0.21	0.21	0.21	0.22	0.22

TEST DATA

VOLTAGE DROP @ RATED CURRENT

The following data represents the Voltage drop at Rated Current for the **100% ENGERGIZED SAMPLES**:

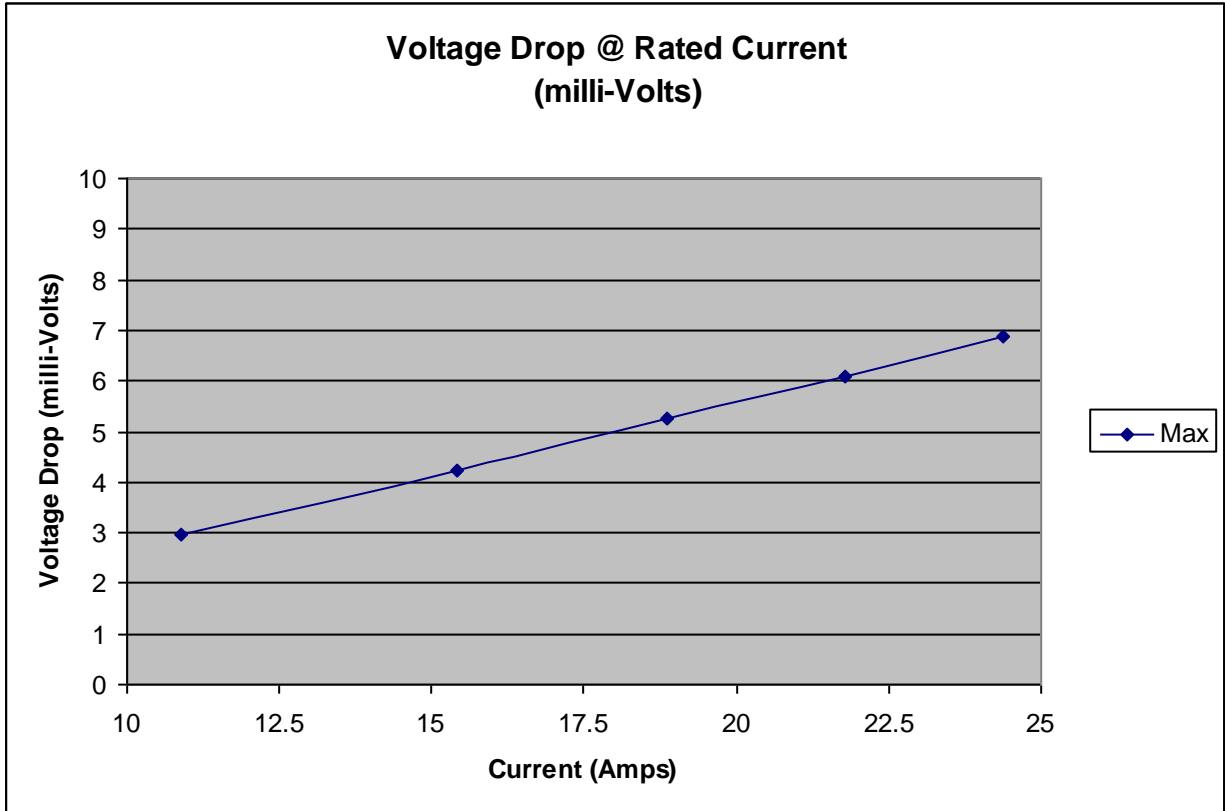

**VOLTAGE DROP DATA
ALL CONTACTS ENERGIZED
(mV)**

TEST CURRENT AMPS	10.89	15.4	18.87	21.79	24.36
Min	1.59	2.27	2.83	3.3	3.75
Max	2.96	4.23	5.24	6.1	6.88
Avg	2.26	3.23	4.02	4.7	5.32

CURRENT CARRYING CAPACITY DATA

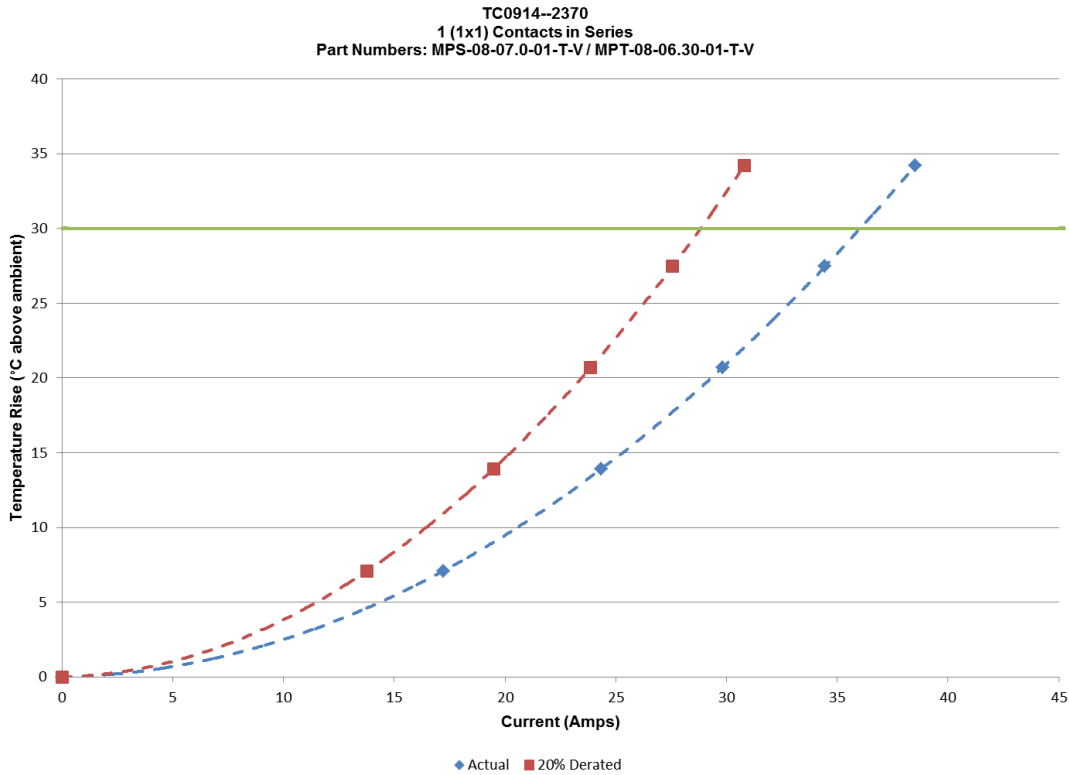
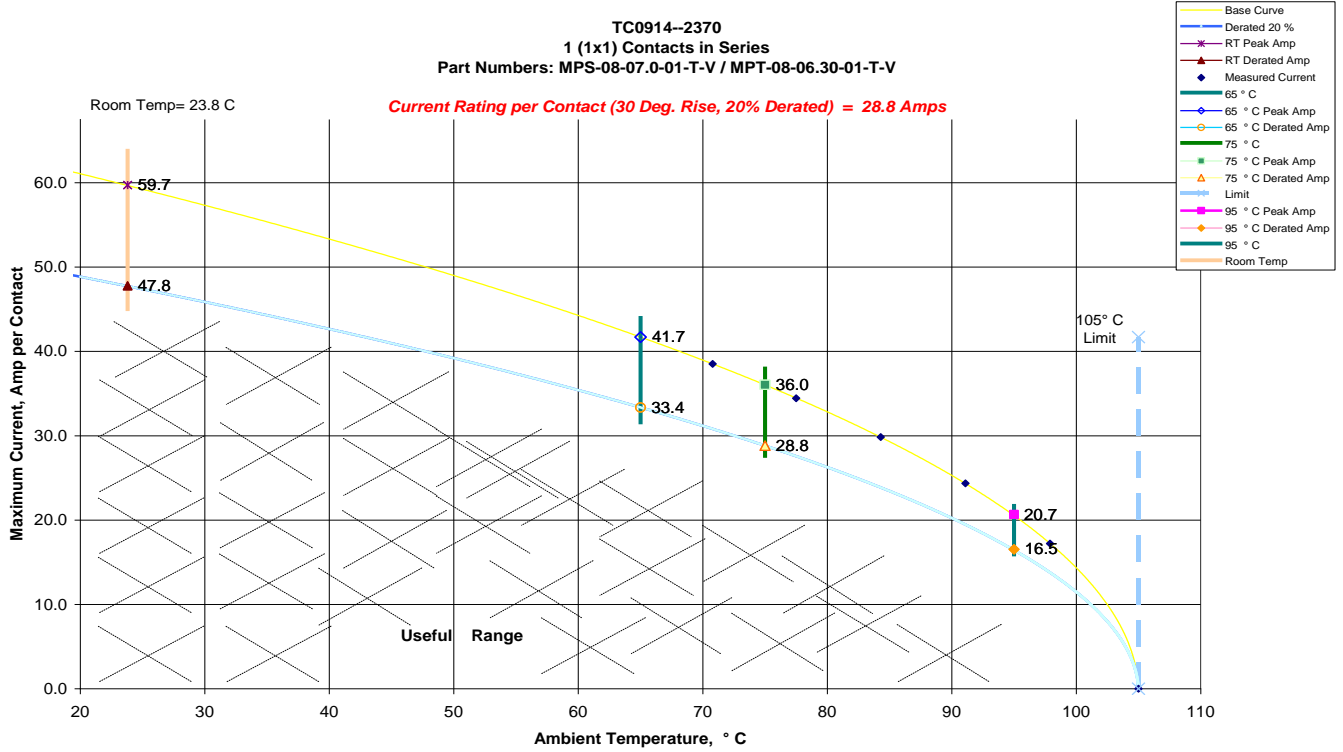

**TEMPERATURE RISE DATA
ONE CONTACT ENERGIZED
(Degrees Celsius above ambient)**

TEST CURRENT AMPS	17.21	24.34	29.83	34.45	38.51
Sample 1	6.7	13.1	19.5	25.9	32.3
Sample 2	7.1	14	20.7	27.4	34.2
Sample 3	7.5	14.7	21.9	29.1	36.2
Min	6.7	13.1	19.5	25.9	32.3
Max	7.5	14.7	21.9	29.1	36.2
Avg	7.1	13.93	20.7	27.47	34.23

Single Row
Configuration

✦ Indicates energized contacts

✦ Indicates thermocouple monitored, energized contacts



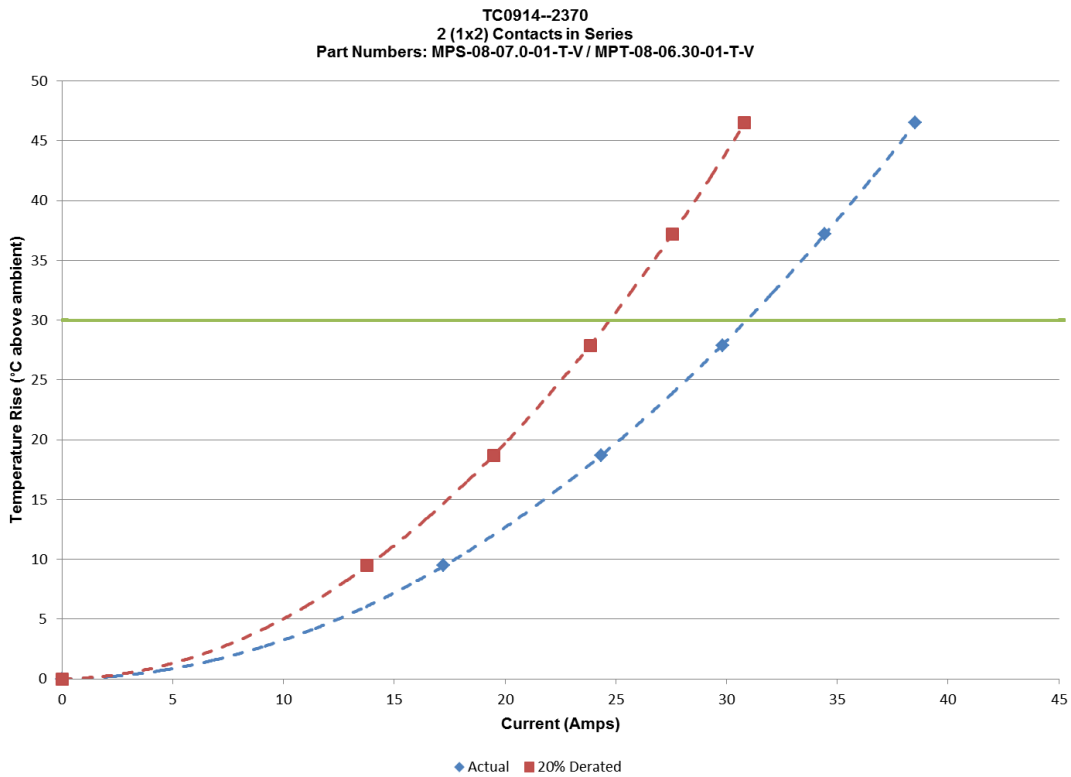
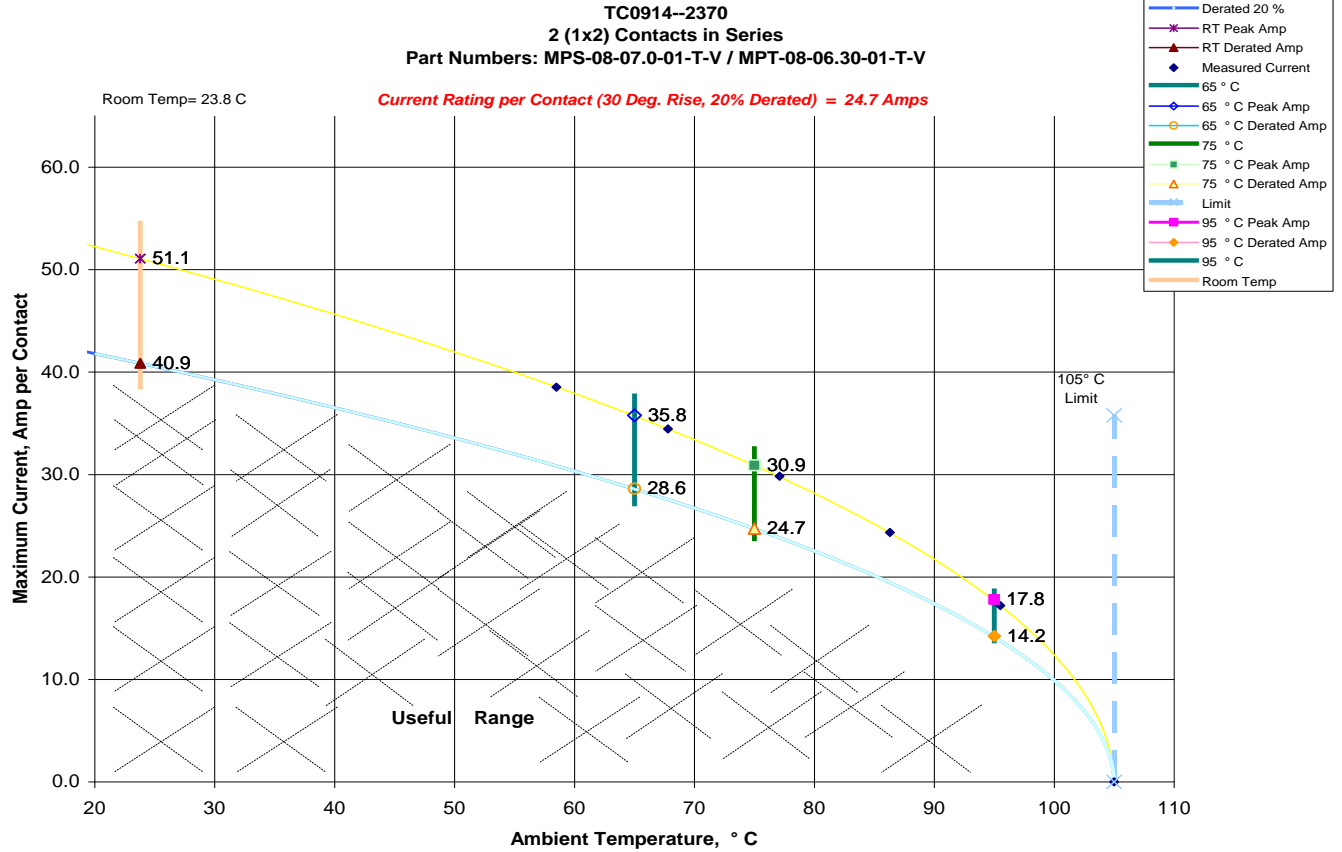

**TEMPERATURE RISE DATA
TWO CONTACTS ENERGIZED
(Degrees Celsius above ambient)**

TEST CURRENT AMPS	17.21	24.34	29.83	34.45	38.51
Sample 4	10	19.8	29.6	39.5	49.4
Sample 5	9.6	19	28.2	37.6	47.1
Sample 6	9	17.4	25.9	34.4	43
Min	9	17.4	25.9	34.4	43
Max	10	19.8	29.6	39.5	49.4
Avg	9.53	18.73	27.9	37.17	46.5

✦ Indicates energized contacts

✦ Indicates thermocouple monitored, energized contacts

✦	✦		
---	---	--	--

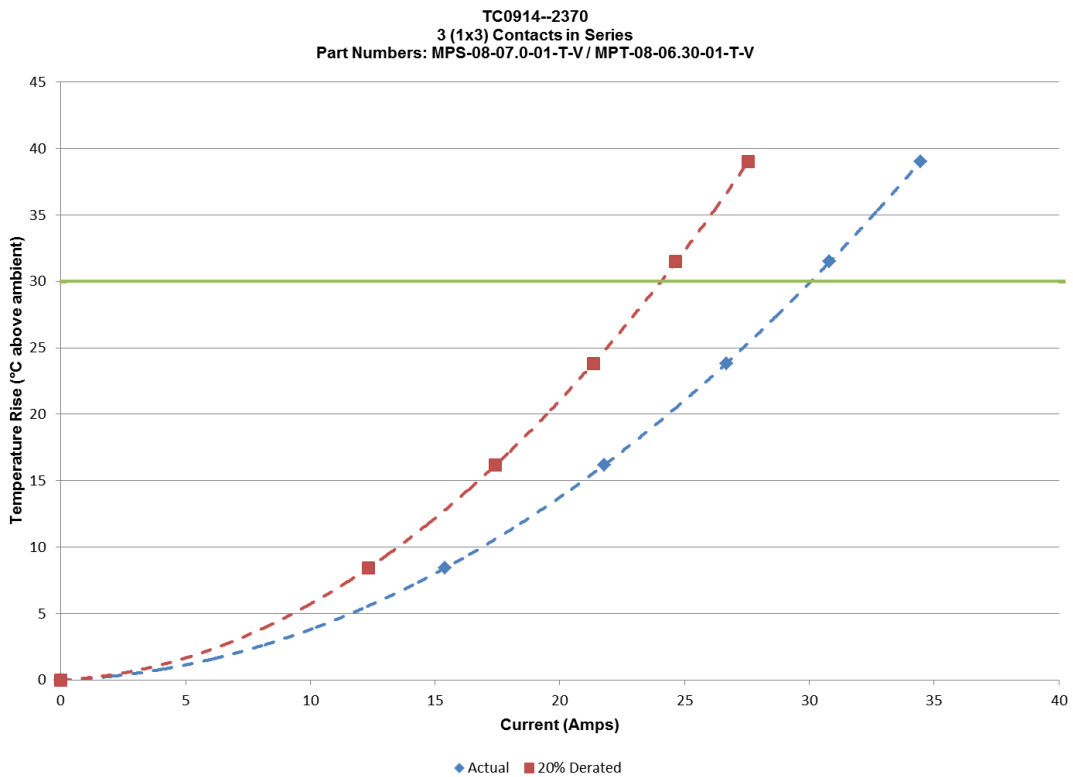
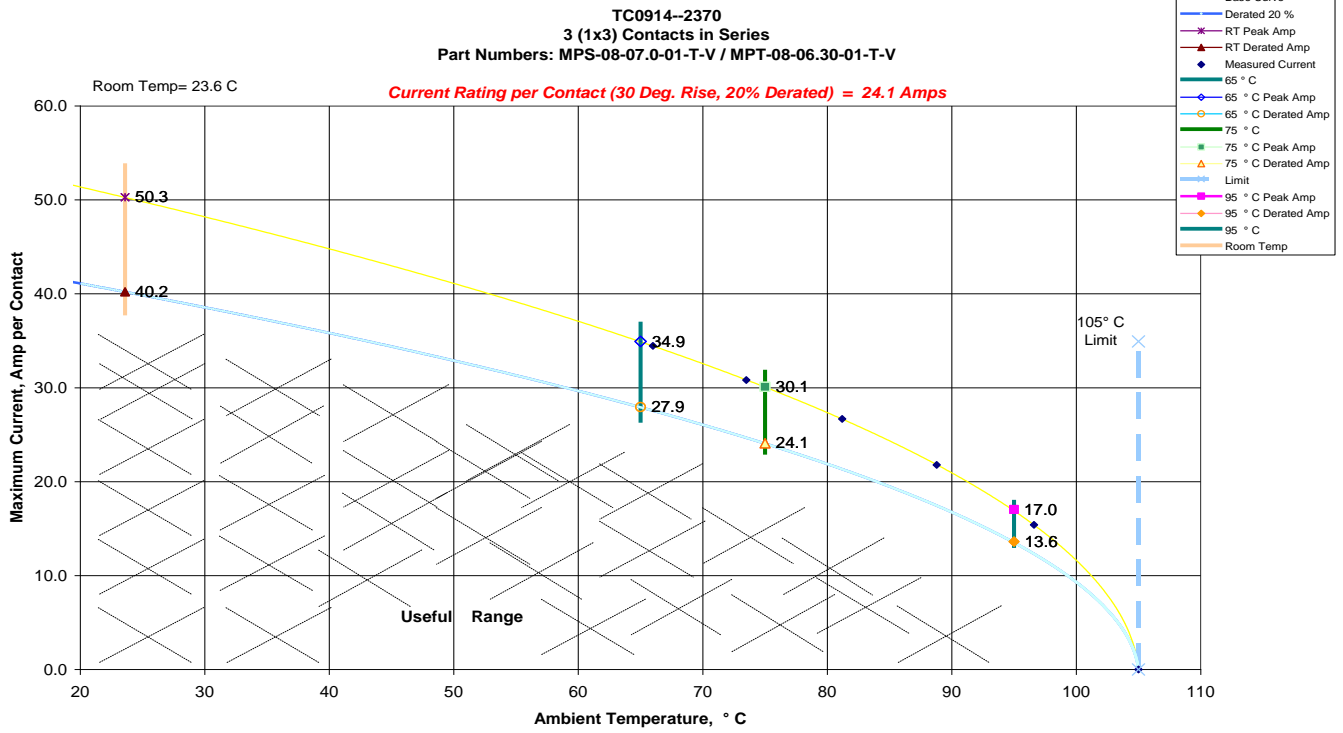

**TEMPERATURE RISE DATA
THREE CONTACTS ENERGIZED
(Degrees Celsius above ambient)**

TEST CURRENT AMPS	15.4	21.77	26.68	30.81	34.45
Sample 7	7.7	14.7	21.6	28.4	35.1
Sample 8	8.5	16.5	24.2	31.9	39.5
Sample 9	9	17.4	25.7	34.1	42.5
Min	7.7	14.7	21.6	28.4	35.1
Max	9	17.4	25.7	34.1	42.5
Avg	8.4	16.2	23.83	31.47	39.03

✦ Indicates energized contacts

✦ Indicates thermocouple monitored, energized contacts

✦	✦	✦	
---	---	---	--

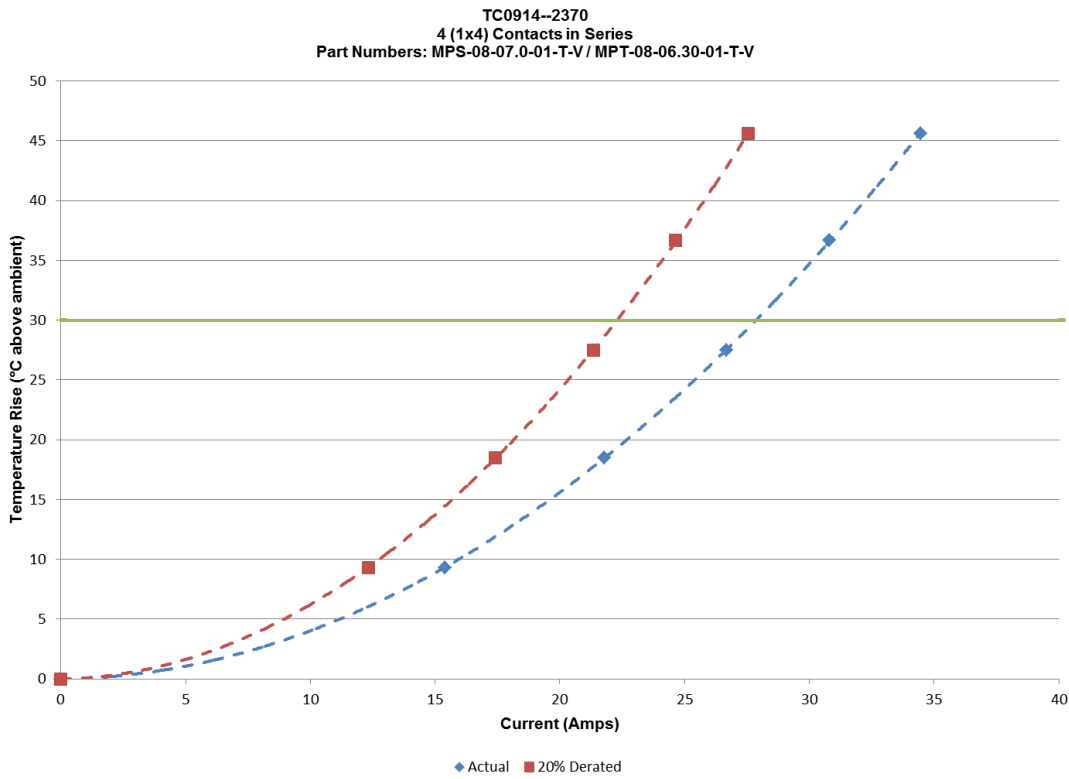
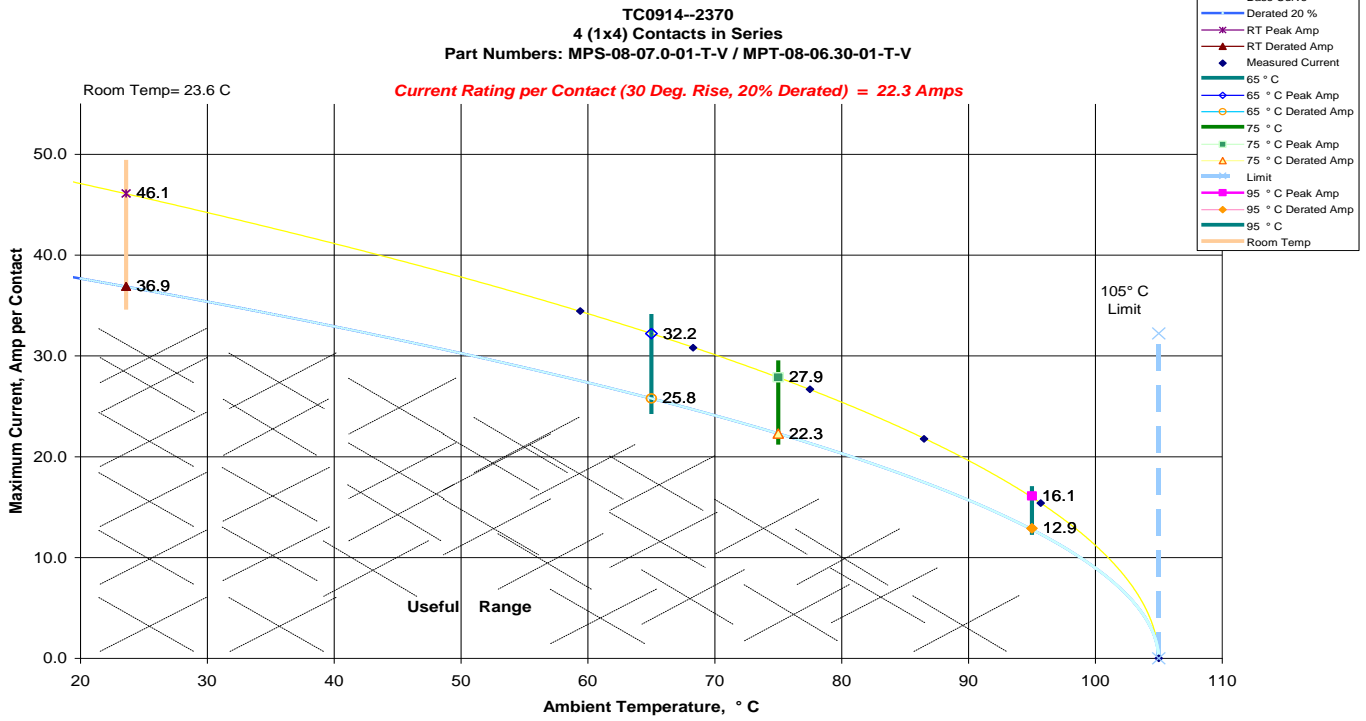

**TEMPERATURE RISE DATA
FOUR ENERGIZED
(Degrees Celsius above ambient)**

TEST CURRENT AMPS	15.4	21.77	26.68	30.81	34.45
Sample 10	8.7	17.4	25.9	34.5	43
Sample 11	10.5	20.9	31.2	41.5	51.7
Sample 12	8.6	17.1	25.5	34	42.2
Min	8.6	17.1	25.5	34	42.2
Max	10.5	20.9	31.2	41.5	51.7
Avg	9.27	18.47	27.53	36.67	45.63

✦ Indicates energized contacts

✦ Indicates thermocouple monitored, energized contacts



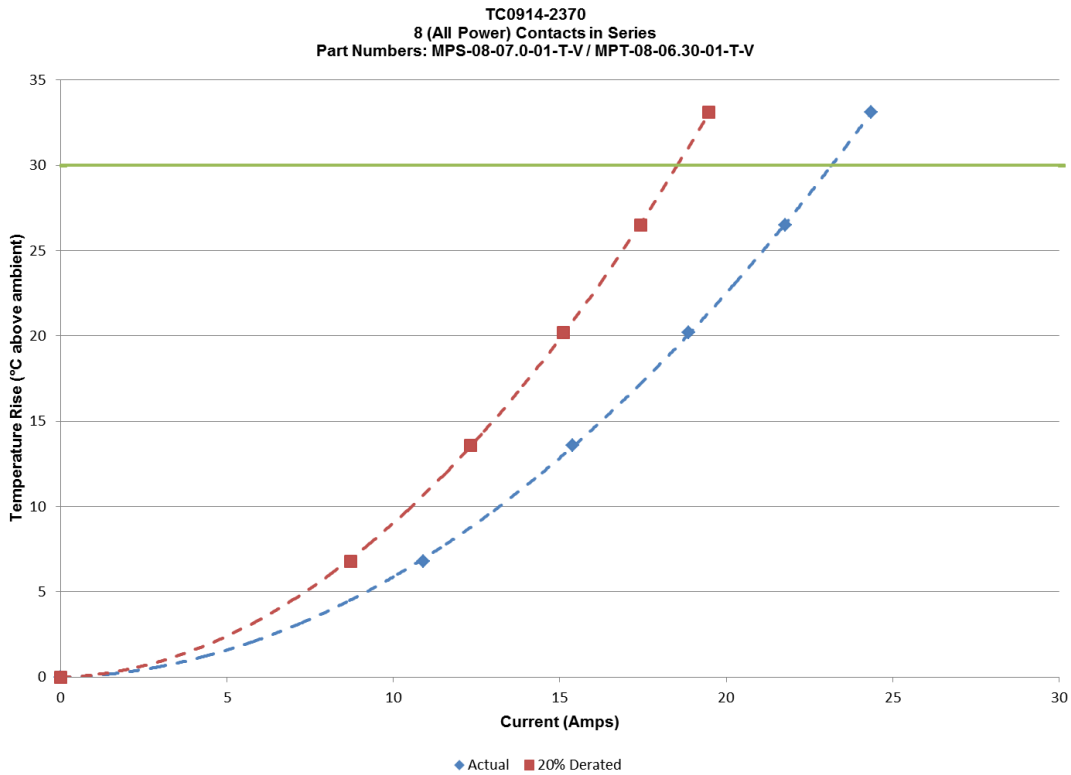
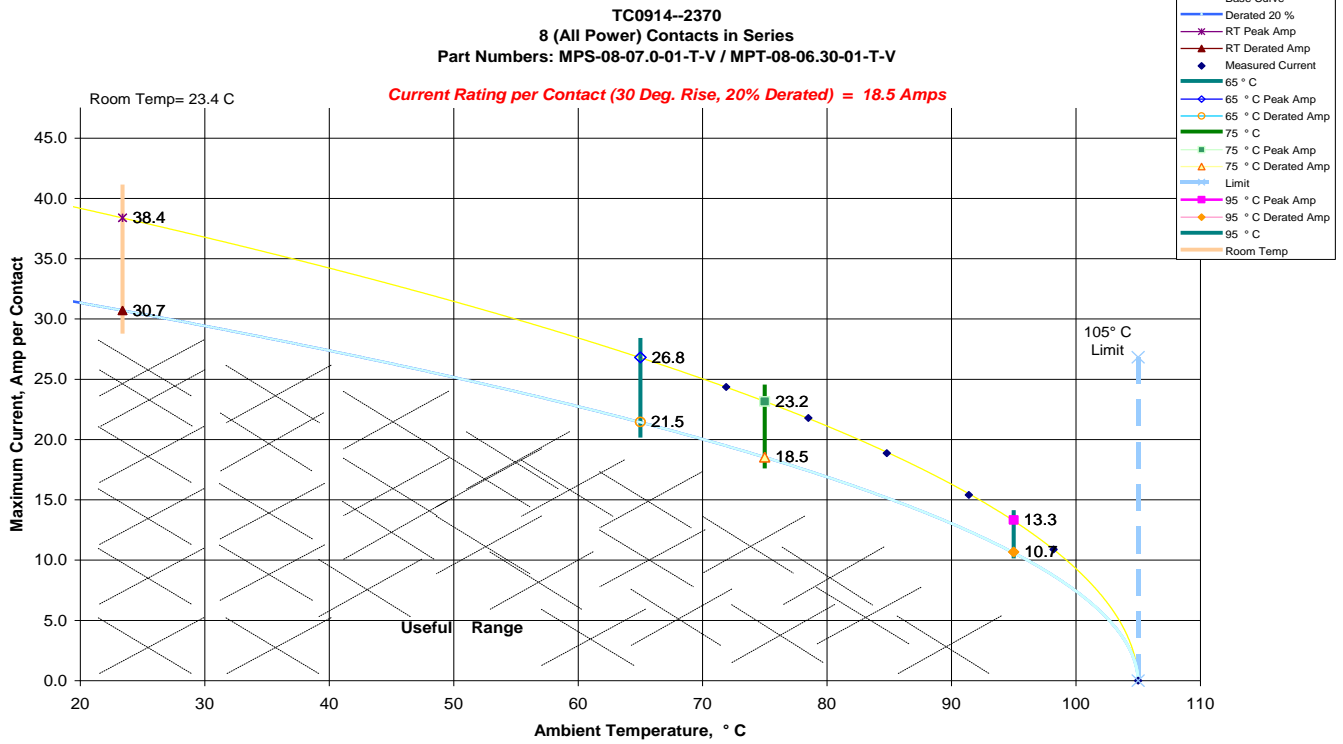

**TEMPERATURE RISE DATA
ALL CONTACTS ENERGIZED
(Degrees Celsius above ambient)**

TEST CURRENT AMPS	10.89	15.4	18.87	21.79	24.36
Sample 13	6.3	12.7	18.9	24.9	31.1
Sample 14	6.3	12.8	18.9	24.9	31.1
Sample 15	7.8	15.3	22.7	29.8	37
Min	6.3	12.7	18.9	24.9	31.1
Max	7.8	15.3	22.7	29.8	37
Avg	6.8	13.6	20.17	26.53	33.07

✦ Indicates energized contacts

✦ Indicates thermocouple monitored, energized contacts

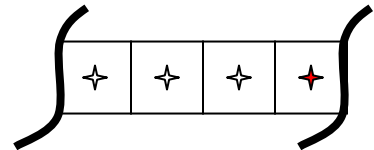

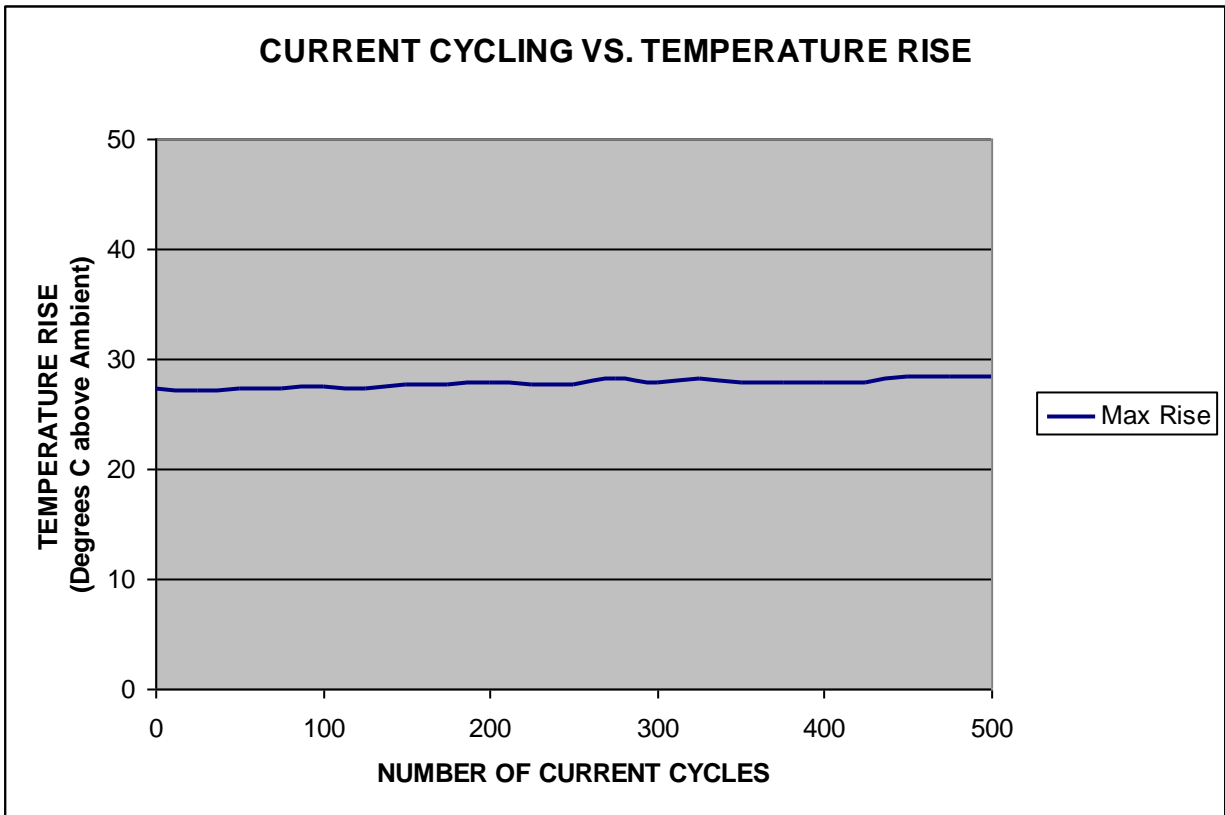

**TEMPERATURE RISE DATA
ALL CONTACTS ENERGIZED
(Degrees Celsius above ambient)**

	INITIAL	50 CYCLES	100 CYCLES	200 CYCLES	500 CYCLES
Min	18.6	18.9	19.2	19.3	19.2
Max	27.2	27.3	27.5	27.8	28.3
Avg	22.4	22.4	22.6	22.7	22.8

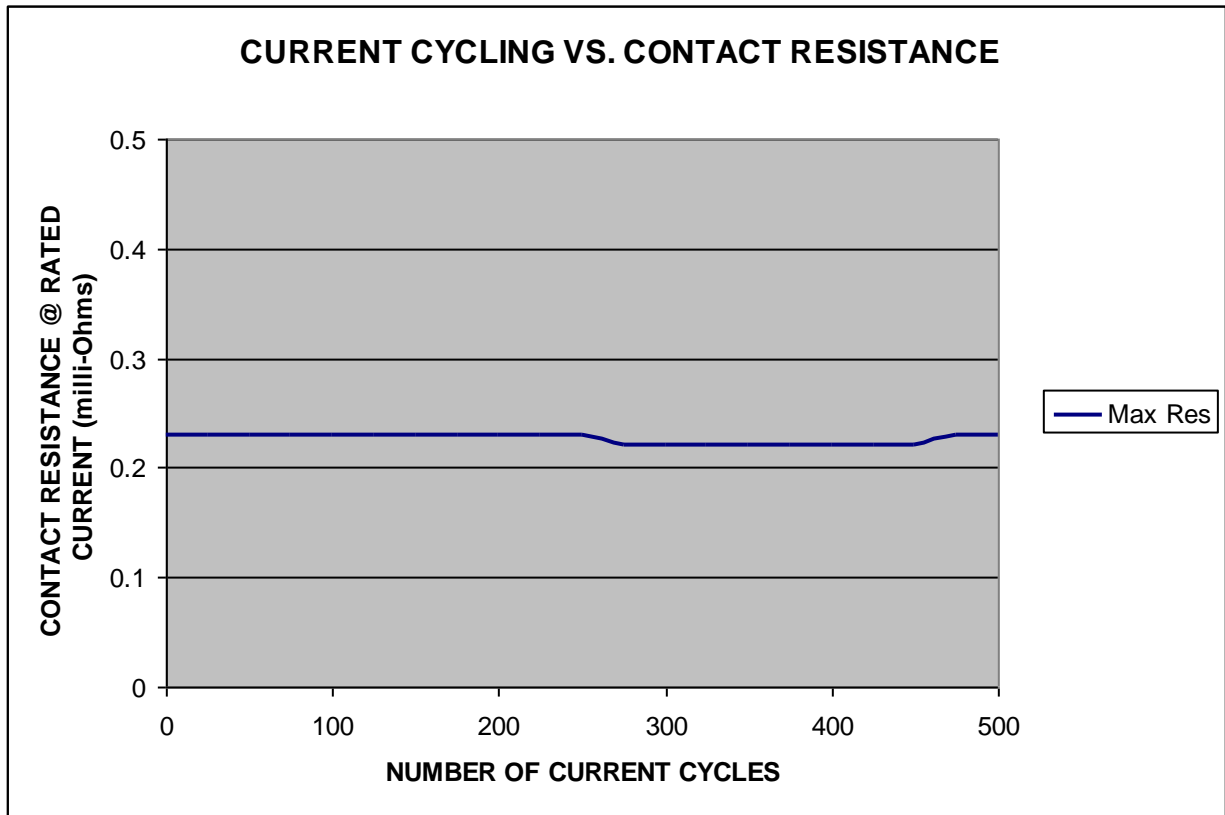

**CONTACT RESISTANCE DATA
ALL CONTACTS ENERGIZED
(mΩ)**

	INITIAL	50 CYCLES	100 CYCLES	200 CYCLES	500 CYCLES
Min	0.15	0.15	0.15	0.15	0.16
Max	0.23	0.23	0.23	0.23	0.23
Avg	0.18	0.18	0.18	0.19	0.19

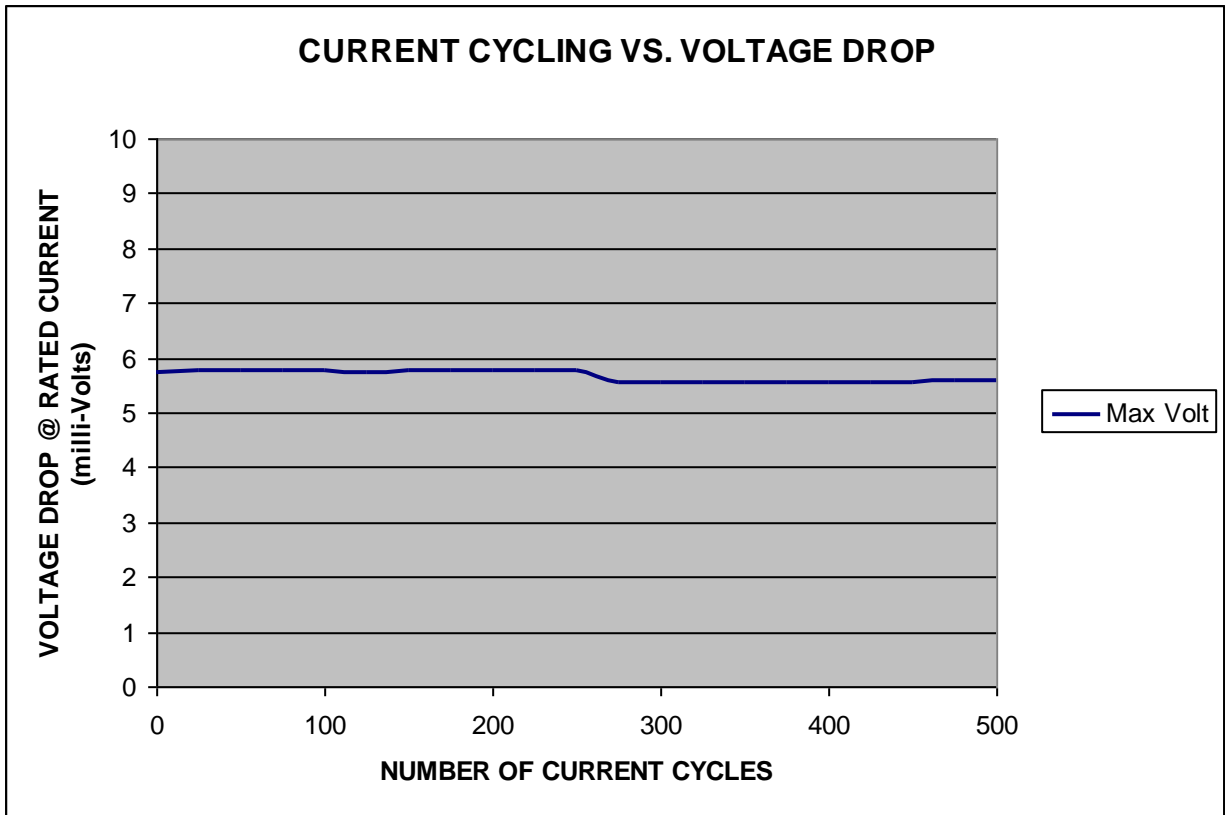

VOLTAGE DROP DATA ALL CONTACTS ENERGIZED mV)					
	INITIAL	50 CYCLES	100 CYCLES	200 CYCLES	500 CYCLES
Min	3.6	3.61	3.61	3.62	3.98
Max	5.73	5.76	5.76	5.77	5.59
Avg	4.55	4.58	4.59	4.62	4.68

EQUIPMENT AND CALIBRATION SCHEDULES

Equipment #: PS-01

Description: System Power Supply

Manufacturer: Hewlett Packard

Model: HP 6033A

Serial #: (HP) 3329A-07330

Accuracy: See Manual

... Last Cal: 06/22/07, Next Cal: 06/22/08

Equipment #: PS-02

Description: System Power Supply, 0 - 20V/ 0 - 30 amp, 200 Watts

Manufacturer: Hewlett Packard

Model: 6033A

Serial #: (HP) 2847A-04167

Accuracy: See Manual

... Last Cal: 03/08/2007, Next Cal: 03/08/2008

Equipment #: PS-03

Description: Power Supply, 50 amp

Manufacturer: HP/Agilent

Model: 0-60V / 0 - 50 amps / 1000 Watts

Serial #: 2723A-02144

Accuracy: See Manual

... Last Cal: 06/22/2007, Next Cal: 06/22/08

Equipment #: PS-04

Description: 60 V, 50 A DC Power Supply - AutoRanging SO

Manufacturer: Hewlett Packard / Agilent

Model: AT-6032A

Serial #: MY41001186

Accuracy: See Manual Current Cycle Chamber 2 - Lower Shelf

... Last Cal: 12/04/2007, Next Cal: 12/04/2008

Equipment #: PS-05

Description: 60 V, 50 A DC Power Supply - AutoRanging SO

Manufacturer: Hewlett Packard / Agilent

Model: AT-6032A

Serial #: MY41001158

Accuracy: See Manual Current Cycle Chamber 2 - Lower Shelf

... Last Cal: 12/04/2007, Next Cal: 12/04/2008

Equipment #: PS-06

Description: 60 V, 50 A DC Power Supply - AutoRanging SO

Manufacturer: Hewlett Packard / Agilent

Model: AT-6032A

Serial #: US35420827

Accuracy: See Manual Current Cycle Chamber 3 (This chamber only has 1 shelf)
... Last Cal: 10/25/2007, Next Cal: 10/25/2008

Equipment #: PS-07

Description: 20 V, 120 A DC Power Supply - AutoRanging SO/HPIB

Manufacturer: Hewlett Packard / Agilent

Model: AT-6031A

Serial #: 2721A00648

Accuracy: See Manual See Manual

... Last Cal: 10/25/2007, Next Cal: 10/25/2008

Equipment #: MO-02

Description: Multimeter /Data Acquisition System

Manufacturer: Keithley

Model: 2700

Serial #: 0780546

Accuracy: See Manual

... Last Cal: 06/22/07, Next Cal: 06/22/08

Equipment #: PS-04

Description: 60 V, 50 A DC Power Supply - AutoRanging SO

Manufacturer: Hewlett Packard / Agilent

Model: AT-6032A

Serial #: MY41001186

Accuracy: See Manual Current Cycle Chamber 2 - Lower Shelf

... Last Cal: 12/04/2007, Next Cal: 12/04/2008

Equipment #: MO-08

Description: Model 2750 Multimeter/Switch System (Integra Series)

Manufacturer: Keithley

Model: 2750

Serial #: WDC-875194

Accuracy: See Manual

... Last Cal: 10/25/2007, Next Cal: 10/27/2008

Equipment #: MO-08

Description: Model 2750 Multimeter/Switch System (Integra Series)

Manufacturer: Keithley

Model: 2750

Serial #: (HP) 3329A-07330

Accuracy: See Manual

... Last Cal: 10/25/2007, Next Cal: 10/27/2008

Equipment #: MO-09
Description: Model 2750 Multimeter/Switch System (Integra Series)
Manufacturer: Keithley
Model: 2750
Serial #: WDC-874817
Accuracy: See Manual
... Last Cal: 10/22/2007, Next Cal: 10/22/2008

Equipment #: TC111307-(001 - 017)
Description: CCC Chamber Thermocouples
Manufacturer: Samtec
Model:
Serial #: TC111307-(001 - 017)
Accuracy: +/- 1 Deg.
... Last Cal: 11/3/2007, Next Cal: 11/3/2008

Equipment #: TC111307-(041 - 059)
Description: Current Cycling Chamber #1 Thermcouples
Manufacturer: Samtec
Model:
Serial #: TC111307-(041 - 059)
Accuracy: +/- 1 Deg.
... Last Cal: 11/3/2007, Next Cal: 11/3/2008

Equipment #: TC111307-(118 - 136)
Description: Current Cycling Chamber # 2 Thermcouples
Manufacturer: Samtec
Model:
Serial #: TC111307-(118 - 136)
Accuracy: +/- 1 Deg.
... Last Cal: 11/03/2007, Next Cal: 11/03/2008

Equipment #: TC120607-(101C - 109C), 110807-140
Description: Current Cycling Chamber # 3 Thermcouples
Manufacturer: Samtec
Model:
Serial #: TC120607-(101C - 109C), 110807-140
Accuracy: +/- 1 Deg.
... Last Cal: 12/06/2007 & 11/08/2007, Next Cal: 12/06/2008 & 11/08/2008