

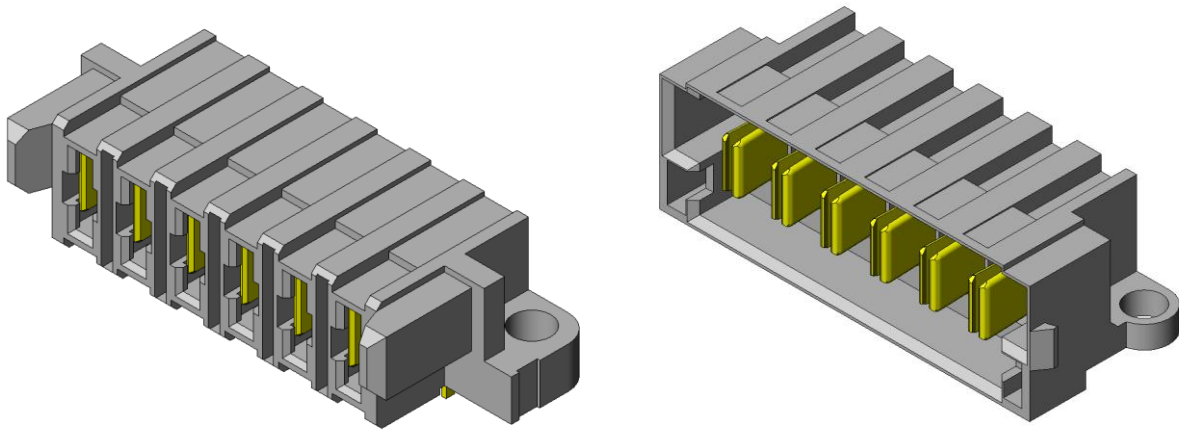

Project Number: Design Verification Test		Tracking Code: TC0905—2213_Report Rev 4		
Requested by: Brandon Harpenau		Date: 5/20/2013	Product Rev: MPS – Rev A, MPT – Rev C	
Part #: MPS-08-01-01-L-RA-SD / MPT-08-01-01-L-RA-SD		Lot #: 0	Tech: Gary Lomax Rodney Riley	Eng: Troy Cook Eric Mings
Part description: Mini Power Strip			Qty to test: 65	
Test Start: 01/27/2009	Test Completed: 4/16/2009			



Design Verification Test Report

PART DESCRIPTION

MPS-08-01-01-L-RA-SD / MPT-08-01-01-L-RA-SD

CERTIFICATION

All instruments and measuring equipment were calibrated to National Institute for Standards and Technology (NIST) traceable standards according to ISO 10012-1 and ANSI/NCSL 2540-1, as applicable.

All contents contained herein are the property of Samtec. No portion of this report, in part or in full shall be reproduced without prior written approval of Samtec.

SCOPE

To perform the following tests: Design verification test. See test plan.

APPLICABLE DOCUMENTS

Standards: EIA Publication 364

TEST SAMPLES AND PREPARATION

- 1) All materials were manufactured in accordance with the applicable product specification.
- 2) All test samples were identified and encoded to maintain traceability throughout the test sequences.
- 3) After soldering, the parts to be used for LLCR and DWV/IR testing were cleaned according to TLWI-0001.
- 4) Either an automated cleaning procedure or an ultrasonic cleaning procedure may be used.
- 5) The automated procedure is used with aqueous compatible soldering materials.
- 6) Parts not intended for testing LLCR and DWV/IR are visually inspected and cleaned if necessary.
- 7) Any additional preparation will be noted in the individual test sequences.
- 8) Solder Information: Lead Free Wave Solder
- 9) Samtec Test PCBs used: PCB-101627-TST-XX / PCB-101628-TST-XX / PCB-101629-TST-XX

FLOWCHARTS

Current Carrying Capacity

3 Mated Assemblies Each

TEST STEP	GROUP A "L" Plating 3 Mated Assemblies 1 CONTACT POWERED	GROUP B "L" Plating 3 Mated Assemblies 2 CONTACTS POWERED	GROUP C "L" Plating 3 Mated Assemblies 3 CONTACTS POWERED	GROUP D "L" Plating 3 Mated Assemblies 4 CONTACTS POWERED	GROUP E "L" Plating 3 Mated Assemblies ALL CONTACTS POWERED
01	CCC	CCC	CCC	CCC	CCC

(TIN PLATING) - Tabulate calculated current at RT, 65° C, 75° C and 95° C
after derating 20% and based on 105° C

(GOLD PLATING) - Tabulate calculated current at RT, 85° C, 95° C and 115° C
after derating 20% and based on 125° C

CCC, Temp rise = EIA-364-70

Mating/Unmating/Gaps/Plating Verification

TEST STEP	GROUP A "L" Plating 10 Boards 80 points	GROUP B "L" Plating Individual Contacts (30) min
01	Contact Gaps	Setup Approve
02	Mating / Unmating	Plating Verification
03	Data Review	Data Review
04	100 Cycles	
05	Mating / Unmating	
06	Contact Gaps	
07	Data Review	
08	Thermal Aging (Mated)	
09	Mating / Unmating	
10	Contact Gaps	
11	Data Review	
12	Humidity (Mated)	
13	Contact Gaps	
14	Mating / Unmating	

Thermal Aging = EIA-364-17, Test Condition 4, 105 deg C;
Time Condition 'B' (250 hours)

Humidity = EIA-364-31, Test Condition B (240 Hours)
and Method III (+25° C to +65° C @ 90%RH to 98% RH)
ambient pre-condition and delete steps 7a and 7b

Mating/Un-Mating Forces = EIA-364-13

Normal Force = EIA-364-04

(Perpendicular) displacement Force = 12.7 mm/min +/- 6 mm/min

Spec is 50 N @ 1 mm displacement

Contact Gaps/Height - No standard method. Usually measured optically

IR & DWV

TEST STEP	GROUP A1 2 Mated Sets Break Down	GROUP A2 2 Unmated of Part # Being Tested Break Down	GROUP A3 2 Unmated of Mating Part # Break Down	GROUP B 2 Mated Sets
01	DWV/Break Down Voltage	DWV/Break Down Voltage	DWV/Break Down Voltage	IR & DWV at test voltage (on both mated sets and on each connector unmated)
02				Thermal Aging (both sets unmated)
03				IR & DWV at test voltage (on both mated sets and on each connector unmated)
04				Cyclic Humidity (both sets unmated)
05				IR & DWV at test voltage (on both mated sets and on each connector unmated)

* - DWV on group B to be performed at Test Voltage

DWV test voltage is equal to 75% of the lowest break down voltage from group A1, A2 or A3

Thermal Aging = EIA-364-17, Test Condition 4 (105 °C)

Time Condition 'B' (250 hours)

Humidity = EIA-364-31, Test Condition B (240 Hours)

and Method III (+25° C to +65° C @ 90%RH to 98% RH)

ambient pre-condition and delete steps 7a and 7b

IR = EIA-364-21

DWV = EIA-364-20

Durability/Thermal Age/Cyclic Humidity

TEST STEP	GROUP A "L" Plating 80 Points 100 Cycles
01	LLCR-1
02	Data Review
03	100 Cycles
04	LLCR-2
05	Data Review
06	Thermal Age
07	LLCR-3
08	Data Review
09	Cyclic Humidity
10	LLCR-4

Thermal Aging = EIA-364-17, Test Condition 4, 105 deg C;

Time Condition 'B' (250 hours)

Humidity =EIA-364-31, Test Condition B (240 Hours)

and Method III (+25 ° C to +65 ° C @ 90%RH to 98% RH)

ambient pre-condition and delete steps 7a and 7b

LLCR = EIA-364-23, LLCR

use Keithley 580 in the dry circuit mode, 10 mA Max

Current Cycling Testing

TEST STEP	GROUP A 8 samples min All contacts wired in series Five contacts wired for voltage drop (or all contacts, whichever is less)
01	500 Current Cycles

Testing to be performed in accordance with EIA-364-55

Test Condition B (125% of Rated current)

Test Method 4 (45 min On / 15 min Off) Temp Rise and Voltage Drop measured at 40 minutes into 'ON' cycle

ATTRIBUTE DEFINITIONS

The following is a brief, simplified description of attributes.

THERMAL:

- 1) EIA-364-17, *Temperature Life with or without Electrical Load Test Procedure for Electrical Connectors*.
- 2) Test Condition 4 at 105° C.
- 3) Test Time Condition B for 250 hours.
- 4) All test samples are pre-conditioned at ambient.
- 5) All test samples are exposed to environmental stressing in the mated condition.

HUMIDITY:

- 1) Reference document: EIA-364-31, *Humidity Test Procedure for Electrical Connectors*.
- 2) Test Condition B, 240 Hours.
- 3) Method III, +25° C to + 65° C, 90% to 98% Relative Humidity excluding sub-cycles 7a and 7b.
- 4) All samples are pre-conditioned at ambient.
- 5) All test samples are exposed to environmental stressing in the mated condition.

TEMPERATURE RISE (Current Carrying Capacity, CCC):

- 1) EIA-364-70, *Temperature Rise versus Current Test Procedure for Electrical Connectors and Sockets*.
- 2) When current passes through a contact, the temperature of the contact increases as a result of I^2R (resistive) heating.
- 3) The number of contacts being investigated plays a significant part in power dissipation and therefore temperature rise.
- 4) The size of the temperature probe can affect the measured temperature.
- 5) Copper traces on PC boards will contribute to temperature rise:
 - a. Self heating (resistive)
 - b. Reduction in heat sink capacity affecting the heated contacts
- 6) A de-rating curve, usually 20%, is calculated.
- 7) Calculated de-rated currents at three temperature points are reported:
 - a. Ambient
 - b. 80° C
 - c. 95° C
 - d. 115° C
- 8) Typically, neighboring contacts (in close proximity to maximize heat build up) are energized.
- 9) The thermocouple (or temperature measuring probe) will be positioned at a location to sense the maximum temperature in the vicinity of the heat generation area.
- 10) A computer program, *TR 803.exe*, ensures accurate stability for data acquisition.
- 11) Hook-up wire cross section is larger than the cross section of any connector leads/PC board traces, jumpers, etc.
- 12) Hook-up wire length is longer than the minimum specified in the referencing standard.

CONTACT GAPS:

- 1) Gaps above the surrounding plastic surface were measured before and after stressing the contacts (e.g. thermal aging, mechanical cycling, etc.).
- 2) Typically, all contacts on the connector are measured.

MATING/UNMATING:

- 1) Reference document: EIA-364-13, *Mating and Unmating Forces Test Procedure for Electrical Connectors*.
- 2) The full insertion position was to within 0.003” to 0.004” of the plug bottoming out in the receptacle to prevent damage to the system under test.
- 3) One of the mating parts is secured to a floating X-Y table to prevent damage during cycling.

NORMAL FORCE (FOR CONTACTS TESTED IN THE HOUSING):

- 1) Reference document: EIA-364-04, *Normal Force Test Procedure for Electrical Connectors*.
- 2) The contacts shall be tested in the connector housing.
- 3) If necessary, a “window” shall be made in the connector body to allow a probe to engage and deflect the contact at the same attitude and distance (plus 0.05 mm [0.002”]) as would occur in actual use.
- 4) The connector housing shall be placed in a holding fixture that does not interfere with or otherwise influence the contact force or deflection.
- 5) Said holding fixture shall be mounted on a floating, adjustable, X-Y table on the base of the Dillon TC², computer controlled test stand with a deflection measurement system accuracy of 5.0 µm (0.0002”).
- 6) The nominal deflection rate shall be 5 mm (0.2”)/minute.
- 7) Unless otherwise noted a minimum of five contacts shall be tested.
- 8) The force/deflection characteristic to load and unload each contact shall be repeated five times.
- 9) The system shall utilize the TC² software in order to acquire and record the test data.
- 10) The permanent set of each contact shall be measured within the TC² software.
- 11) The acquired data shall be graphed with the deflection data on the X-axis and the force data on the Y-axis and a print out will be stored with the Tracking Code paperwork.

INSULATION RESISTANCE (IR):

To determine the resistance of insulation materials to leakage of current through or on the surface of these materials when a DC potential is applied.

- 1) PROCEDURE:
 - a. Reference document: EIA-364-21, *Insulation Resistance Test Procedure for Electrical Connectors*.
 - b. Test Conditions:
 - i. Between Adjacent Contacts or Signal-to-Ground
 - ii. Electrification Time 2.0 minutes
 - iii. Test Voltage (500 VDC) corresponds to calibration settings for measuring resistances.
- 2) MEASUREMENTS:
- 3) When the specified test voltage is applied (VDC), the insulation resistance shall not be less than 5000 megohms.

DIELECTRIC WITHSTANDING VOLTAGE (DWV):

To determine if the sockets can operate at its rated voltage and withstand momentary over potentials due to switching, surges, and other similar phenomenon. Separate samples are used to evaluate the effect of environmental stresses so not to influence the readings from arcing that occurs during the measurement process.

- 1) PROCEDURE:
 - a. Reference document: EIA-364-20, *Withstanding Voltage Test Procedure for Electrical Connectors*.
 - b. Test Conditions:
 - i. Between Adjacent Contacts or Signal-to-Ground
 - ii. Barometric Test Condition 1
 - iii. Rate of Application 500 V/Sec
 - iv. Test Voltage (VAC) until breakdown occurs
- 2) MEASUREMENTS/CALCULATIONS
 - a. The breakdown voltage shall be measured and recorded.
 - b. The dielectric withstanding voltage shall be recorded as 75% of the minimum breakdown voltage.
 - c. The working voltage shall be recorded as one-third (1/3) of the dielectric withstanding voltage (one-fourth of the breakdown voltage).

LLCR:

- 1) EIA-364-23, *Low Level Contact Resistance Test Procedure for Electrical Connectors and Sockets*.
- 2) A computer program, *LLCR 221.exe*, ensures repeatability for data acquisition.
- 3) The following guidelines are used to categorize the changes in LLCR as a result from stressing
 - a. $\leq +5.0$ mOhms:----- Stable
 - b. $+5.1$ to $+10.0$ mOhms:----- Minor
 - c. $+10.1$ to $+15.0$ mOhms:----- Acceptable
 - d. $+15.1$ to $+50.0$ mOhms:----- Marginal
 - e. $+50.1$ to $+2000$ mOhms:----- Unstable
 - f. $>+2000$ mOhms:----- Open Failure

CURRENT CYCLING:

- 1) Reference document: EIA-364-55, *Current Cycling Test Procedure for Electrical Connectors*.
- 2) Reference document: EIA-364-06, *Contact Resistance Test Procedure for Electrical Connectors*.
 - a. This is a four-wire measurement.
- 3) An uninterruptible Power Supply maintained power to appropriate equipment.
 - a. A microprocessor controlled cycling fixture maintained accurate duty-cycle timing for test duration.
 - b. A calibrated constant current source provided consistent DC power during ON cycles

RESULTS

Temperature Rise, CCC at a 20% de-rating

- CCC for a 30°C Temperature Rise -----23.3A per contact with 1 contact powered
- CCC for a 30°C Temperature Rise -----20.5A per contact with 2 adjacent contacts powered
- CCC for a 30°C Temperature Rise -----19.4A per contact with 3 adjacent contacts powered
- CCC for a 30°C Temperature Rise -----18.4A per contact with 4 adjacent contacts powered
- CCC for a 30°C Temperature Rise -----17.2A per contact with all adjacent contacts powered

Contact Gaps

- **Initial**
 - Min ----- 1.8220 mm
 - Max ----- 1.9780 mm
- **After 100 Cycles**
 - Min ----- 1.8200 mm
 - Max ----- 1.9500 mm
- **Thermal**
 - Min ----- 1.8300 mm
 - Max ----- 1.9500 mm
- **Humidity**
 - Min ----- 1.8260 mm
 - Max ----- 1.9820 mm

Mating – Unmating Forces

- **Initial**
 - **Mating**
 - **Min** ----- 6.49 Lbs
 - **Max** ----- 9.20 Lbs
 - **Unmating**
 - **Min** ----- 5.85 Lbs
 - **Max** ----- 7.30 Lbs
- **After 25 Cycles**
 - **Mating**
 - **Min** ----- 7.39 Lbs
 - **Max** ----- 9.60 Lbs
 - **Unmating**
 - **Min** ----- 6.69 Lbs
 - **Max** ----- 8.80 Lbs
- **After 50 Cycles**
 - **Mating**
 - **Min** ----- 7.47 Lbs
 - **Max** ----- 10.00 Lbs
 - **Unmating**
 - **Min** ----- 7.45 Lbs
 - **Max** ----- 10.00 Lbs
- **After 75 Cycles**
 - **Mating**
 - **Min** ----- 7.86 Lbs
 - **Max** ----- 10.60 Lbs
 - **Unmating**
 - **Min** ----- 8.08 Lbs
 - **Max** ----- 10.60 Lbs
- **After 100 Cycles**
 - **Mating**
 - **Min** ----- 8.50 Lbs
 - **Max** ----- 11.10 Lbs
 - **Unmating**
 - **Min** ----- 8.62 Lbs
 - **Max** ----- 11.20 Lbs
- **Thermal**
 - **Mating**
 - **Min** ----- 5.87 Lbs
 - **Max** ----- 7.20 Lbs
 - **Unmating**
 - **Min** ----- 5.81 Lbs
 - **Max** ----- 7.40 Lbs
- **Humidity**
 - **Mating**
 - **Min** ----- 6.02 Lbs
 - **Max** ----- 7.10 Lbs
 - **Unmating**
 - **Min** ----- 5.51 Lbs
 - **Max** ----- 7.10 Lbs

Normal Force at 0.013” deflection

- **Initial**
 - **Min**----- 628.50 g **Set ---- 0.0002”**
 - **Max** ----- 858.20 g **Set ---- 0.0021”**
- **Thermal**
 - **Min**----- 596.40 g
 - **Max** ----- 996.40 g

Insulation Resistance minimums, IR Pin-to-Pin

- **Initial**
 - **Mated**-----100,000 Meg Ω ----- **Pass**
 - **Unmated** -----100,000 Meg Ω ----- **Pass**
- **Thermal**
 - **Mated**-----100,000 Meg Ω ----- **Pass**
 - **Unmated** -----100,000 Meg Ω ----- **Pass**
- **Humidity**
 - **Mated**----- 12,000 Meg Ω ----- **Pass**
 - **Unmated** ----- 12,000 Meg Ω ----- **Pass**

Dielectric Withstanding Voltage minimums, DWV Pin-to-Pin

- **Minimums**
 - **Breakdown Voltage**----- 2400 VAC
 - **Test Voltage** ----- 1800 VAC
 - **Working Voltage** -----600 VAC
- **Initial DWV** -----Passed
- **Thermal DWV**-----Passed
- **Humidity DWV**-----Passed

LLCR Durability (80 LLCR test points)

- **Initial** -----0.5 mOhms Max
- **Durability, 100 Cycles**
 - **<= +5.0 mOhms** -----80 Points ----- **Stable**
 - **+5.1 to +10.0 mOhms** -----0 Points ----- **Minor**
 - **+10.1 to +15.0 mOhms** -----0 Points ----- **Acceptable**
 - **+15.1 to +50.0 mOhms** -----0 Points ----- **Marginal**
 - **+50.1 to +2000 mOhms** -----0 Points ----- **Unstable**
 - **>+2000 mOhms** -----0 Points ----- **Open Failure**
- **Thermal**
 - **<= +5.0 mOhms** -----80 Points ----- **Stable**
 - **+5.1 to +10.0 mOhms** -----0 Points ----- **Minor**
 - **+10.1 to +15.0 mOhms** -----0 Points ----- **Acceptable**
 - **+15.1 to +50.0 mOhms** -----0 Points ----- **Marginal**
 - **+50.1 to +2000 mOhms** -----0 Points ----- **Unstable**
 - **>+2000 mOhms** -----0 Points ----- **Open Failure**
- **Humidity**
 - **<= +5.0 mOhms** -----80 Points ----- **Stable**
 - **+5.1 to +10.0 mOhms** -----0 Points ----- **Minor**
 - **+10.1 to +15.0 mOhms** -----0 Points ----- **Acceptable**
 - **+15.1 to +50.0 mOhms** -----0 Points ----- **Marginal**
 - **+50.1 to +2000 mOhms** -----0 Points ----- **Unstable**
 - **>+2000 mOhms** -----0 Points ----- **Open Failure**

Current Cycling – 500 Cycles, 45 minutes ON and 15 minutes OFF

- **Test Current -----21.5 A**
- **Temperature Change, Measured 30 minutes into the FIRST and LAST ON cycle**
 - **Initial Temperature Change -----30.225°C**
 - **Final Temperature Change -----28.525°C**

DATA SUMMARIES

TEMPERATURE RISE (Current Carrying Capacity, CCC):

- 1) High quality thermocouples whose temperature slopes track one another were used for temperature monitoring.
- 2) The thermocouples were placed at a location to sense the maximum temperature generated during testing.
- 3) Temperature readings recorded are those for which three successive readings, 15 minutes apart, differ less than 1° C (computer controlled data acquisition).
- 4) Adjacent contacts were powered:

a. Linear configuration with 1 conductor/contact powered

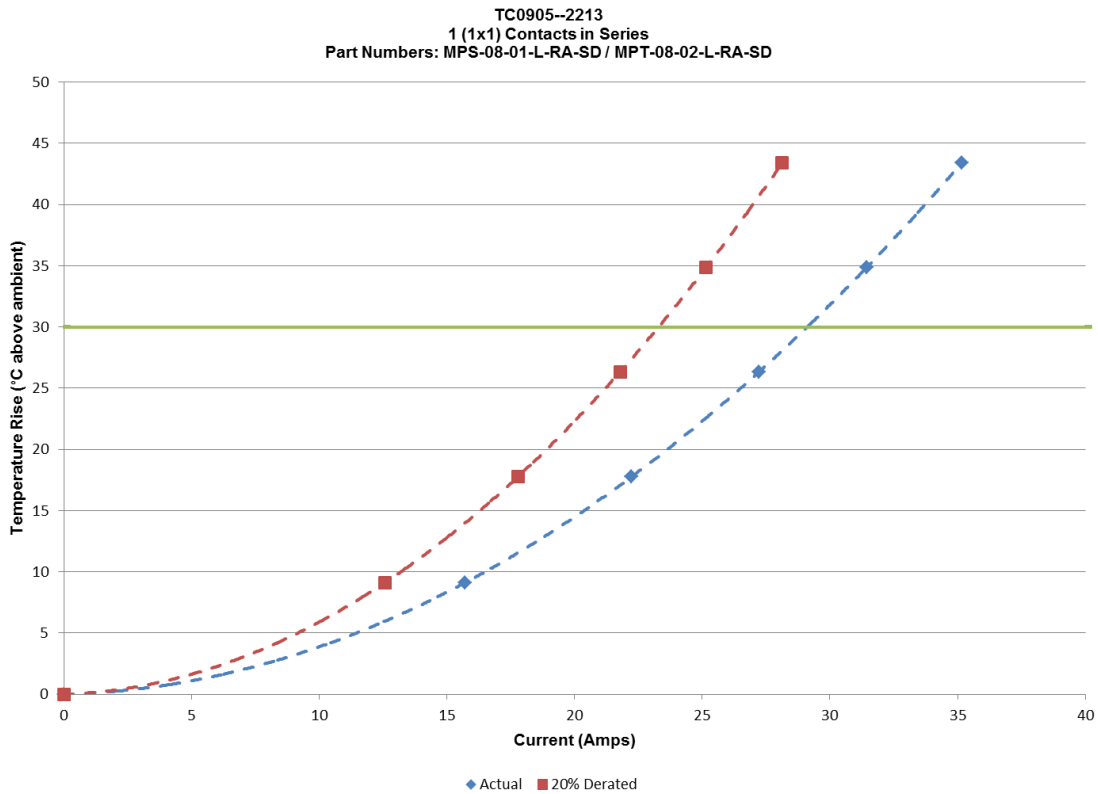
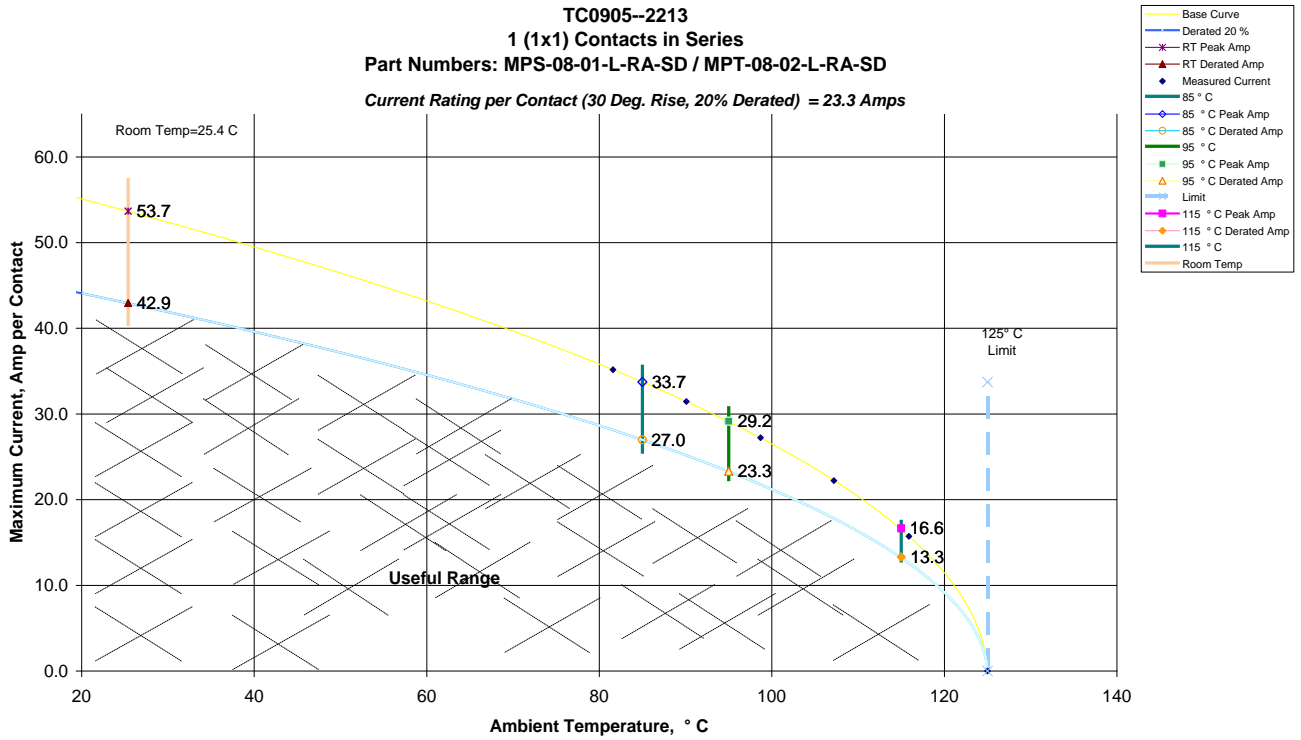

b. Linear configuration with 2 adjacent conductors/contacts powered

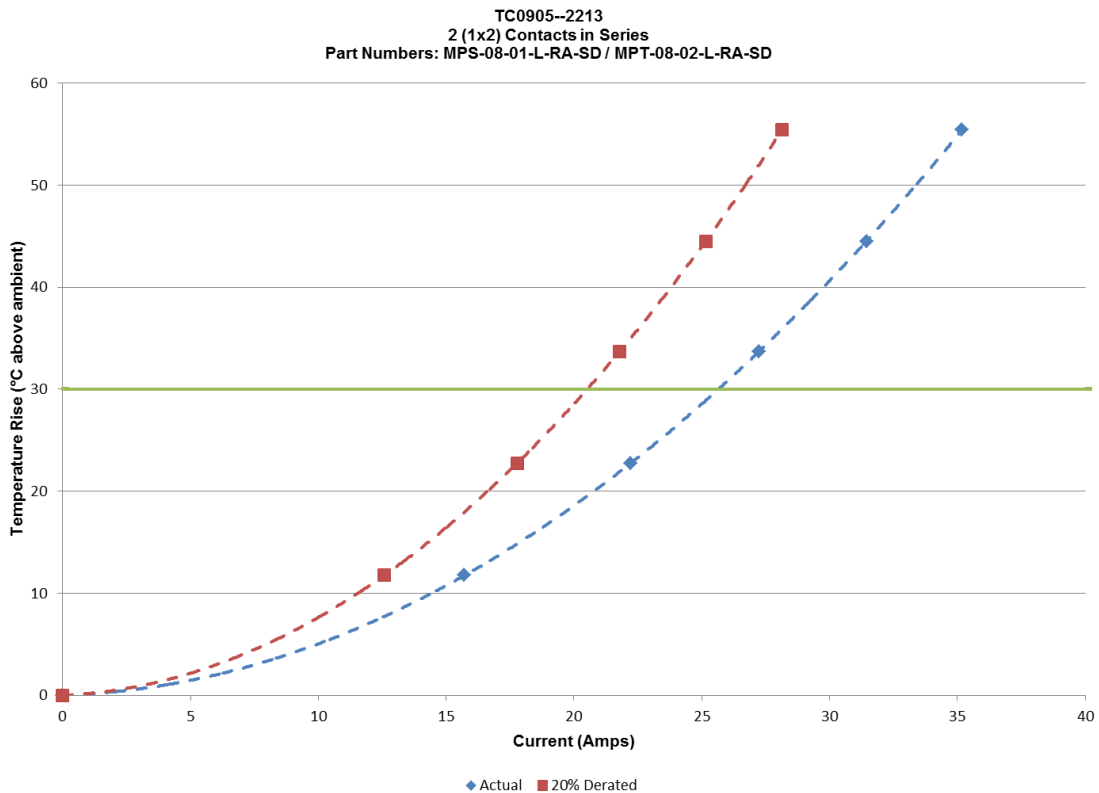
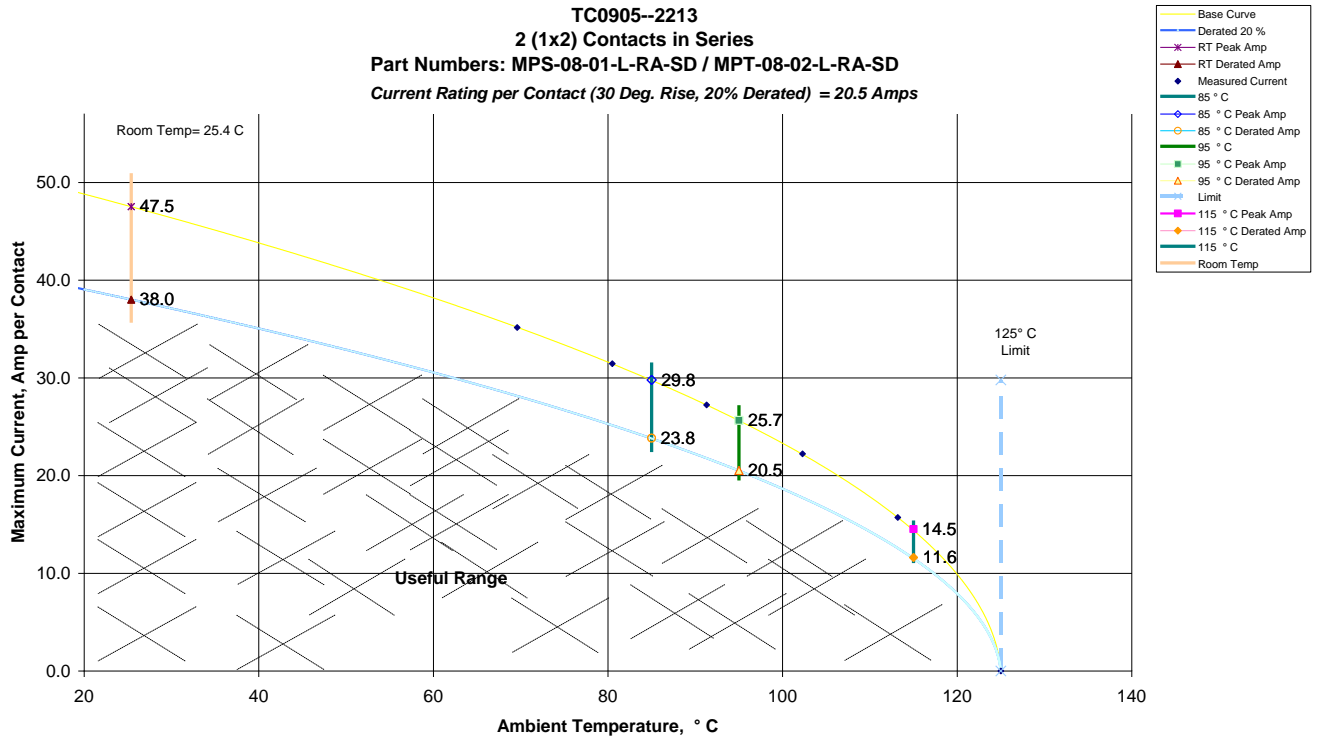

c. Linear configuration with 3 adjacent conductors/contacts powered

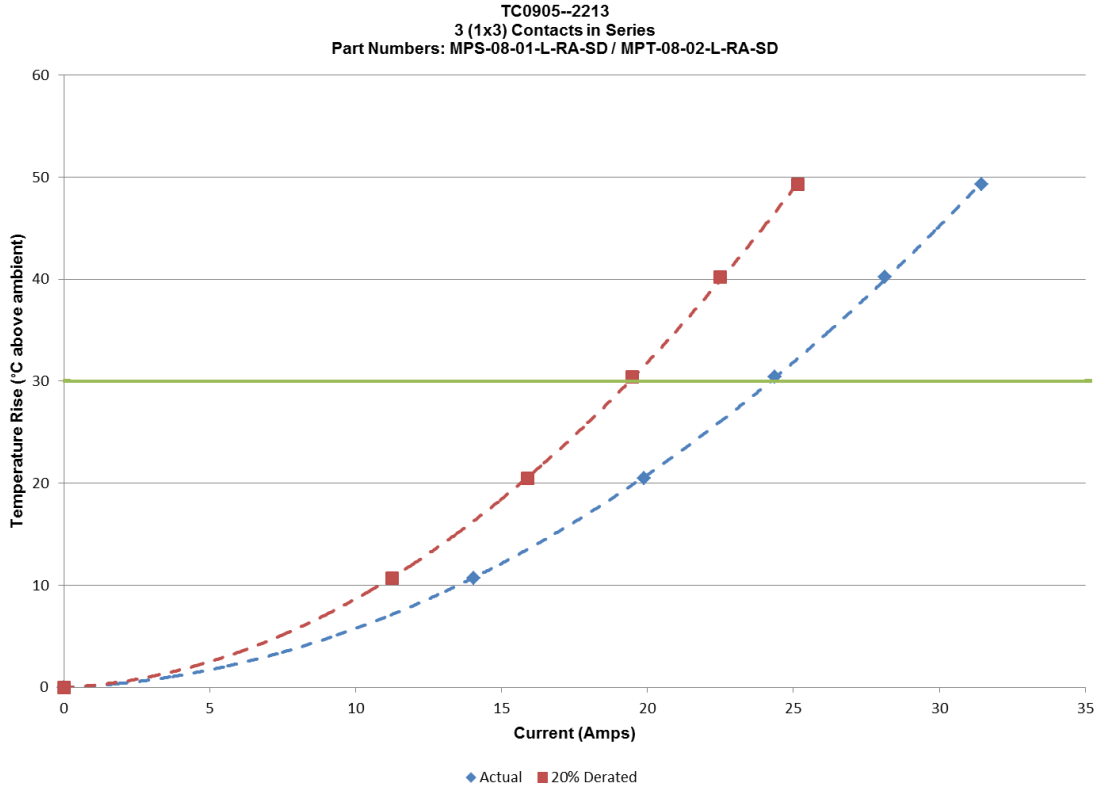
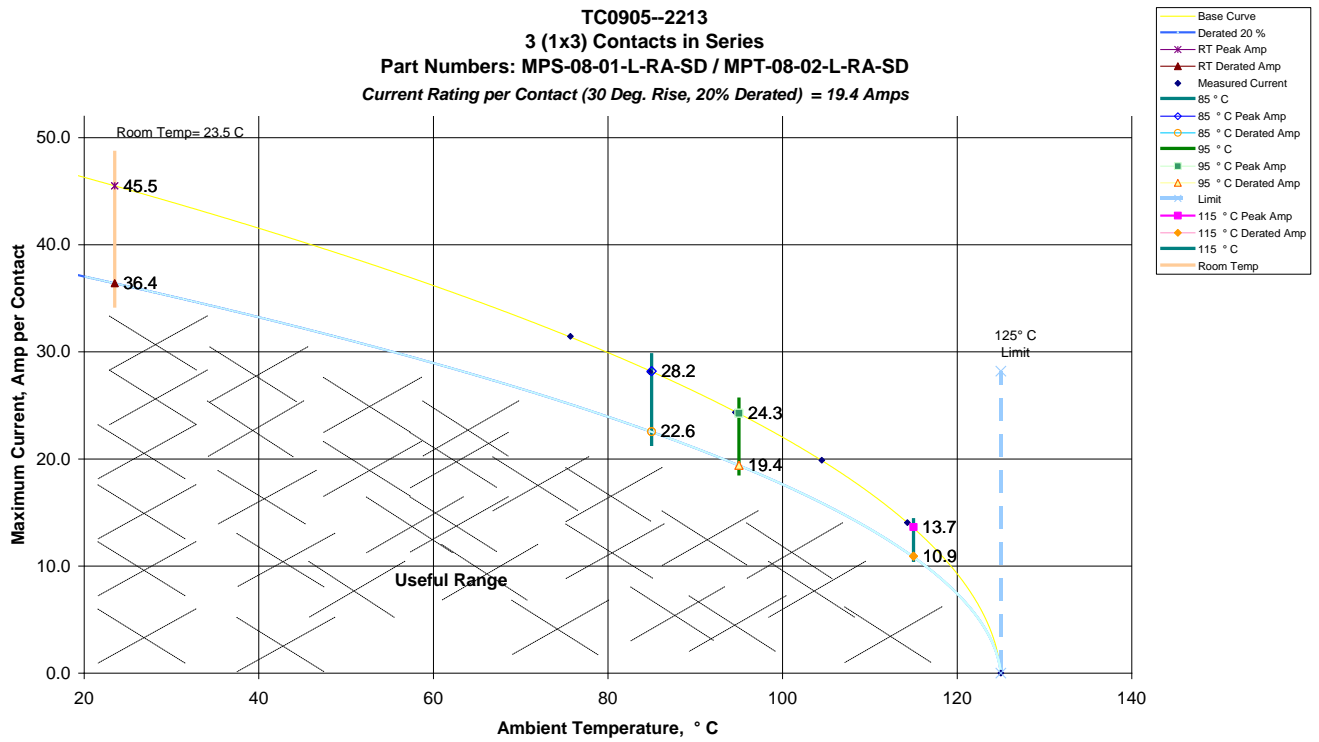

d. Linear configuration with 4 adjacent conductors/contacts powered

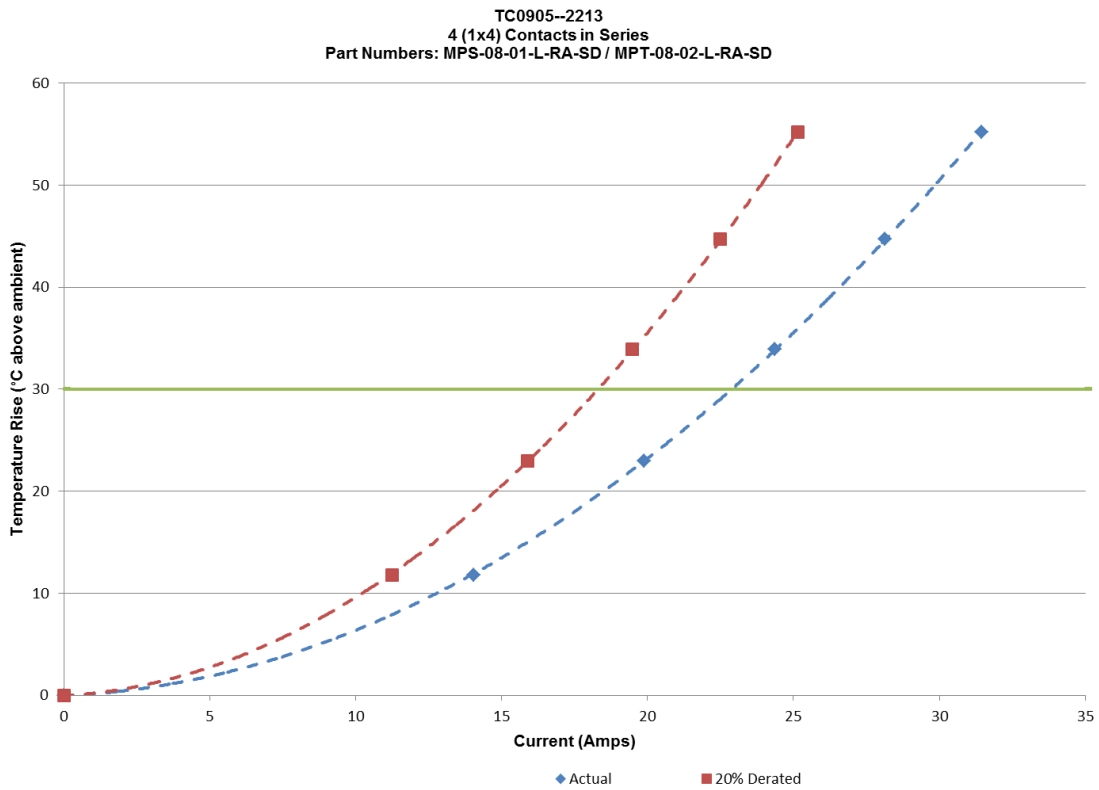
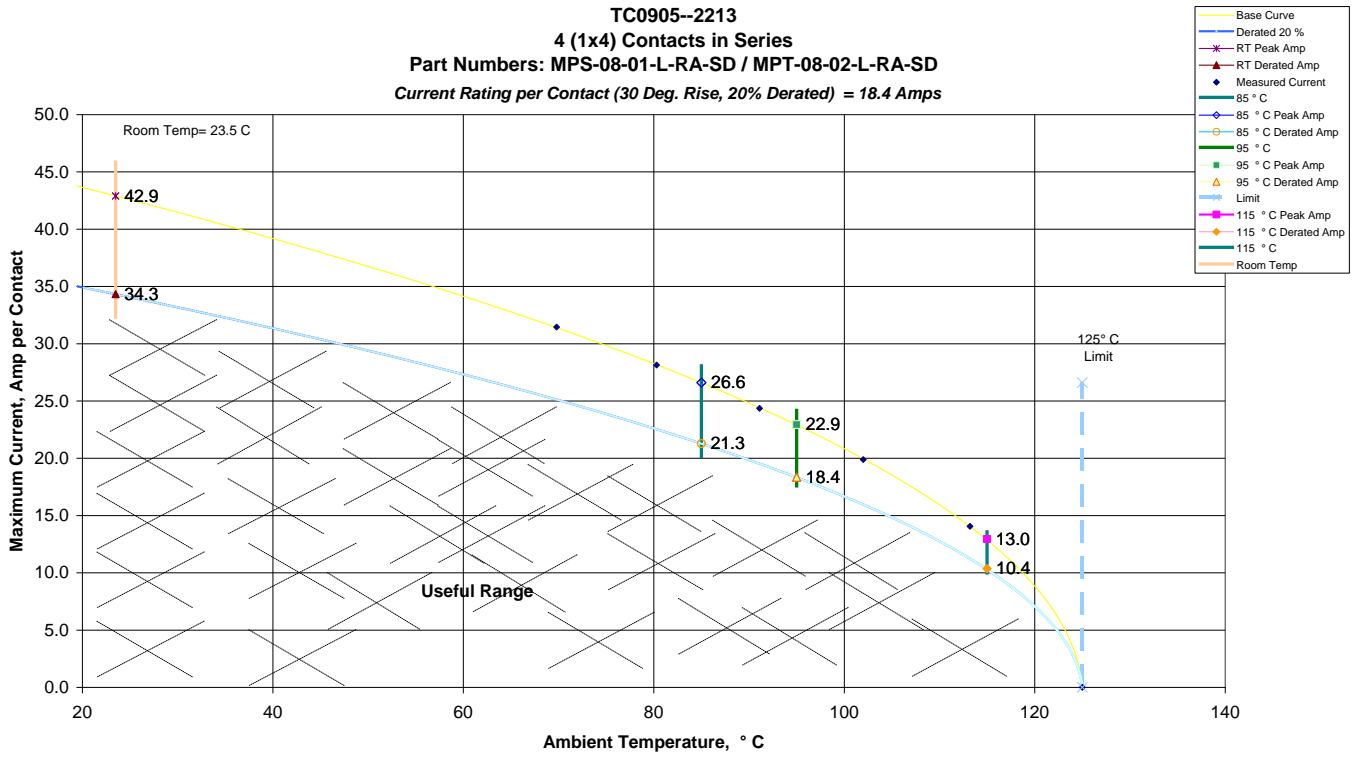

e. Linear configuration with all adjacent conductors/contacts powered

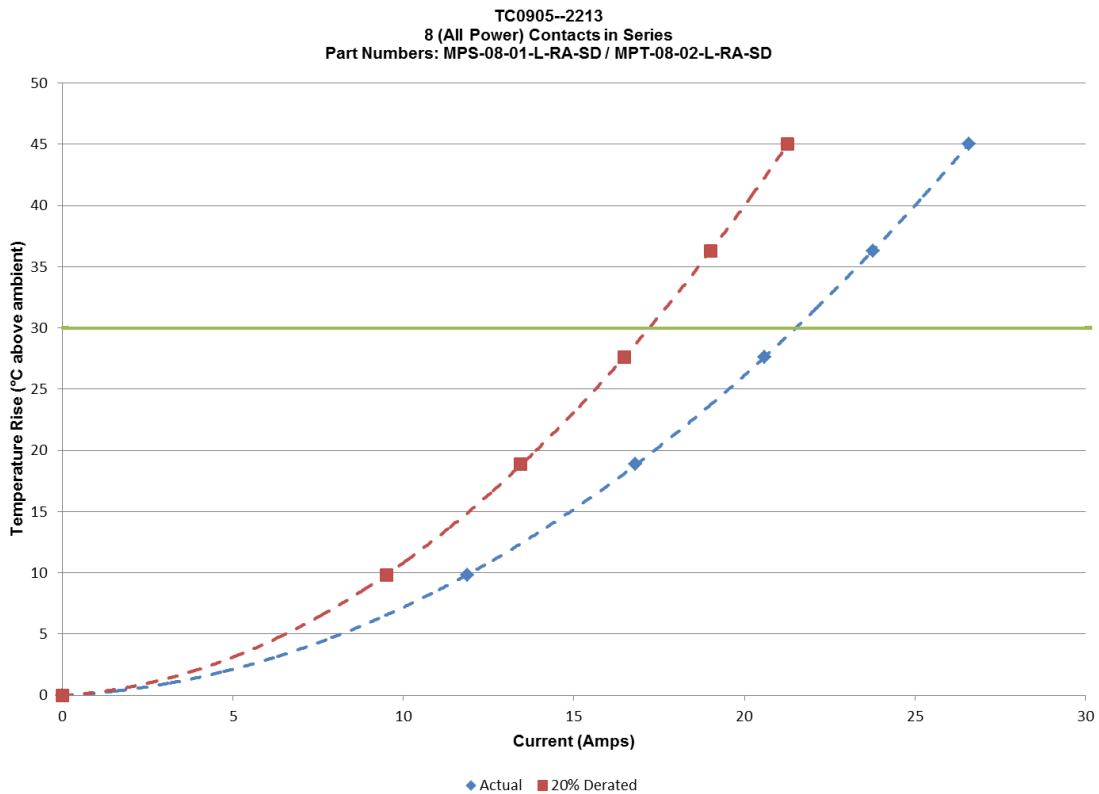
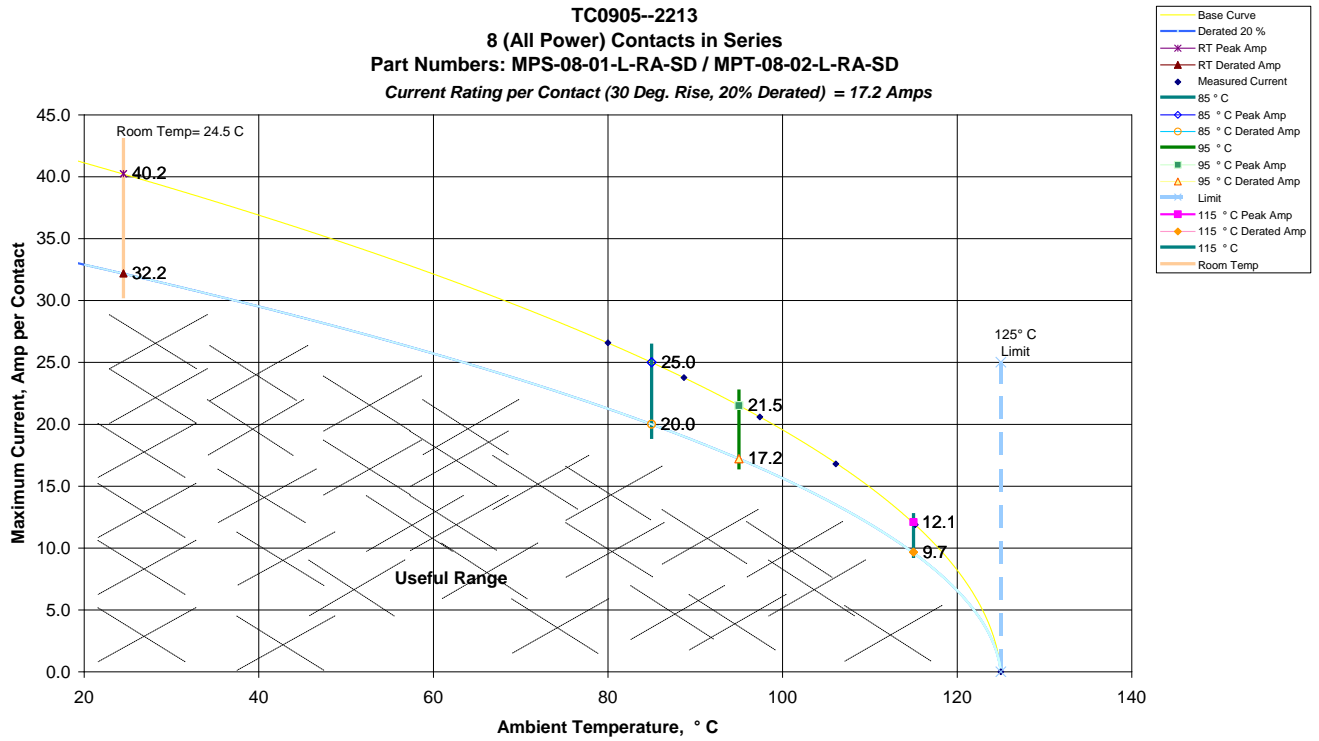

CONTACT GAPS:

Initial		After 100 Cycles		Thermal		Humidity	
Measured in mm		Measured in mm		Measured in mm		Measured in mm	
<i>Minimum</i>	1.8220	<i>Minimum</i>	1.8200	<i>Minimum</i>	1.8300	<i>Minimum</i>	1.8260
<i>Maximum</i>	1.9780	<i>Maximum</i>	1.9500	<i>Maximum</i>	1.9500	<i>Maximum</i>	1.9820
<i>Average</i>	1.9184	<i>Average</i>	1.8887	<i>Average</i>	1.8939	<i>Average</i>	1.8965
<i>St. Dev.</i>	0.0352	<i>St. Dev.</i>	0.0328	<i>St. Dev.</i>	0.0295	<i>St. Dev.</i>	0.0370
<i>Count</i>	80	<i>Count</i>	80	<i>Count</i>	80	<i>Count</i>	80

MATING/UNMATING:

	Initial				After 25 Cycles			
	Mating		Unmating		Mating		Unmating	
	Force (Oz)	Force (Lbs)	Force (Oz)	Force (Lbs)	Force (Oz)	Force (Lbs)	Force (Oz)	Force (Lbs)
Minimum	103.9	6.49	93.5	5.85	118.2	7.39	107.1	6.69
Maximum	147.7	9.2	116.6	7.3	153.3	9.6	140.2	8.8
Average	120.7	7.5	105.8	6.6	131.8	8.2	121.6	7.6
	After 50 Cycles				After 75 Cycles			
	Mating		Unmating		Mating		Unmating	
	Force (Oz)	Force (Lbs)	Force (Oz)	Force (Lbs)	Force (Oz)	Force (Lbs)	Force (Oz)	Force (Lbs)
Minimum	119.6	7.47	119.2	7.45	125.8	7.86	129.3	8.08
Maximum	160.3	10.0	159.2	10.0	169.8	10.6	170.2	10.6
Average	143.3	9.0	138.8	8.7	150.8	9.4	147.5	9.2
	After 100 Cycles				After Thermals			
	Mating		Unmating		Mating		Unmating	
	Force (Oz)	Force (Lbs)	Force (Oz)	Force (Lbs)	Force (Oz)	Force (Lbs)	Force (Oz)	Force (Lbs)
Minimum	136.0	8.50	137.9	8.62	93.9	5.87	93.0	5.81
Maximum	177.4	11.1	178.6	11.2	114.4	7.2	118.9	7.4
Average	156.9	9.8	154.2	9.6	103.8	6.5	103.7	6.5
	After Humidity							
	Mating		Unmating					
	Force (Oz)	Force (Lbs)	Force (Oz)	Force (Lbs)				
Minimum	96.3	6.02	88.2	5.51				
Maximum	113.4	7.1	114.1	7.1				
Average	101.3	6.3	99.7	6.2				

NORMAL FORCE (FOR CONTACTS TESTED IN THE HOUSING):

- 1) Calibrated force gauges are used along with computer controlled positioning equipment.
- 2) For Normal force 8-10 measurements are taken and the averages reported.

Normal Force - Average Initial vs Average Thermal

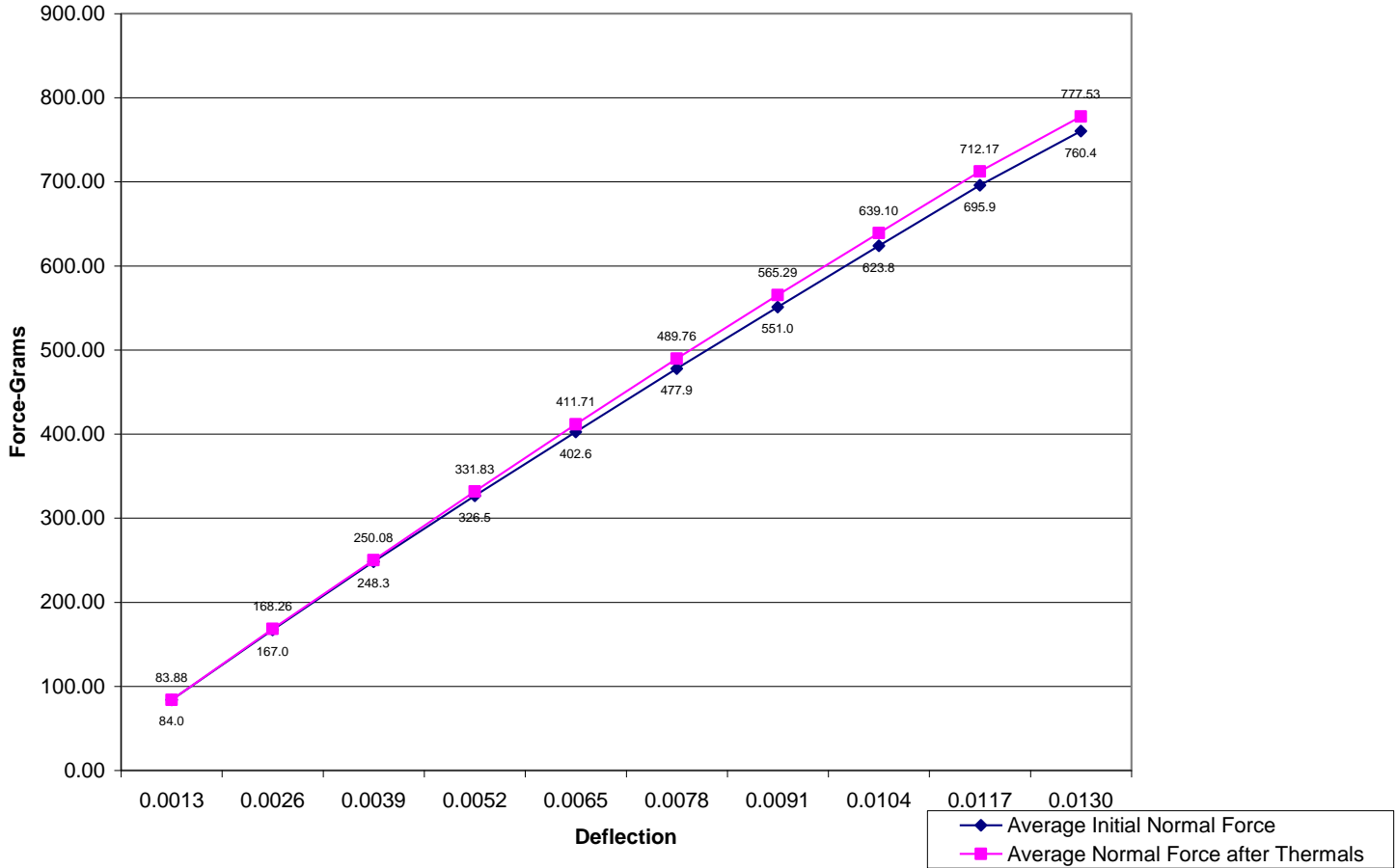

Initial	Deflections in inches Forces in Grams										
	<u>0.0013</u>	<u>0.0026</u>	<u>0.0039</u>	<u>0.0052</u>	<u>0.0065</u>	<u>0.0078</u>	<u>0.0091</u>	<u>0.0104</u>	<u>0.0117</u>	<u>0.0130</u>	<i>SET</i>
Averages	83.98	167.02	248.28	326.45	402.56	477.93	550.97	623.83	695.88	760.37	0.0007
Min	66.00	141.20	211.50	278.90	343.10	406.10	467.70	524.90	575.50	628.50	0.0002
Max	111.10	203.30	300.30	390.40	474.00	553.00	630.80	718.30	802.80	858.20	0.0021
St. Dev	11.552	16.423	23.445	30.682	37.356	44.908	52.155	60.175	67.687	67.699	0.0007
Count	12	12	12	12	12	12	12	12	12	12	12

After Thermals	Deflections in inches Forces in Grams										
	<u>0.0013</u>	<u>0.0026</u>	<u>0.0039</u>	<u>0.0052</u>	<u>0.0065</u>	<u>0.0078</u>	<u>0.0091</u>	<u>0.0104</u>	<u>0.0117</u>	<u>0.0130</u>	<i>SET</i>
Averages	83.88	168.26	250.08	331.83	411.71	489.76	565.29	639.10	712.17	777.53	0.0004
Min	62.60	125.20	187.80	248.80	308.80	367.40	425.50	484.10	539.80	596.40	0.0001
Max	109.80	216.90	318.70	428.30	529.60	628.20	726.50	835.90	940.20	996.40	0.0009
St. Dev	12.827	23.591	34.751	48.442	61.042	74.589	87.649	98.656	108.942	108.695	0.0003
Count	12	12	12	12	12	12	12	12	12	12	12

INSULATION RESISTANCE (IR):

Minimum	Pin to Pin		
	Mated	Unmated	Unmated
	MPS/MPT	MPS	MPT
Initial	100000	100000	100000
Thermal	100000	100000	100000
Humidity	12000	100000	12000

DIELECTRIC WITHSTANDING VOLTAGE (DWV):

Voltage Rating Summary	
Minimum	MPS/MPT
Break Down Voltage	2400
Test Voltage	1800
Working Voltage	600

Pin to Pin	
Initial Test Voltage	Passed
After Thermal Test Voltage	Passed
After Humidity Test Voltage	Passed

LLCR:

- 1) A total of 80 points were measured.
- 2) EIA-364-23, *Low Level Contact Resistance Test Procedure for Electrical Connectors and Sockets*.
- 3) A computer program, *LLCR 221.exe*, ensures repeatability for data acquisition.
- 4) The following guidelines are used to categorize the changes in LLCR as a result from stressing.
 - a. $\leq +5.0$ mOhms:----- Stable
 - b. $+5.1$ to $+10.0$ mOhms:----- Minor
 - c. $+10.1$ to $+15.0$ mOhms:----- Acceptable
 - d. $+15.1$ to $+50.0$ mOhms:----- Marginal
 - e. $+50.1$ to $+2000$ mOhms ----- Unstable
 - f. $>+2000$ mOhms:----- Open Failure

Date	Feb. 18 2009	Feb. 18 2009	Mar. 10 2009	Mar. 24 2009
Room Temp C	23	22	23	24
RH	31%	28%	40%	24%
Name	Marshall	Lomax	RILEY	RILEY
mOhm values	Actual Initial	Delta 100 Cycles	Delta Thermal	Delta Humidity
Average	0.4	0.1	0.0	0.0
St. Dev.	0.1	0.1	0.0	0.0
Min	0.2	-0.1	-0.1	-0.1
Max	0.5	0.2	0.2	0.2
Count	80	80	80	80

DATA**CONTACT GAPS:**

Initial										
Measured in mm										
Pos.#	B1	B2	B3	B4	B5	B6	B7	B8	B9	B10
1	1.928	1.91	1.896	1.94	1.85	1.91	1.976	1.89	1.924	1.94
2	1.952	1.926	1.898	1.954	1.858	1.932	1.94	1.922	1.948	1.96
3	1.912	1.932	1.898	1.95	1.944	1.85	1.956	1.862	1.94	1.978
4	1.9	1.886	1.902	1.924	1.926	1.822	1.918	1.916	1.918	1.958
5	1.93	1.83	1.904	1.89	1.948	1.912	1.934	1.934	1.898	1.848
6	1.96	1.922	1.86	1.93	1.942	1.968	1.96	1.964	1.94	1.894
7	1.86	1.918	1.926	1.916	1.964	1.95	1.944	1.964	1.87	1.884
8	1.918	1.924	1.928	1.956	1.948	1.874	1.946	1.878	1.892	1.9
After 100 Cycles										
Measured in mm										
Pos.#	B1	B2	B3	B4	B5	B6	B7	B8	B9	B10
1	1.878	1.892	1.866	1.87	1.826	1.88	1.92	1.848	1.89	1.91
2	1.914	1.904	1.878	1.918	1.83	1.9	1.91	1.886	1.908	1.922
3	1.912	1.92	1.864	1.92	1.912	1.83	1.93	1.82	1.906	1.944
4	1.878	1.852	1.87	1.886	1.874	1.834	1.89	1.914	1.894	1.928
5	1.918	1.826	1.862	1.854	1.922	1.884	1.904	1.9	1.866	1.842
6	1.928	1.91	1.846	1.884	1.928	1.928	1.918	1.92	1.91	1.85
7	1.832	1.898	1.906	1.874	1.936	1.95	1.916	1.926	1.844	1.852
8	1.876	1.896	1.908	1.914	1.91	1.842	1.922	1.846	1.86	1.862
After Thermal										
Measured in mm										
Pos.#	B1	B2	B3	B4	B5	B6	B7	B8	B9	B10
1	1.88	1.898	1.892	1.904	1.844	1.9	1.924	1.864	1.898	1.916
2	1.908	1.91	1.882	1.9	1.87	1.934	1.9	1.878	1.904	1.91
3	1.9	1.918	1.88	1.914	1.926	1.84	1.918	1.83	1.9	1.944
4	1.884	1.878	1.88	1.886	1.898	1.834	1.882	1.874	1.892	1.928
5	1.914	1.844	1.92	1.86	1.938	1.89	1.904	1.908	1.864	1.85
6	1.938	1.92	1.858	1.898	1.94	1.95	1.922	1.93	1.876	1.872
7	1.834	1.91	1.92	1.888	1.94	1.918	1.902	1.922	1.832	1.866
8	1.876	1.898	1.914	1.908	1.916	1.872	1.908	1.854	1.836	1.876
After Humidity										
Measured in mm										
Pos.#	B1	B2	B3	B4	B5	B6	B7	B8	B9	B10
1	1.834	1.878	1.89	1.904	1.832	1.898	1.94	1.856	1.94	1.982
2	1.934	1.892	1.87	1.898	1.866	1.924	1.912	1.908	1.924	1.86
3	1.852	1.886	1.872	1.91	1.934	1.83	1.948	1.838	1.89	1.964
4	1.874	1.852	1.87	1.886	1.9	1.836	1.9	1.91	1.918	1.912
5	1.874	1.826	1.91	1.876	1.968	1.904	1.896	1.9	1.854	1.882
6	1.906	1.914	1.85	1.906	1.958	1.928	1.95	1.922	1.884	1.946
7	1.918	1.89	1.94	1.902	1.962	1.922	1.916	1.898	1.832	1.872
8	1.844	1.93	1.898	1.876	1.908	1.878	1.952	1.856	1.83	1.916

MATING/UNMATING:

Sample#	Initial		After 25 Cycles		After 50 Cycles		After 75 Cycles		After 100 Cycles		After Thermals		After Humidity	
	Mating	Unmating	Mating	Unmating	Mating	Unmating	Mating	Unmating	Mating	Unmating	Mating	Unmating	Mating	Unmating
1	8.87	7.26	8.36	6.98	8.44	8.26	9.26	8.67	9.33	8.62	6.30	5.99	6.12	5.90
2	8.04	7.29	7.85	7.50	8.76	8.37	9.14	8.71	9.59	9.11	6.40	6.38	6.36	6.37
3	6.57	5.85	7.79	7.44	8.58	8.04	8.95	8.34	9.39	8.87	6.14	6.29	6.11	6.11
4	8.16	6.14	8.22	7.18	8.53	8.33	9.29	9.04	9.48	9.35	5.87	5.81	6.31	5.51
5	6.49	6.26	8.20	7.58	9.39	8.82	9.80	9.30	10.35	9.81	6.41	6.38	6.51	6.19
6	6.69	6.43	7.39	6.69	7.47	7.45	7.86	8.08	8.50	8.72	6.12	6.02	6.02	6.01
7	9.23	6.47	9.58	7.85	9.91	9.13	9.79	9.80	10.20	10.44	6.51	6.71	6.18	6.35
8	7.09	6.58	8.79	8.76	9.77	9.77	10.35	10.44	10.54	10.72	7.15	7.43	6.24	6.35
9	6.90	6.83	8.61	8.42	10.02	9.95	10.61	10.64	11.09	11.16	6.99	6.85	7.09	7.13
10	7.40	7.00	7.60	7.63	8.69	8.64	9.19	9.15	9.59	9.56	6.96	6.98	6.40	6.37

NORMAL FORCE (FOR CONTACTS TESTED IN THE HOUSING), Initial:

Initial Deflections in inches, Forces in Grams

Sample #	0.0013	0.0026	0.0039	0.0052	0.0065	0.0078	0.0091	0.0104	0.0117	0.0130	SET
1	87.8	170.4	249.2	322.9	396.3	468.7	543.6	622.3	700.4	767.1	0.0002
2	86.9	169.9	243.1	308.8	368.7	424.8	479.4	534.0	594.7	653.7	0.0021
3	80.9	162.7	241.6	316.7	391.0	461.6	533.7	603.5	673.4	742.5	0.0002
4	91.0	181.2	267.6	348.7	425.4	498.7	569.1	639.5	705.1	767.5	0.0002
5	83.6	164.6	242.5	321.8	401.1	482.5	561.5	641.5	722.6	798.8	0.0002
6	87.3	171.7	252.3	332.1	408.7	481.6	552.8	622.8	692.5	760.7	0.0003
7	68.8	141.2	211.5	278.9	343.1	406.1	467.7	524.9	575.5	628.5	0.0009
8	66.0	144.4	220.7	294.5	373.7	455.6	534.8	614.9	693.8	768.2	0.0003
9	111.1	203.3	300.3	390.4	474.0	553.0	620.3	686.8	745.5	792.4	0.0021
10	83.3	171.7	267.2	363.5	455.9	544.3	630.8	718.3	802.8	858.2	0.0006
11	86.1	169.4	253.6	336.1	419.6	516.8	611.4	700.3	789.4	852.2	0.0004
12	75.0	153.7	229.7	303.0	373.2	441.4	506.5	577.1	654.8	734.6	0.0005

NORMAL FORCE (FOR CONTACTS TESTED IN THE HOUSING), After Thermals:

After Thermals Deflections in inches, Forces in Grams

Sample #	0.0013	0.0026	0.0039	0.0052	0.0065	0.0078	0.0091	0.0104	0.0117	0.0130	SET
1	81.4	159.1	235.4	311.3	384.4	459.8	533.3	606.8	680.1	756.5	0.0002
2	82.6	166.5	248.2	332.1	418.0	501.4	583.6	669.7	757.9	837.3	0.0004
3	97.6	194.9	295.1	403.6	510.3	618.9	726.5	835.9	940.2	996.4	0.0008
4	109.8	216.9	318.7	428.3	529.6	628.2	718.7	789.2	846.7	890.9	0.0009
5	75.1	150.4	219.9	293.1	368.1	441.3	514.0	586.2	659.8	731.4	0.0003
6	90.5	178.2	263.3	345.0	421.4	498.0	571.2	645.9	727.8	798.1	0.0002
7	94.7	186.1	275.3	358.1	439.3	517.4	593.4	668.1	750.6	828.3	0.0001
8	73.2	160.3	245.2	329.3	417.9	505.6	591.3	674.5	756.2	830.3	0.0002
9	62.6	125.2	187.8	248.8	308.8	367.4	425.5	484.1	539.8	596.4	0.0003
10	82.3	161.6	235.7	305.6	375.4	443.1	505.9	568.7	629.4	689.3	0.0002
11	84.5	167.8	248.6	325.7	396.0	459.3	522.7	583.6	643.8	704.2	0.0002
12	72.3	152.1	227.8	301.1	371.3	436.7	497.4	556.5	613.7	671.2	0.0004

INSULATION RESISTANCE (IR):

Initial Insulation Resistance		
Measured In Meg Ohms		

Pin to Pin			
Mated		Unmated	
X		X	
Sample#	MPS/MPT	MPS	MPT
1	100,000	100,000	100,000
2	100,000	100,000	100,000

Thermal Insulation Resistance		
Measured In Meg Ohms		

Pin to Pin			
Mated		Unmated	
X		X	
Sample#	MPS/MPT	MPS	MPT
1	100000	100000	100000
2	100000	100000	100000

Humidity Insulation Resistance		
Measured In Meg Ohms		

Pin to Pin			
Mated		Unmated	
X		X	
Sample#	MPS/MPT	MPS	MPT
1	100,000	100,000	100,000
2	12,000	100,000	12,000

DIELECTRIC WITHSTANDING VOLTAGE (DWV):

Initial DWV	
Test Voltage= 1800	

Pin to Pin			
Mated		Unmated	
Sample#	MPS/MPT	MPS	MPT
1	1800	1800	1800
2	1800	1800	1800

Thermal Test Voltage	
Test Voltage= 1800	

Pin to Pin			
Mated		Unmated	
Sample#	MPS/MPT	MPS	MPT
1	1800	1800	1800
2	1800	1800	1800

Humidity Test Voltage	
Test Voltage= 1800	

Pin to Pin			
Mated		Unmated	
Sample#	MPS/MPT	MPS	MPT
1	1800	1800	1800
2	1800	1800	1800

LLCR:

	mOhm values	Actual	Delta	Delta	Delta
Board	Position	Initial	100 Cycles	Thermal	Humidity
1	P1	0.4	0.1	0.0	0.1
1	P2	0.4	0.1	0.0	0.0
1	P3	0.4	0.0	0.0	0.1
1	P4	0.3	0.1	0.1	0.1
1	P5	0.3	0.1	0.1	0.1
1	P6	0.3	0.1	0.1	0.1
1	P7	0.3	0.1	0.1	0.0
1	P8	0.3	0.1	0.1	0.1
2	P1	0.4	0.1	0.0	0.0
2	P2	0.4	0.0	0.0	-0.1
2	P3	0.4	0.0	0.0	-0.1
2	P4	0.3	0.0	0.1	0.0
2	P5	0.4	0.0	0.0	-0.1
2	P6	0.3	0.1	0.0	0.1
2	P7	0.3	0.0	0.0	0.0
2	P8	0.3	0.1	0.1	0.1
3	P1	0.4	0.1	0.0	0.0
3	P2	0.4	0.1	0.0	0.0
3	P3	0.4	0.1	0.0	0.0
3	P4	0.3	0.1	0.0	0.0
3	P5	0.3	0.1	0.1	0.0
3	P6	0.3	0.1	0.1	0.0
3	P7	0.3	0.1	0.0	0.0
3	P8	0.3	0.1	0.0	0.1
4	P1	0.4	0.1	0.0	0.0
4	P2	0.4	0.1	0.0	0.0
4	P3	0.4	0.1	0.0	0.0
4	P4	0.3	0.1	0.1	0.0
4	P5	0.4	0.1	0.1	0.0
4	P6	0.4	0.0	0.0	0.0
4	P7	0.3	0.1	0.0	0.1
4	P8	0.4	0.1	0.1	0.1
5	P1	0.4	0.0	0.0	0.0
5	P2	0.4	0.0	0.0	0.0
5	P3	0.4	0.0	0.0	0.0
5	P4	0.3	0.0	0.0	0.0
5	P5	0.3	0.1	0.0	0.0
5	P6	0.3	0.1	0.1	0.1
5	P7	0.3	0.1	0.0	0.0
5	P8	0.3	0.1	0.0	0.0
6	P1	0.4	0.1	0.1	0.1

Part description: Mini Power Strip

6	P2	0.4	0.1	0.1	0.1
6	P3	0.5	0.0	-0.1	-0.1
6	P4	0.4	0.1	0.1	0.0
6	P5	0.5	0.0	-0.1	-0.1
6	P6	0.3	0.1	0.1	0.1
6	P7	0.3	0.1	0.1	0.1
6	P8	0.2	0.2	0.2	0.2
7	P1	0.3	0.2	0.1	0.1
7	P2	0.3	0.2	0.1	0.0
7	P3	0.3	0.1	0.1	0.1
7	P4	0.4	0.1	0.0	0.0
7	P5	0.3	0.2	0.1	0.1
7	P6	0.3	0.2	0.1	0.1
7	P7	0.3	0.2	0.1	0.1
7	P8	0.3	0.2	0.1	0.1
8	P1	0.5	0.0	0.0	0.0
8	P2	0.4	0.1	0.0	0.0
8	P3	0.4	0.1	0.0	0.0
8	P4	0.4	0.0	0.0	0.0
8	P5	0.4	0.0	0.0	0.0
8	P6	0.4	0.0	0.0	0.0
8	P7	0.4	0.0	0.0	0.0
8	P8	0.4	0.0	0.0	0.0
9	P1	0.4	0.0	0.1	0.0
9	P2	0.4	0.0	0.0	-0.1
9	P3	0.4	0.0	0.0	-0.1
9	P4	0.4	0.0	0.0	0.0
9	P5	0.4	0.0	0.1	0.0
9	P6	0.3	0.1	0.1	0.0
9	P7	0.3	0.1	0.0	0.1
9	P8	0.3	0.1	0.0	0.0
10	P1	0.4	0.0	0.0	0.0
10	P2	0.4	0.1	0.0	0.0
10	P3	0.4	0.0	0.0	0.0
10	P4	0.3	0.0	0.0	0.0
10	P5	0.3	0.0	0.0	0.0
10	P6	0.3	0.0	0.0	0.0
10	P7	0.3	0.0	0.0	0.0
10	P8	0.4	-0.1	0.0	0.0

EQUIPMENT AND CALIBRATION SCHEDULES**Equipment #:** PS-07**Description:** 20 V, 120 A DC Power Supply - AutoRanging SO/HPIB**Manufacturer:** Hewlett Packard / Agilent**Model:** AT-6031A**Serial #:** 2721A00648**Accuracy:** See Manual Current Carrying Capacity (CCC) Chamber

... Last Cal: 06/16/2008, Next Cal: 06/16/2009

Equipment #: MO-04**Description:** Multimeter /Data Acquisition System**Manufacturer:** Keithley**Model:** 2700**Serial #:** 0798688**Accuracy:** See Manual - DO NOT USE UNTIL CALIBRATED.

... Last Cal: 03/10/08, Next Cal: 03/10/09

Equipment #: MO-06**Description:** Micro-Ohmmeter**Manufacturer:** Keithley**Model:** 580**Serial #:** 1110525**Accuracy:** See Manual

... Last Cal: 06/17/2008, Next Cal: 06/17/2009

Equipment #: MO-07**Description:** Multimeter / Data Acquisition System**Manufacturer:** Keithley**Model:** 2700**Serial #:** 1116559**Accuracy:** See Manual

... Last Cal: 6/17/2008, Next Cal: 6/17/2009

Equipment #: MO-01**Description:** Micro-Ohmmeter**Manufacturer:** Keithley**Model:** 580**Serial #:** 0772740**Accuracy:** See Manual

... Last Cal: 06/17/08, Next Cal: 06/17/09

Equipment #: MO-03**Description:** Multimeter /Data Acquisition System**Manufacturer:** Keithley**Model:** 2700**Serial #:** 0791975**Accuracy:** See Manual

... Last Cal: 06/17/08, Next Cal: 06/17/09

Equipment #: MV-05**Description:** 6" x 6" Video Measuring Machine**Manufacturer:** Micro-Vu**Model:** M3010838**Serial #:** V9344**Accuracy:** See Manual See Manual

... Last Cal: 02/10/2009, Next Cal: 02/10/2010

Equipment #: OV-03**Description:** Cascade Tek Forced Air Oven**Manufacturer:** Cascade Tek**Model:** TFO-5**Serial #:** 0500100**Accuracy:** Temp. Stability: +/- .1C/C change in ambient

... Last Cal: 06/17/2009, Next Cal: 06/17/2010

Equipment #: TCT-01**Description:** Test Stand**Manufacturer:** Chatillon**Model:** TCD-1000**Serial #:** 05 23 00 02**Accuracy:** Speed Accuracy: +/-5% of max speed; Displacement: +/- .5% or +/- .005, whichever is greater.

... Last Cal: 8/12/08, Next Cal: 8/12/09

Equipment #: TCT-03**Description:** Dillon Quantrol TC2 Test Stand**Manufacturer:** Dillon Quantrol**Model:** TC2**Serial #:** 02-1033-03**Accuracy:** Speed Accuracy: +/- 5% of indicated speed; Displacement: +/- 5 micrometers.

... Last Cal: 5/6/2008, Next Cal: 5/6/2009

Equipment #: TCT-04**Description:** Dillon Quantrol TC21 25-1000 mm/min series test stand**Manufacturer:** Dillon Quantrol**Model:** TC2 I series test stand**Serial #:** 2721A00648**Accuracy:** Speed Accuracy: +/- 5% of indicated speed; Speed Accuracy: +/- 5% of indicated speed;

... Last Cal: 5/6/2008, Next Cal: 5/6/2009

Equipment #: HPM-01**Description:** Hipot Megommeter**Manufacturer:** Hipotronics**Model:** H306B-A**Serial #:** M9905004**Accuracy:** 2 % Full Scale Accuracy

... Last Cal: 06/22/07, Next Cal: 06/22/08

Equipment #: THC-04

Description: Temperature/Humidity Chamber

Manufacturer: Thermotron

Model: SM-8-3800

Serial #: 37782

Accuracy: See Manual

... Last Cal: 04/07/2009, Next Cal: 04/07/2010